



US00D733688S

(12) **United States Design Patent**
Han

(10) **Patent No.:** **US D733,688 S**
(45) **Date of Patent:** **** Jul. 7, 2015**

(54) **SPEAKER BOX**

(71) Applicant: **Sony Corporation**, Tokyo (JP)

(72) Inventor: **Jia Han**, Shanghai (CN)

(73) Assignee: **Sony Corporation**, Tokyo (JP)

(**) Term: **14 Years**

(21) Appl. No.: **29/445,366**

(22) Filed: **Feb. 11, 2013**

(30) **Foreign Application Priority Data**

Aug. 17, 2012 (CN) 2012 3 0391165

(51) **LOC (10) Cl.** **14-03**

(52) **U.S. Cl.**

USPC **D14/219; D14/210**

(58) **Field of Classification Search**

USPC D14/167, 168, 170-172, 188, 194-196,
D14/204, 207, 209.1, 210-216, 219, 221,
D14/222, 224, 496; 181/143, 144, 147, 148,
181/150, 153, 157, 198, 199; 381/300-303,
381/306, 332, 333, 336, 345, 361-364,
381/386-388; 369/6-12

CPC B60R 11/0217; G06F 1/1688; H04M 1/03;
H04M 1/035; H04R 1/02; H04R 1/06; H04R
1/021; H04R 1/025; H04R 1/026; H04R
1/028; H04R 1/105; H04R 1/323; H04R
1/403; H04R 1/2803; H04R 1/2834; H04R
5/02; H04R 7/20; H04R 9/06; H04R 9/025;
H04R 2201/021; H04R 2400/00; H04R
2400/07; H04R 2499/11; H04R 2499/13;
H04R 2499/15; H04S 3/00; H04S 7/30

See application file for complete search history.

(56) **References Cited**

U.S. PATENT DOCUMENTS

D382,563 S	8/1997	Shiono	
D402,658 S	12/1998	Hyogo	
D410,925 S *	6/1999	Kawase et al.	D14/168
D412,505 S	8/1999	Matsuoka	
D464,641 S *	10/2002	Liu	D14/214
D465,210 S *	11/2002	Liu	D14/214
D514,090 S *	1/2006	Carbone et al.	D14/209.1
D516,538 S	3/2006	Hibi	
D524,287 S *	7/2006	Hibi	D14/168
D556,737 S *	12/2007	Oh	D14/214
D570,829 S	6/2008	Matsuoka	
D570,869 S *	6/2008	Yamada	D14/496
D572,237 S *	7/2008	Hsiung	D14/214
D581,392 S *	11/2008	Zheng	D14/168
D603,368 S *	11/2009	Jang	D14/194
D629,013 S *	12/2010	Song et al.	D14/500
D641,730 S	7/2011	Oota	
D673,525 S	1/2013	Goetzen et al.	

(Continued)

FOREIGN PATENT DOCUMENTS

JP D1426449 S 11/2011

Primary Examiner — Keli L Hill

(74) *Attorney, Agent, or Firm* — Fishman Stewart Yamaguchi PLLC

(57) **CLAIM**

The ornamental design for a speaker box, as shown and described.

DESCRIPTION

FIG. 1 is a perspective view of a speaker box showing my new design;
FIG. 2 is a front elevational view thereof;
FIG. 3 is a left side elevational view thereof;
FIG. 4 is a right side elevational view thereof;
FIG. 5 is a top plan view thereof; and,
FIG. 6 is a bottom plan view thereof.
The broken lines shown are included for the purpose of illustrating portions of the speaker box that form no part of the claim.

1 Claim, 5 Drawing Sheets

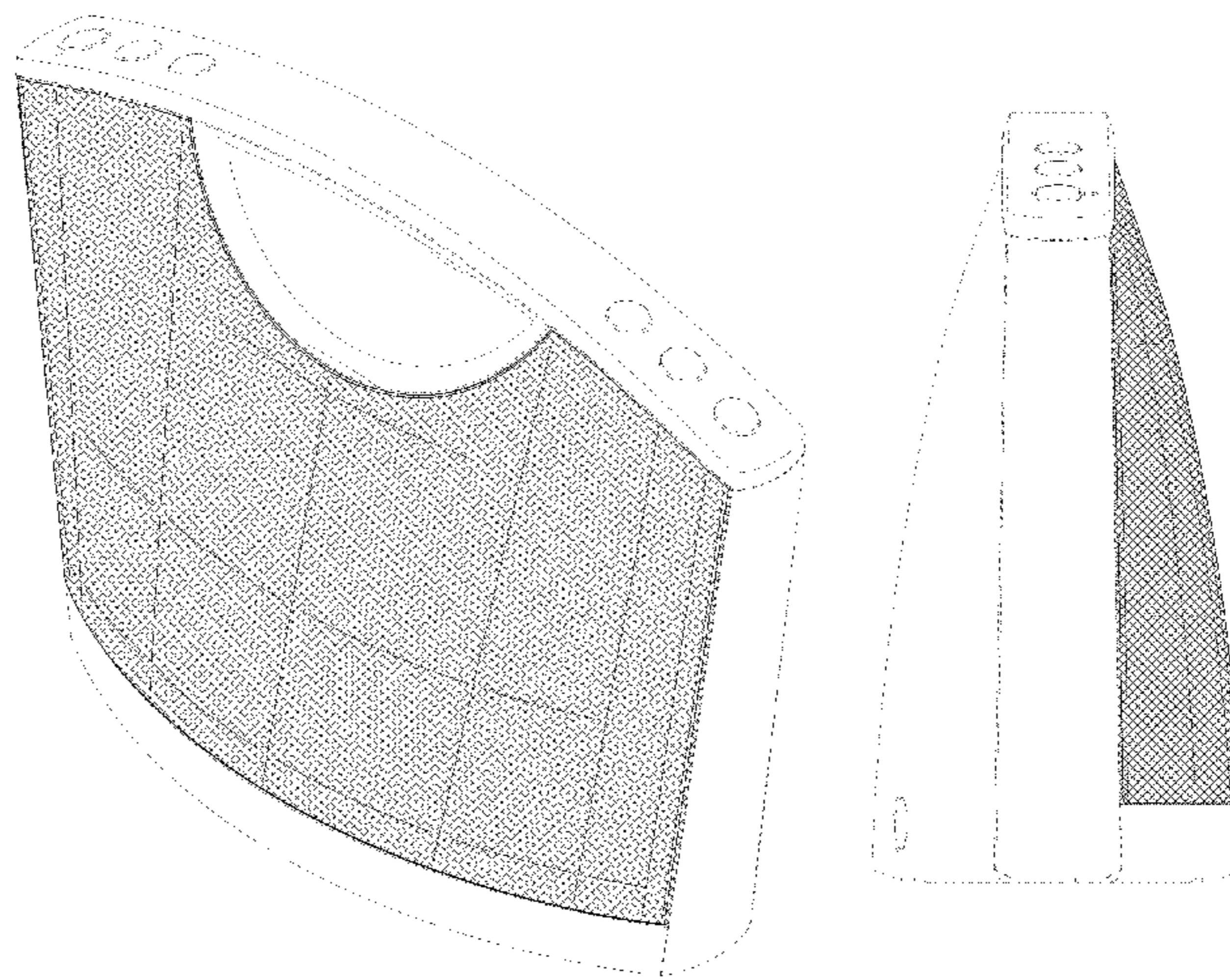

(56)

References Cited

D695,705 S * 12/2013 Shimizu et al. D14/172
D710,819 S * 8/2014 Poandl D14/171

U.S. PATENT DOCUMENTS

D675,596 S 2/2013 Kusuki et al.

* cited by examiner

FIG.1

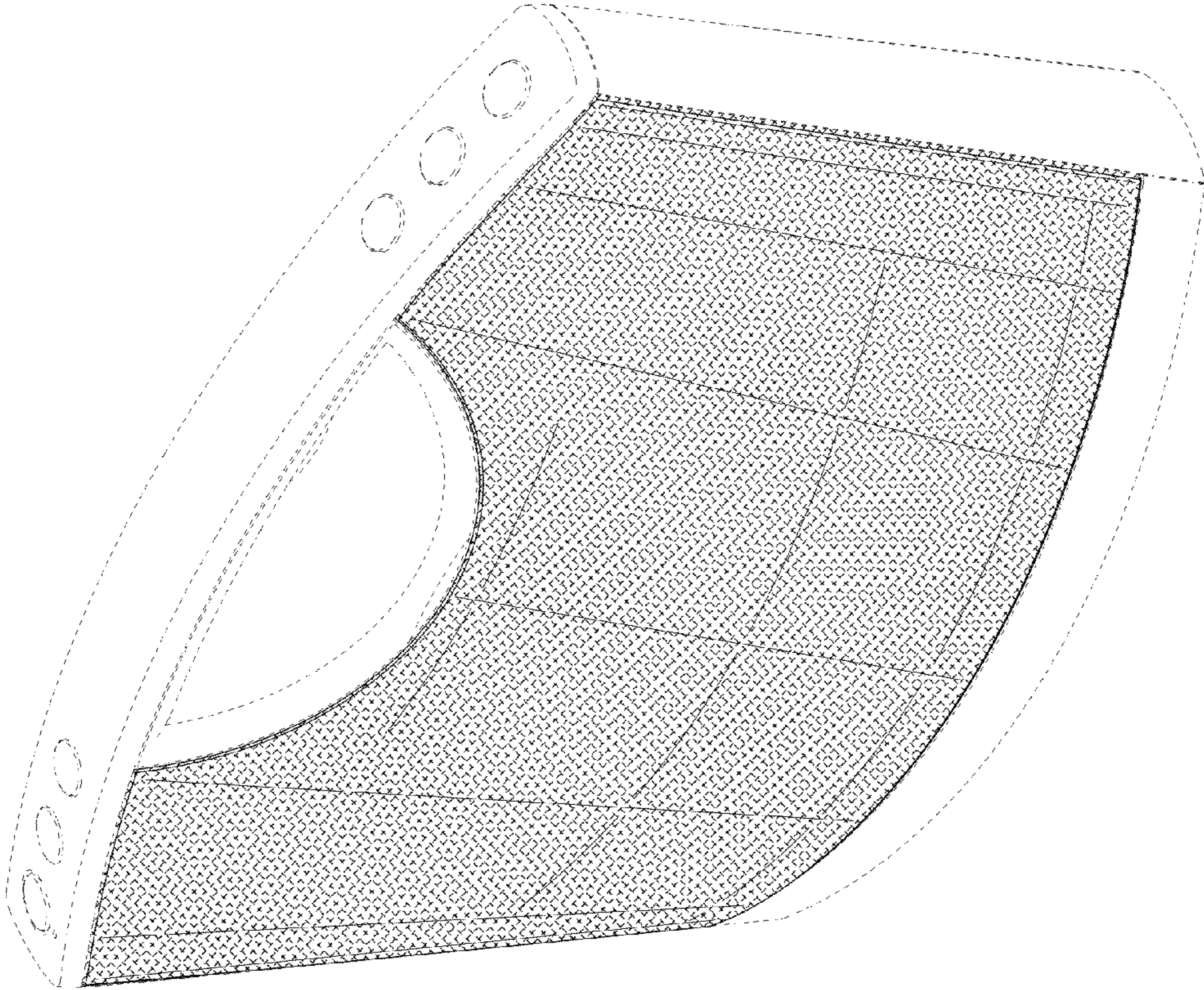
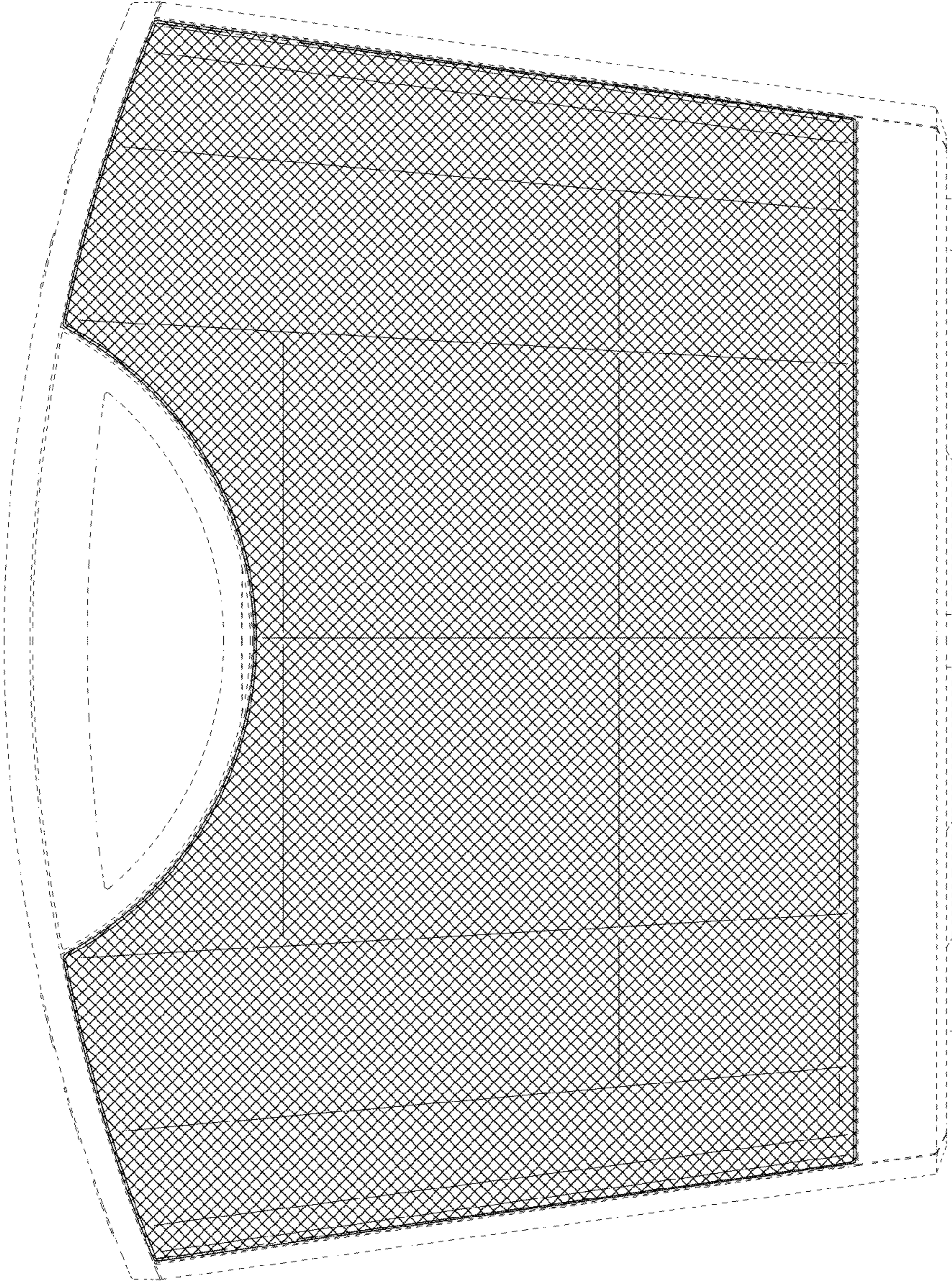

FIG.2



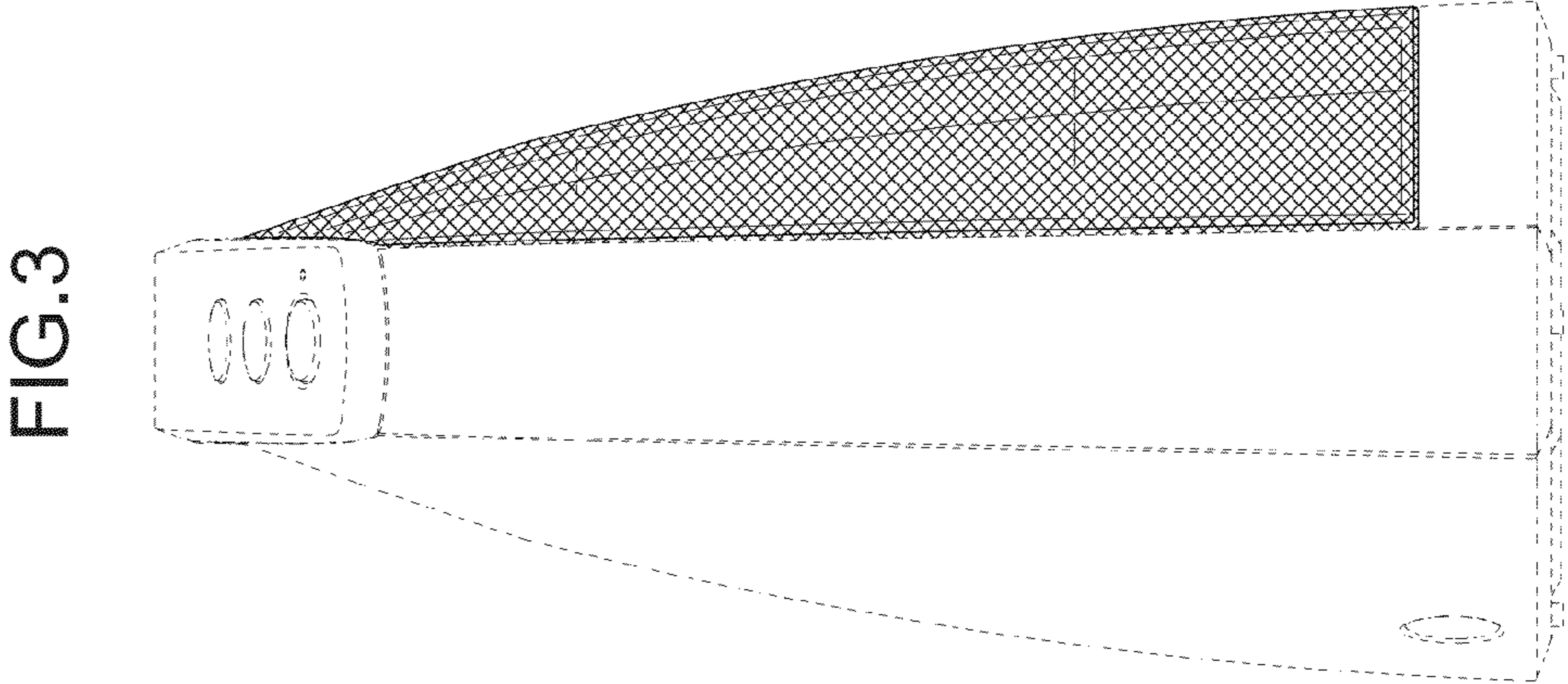
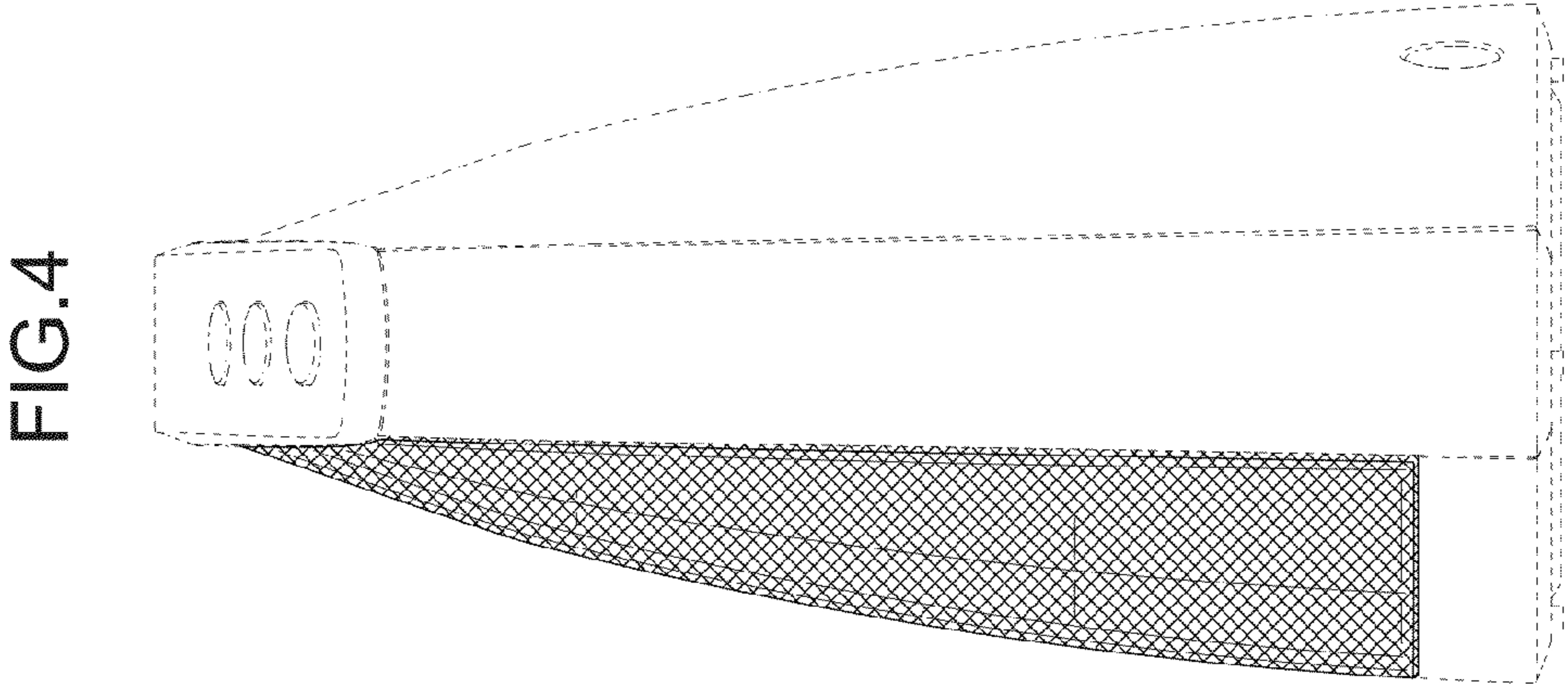

FIG.5

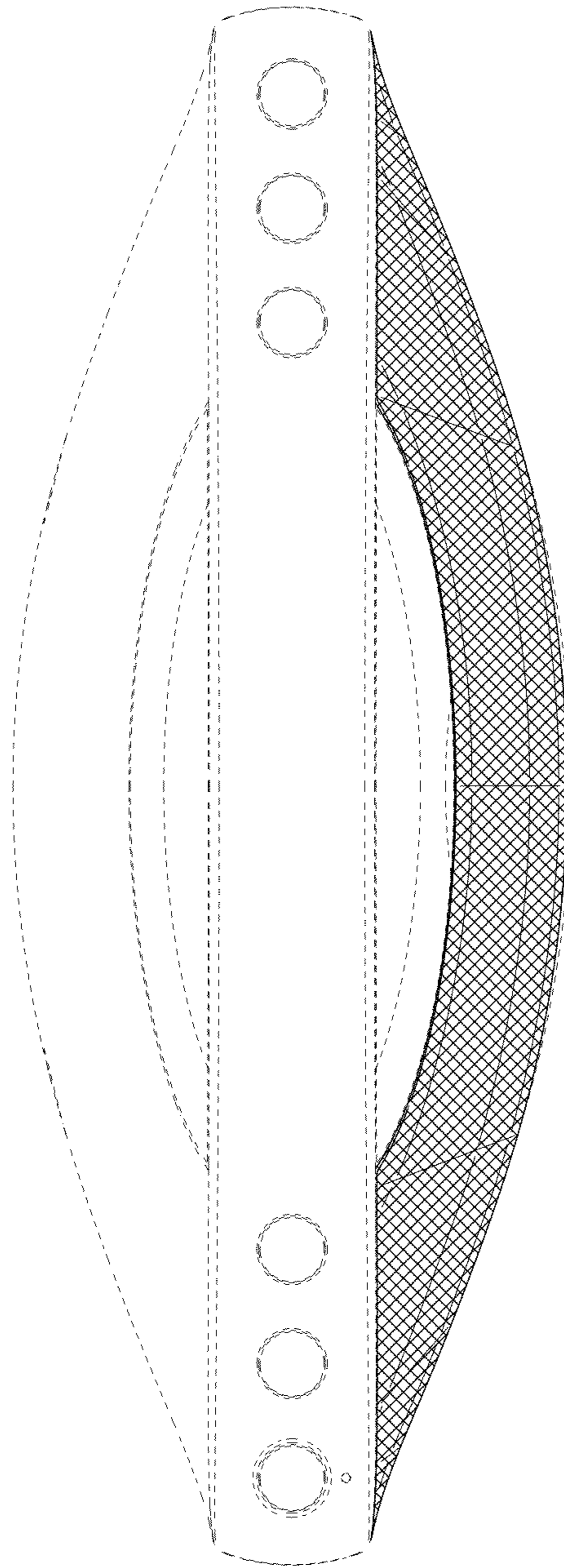

FIG.6

