



US00D733307S

(12) **United States Design Patent**
Suzuki

(10) **Patent No.:** **US D733,307 S**
(45) **Date of Patent:** **** Jun. 30, 2015**

(54) **CONDUCTIVE PAD SET OF A BIOMEDICAL SIGNAL RECORDER WITH A RADIO FUNCTION**

(71) Applicant: **Kabushiki Kaisha Toshiba**, Minato-ku, Tokyo (JP)

(72) Inventor: **Takuji Suzuki**, Yokohama (JP)

(73) Assignee: **Kabushiki Kaisha Toshiba**, Tokyo (JP)

(**) Term: **14 Years**

(21) Appl. No.: **29/465,704**

(22) Filed: **Aug. 30, 2013**

(30) **Foreign Application Priority Data**

Mar. 4, 2013 (JP) 2013-004674

(51) **LOC (10) Cl.** **24-01**

(52) **U.S. Cl.**
USPC **D24/187**

(58) **Field of Classification Search**
USPC D24/168, 186-187, 200, 232, 189, 192;
D10/46; 600/372-384, 391-393;
607/62, 109, 121, 139

See application file for complete search history.

(56) **References Cited**

U.S. PATENT DOCUMENTS

D255,149 S *	5/1980	Bevilacqua	D24/187
D321,761 S *	11/1991	Shimizu	D24/168
D409,752 S *	5/1999	Bishay et al.	D24/187
D448,850 S *	10/2001	Fabricant	D24/189
D456,907 S *	5/2002	Sanfilippo	D24/187
D468,433 S *	1/2003	Wagner et al.	D24/187

D471,281 S *	3/2003	Baura et al.	D24/187
D475,138 S *	5/2003	Baura et al.	D24/187
D495,055 S *	8/2004	Silber	D24/187
D567,949 S *	4/2008	Lash et al.	D24/168
D568,479 S *	5/2008	Mao et al.	D24/168
D584,414 S *	1/2009	Lash et al.	D24/187
D587,375 S *	2/2009	Mao et al.	D24/168
D598,114 S *	8/2009	Cryan	D24/187
D598,557 S *	8/2009	Powaser	D24/192

* cited by examiner

Primary Examiner — T. Chase Nelson

Assistant Examiner — Mark Cavanna

(74) *Attorney, Agent, or Firm* — Banner & Witcoff, Ltd.

(57) **CLAIM**

The ornamental design for a conductive pad set of a biomedical signal recorder with a radio function, as shown and described.

DESCRIPTION

FIG. 1 is a perspective view of a conductive pad set of a biomedical signal recorder with a radio function, showing my new design;

FIG. 2 is a top view thereof;

FIG. 3 is a bottom view thereof;

FIG. 4 is a front view thereof;

FIG. 5 is a right side view thereof; the left side being symmetrical;

FIG. 6 is a rear view thereof; and,

FIG. 7 is an end view thereof, taken along the line 7-7 in FIG. 4.

The broken lines are included for the purpose of illustrating portions of the conductive pad set of a biomedical signal recorder with a radio function that form no part of the claimed design.

1 Claim, 3 Drawing Sheets

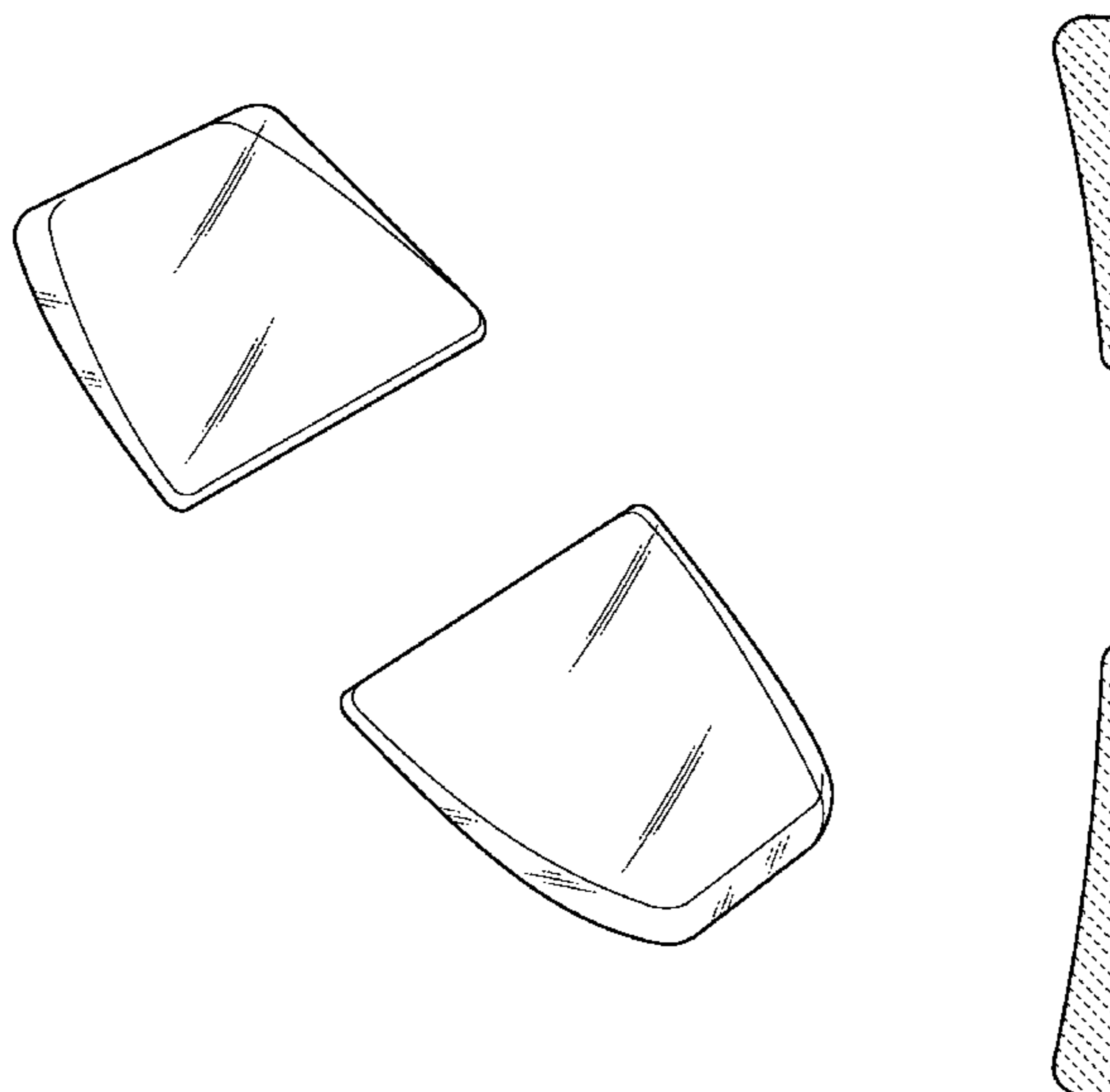

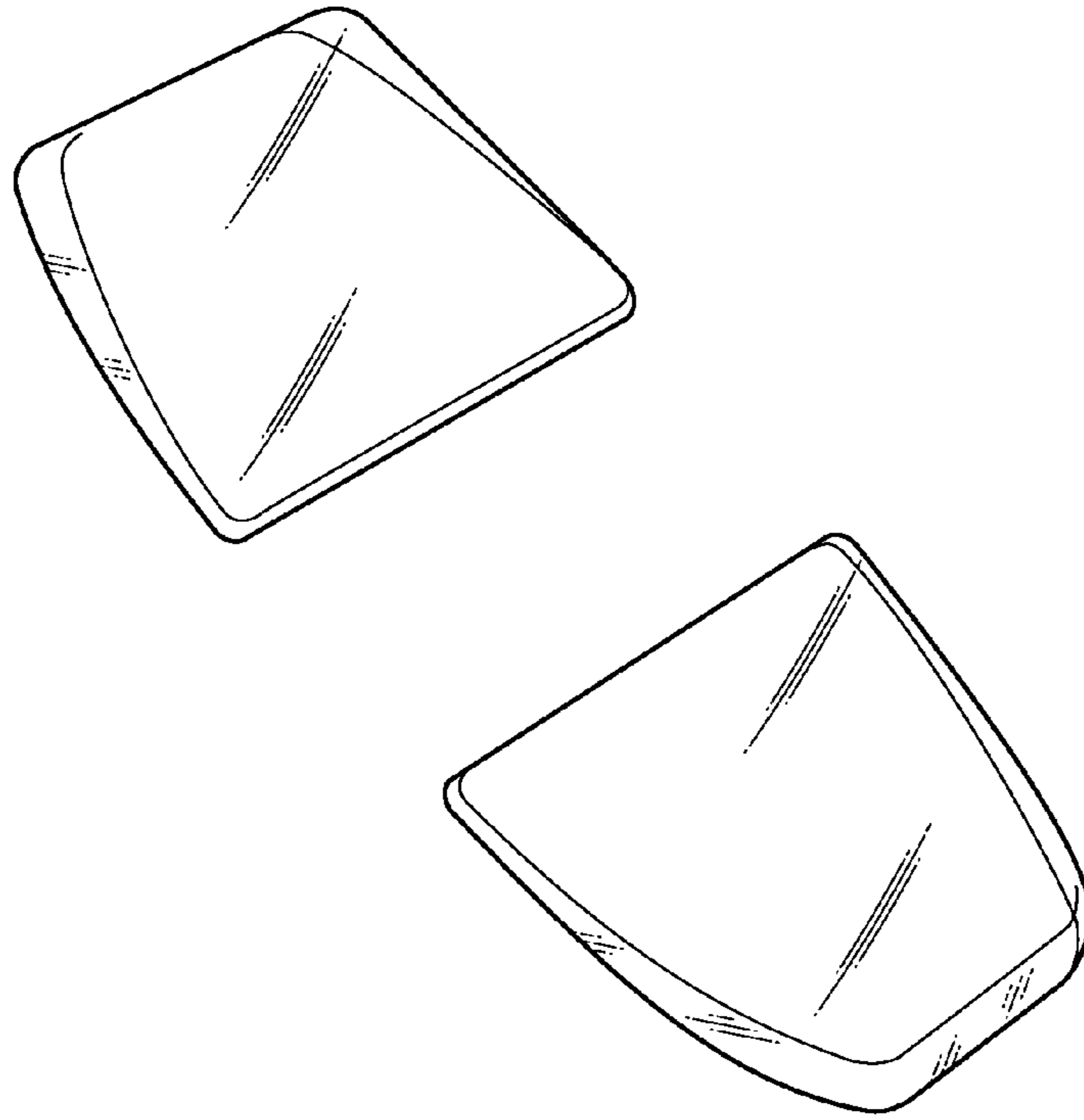

FIG. 1



FIG. 2



FIG. 3

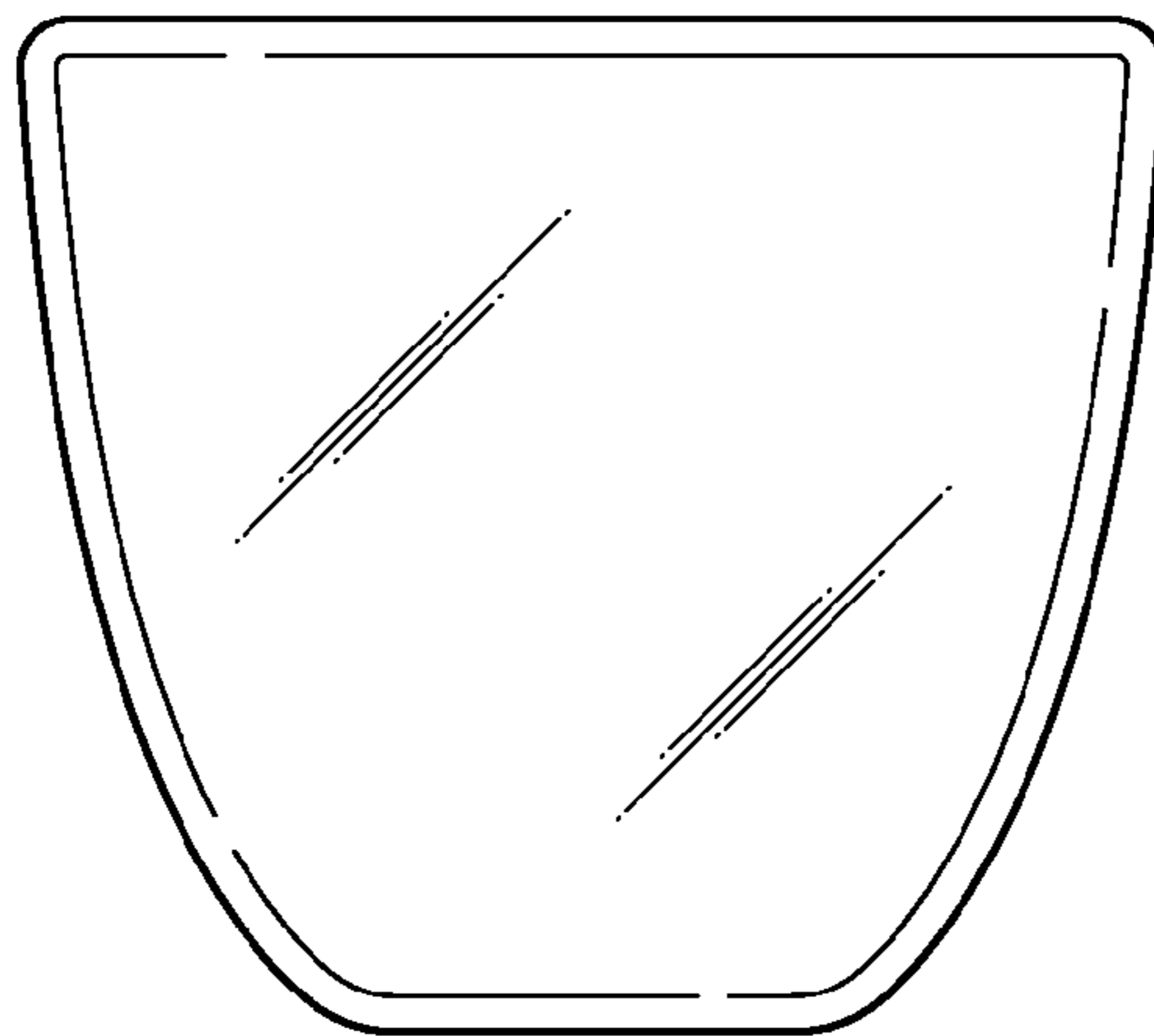
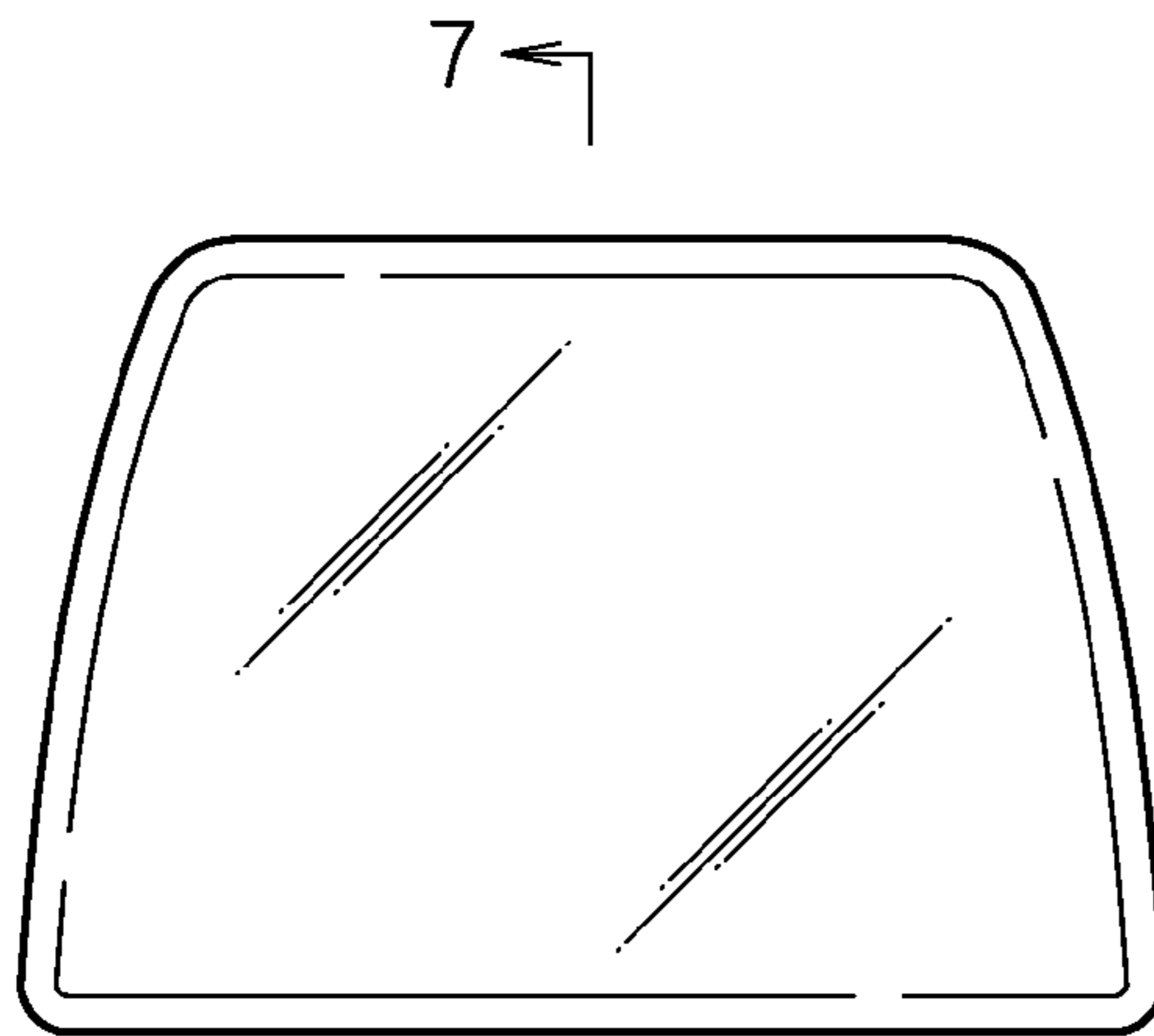

FIG. 4

FIG. 5

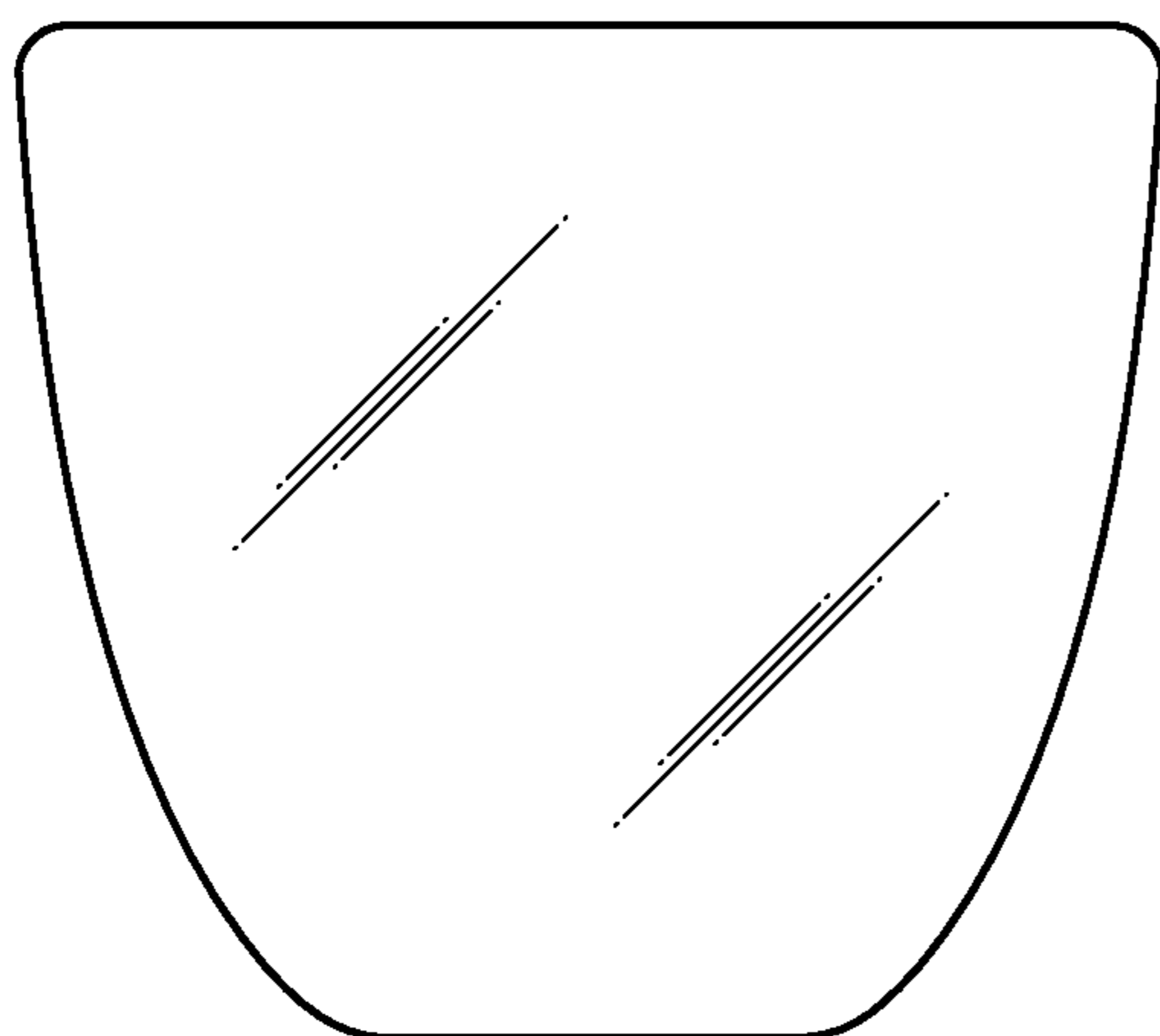
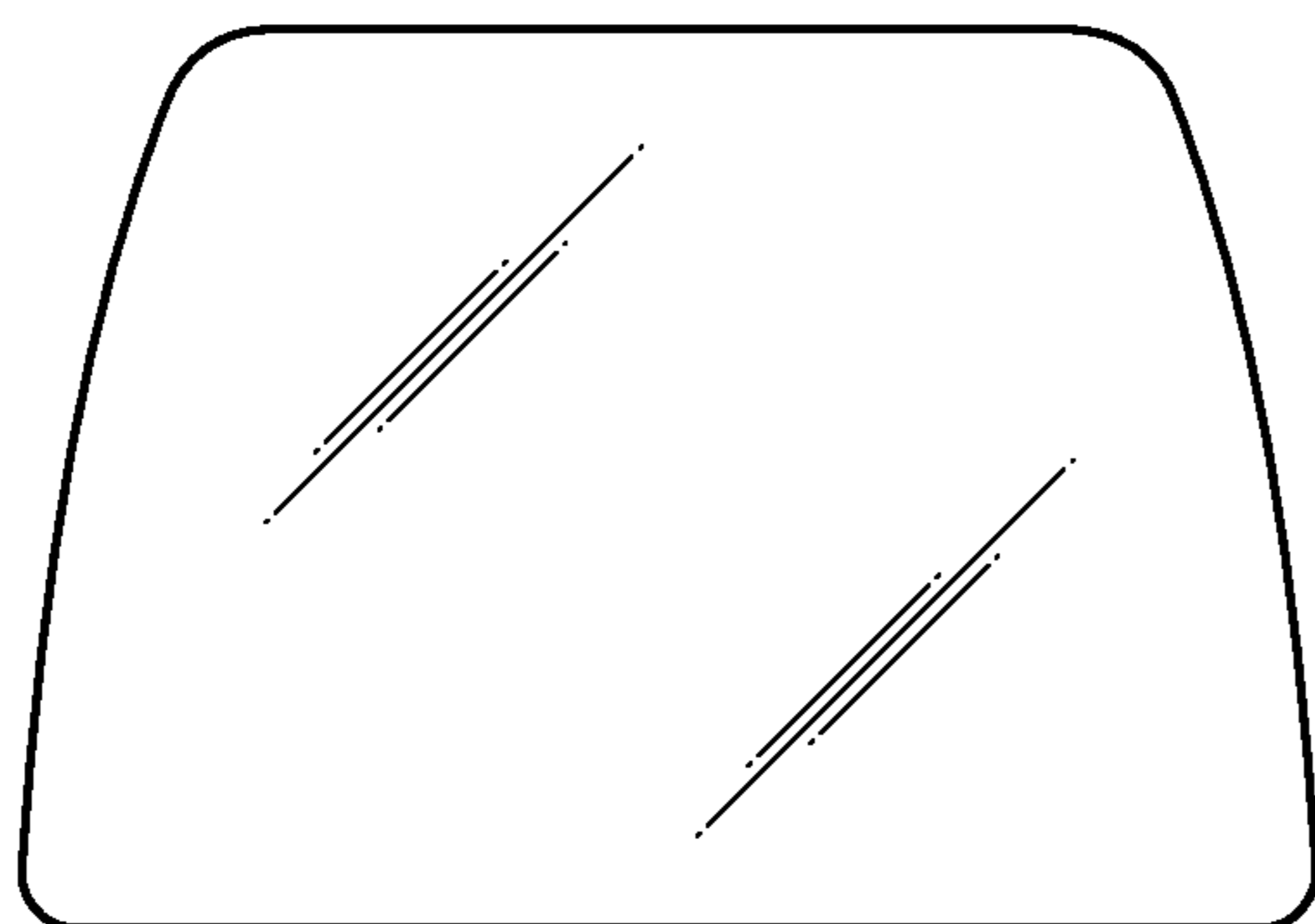

FIG. 6

FIG. 7