



US00D733191S

(12) **United States Design Patent**  
**Whitmer et al.**

(10) **Patent No.:** **US D733,191 S**  
(45) **Date of Patent:** **\*\* Jun. 30, 2015**

- (54) **POST DRIVER CHUCK TUBE**
- (71) Applicant: **Rhino Tool Company**, Kewanee, IL  
(US)
- (72) Inventors: **Herbert W. Whitmer**, Kewanee, IL  
(US); **Robert J. Conner**, Kewanee, IL  
(US); **James V. Martin**, Kewanee, IL  
(US)
- (73) Assignee: **Rhino Tool Company**, Kewanee, IL  
(US)
- (\*\*) Term: **14 Years**
- (21) Appl. No.: **29/481,512**
- (22) Filed: **Feb. 6, 2014**
- (51) **LOC (10) Cl.** ..... **15-03**
- (52) **U.S. Cl.**  
USPC ..... **D15/21**
- (58) **Field of Classification Search**  
USPC ..... D15/17, 21, 28, 140, 139; 173/133, 1,  
173/46, 156, 194, 90, 114, 27; 52/157  
CPC ..... E04H 17/263; E04H 17/26; E02H 17/263;  
E02H 17/26; E02D 11/00; E02D 7/04  
See application file for complete search history.

5,392,866	A *	2/1995	White	.....	173/90
5,806,608	A *	9/1998	DuBois	.....	173/90
6,591,919	B1 *	7/2003	Herrmann	.....	173/42
D634,605	S *	3/2011	Guimaraes	.....	D8/343
2004/0154812	A1 *	8/2004	McDonald	.....	173/90
2006/0241647	A1 *	10/2006	Chen	.....	606/100
2008/0105859	A1 *	5/2008	Laportella	.....	254/29 R
2008/0142235	A1 *	6/2008	Jacobsson	.....	173/27
2009/0008113	A1 *	1/2009	Lyons et al.	.....	173/48
2009/0178818	A1 *	7/2009	McNeill	.....	173/90
2010/0236803	A1 *	9/2010	Clemons	.....	173/128
2011/0155403	A1 *	6/2011	Rohrer	.....	173/114
2011/0204198	A1 *	8/2011	Leary et al.	.....	248/346.03
2012/0111593	A1 *	5/2012	O'Toole	.....	173/90
2012/0193111	A1 *	8/2012	Lechtenberg et al.	.....	173/1
2013/0026721	A1 *	1/2013	Wood	.....	279/145
2014/0020310	A1 *	1/2014	Lee	.....	52/157
2014/0262399	A1 *	9/2014	Cunningham	.....	173/133
2015/0021529	A1 *	1/2015	Gregory et al.	.....	254/30

\* cited by examiner

*Primary Examiner* — Cynthia Ramirez

(74) *Attorney, Agent, or Firm* — Thompson Coburn LLP

(57) **CLAIM**

The ornamental design for a post driver chuck tube, as shown and described.

**DESCRIPTION**

FIG. 1 is a perspective view of the design for a post driver chuck tube.

FIG. 2 shows another perspective view of the design.

FIG. 3 is a front view of the design, with the rear and side views being the same.

FIG. 4 is a top view of the design; and,

FIG. 5 is a bottom view of the design.

The dashed lines in the drawing figures represent the environment and do not constitute part of the claimed design.

**1 Claim, 2 Drawing Sheets**

(56) **References Cited**

U.S. PATENT DOCUMENTS

2,061,218	A *	11/1936	Watson	.....	173/25
2,940,267	A *	6/1960	Shaver	.....	173/46
2,998,087	A *	8/1961	Iddings	.....	173/102
3,215,209	A *	11/1965	Desvaux et al.	.....	173/49
3,762,827	A *	10/1973	Ziegelmeyer	.....	408/14
3,847,231	A *	11/1974	Warjone et al.	.....	173/206
4,311,416	A *	1/1982	Rusche	.....	405/232
4,746,096	A *	5/1988	Donnell et al.	.....	254/29 R

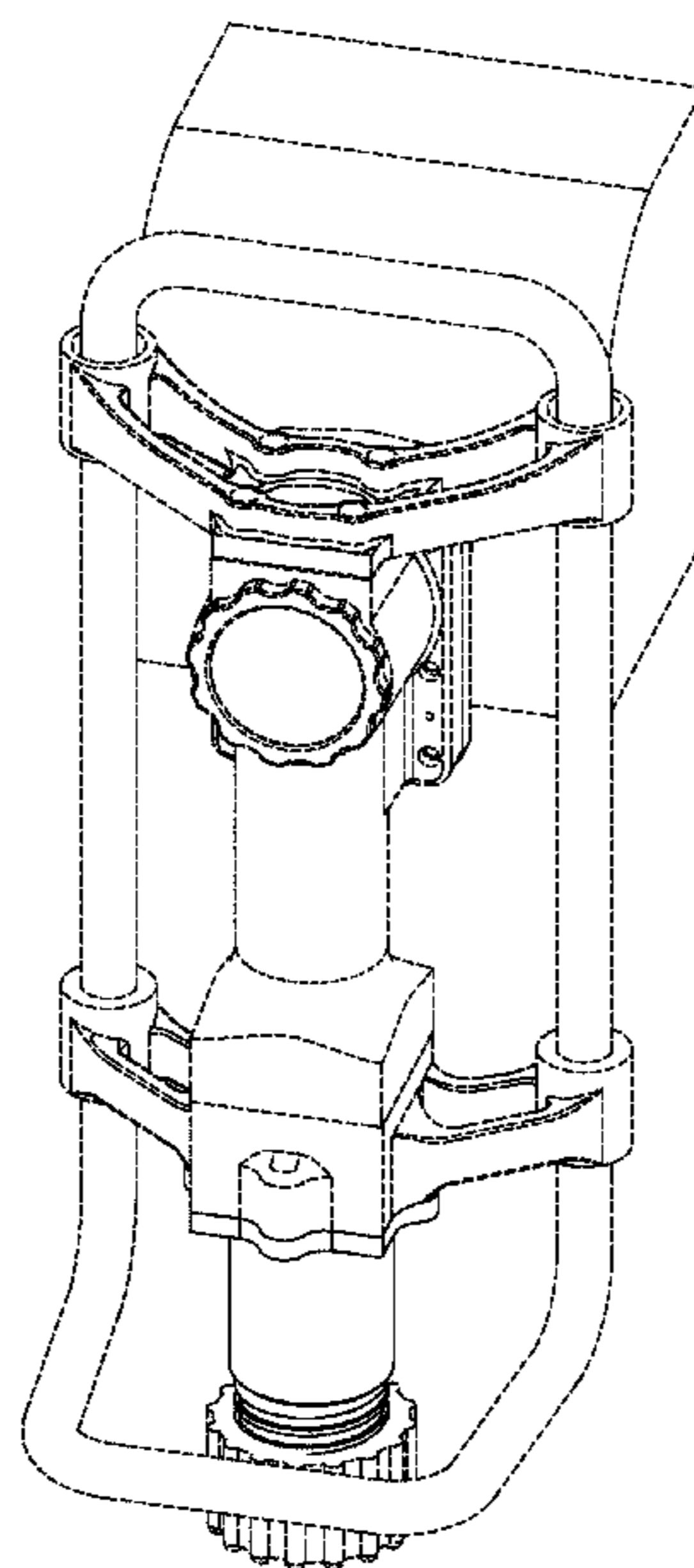

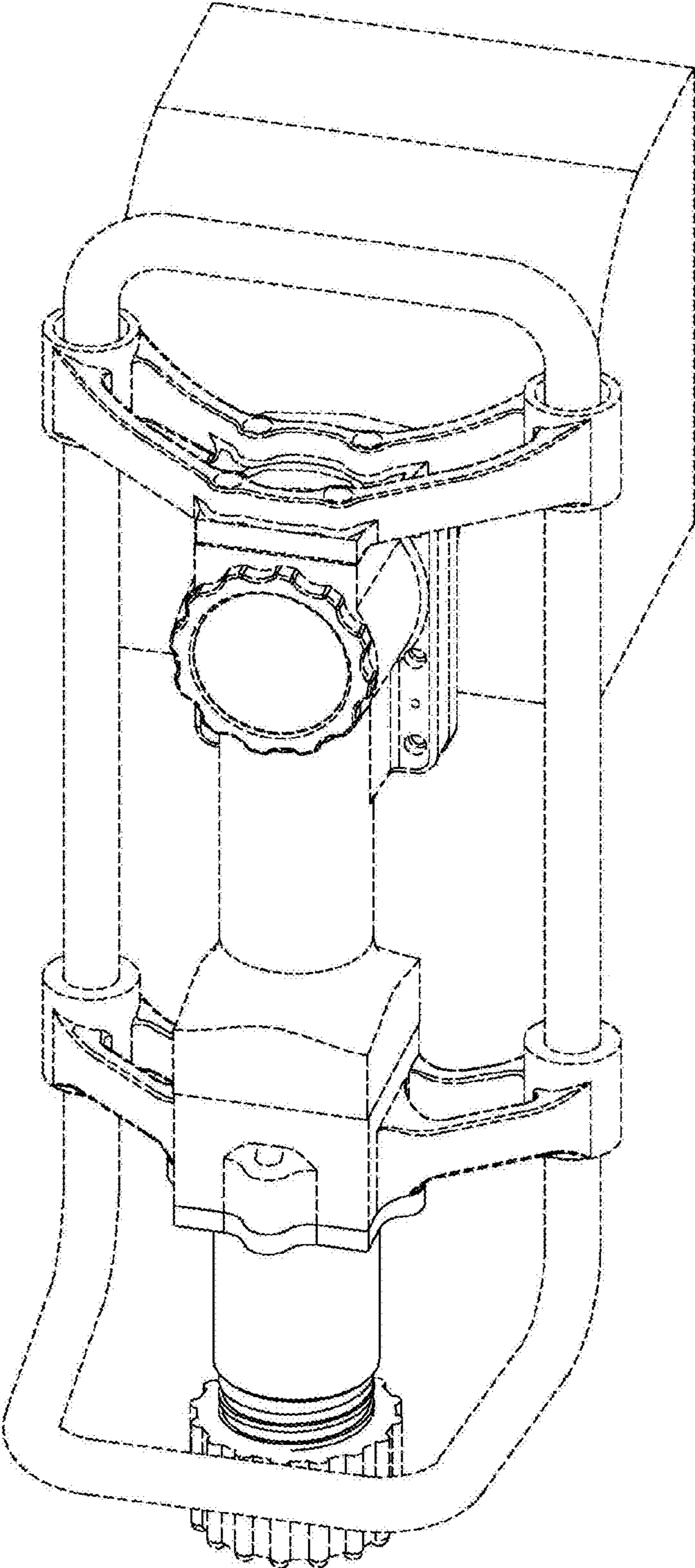

FIG. 1

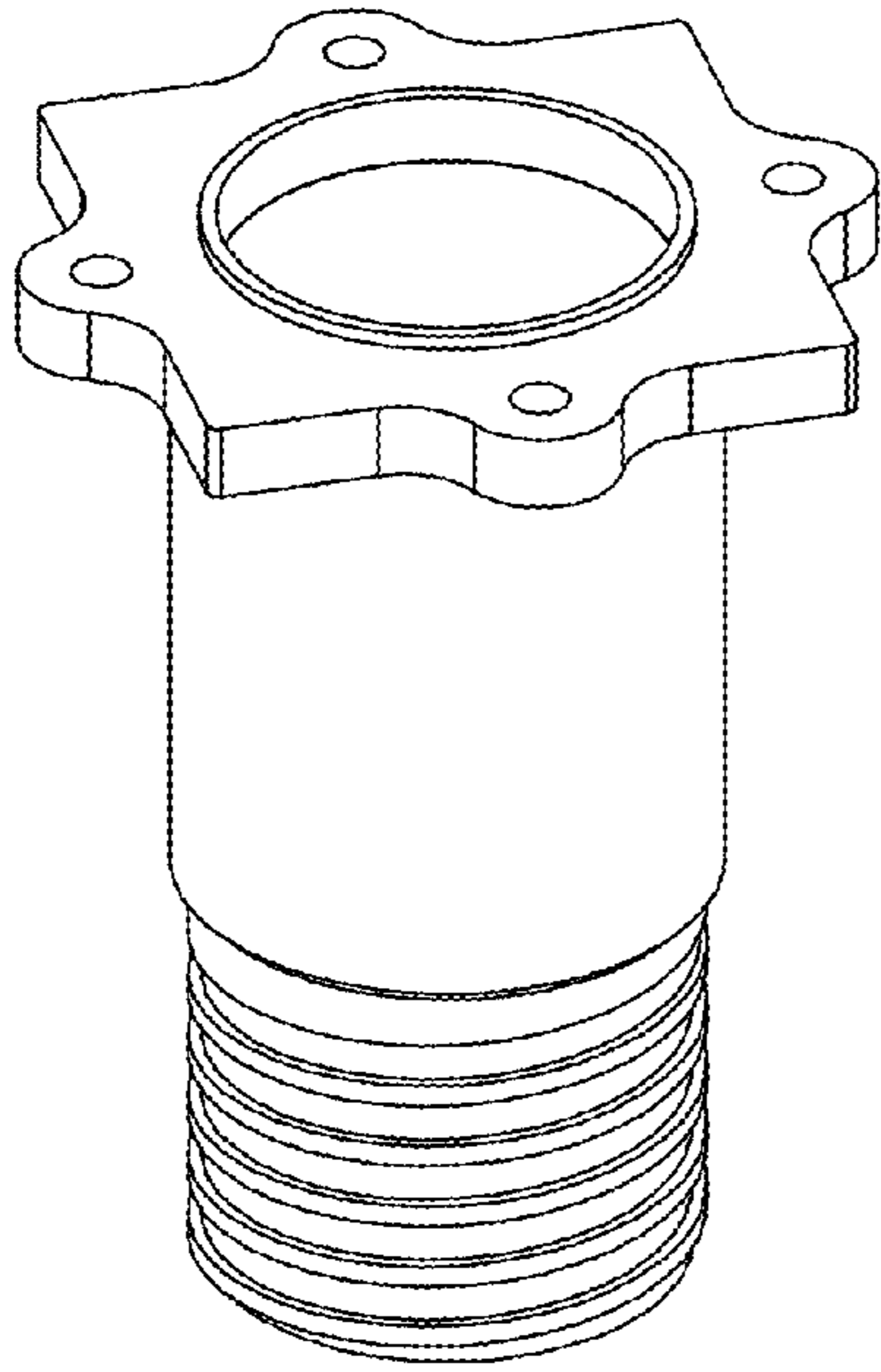

FIG. 2

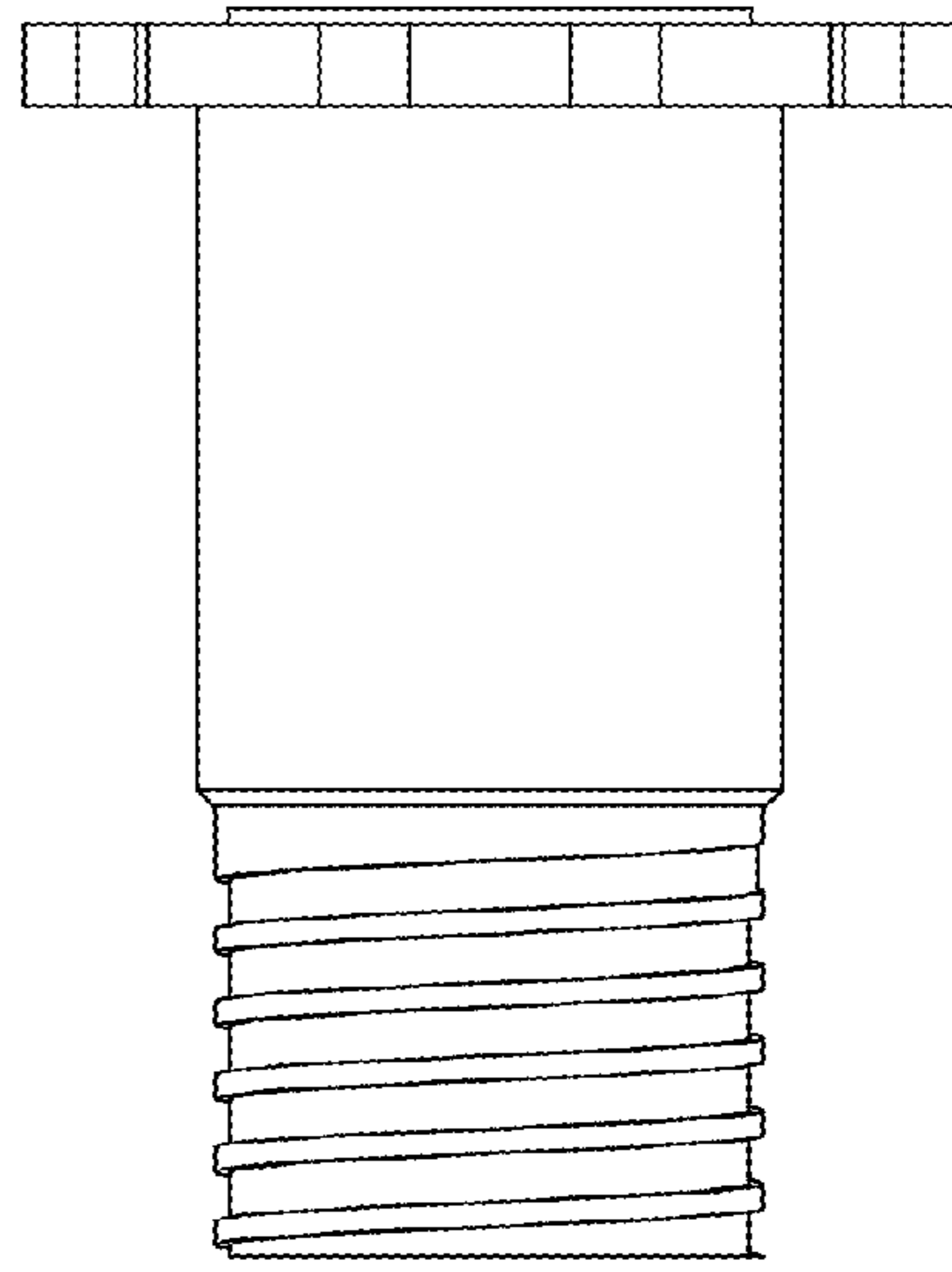

FIG. 3

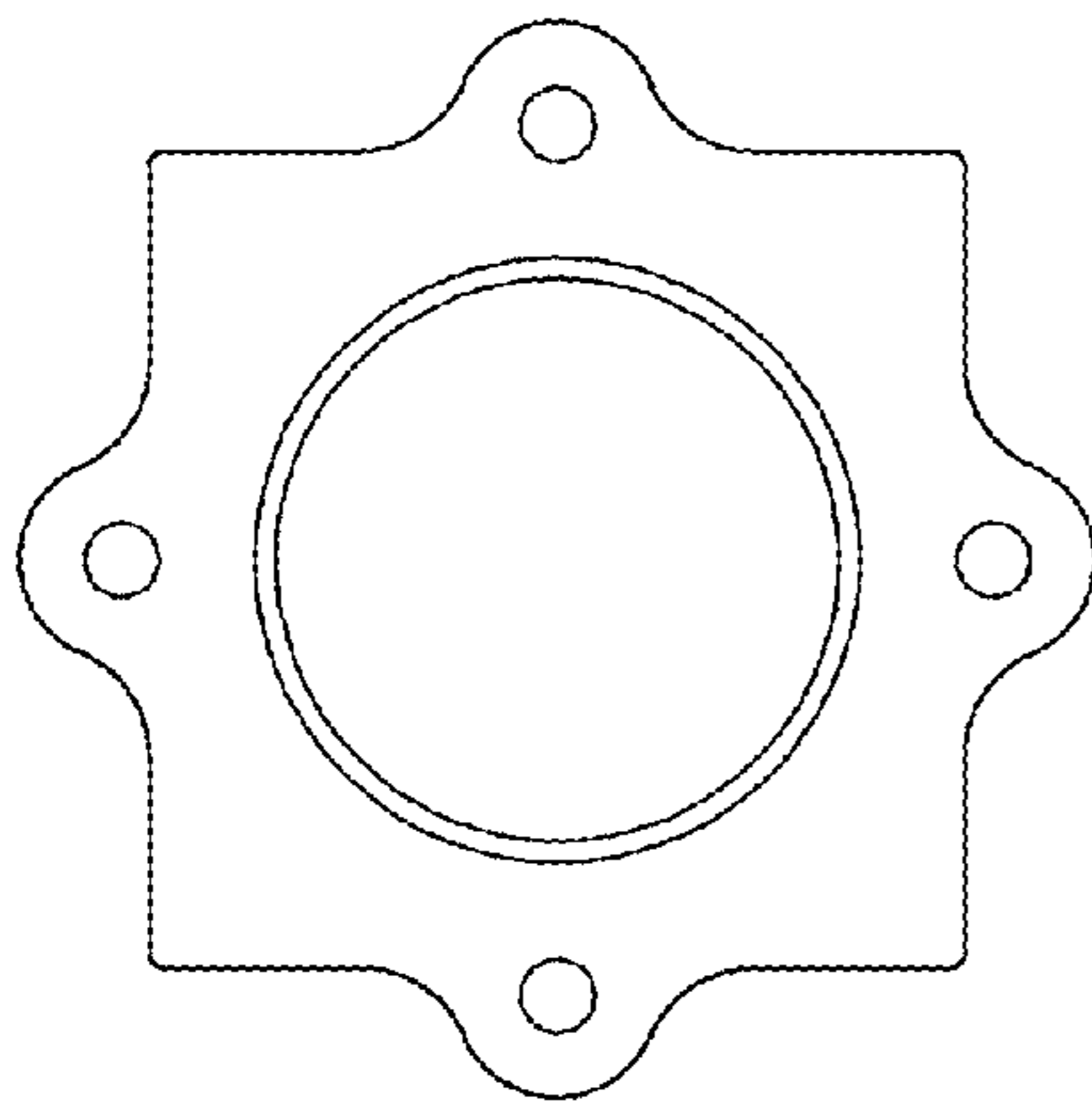

FIG. 4

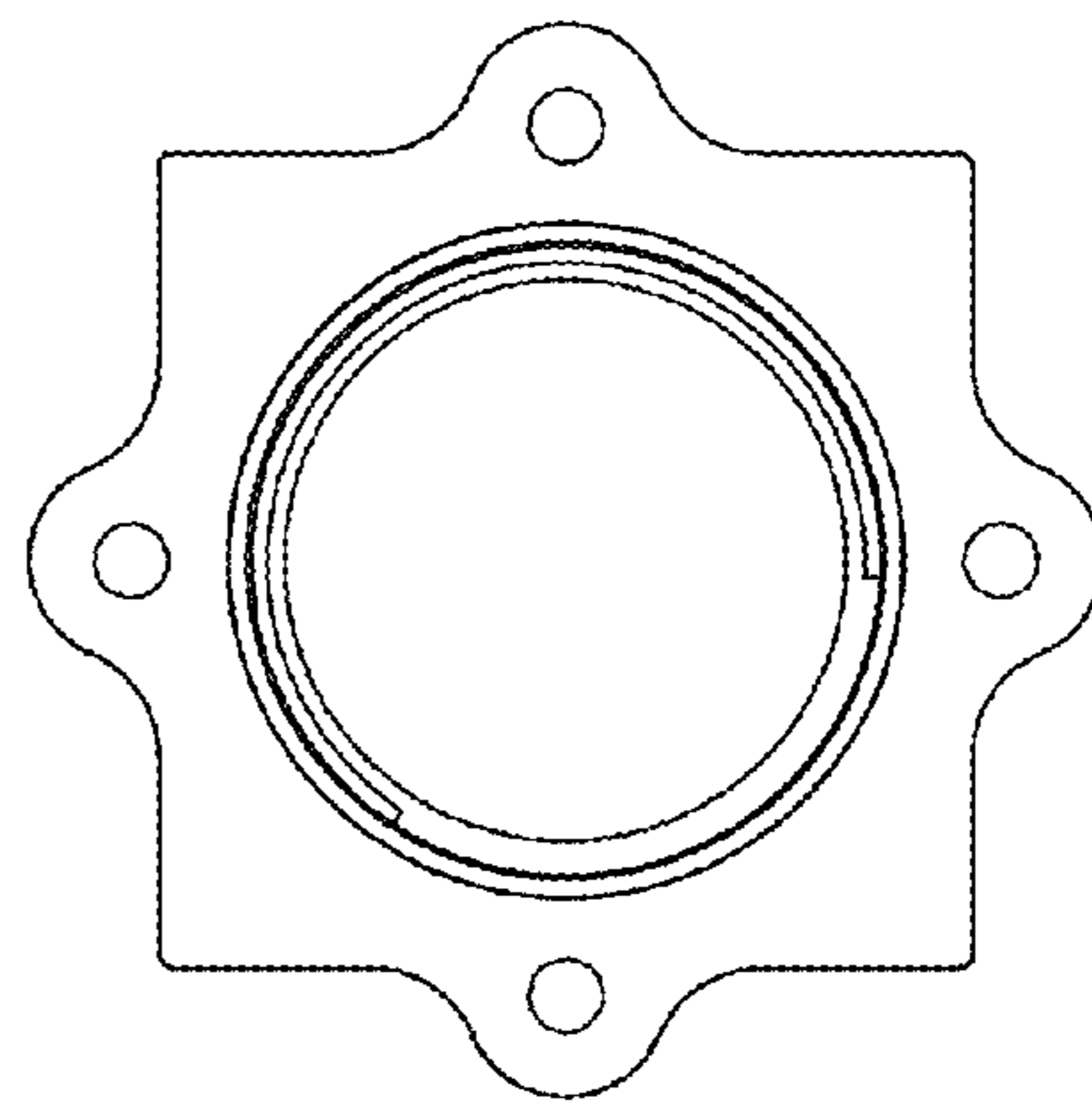

FIG. 5