



US00D733029S

(12) **United States Design Patent**  
**Dutertre**

(10) **Patent No.:** **US D733,029 S**

(45) **Date of Patent:** **\*\* Jun. 30, 2015**

(54) **CARRIER PLANE**

(71) Applicant: **Xavier Gilbert Marc Dutertre,**  
Le-Plessis-Grohan (FR)

(72) Inventor: **Xavier Gilbert Marc Dutertre,**  
Le-Plessis-Grohan (FR)

(\*\*) Term: **14 Years**

(21) Appl. No.: **29/461,529**

(22) Filed: **Jul. 24, 2013**

(51) **LOC (10) Cl.** ..... **12-07**

(52) **U.S. Cl.**  
USPC ..... **D12/319; D12/341; D21/447**

(58) **Field of Classification Search**  
USPC ..... D12/16.1, 319-345; D21/447, 450  
CPC ..... B64C 1/00; B64C 3/00; B64C 3/10;  
B64C 21/00; B64C 23/00; B64C 2025/125;  
B64D 3/00; B64D 5/00; B64D 27/00; B64D  
27/06; B64D 27/26

See application file for complete search history.

(56) **References Cited**

**U.S. PATENT DOCUMENTS**

2,009,296	A *	7/1935	Mayo	244/2
2,843,337	A *	7/1958	Bennett	244/2
2,998,208	A *	8/1961	Di Perna	244/2
3,070,326	A *	12/1962	Griffith	244/2
3,258,228	A *	6/1966	Crook	244/46
3,298,633	A *	1/1967	Dastoli et al.	244/2
D223,869	S *	6/1972	Hurkamp	D12/337

D245,411	S *	8/1977	Sohda et al.	D12/319
4,379,533	A *	4/1983	Caldwell et al.	244/118.1
5,150,860	A *	9/1992	Young	244/63
5,156,353	A *	10/1992	Gliebe et al.	244/54
D352,493	S *	11/1994	Krojer	D12/337
5,465,923	A *	11/1995	Milner	244/2
D430,529	S *	9/2000	Hajek	D12/321
6,398,166	B1 *	6/2002	Ballard et al.	244/158.1
D495,376	S *	8/2004	Zee	D21/450
D628,528	S *	12/2010	Cabezas Carrasco	D12/319
D628,530	S *	12/2010	Gall et al.	D12/345
D633,429	S *	3/2011	Saint-Jalmes et al.	D12/319
7,905,449	B2 *	3/2011	Cazals et al.	244/55

\* cited by examiner

*Primary Examiner* — Martie K Holtje

(74) *Attorney, Agent, or Firm* — RatnerPrestia

(57) **CLAIM**

The ornamental design for a carrier plane, as shown and described.

**DESCRIPTION**

FIG. 1 is a front perspective view of a carrier plane;  
FIG. 2 is a front elevation view thereof;  
FIG. 3 is a rear view elevation view thereof;  
FIG. 4 is a left side elevation view thereof, the right side being a mirror image thereof;  
FIG. 5 is a top plan view thereof; and,  
FIG. 6 is a bottom plan view thereof.  
The structural features depicted by broken lines have been shown for the purpose of illustrating portions of the carrier plane that form no part of the claimed design.

**1 Claim, 6 Drawing Sheets**

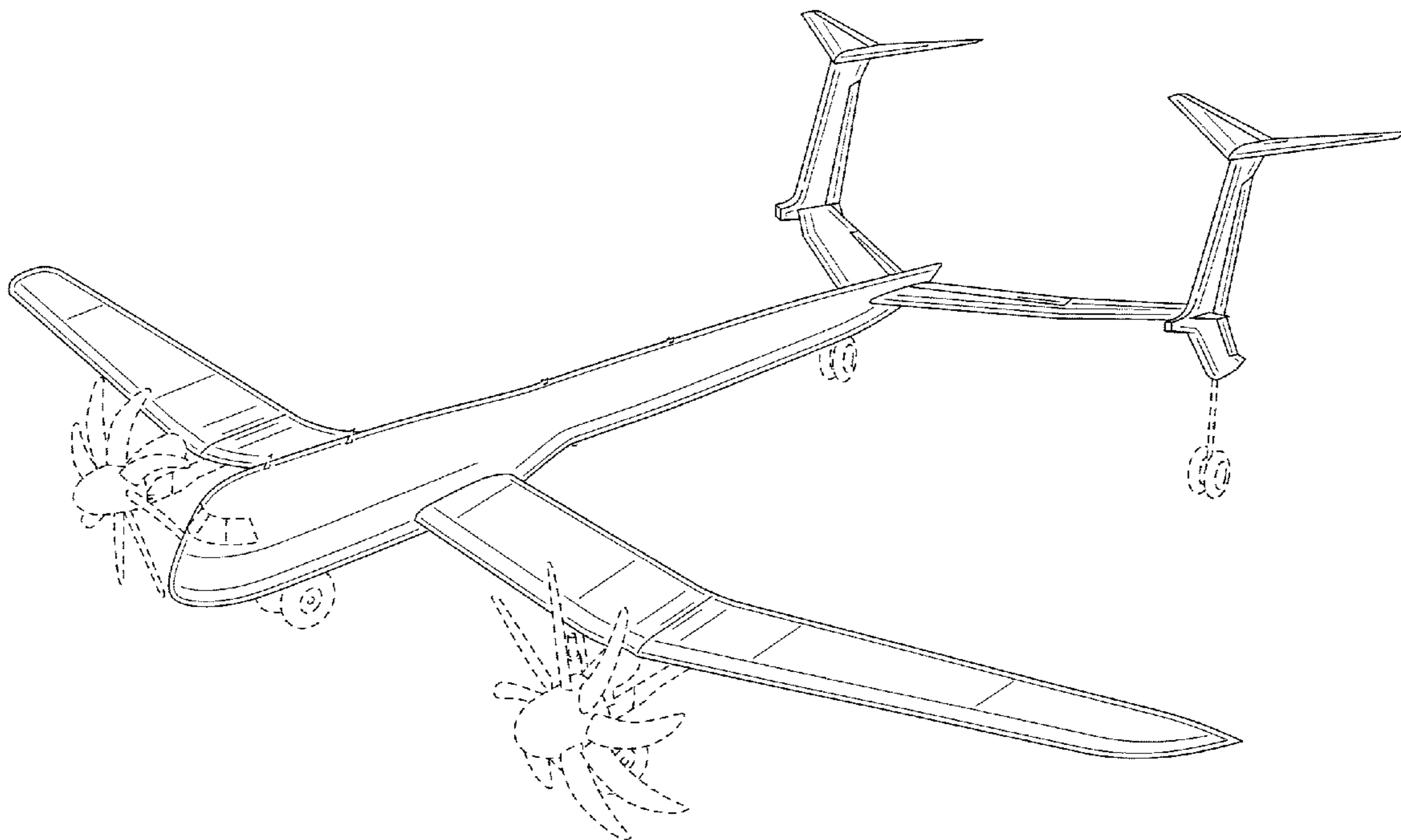

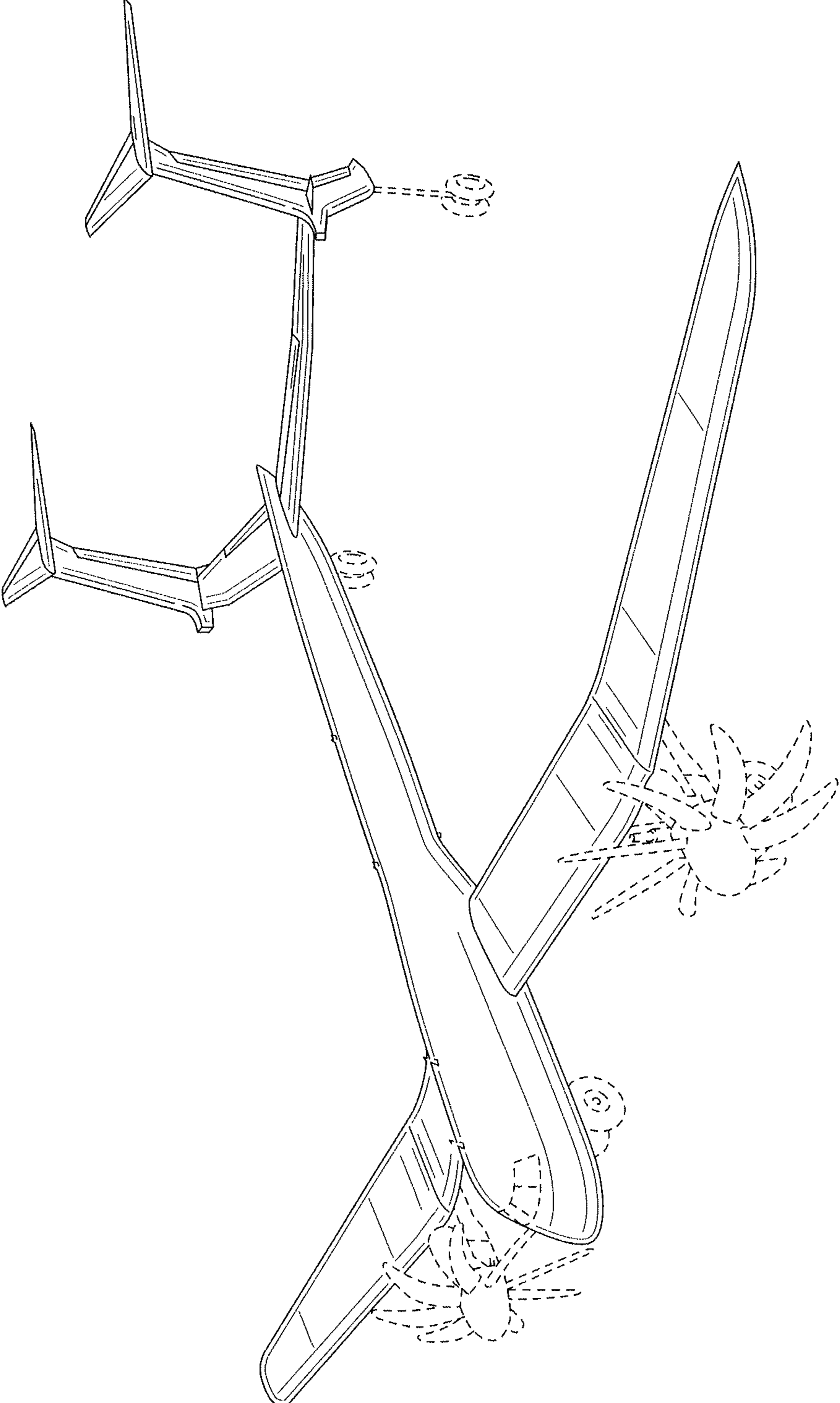

FIG. 1

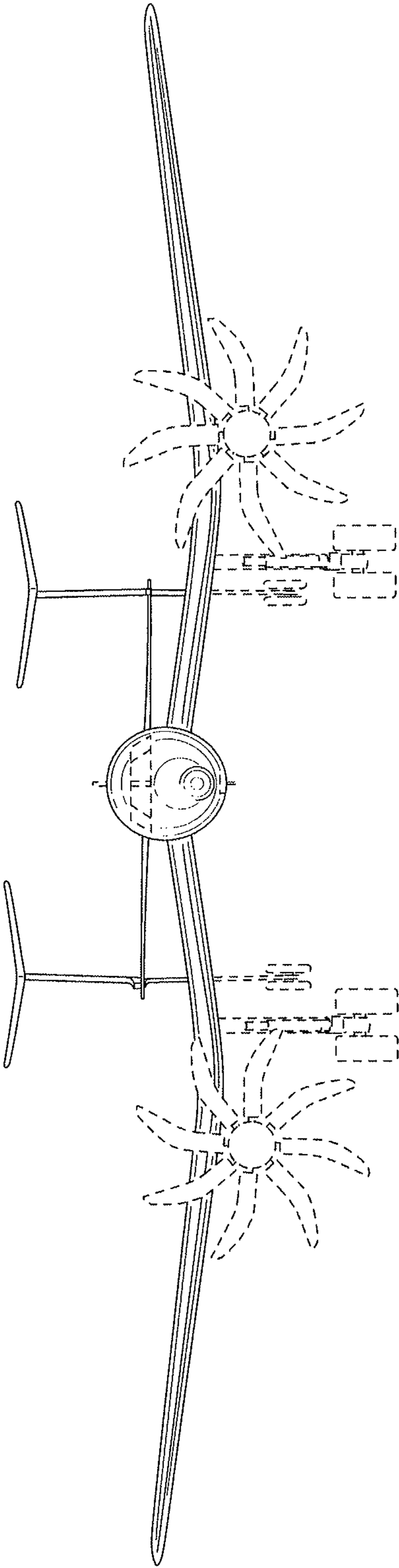

FIG. 2

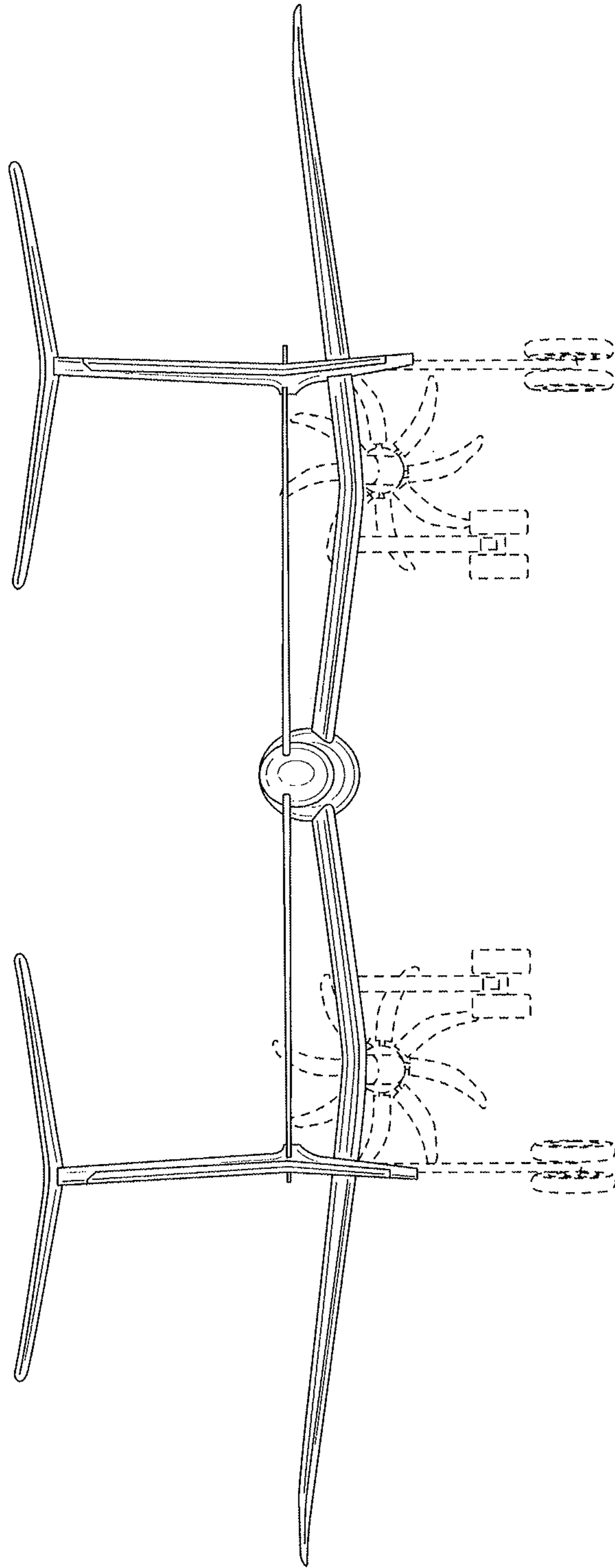

FIG. 3

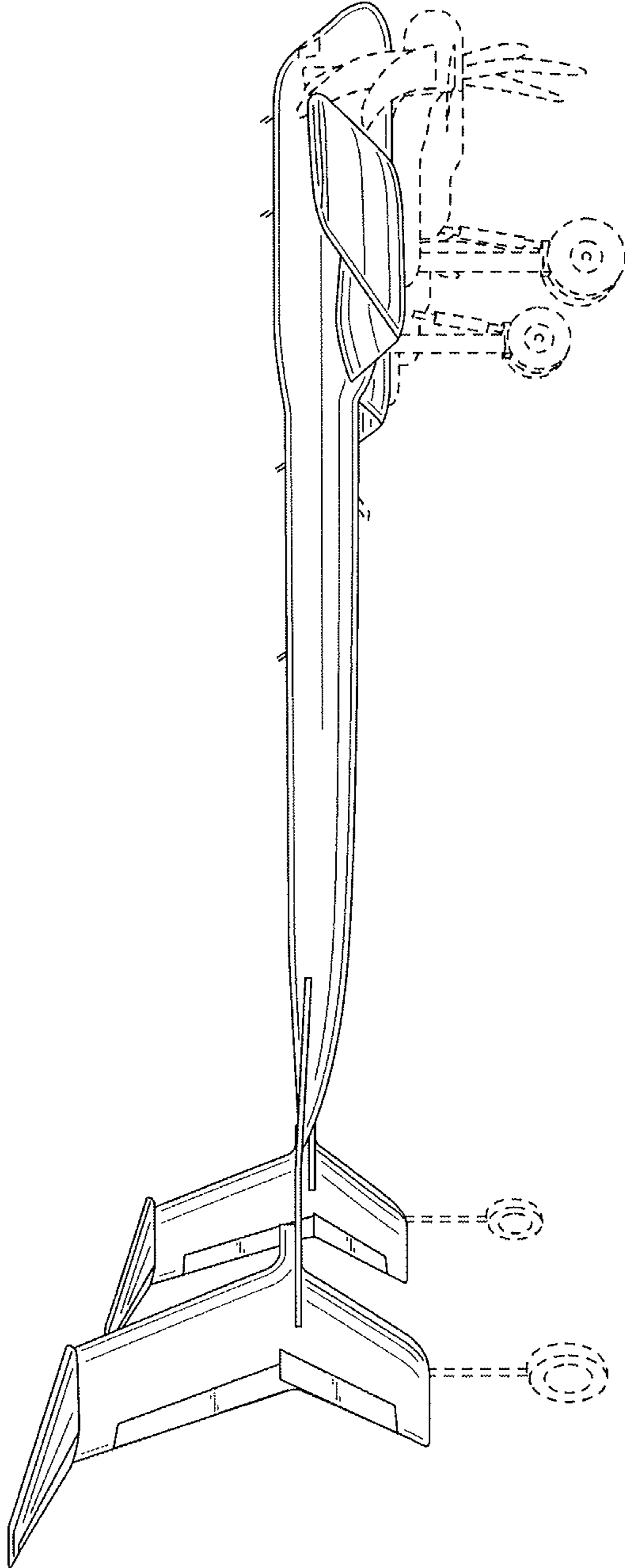

FIG. 4

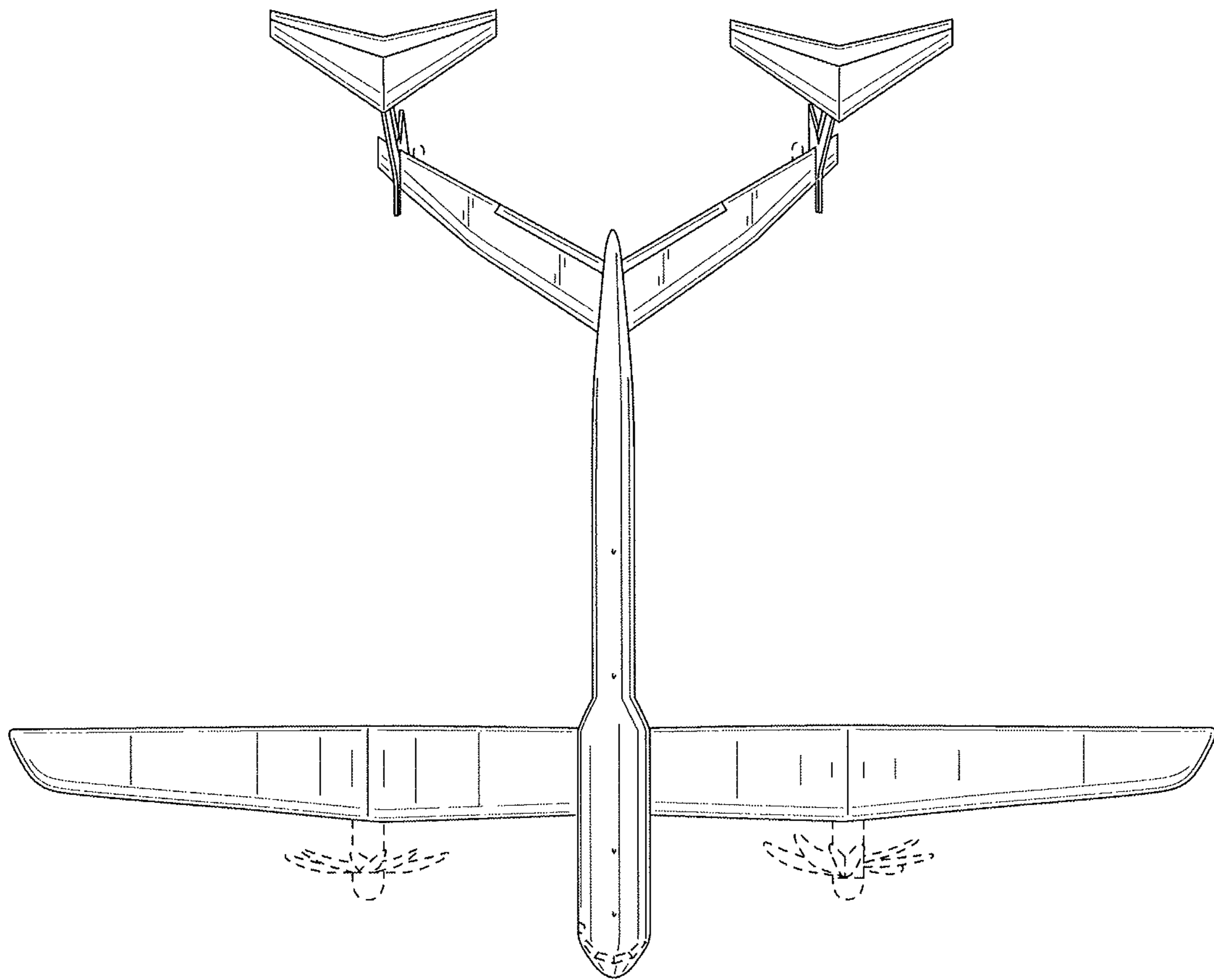

FIG. 5

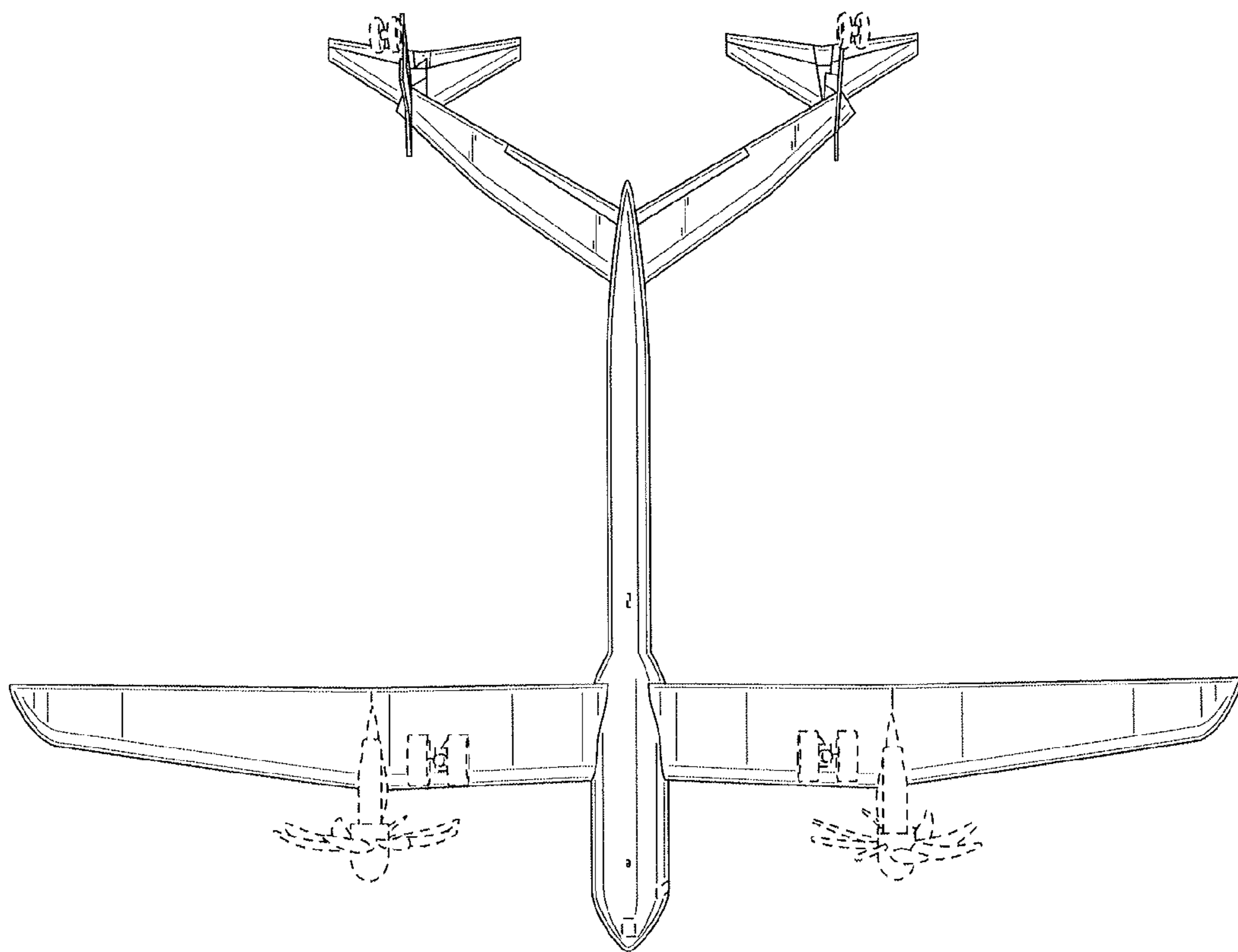

FIG. 6