



US00D732823S

(12) **United States Design Patent**  
**Baron**

(10) **Patent No.:** **US D732,823 S**  
(45) **Date of Patent:** **\*\* Jun. 30, 2015**

(54) **LUGGAGE**

FOREIGN PATENT DOCUMENTS

(71) Applicant: **Samsonite IP Holdings S. a r.l.**,  
Luxembourg (LU)

CN 2904733 5/2007  
CN 201175054 1/2009

(Continued)

(72) Inventor: **Camille Odile Baron**, Central Hong  
Kong (HK)

OTHER PUBLICATIONS

(73) Assignee: **Samsonite IP Holdings S.a r.l.**,  
Luxembourg (LU)

“McQueen’s Quick Silver”, Downloaded at [http://www.style.com/trends/blogs/style\\_file/shopping\\_news/index.html](http://www.style.com/trends/blogs/style_file/shopping_news/index.html), Jul. 17, 2008, 1 pg.

(Continued)

(\*\*) Term: **14 Years**

(21) Appl. No.: **29/462,640**

*Primary Examiner* — Jennifer Rivard

*Assistant Examiner* — April Rivas

(22) Filed: **Aug. 6, 2013**

(74) *Attorney, Agent, or Firm* — Dorsey & Whitney LLP

(30) **Foreign Application Priority Data**

Feb. 8, 2013 (CN) ..... 2013 3 0039432

(51) **LOC (10) Cl.** ..... **03-01**

(52) **U.S. Cl.**

USPC ..... **D3/276; D3/279**

(58) **Field of Classification Search**

USPC ..... D3/272, 276, 278, 279, 273, 274, 281,  
D3/289, 321, 301, 283, 902, 292;  
190/100–127, 903, 37, 39, 18 A;  
206/286–287.1

CPC ..... A47G 29/08; A45C 3/004; A45C 3/00;  
A45C 2003/007; A45C 2003/008; A45C 11/26

See application file for complete search history.

(56) **References Cited**

U.S. PATENT DOCUMENTS

3,044,215 A 7/1962 Crousore  
D299,589 S 1/1989 Uchiyama  
D360,756 S 8/1995 King  
D375,199 S 11/1996 Stokes et al.  
D383,603 S 9/1997 Pedlar  
D383,905 S 9/1997 Stokes et al.

(Continued)

(57) **CLAIM**

The ornamental design for luggage, as shown and described.

**DESCRIPTION**

FIG. 1 shows a front perspective view of a piece of luggage;  
FIG. 2 shows a front elevation view of the piece of luggage of  
FIG. 1;  
FIG. 3 shows a rear elevation view of the piece of luggage of  
FIG. 1;  
FIG. 4 shows a left elevation view of the piece of luggage of  
FIG. 1;  
FIG. 5 shows a right elevation view of the piece of luggage of  
FIG. 1;  
FIG. 6 shows a top view of the piece of luggage of FIG. 1; and,  
FIG. 7 shows a bottom view of the piece of luggage of FIG. 1.  
The broken lines intersecting the top beveled portion of the  
luggage in FIGS. 1 and 4 represent the bounds of the claim.  
The remaining broken lines illustrate portions of the luggage.  
None of the broken lines form part of the claimed design.

**1 Claim, 7 Drawing Sheets**

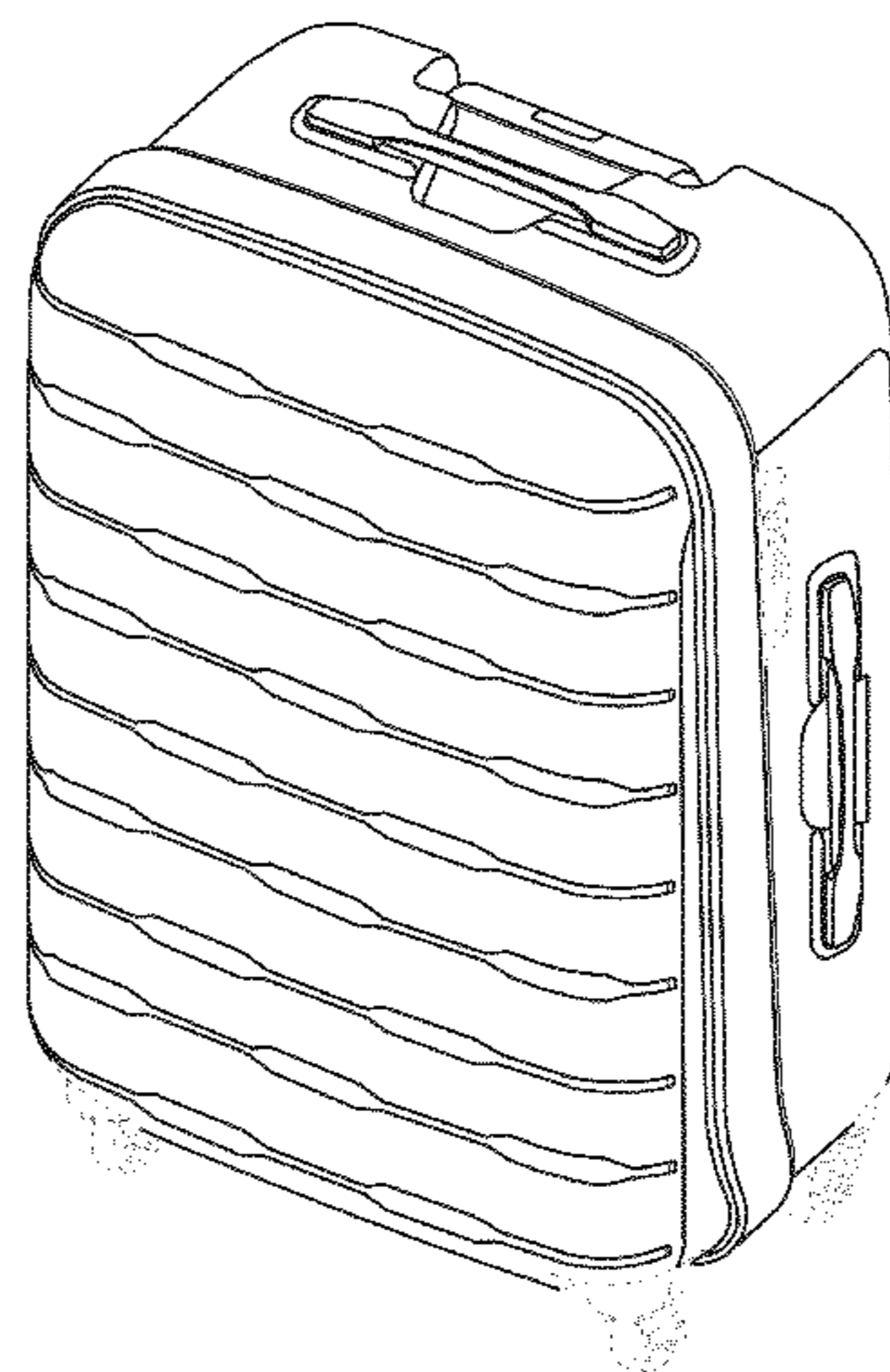

(56)

References Cited

U.S. PATENT DOCUMENTS

D425,301 S 5/2000 Sagol  
 D435,967 S 1/2001 Tiramani et al.  
 6,345,709 B1 2/2002 Cheng  
 D454,430 S \* 3/2002 Sijmons ..... D3/279  
 D462,169 S 9/2002 Giovanni  
 6,499,575 B1 12/2002 Tsai  
 D472,705 S \* 4/2003 Van Himbeeck ..... D3/279  
 6,627,271 B1 9/2003 Okazaki  
 D525,031 S 7/2006 Miles et al.  
 7,143,878 B2 12/2006 Selvi  
 D540,036 S 4/2007 Newson  
 D540,540 S 4/2007 Szyf  
 7,293,649 B2 11/2007 Gelphman et al.  
 D563,101 S \* 3/2008 Kuchler ..... D3/279  
 D581,666 S 12/2008 Sijmons  
 D582,160 S \* 12/2008 Sijmons ..... D3/279  
 D587,902 S 3/2009 Yoneno  
 D627,162 S \* 11/2010 Weng ..... D3/279  
 7,832,533 B2 11/2010 Selvi  
 D629,199 S 12/2010 Minneman  
 D629,200 S 12/2010 Turella-Yuan  
 D633,716 S \* 3/2011 Turella-Yuan et al. .... D3/279  
 D639,555 S 6/2011 Moon  
 D642,379 S 8/2011 Buller  
 D644,434 S 9/2011 Miles et al.  
 D644,435 S 9/2011 Weng  
 D659,395 S \* 5/2012 Sijmons ..... D3/279  
 D664,355 S \* 7/2012 Moon ..... D3/279  
 D665,998 S \* 8/2012 Sijmons ..... D3/279  
 D709,696 S \* 7/2014 Wu ..... D3/279  
 D710,610 S \* 8/2014 Sijmons et al. .... D3/279  
 D711,646 S \* 8/2014 Ke ..... D3/279  
 D711,649 S \* 8/2014 Chen ..... D3/279  
 2004/0188205 A1 9/2004 Badaan  
 2005/0056511 A1 3/2005 Hsieh  
 2005/0183579 A1 8/2005 Bowers  
 2007/0209894 A1 9/2007 Selvi

2007/0237920 A1 10/2007 Schoulz  
 2008/0223678 A1 9/2008 Godshaw et al.  
 2011/0016018 A1 1/2011 Smith et al.  
 2011/0155526 A1 6/2011 Cheng  
 2011/0186396 A1 8/2011 Sheikh  
 2011/0186398 A1 8/2011 Sheikh  
 2011/0284334 A1\* 11/2011 Cheng ..... 190/18 A

FOREIGN PATENT DOCUMENTS

EM 000425285-0007 10/2005  
 EM 000615984-0001 11/2006  
 EM 000709019-0001 4/2007  
 EM 000945175-0001 6/2008  
 EM 000951454-0001 6/2008  
 EM 001003255-0001 9/2008  
 EM 001045520-0001 11/2008  
 EM 001651191-0001 12/2009  
 EM 001212856-0001 4/2010  
 EM 001236632-0001 9/2010  
 EM 001236632-0002 9/2010  
 EM 001236996-0001 9/2010  
 EM 001947789-0003 11/2011  
 EM 001988460-0001 2/2012  
 EM 002136127-0003 11/2012  
 EM 002136127-0004 11/2012  
 EM 002229815-0001 4/2013  
 EM 002310292-0005 10/2013

OTHER PUBLICATIONS

“Suitcases Landor & Hawa (IT Luggage)—the lowest prices in Moscow”, Author Unknown, “Suitcases Landor & Hawa (IT Luggage™)—the lowest prices in Moscow” obtained at URL: [http://sumki-chemodani.ru/?page\\_id=103](http://sumki-chemodani.ru/?page_id=103), on Jul. 2, 2013, the product entitled “Suitcase Landor & Hawa (it luggage™) 00230253 spinner” shown on the Russian version of web-page and English translation as provided in attachment, 7 pages.

\* cited by examiner

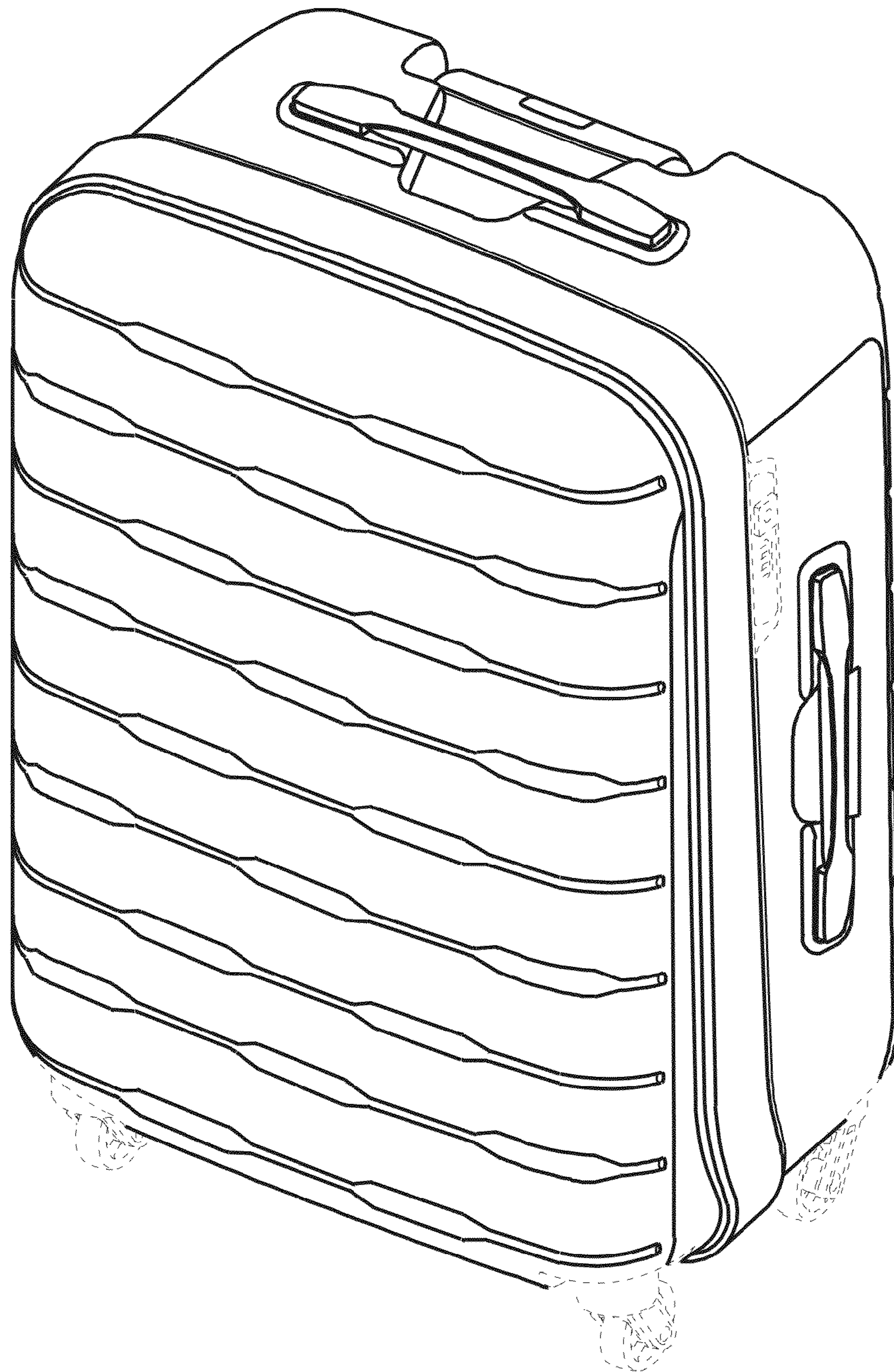

FIG. 1

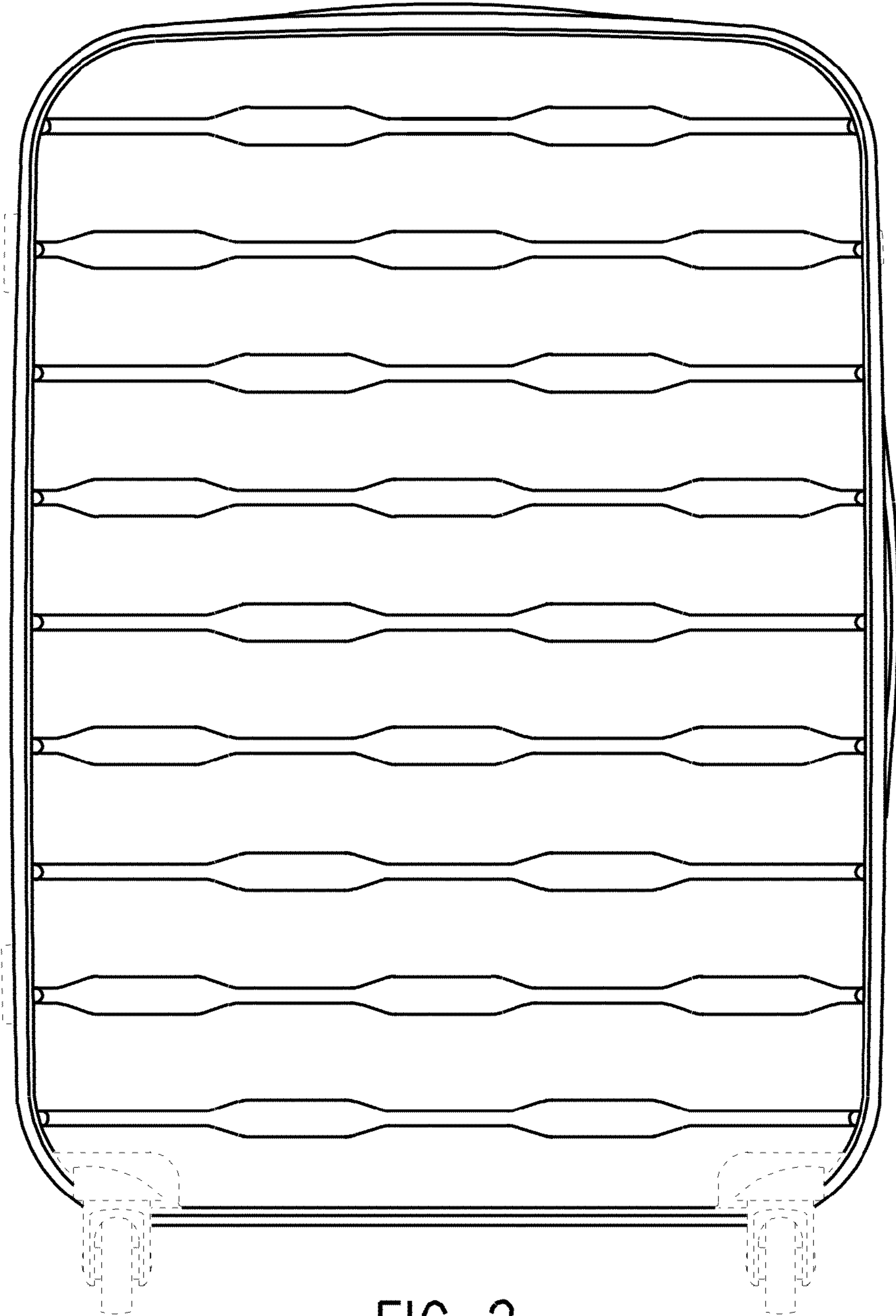

FIG. 2

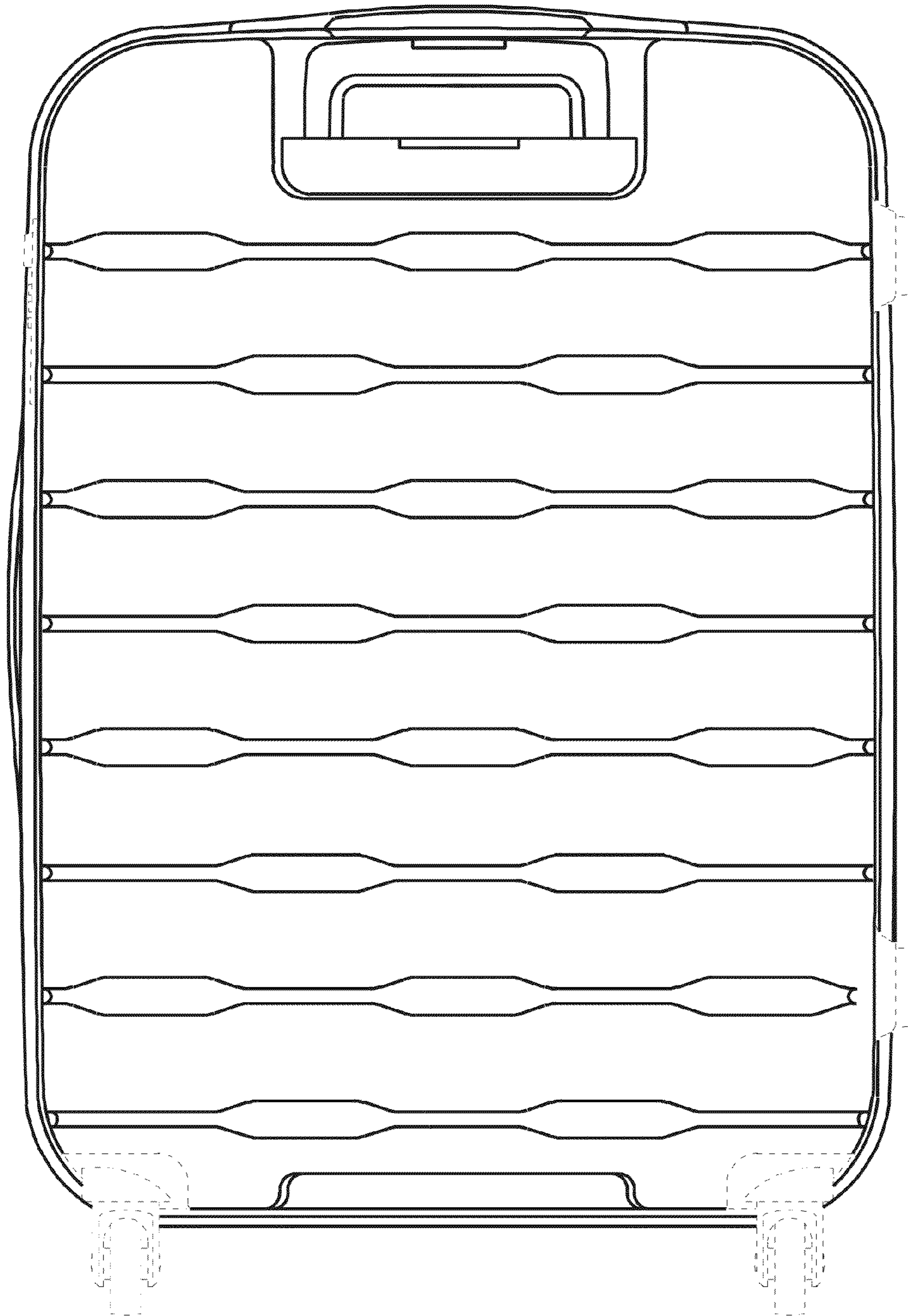

FIG. 3

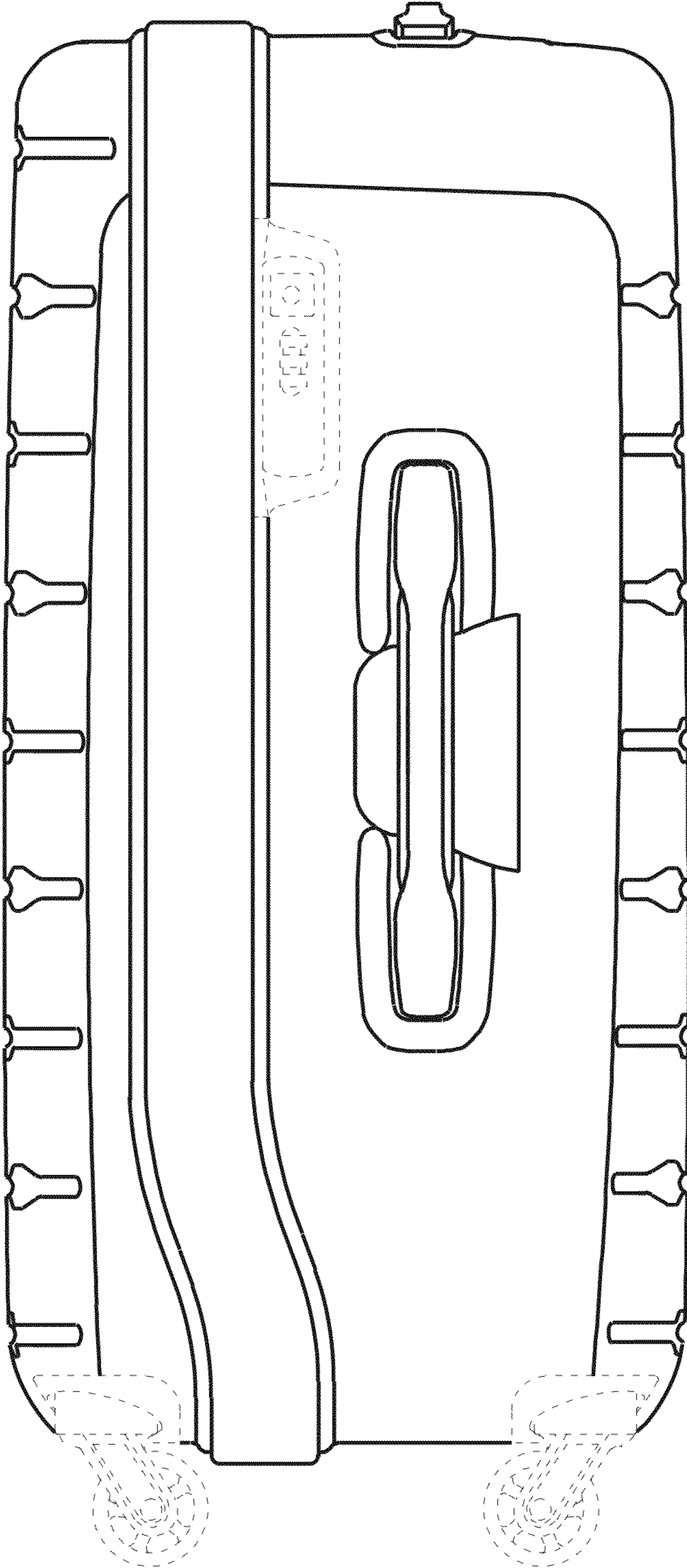

FIG. 4

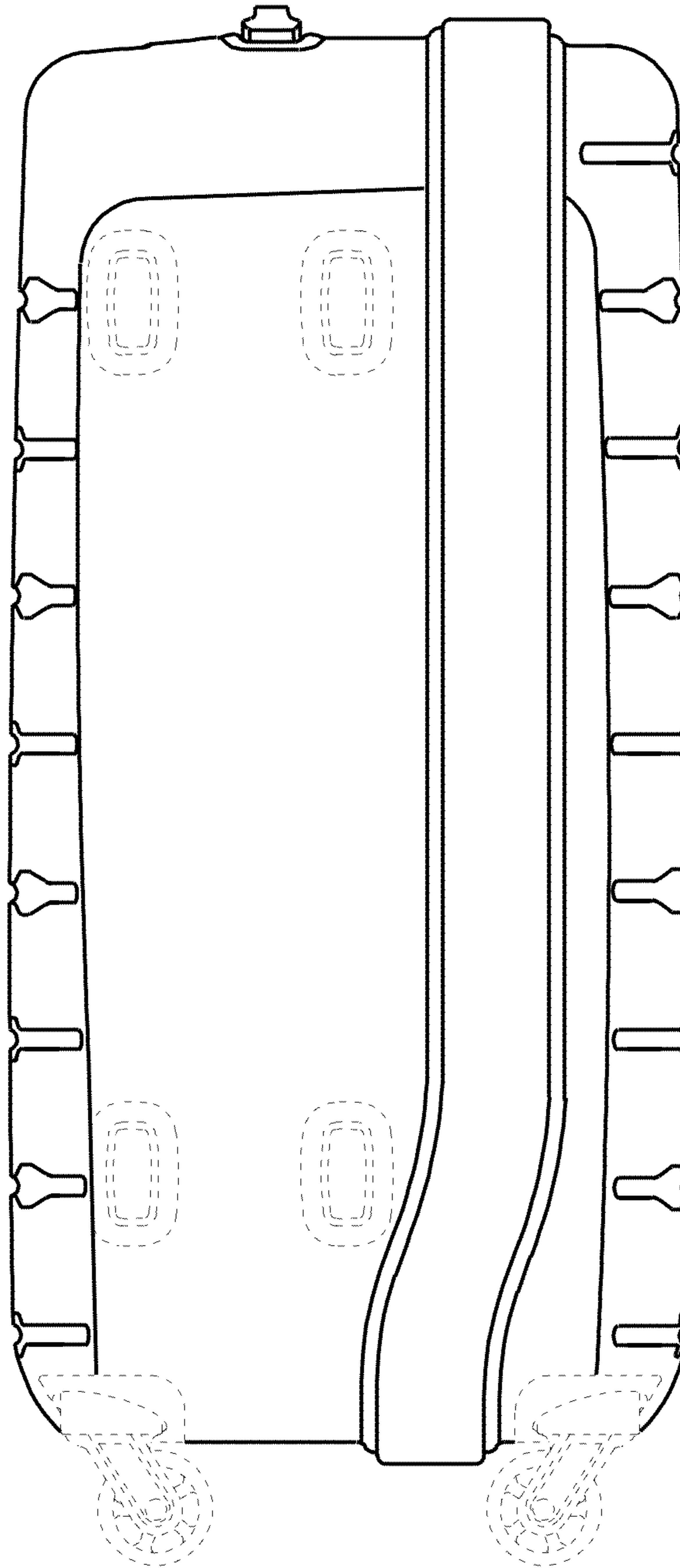

FIG. 5

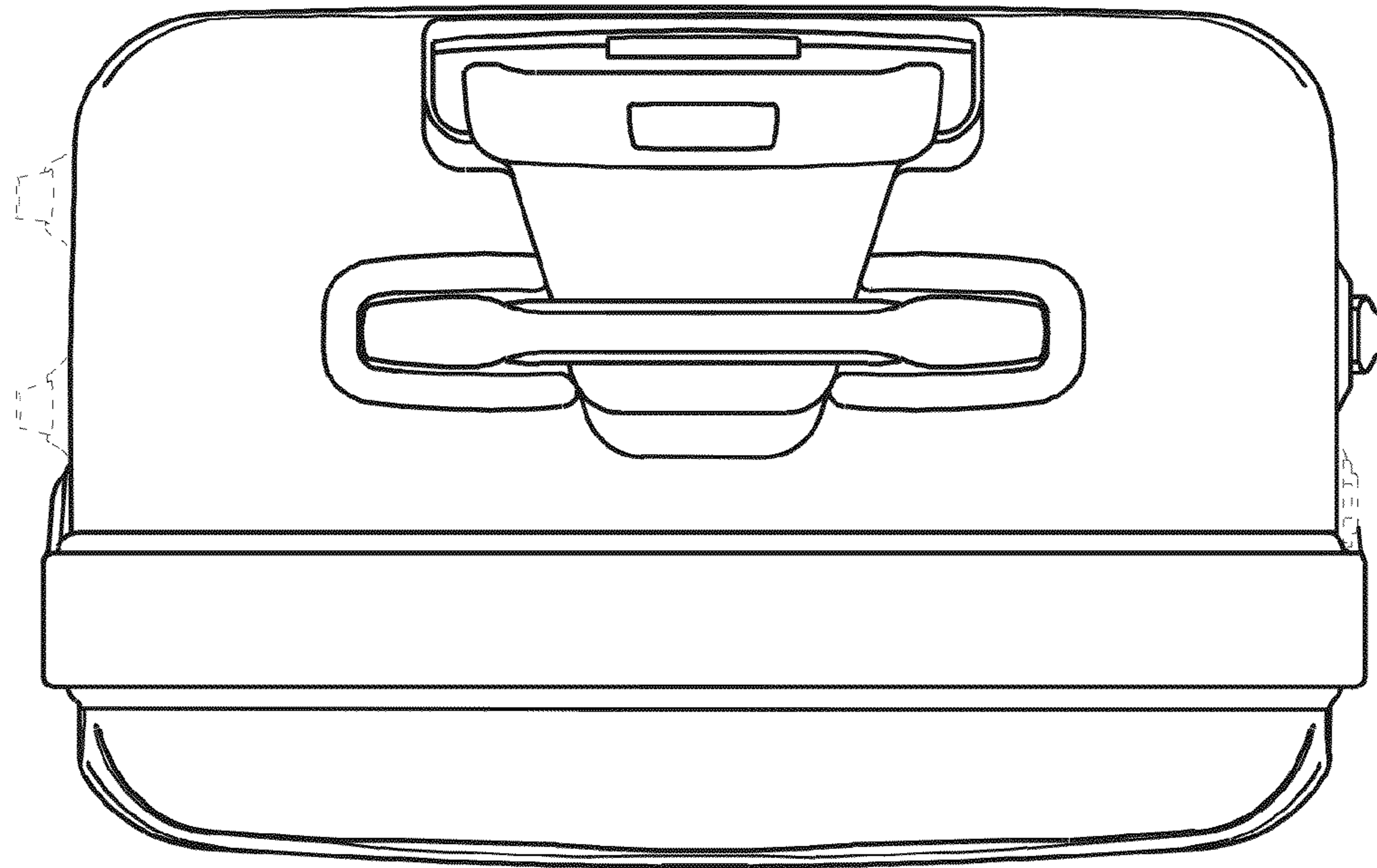

FIG. 6



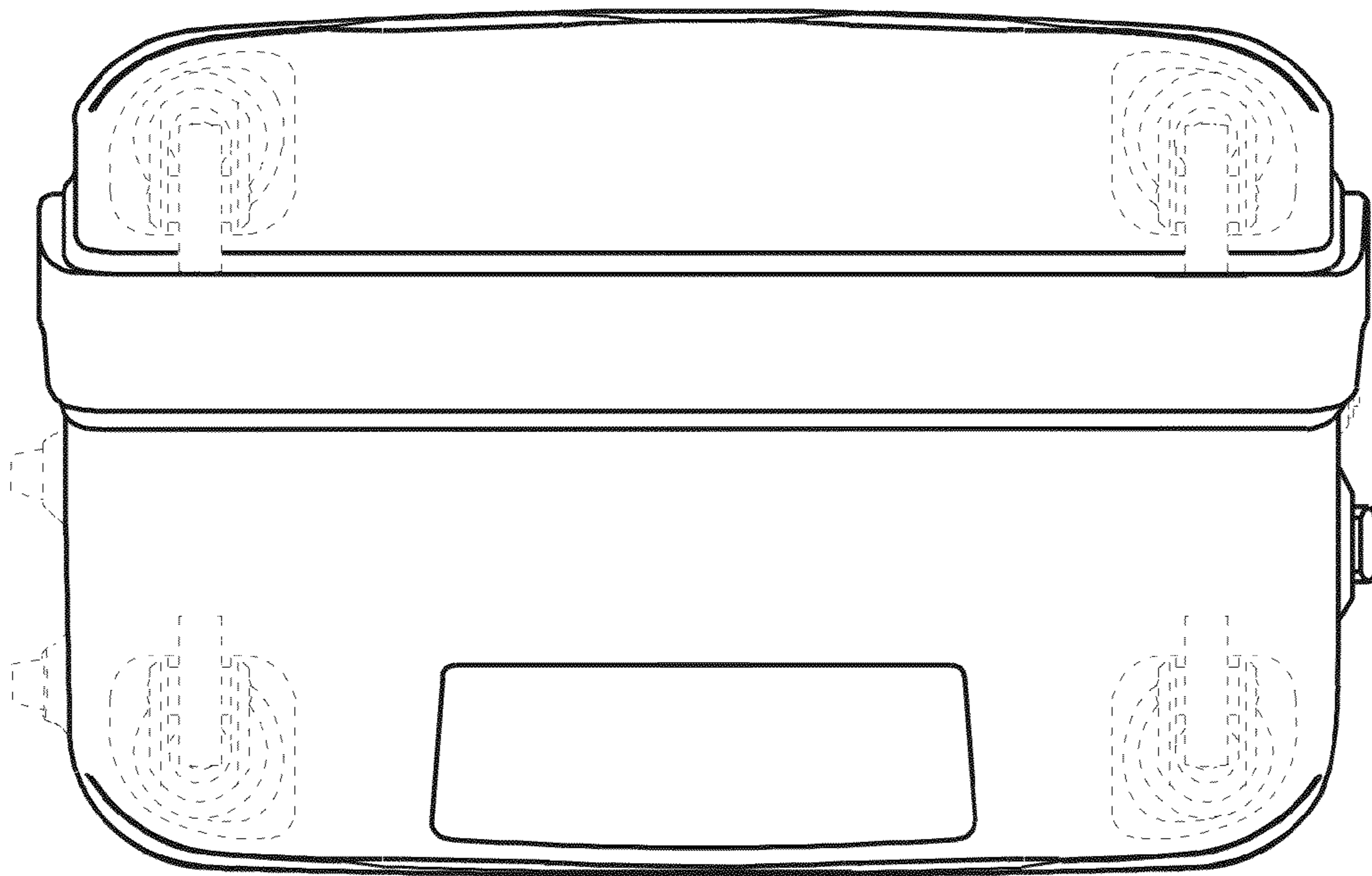

FIG. 7