



US00D732485S

(12) **United States Design Patent**
Junko et al.

(10) **Patent No.:** **US D732,485 S**
(45) **Date of Patent:** **** Jun. 23, 2015**

(54) **MODULAR DIMMER SWITCH WITH A SUBSTANTIALLY SQUARE FOOTPRINT**

(71) Applicant: **Pass & Seymour, Inc.**, Syracuse, NY (US)

(72) Inventors: **Theodore Junko**, Manlius, NY (US);
Taesuk Yang, Wallingford, CT (US);
Phillip Prestigomo, Simsbury, CT (US);
Gerald R. Savicki, Jr., Canastota, NY (US)

(73) Assignee: **Pass & Seymour, Inc.**, Syracuse, NY (US)

(**) Term: **14 Years**

(21) Appl. No.: **29/482,677**

(22) Filed: **Feb. 20, 2014**

Related U.S. Application Data

(62) Division of application No. 29/414,957, filed on Mar. 6, 2012, now Pat. No. Des. 708,151.

(51) **LOC (10) Cl.** **13-03**

(52) **U.S. Cl.**
USPC **D13/169**; D13/170

(58) **Field of Classification Search**
USPC D13/162, 164, 171, 177; 174/66;
200/5 R, 5 A, 1 B, 293, 329, 406, 513,
200/520, 530, 302.1, 302.2, 314, 315, 341,
200/344, 296; 338/198-200; 307/112, 115,
307/125, 139, 157

CPC H01H 9/02; H01H 9/0271; H01H 9/16;
H01H 9/18; H01H 9/161; H01H 9/181;
H01H 9/182; H01H 13/04; H01H 13/14;
H01H 13/20; H01H 13/30; H01H 19/635;
H01H 23/00; H01H 23/02; H01H 23/025;
H01H 23/04; H01H 23/145; H01H 23/148;
H01H 23/205; H01H 23/30; H05B 33/0803;
H05B 33/0863; H05B 37/02; H05B 37/0254;
H05B 37/0272; H05B 39/02; H05B 39/04;
H05B 39/085; H05B 39/086; H05B 39/088

See application file for complete search history.

(56) **References Cited**

U.S. PATENT DOCUMENTS

3,651,296 A 3/1972 Yarbrough
4,808,778 A 2/1989 Fujiyoshi

(Continued)

Primary Examiner — Selina Sikder

(74) *Attorney, Agent, or Firm* — Daniel P. Malley; Bond Schoeneck & King, PLLC

(57) **CLAIM**

The ornamental design for a modular dimmer switch with a substantially square footprint, as shown and described.

DESCRIPTION

FIG. 1 is a full isometric view of the modular dimmer switch, the switch being shown as it comes from the factory on its mounting plate, the plate and integral hardware behind it being shown in environmental lines;

FIG. 2 is a right side elevation view of the switch depicted in FIG. 1;

FIG. 3 is a left side elevation view of the switch depicted in FIG. 1;

FIG. 4 is a top plan view of the switch depicted in FIG. 1;

FIG. 5 is a bottom plan view of the switch depicted in FIG. 1;

FIG. 6 is full isometric view of an alternate embodiment of the modular dimmer switch, the switch being shown as it comes from the factory on its mounting plate, the plate and integral hardware behind it being shown in environmental lines;

FIG. 7 is a right side elevation view of the switch depicted in FIG. 6;

FIG. 8 is a left side elevation view of the switch depicted in FIG. 6;

FIG. 9 is a top plan view of the switch depicted in FIG. 6; and,

FIG. 10 is a bottom plan view of the switch depicted in FIG. 6.

The broken line showing of the environment is for illustrative purposes only and forms no part of the claimed design.

1 Claim, 4 Drawing Sheets

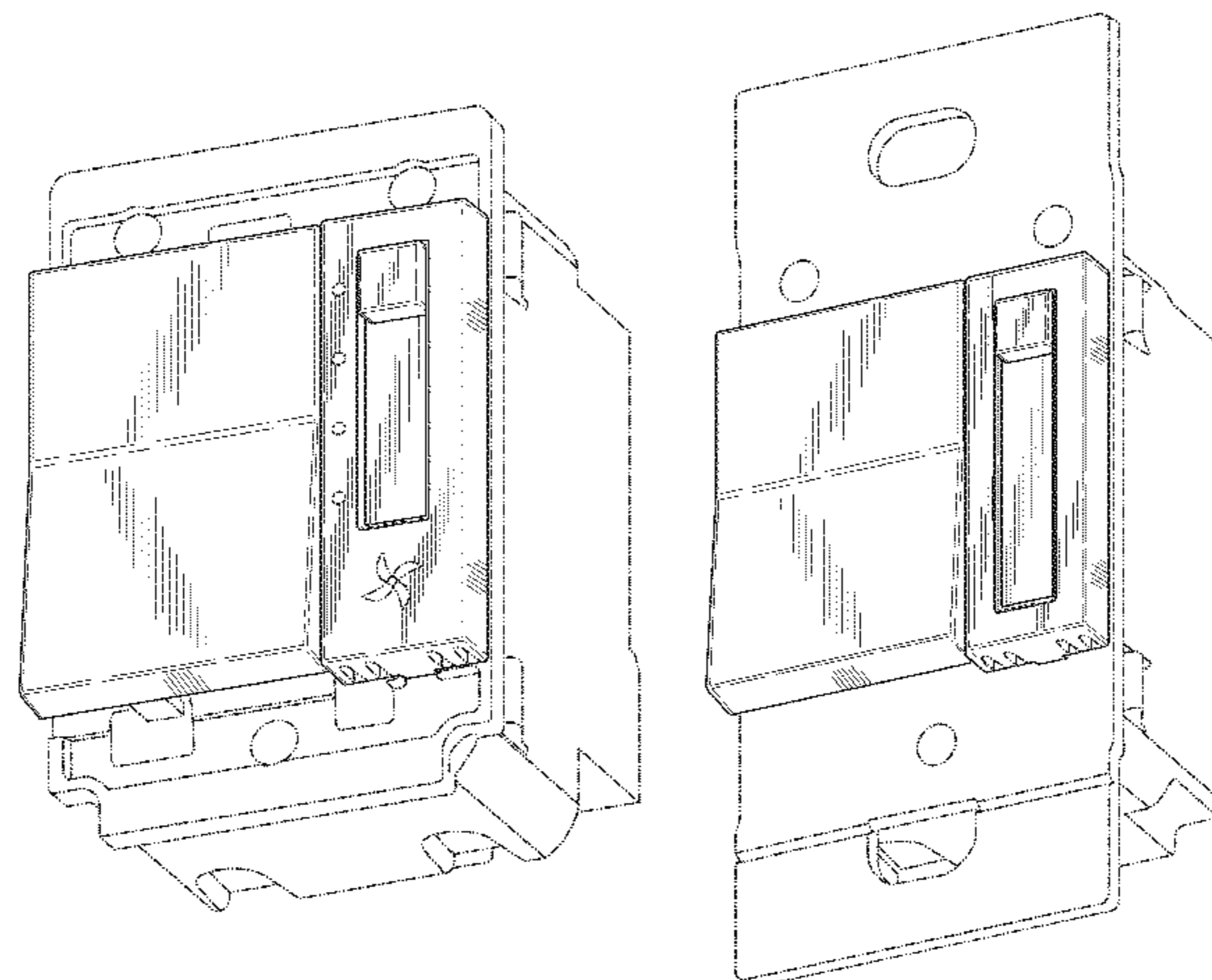

(56)

References Cited

U.S. PATENT DOCUMENTS

5,036,168 A	7/1991	Kikuchi et al.	7,285,723 B2 *	10/2007	Lindenstrauss et al.	174/66
D360,876 S	8/1995	Hughes	D557,662 S	12/2007	Spira	
5,934,451 A	8/1999	Yu et al.	D557,664 S	12/2007	Hewsen et al.	
D440,946 S	4/2001	Yu	D557,665 S	12/2007	Hewsen et al.	
D499,703 S	12/2004	Barone	D559,710 S	1/2008	Jacoby et al.	
6,891,117 B1	5/2005	Gouhl et al.	D560,619 S	1/2008	Hewsen et al.	
6,909,060 B1 *	6/2005	Shotey et al.	D567,767 S	4/2008	Hewsen et al.	
D509,805 S	9/2005	Spira	D569,351 S	5/2008	Hewsen et al.	
D510,073 S	9/2005	Jacoby et al.	D571,312 S	6/2008	Hewsen et al.	
D510,074 S	9/2005	Larson et al.	D572,664 S	7/2008	Hollner et al.	
D518,446 S	4/2006	Hedderich et al.	D572,665 S	7/2008	Hollner et al.	
7,026,564 B1	4/2006	Savicki et al.	D573,546 S	7/2008	Hollner	
D523,824 S	6/2006	Lombardi et al.	D573,956 S	7/2008	Hollner et al.	
D533,844 S	12/2006	Larson et al.	7,400,239 B2 *	7/2008	Kiko et al.	340/501
D534,875 S	1/2007	Wu	D574,333 S	8/2008	Hewson et al.	
D538,755 S	3/2007	Mayo et al.	D576,566 S	9/2008	Wu et al.	
D539,233 S	3/2007	Mayo et al.	D576,958 S	9/2008	Hollner	
D539,236 S	3/2007	Mayo et al.	D580,374 S	11/2008	Hewson et al.	
D539,237 S	3/2007	Mayo et al.	D580,881 S	11/2008	Hollner et al.	
D539,757 S	4/2007	Mayo et al.	D580,882 S	11/2008	Hollner et al.	
D540,266 S	4/2007	Mayo et al.	D580,883 S	11/2008	Hollner	
D540,267 S	4/2007	Larson et al.	D580,884 S	11/2008	Hollner	
D540,748 S	4/2007	Larson et al.	D583,335 S	12/2008	Ni	
D541,221 S	4/2007	Spira	D585,840 S	2/2009	Hollner	
D541,222 S	4/2007	Mayo et al.	D585,841 S	2/2009	Hollner	
D541,223 S	4/2007	Mayo et al.	D586,760 S	2/2009	Hollner et al.	
D541,224 S	4/2007	Mayo et al.	D586,762 S	2/2009	Nichols et al.	
D541,755 S	5/2007	Spira	D588,070 S	3/2009	Hollner et al.	
D542,226 S	5/2007	Spira	D588,071 S	3/2009	Hollner et al.	
D542,227 S	5/2007	Larson et al.	D588,072 S	3/2009	Hollner et al.	
D542,229 S	5/2007	Larson et al.	D588,073 S	3/2009	Hollner	
D542,231 S	5/2007	Mayo et al.	D588,074 S	3/2009	Hollner	
D542,737 S	5/2007	Spira	D588,075 S	3/2009	Hollner	
D543,510 S	5/2007	Larson et al.	D595,663 S	7/2009	Hollner	
D544,450 S	6/2007	Miarta et al.	D595,665 S	7/2009	Hollner	
D545,224 S	6/2007	Sandy et al.	D609,650 S	2/2010	Chou et al.	
D545,770 S	7/2007	Mayo et al.	7,667,155 B1	2/2010	Ni et al.	
D545,771 S	7/2007	Jacoby et al.	D614,589 S	4/2010	Altonen et al.	
D546,293 S	7/2007	Mayo et al.	7,745,750 B2 *	6/2010	Hewson et al.	200/339
D546,775 S	7/2007	Mayo et al.	7,777,145 B2 *	8/2010	Burrell et al.	200/330
D546,776 S	7/2007	Miarta et al.	D649,122 S	11/2011	Jacoby et al.	
D546,777 S	7/2007	Miarta et al.	D649,123 S	11/2011	Jacoby et al.	
D546,778 S	7/2007	Miarta et al.	D651,182 S	12/2011	Alderson et al.	
D546,779 S	7/2007	Miarta et al.	8,138,435 B2 *	3/2012	Patel et al.	200/315
D547,273 S	7/2007	Miarta et al.	8,299,359 B2 *	10/2012	Alderson et al.	174/66
D547,274 S	7/2007	Miarta et al.	8,459,812 B2	6/2013	Wu et al.	
D547,731 S	7/2007	Larson et al.	D708,151 S *	7/2014	Junko et al.	D13/169
D547,732 S	7/2007	Kumar	D709,463 S *	7/2014	Junko et al.	D13/169
D548,194 S	8/2007	Spira	D721,337 S *	1/2015	Junko et al.	D13/169
D551,176 S	9/2007	Hollner	2002/0056628 A1	5/2002	Capella	
D551,177 S	9/2007	Larson et al.	2006/0065510 A1	3/2006	Kiko et al.	
D551,630 S	9/2007	Larson et al.	2007/0193863 A1	8/2007	Wu	
7,265,308 B2 *	9/2007	Endres et al.	2008/0078665 A1	4/2008	Egea Soler	
			2009/0189542 A1	7/2009	Wu et al.	
			2013/0277191 A1 *	10/2013	Trolese et al.	200/501

* cited by examiner

Fig. 1

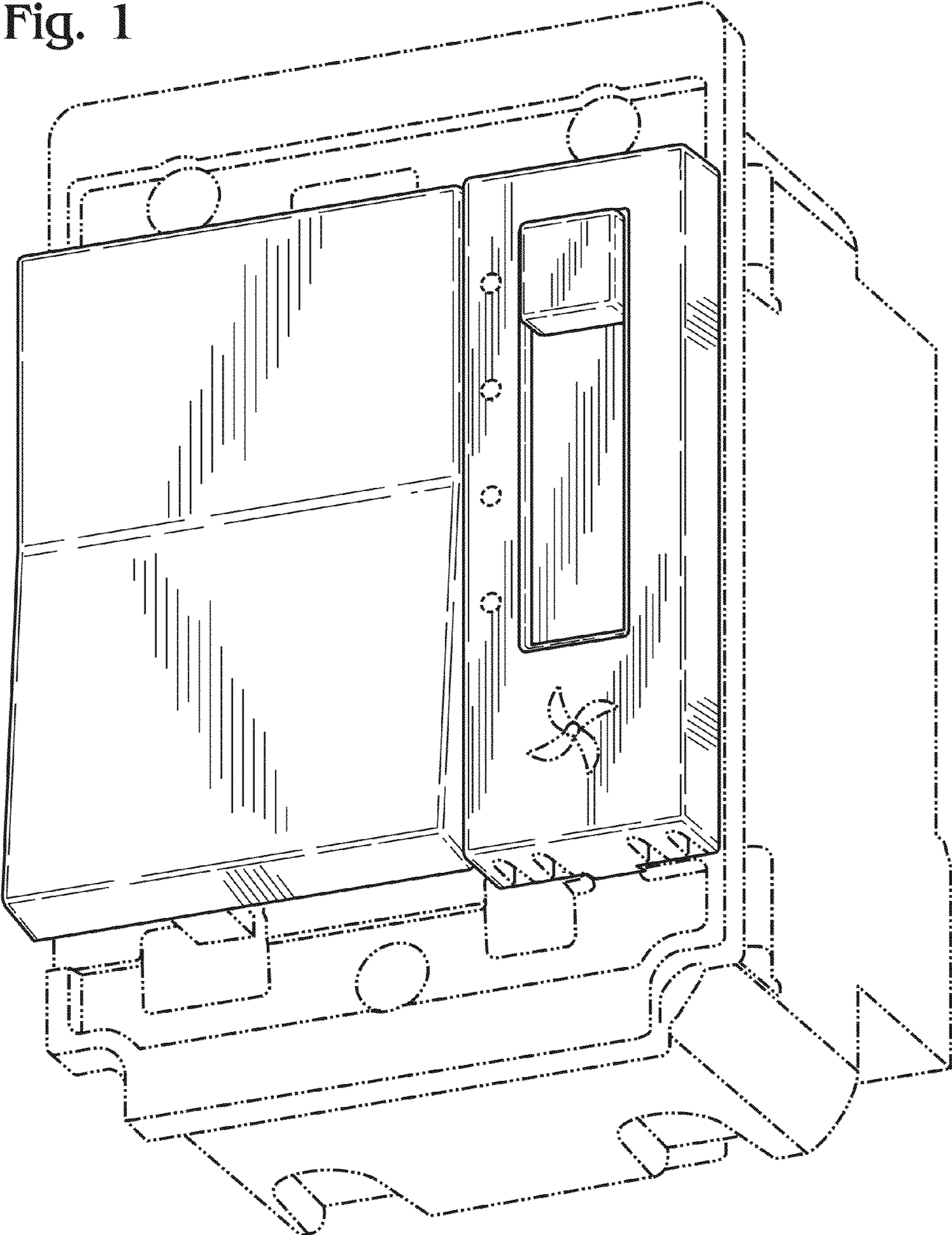

Fig. 2

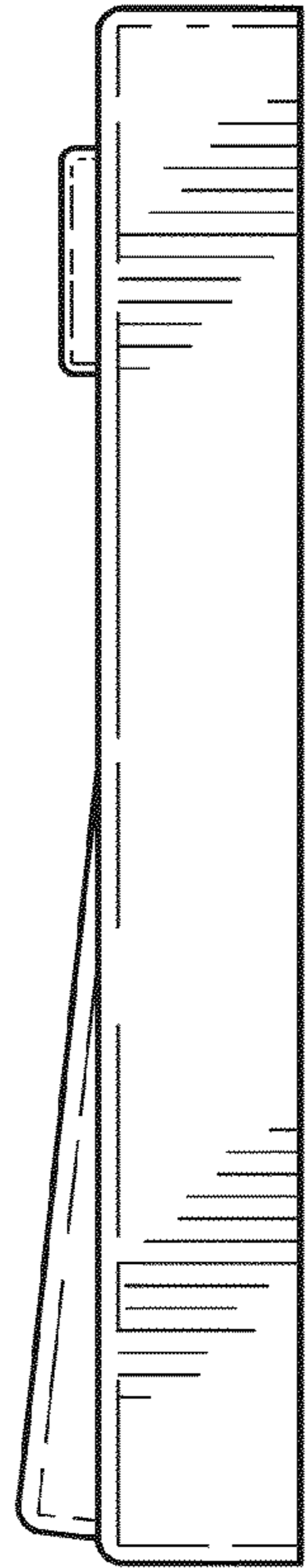

Fig. 3

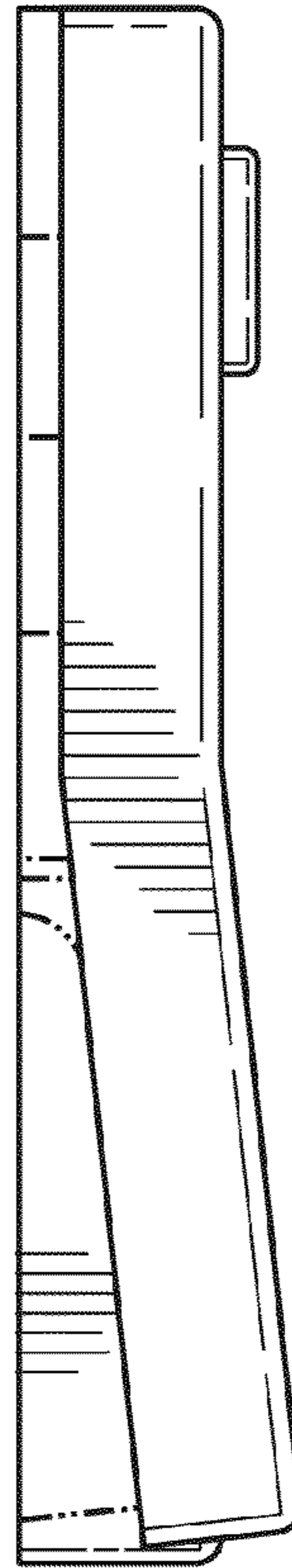

Fig. 4

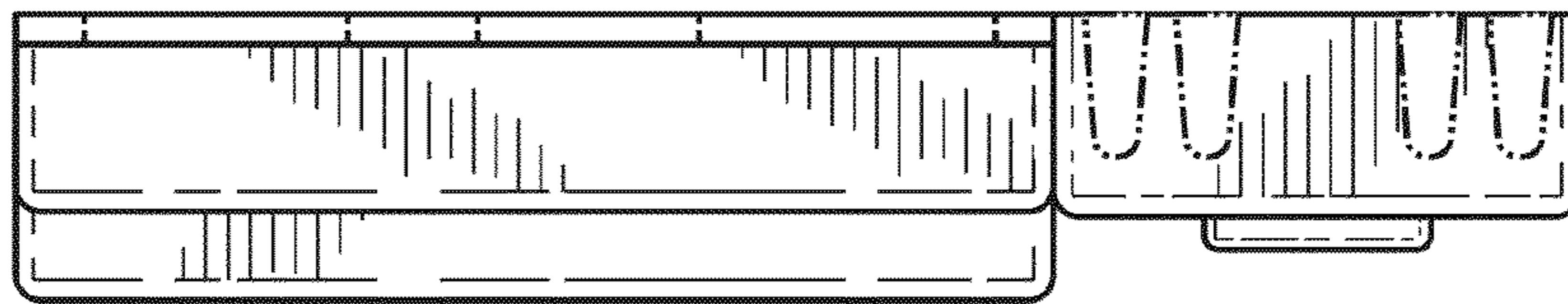

Fig. 5

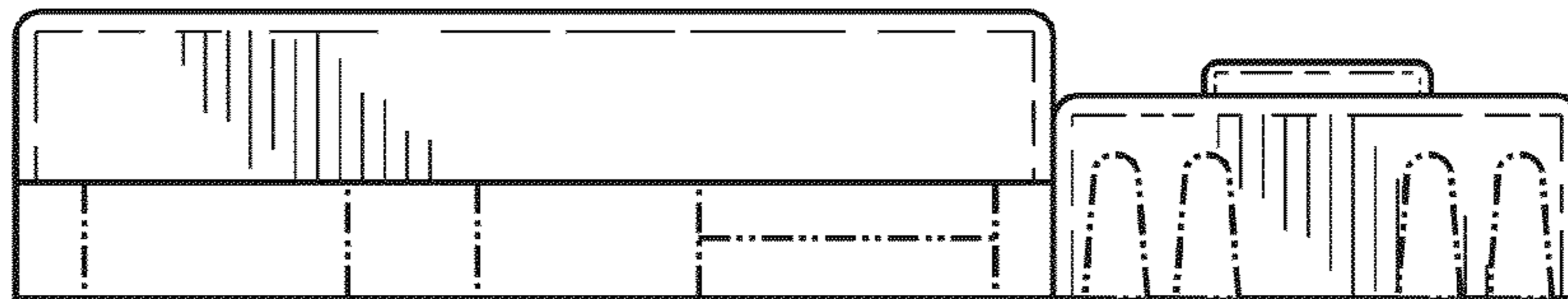

Fig. 6

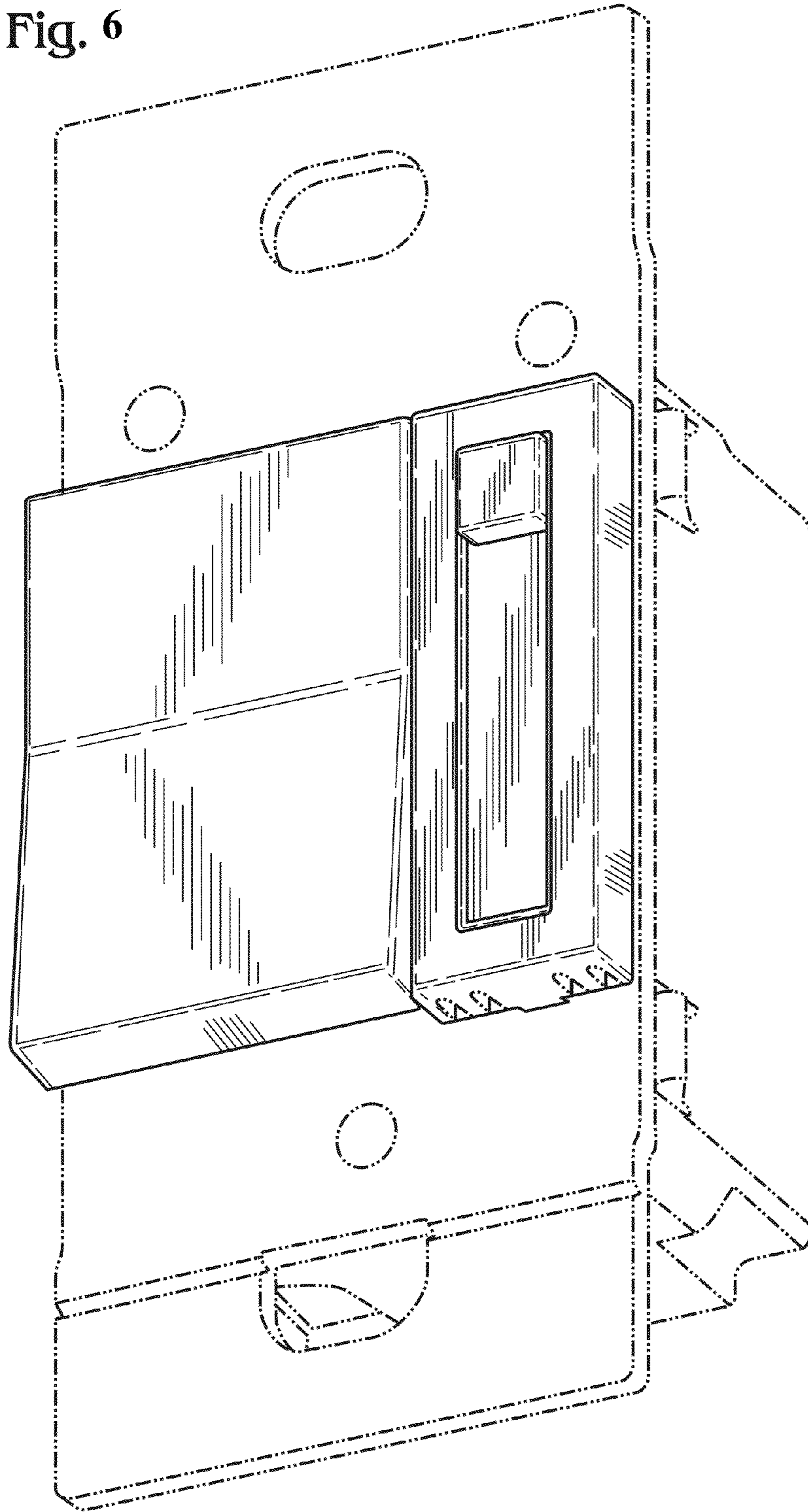

Fig. 7



Fig. 8

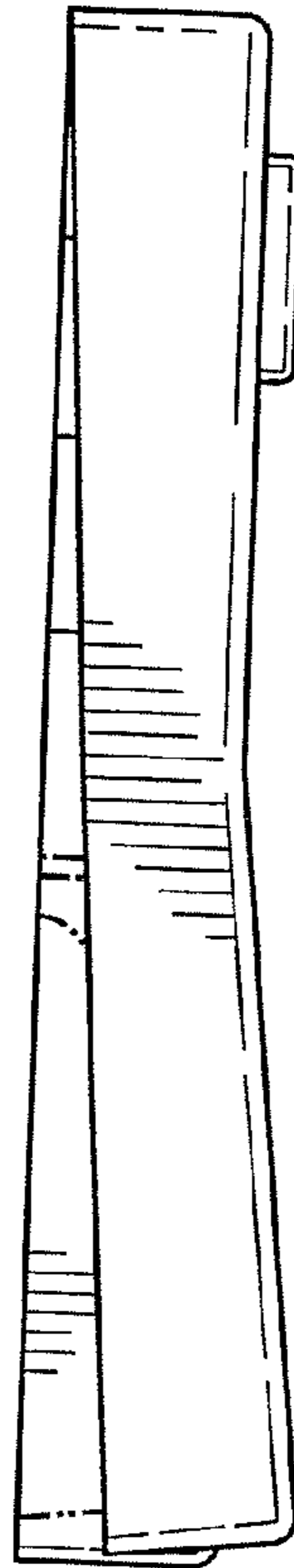

Fig. 9

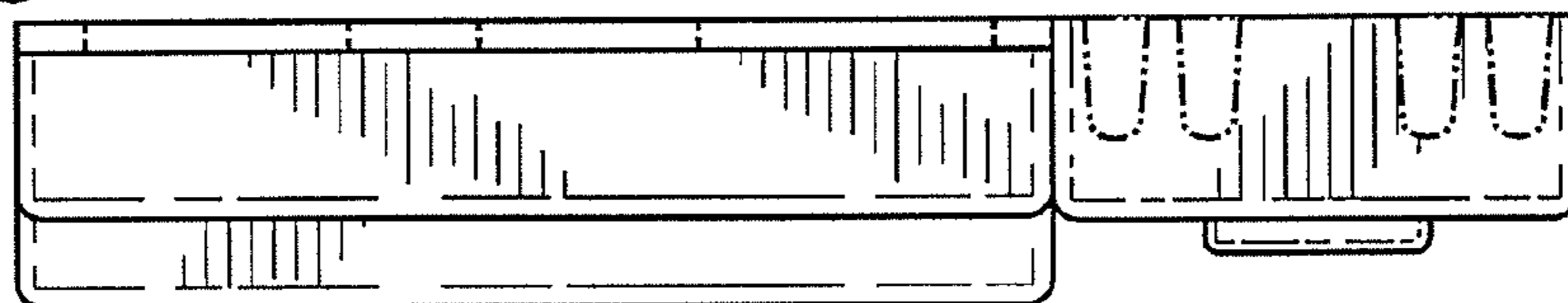

Fig. 10

