



US00D732470S

(12) **United States Design Patent**
Moribe et al.

(10) **Patent No.:** **US D732,470 S**
(45) **Date of Patent:** **** Jun. 23, 2015**

(54) **ELECTRIC VEHICLE CHARGER WITH SINGLE OPENING FOR CONNECTOR OF AN ELECTRIC CABLE**

Primary Examiner — Rosemary K Tarcza
(74) *Attorney, Agent, or Firm* — Posz Law Group, PLC

(71) Applicants: **DENSO WAVE INCORPORATED**, Aichi-pref. (JP); **DENSO CORPORATION**, Aichi-pref. (JP)

(57) **CLAIM**
The ornamental design for an electric vehicle charger with single opening for connector of an electric cable, as shown and described.

(72) Inventors: **Nobuo Moribe**, Obu (JP); **Yuji Tsuchiya**, Nagoya (JP); **Hironobu Ando**, Obu (JP)

DESCRIPTION

(73) Assignees: **DENSO WAVE INCORPORATED**, Aichi-pref. (JP); **DENSO CORPORATION**, Kariya (JP)

FIG. 1 is a perspective view of an electric vehicle charger with single opening for connector of an electric cable;
FIG. 2 is a front view of the electric vehicle charger with single opening for connector of an electric cable;
FIG. 3 is a rear view of the electric vehicle charger with single opening for connector of an electric cable;
FIG. 4 is a right side view of the electric vehicle charger with single opening for connector of an electric cable;
FIG. 5 is a left side view of the electric vehicle charger with single opening for connector of an electric cable;
FIG. 6 is a top view of the electric vehicle charger with single opening for connector of an electric cable;
FIG. 7 is a bottom view of the electric vehicle charger with single opening for connector of an electric cable;
FIG. 8 is an enlarged front view defined by the ranges A-A and B-B of FIG. 2;
FIG. 9 is an enlarged cross-sectional view defined by the ranges A-A and B-B of FIG. 2 and the range M-M of FIG. 4 and taken along the line C-C of FIG. 8;
FIG. 10 is an enlarged top view defined by the ranges D-D and E-E of FIG. 6; and,
FIG. 11 is an enlarged perspective view defined by the ranges X-X and Y-Y of FIG. 1.

(**) Term: **14 Years**

(21) Appl. No.: **29/446,648**

(22) Filed: **Feb. 26, 2013**

(30) **Foreign Application Priority Data**

Aug. 27, 2012 (JP) 2012-020523

(51) **LOC (10) Cl.** **13-02**

(52) **U.S. Cl.**
USPC **D13/107**

(58) **Field of Classification Search**
USPC D13/106–110, 118–119, 184, 199;
D15/9; 320/103–115; D6/310–312,
D6/301–302

See application file for complete search history.

(56) **References Cited**

U.S. PATENT DOCUMENTS

D231,901 S *	6/1974	Bentley	D8/371
D241,299 S *	9/1976	Ohls	D6/301
D332,528 S *	1/1993	Neal	D6/301
D337,303 S *	7/1993	Naft et al.	D13/108
D340,811 S *	11/1993	Vaughan	D6/310

(Continued)

The broken line showing of a body, a connector and an electric cable is for the purpose of illustrating unclaimed portions of the electric vehicle charger and forms no part of the claimed design.

The electric vehicle charger includes, a body, an electric cable extending from the body and a connector provided at an end of the electric cable. As shown in the perspective view, the connector is supported by the body via an opening which is formed in an inclined surface of an upper part of the body.

1 Claim, 11 Drawing Sheets

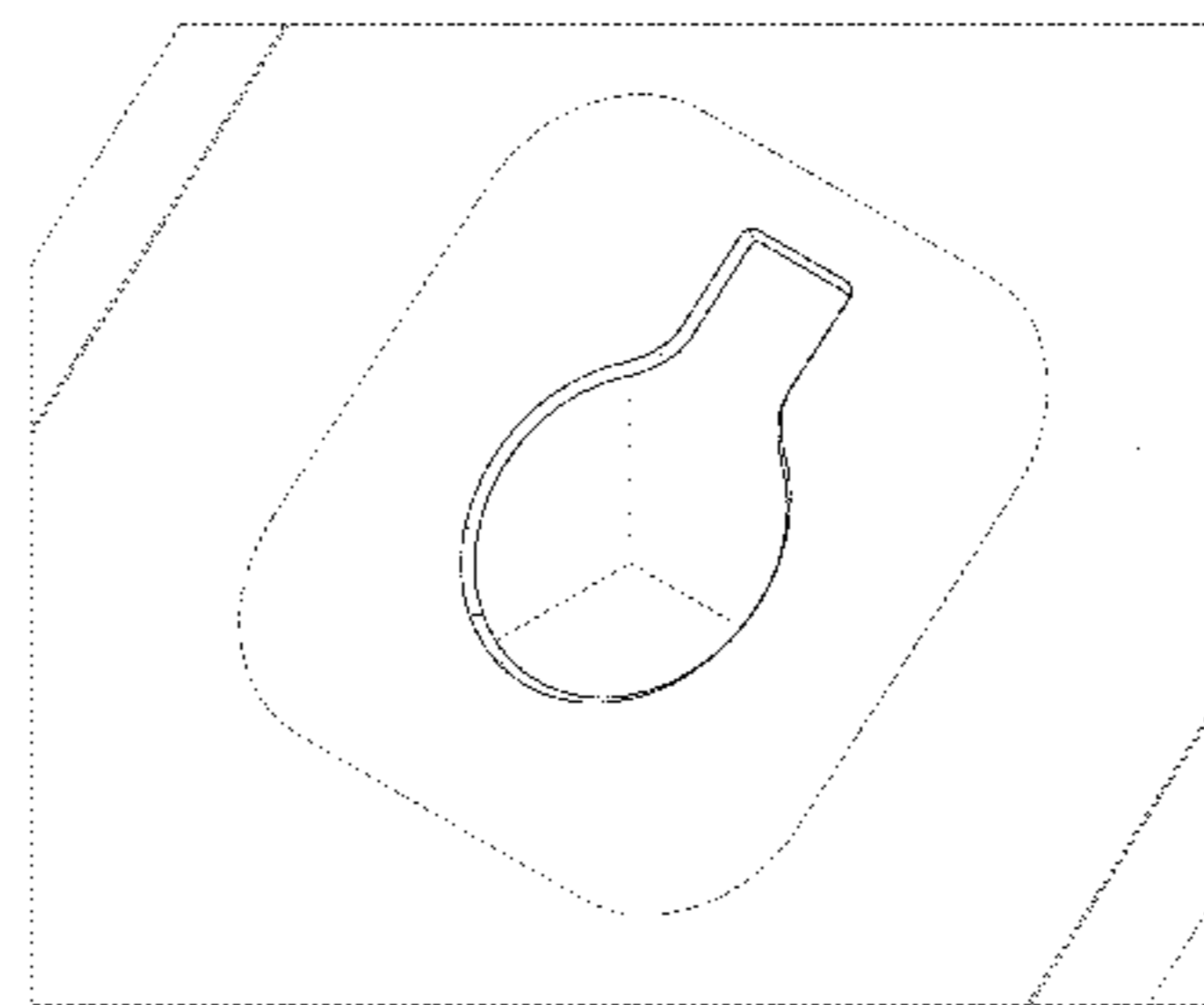
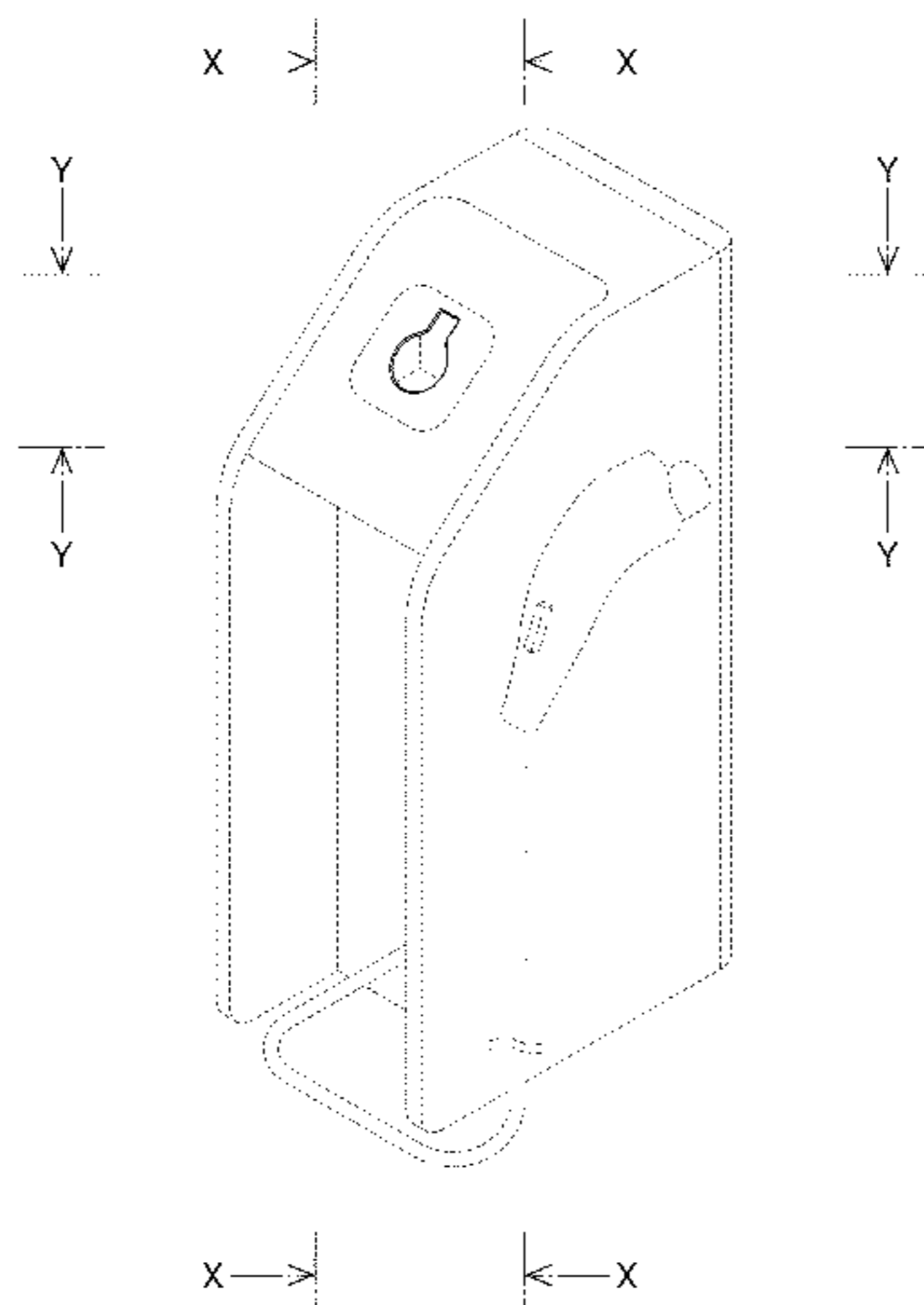

(56)

References Cited

U.S. PATENT DOCUMENTS

D345,296 S * 3/1994 Thomas D8/356
D397,983 S * 9/1998 Pingel et al. D12/217
D397,984 S * 9/1998 Pingel et al. D12/217
D404,006 S * 1/1999 Clowers et al. D13/107
D483,957 S * 12/2003 Skinner D6/302

D490,990 S * 6/2004 Li D6/310
D505,913 S * 6/2005 Kam Lun et al. D13/107
D517,478 S * 3/2006 Bayat et al. D13/108
D541,743 S * 5/2007 Virolainen et al. D13/110
D569,630 S * 5/2008 Bradford D6/310
D689,853 S * 9/2013 Smith D14/253
D698,309 S * 1/2014 Moribe et al. D13/107

* cited by examiner

FIG. 1

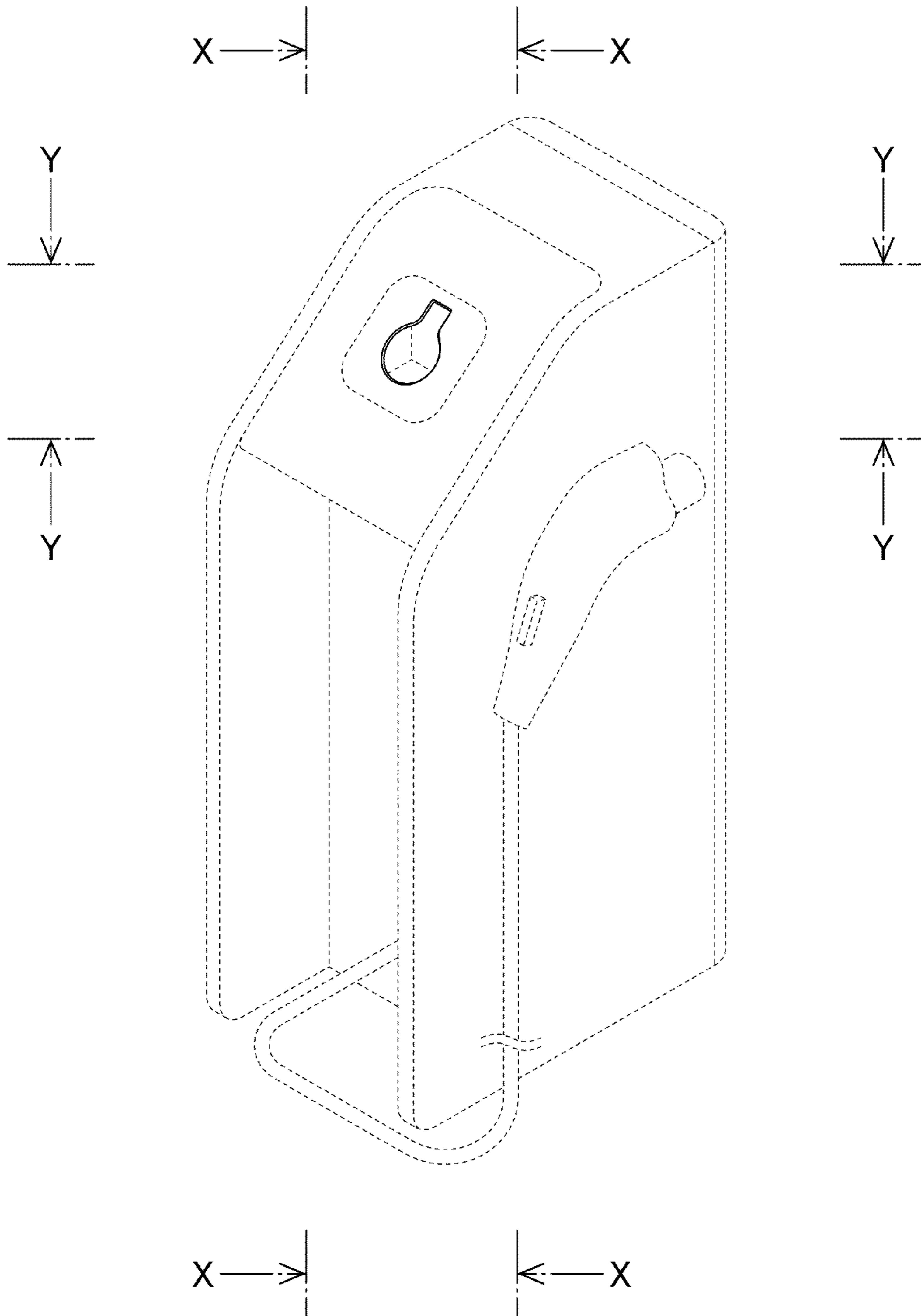

FIG. 2

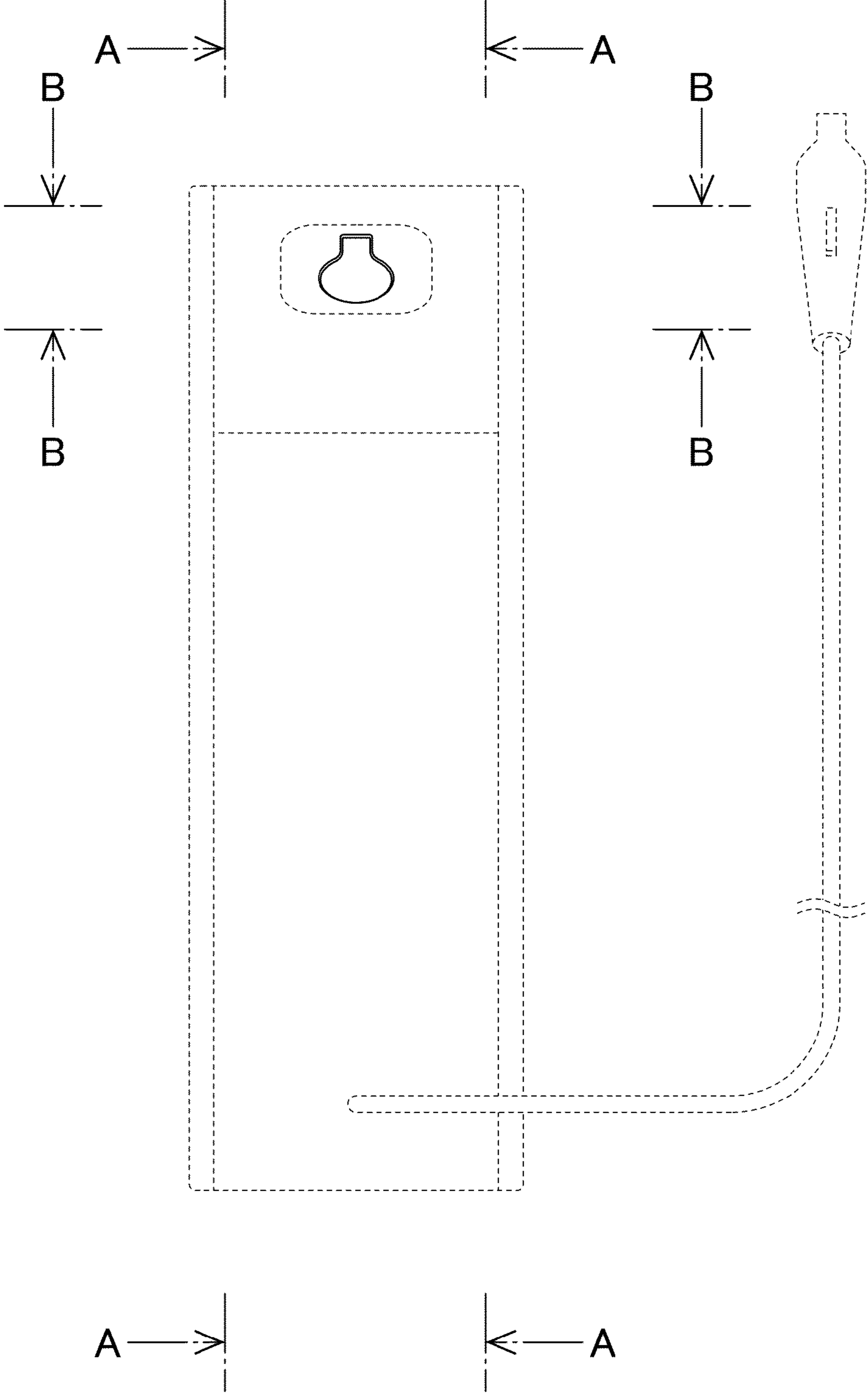

FIG. 3

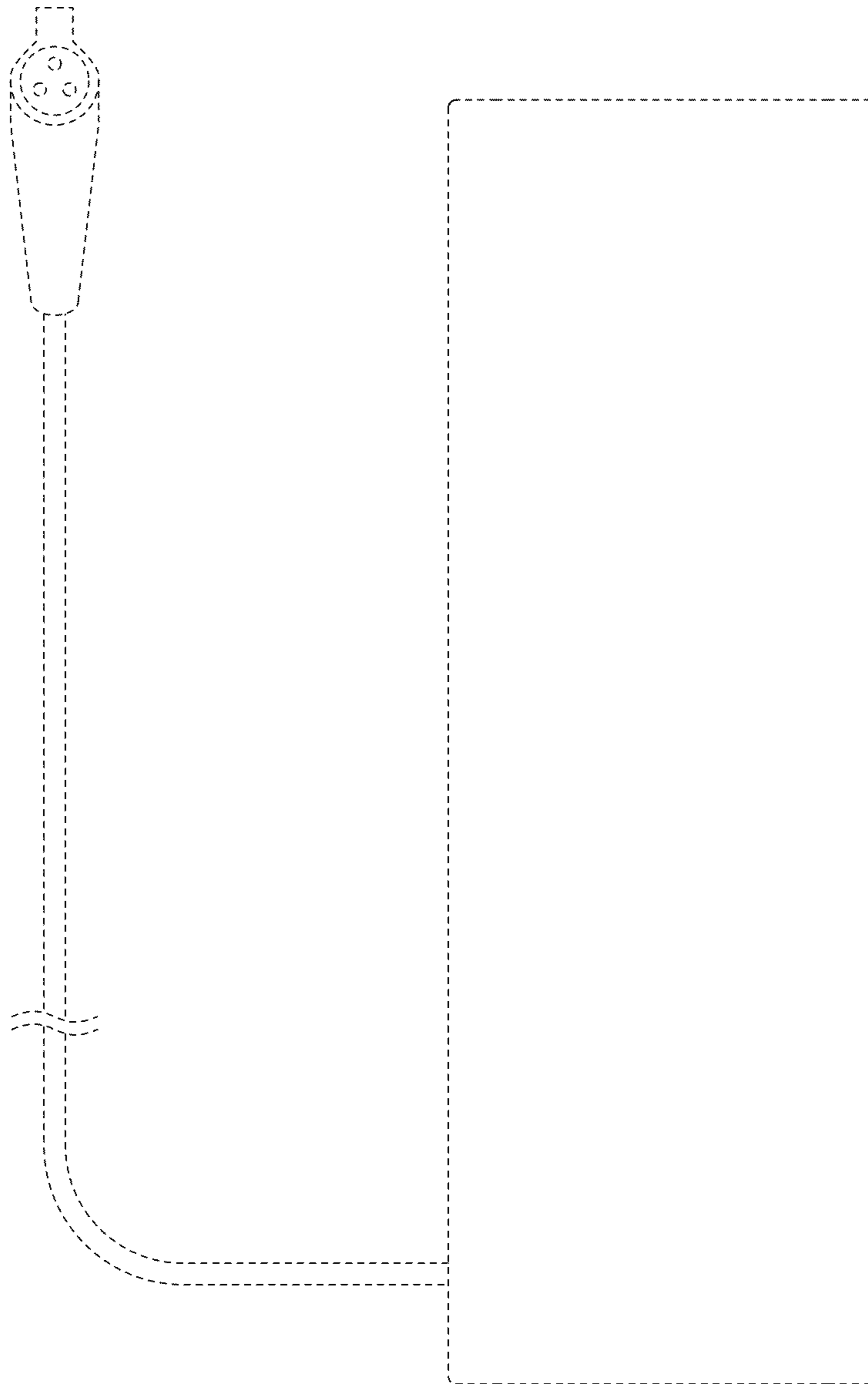

FIG. 4

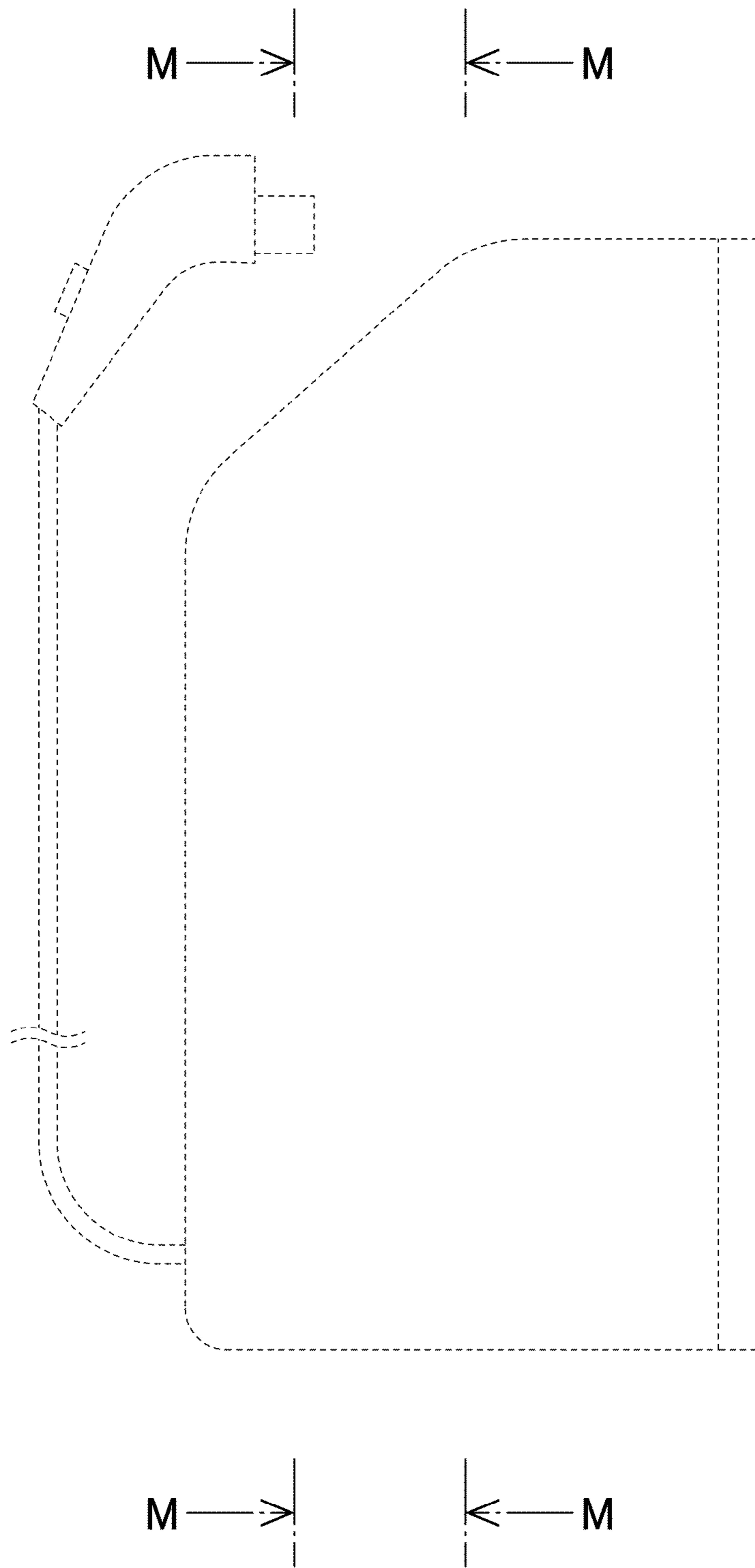

FIG. 5

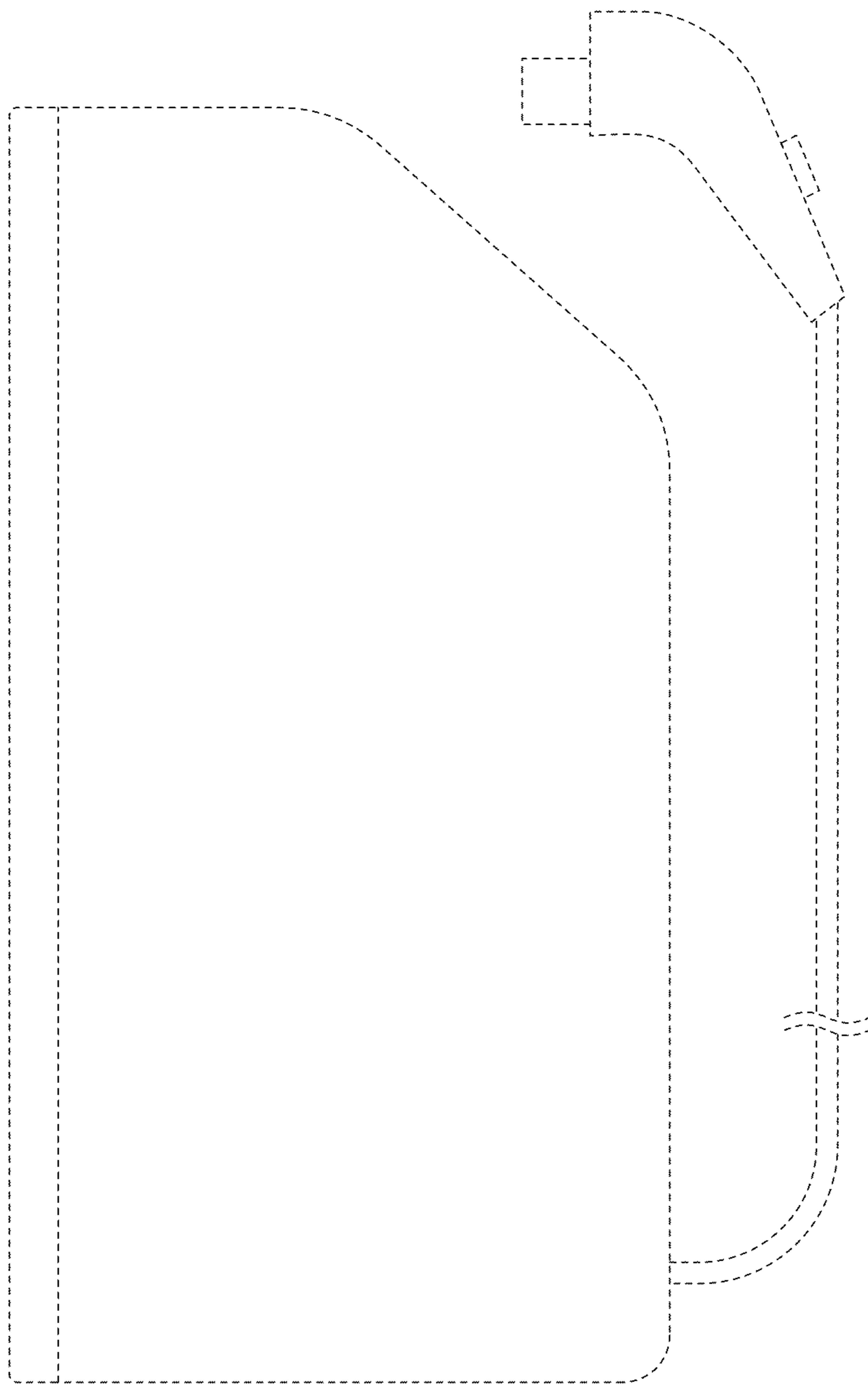

FIG. 6

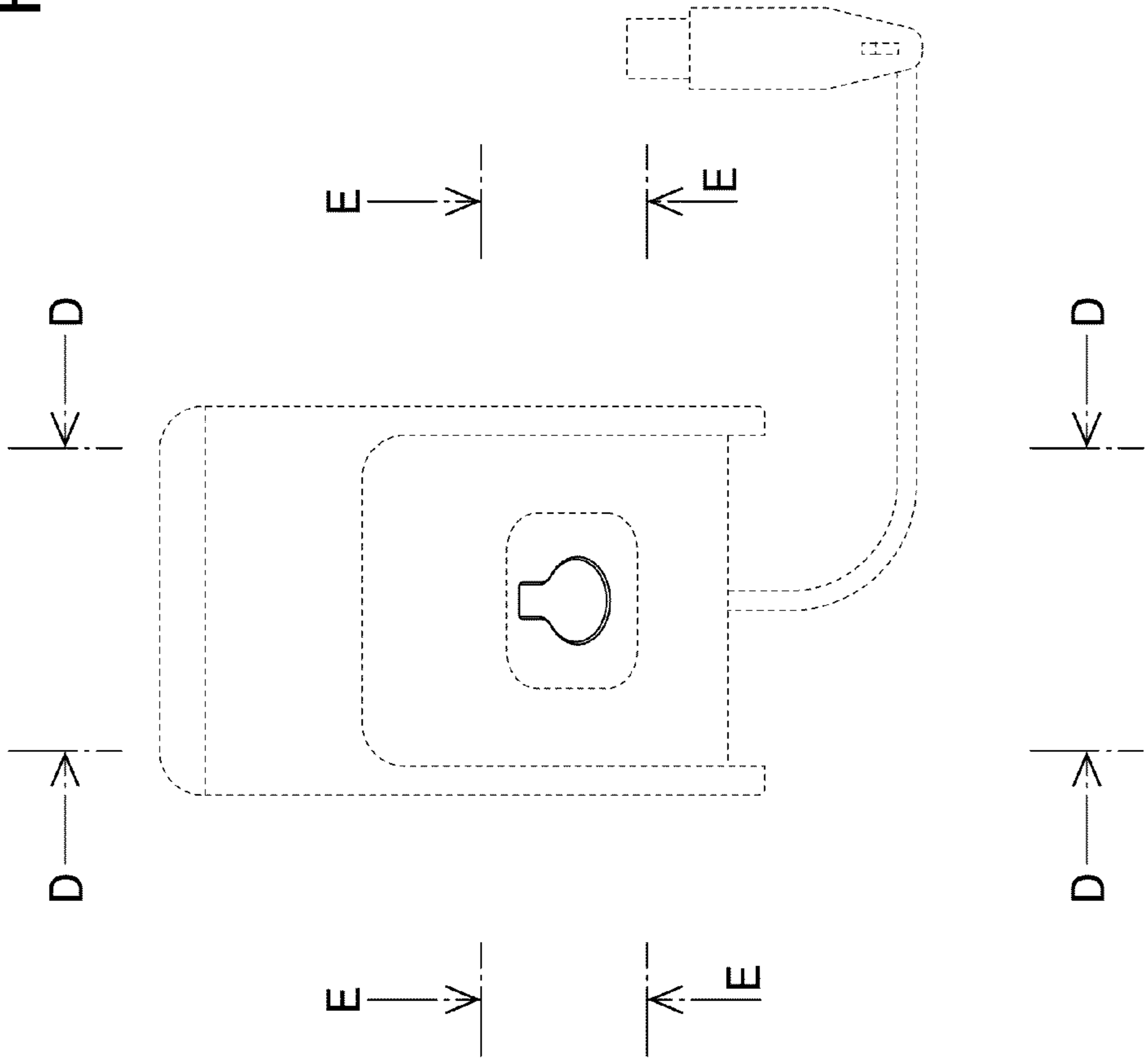

FIG. 7

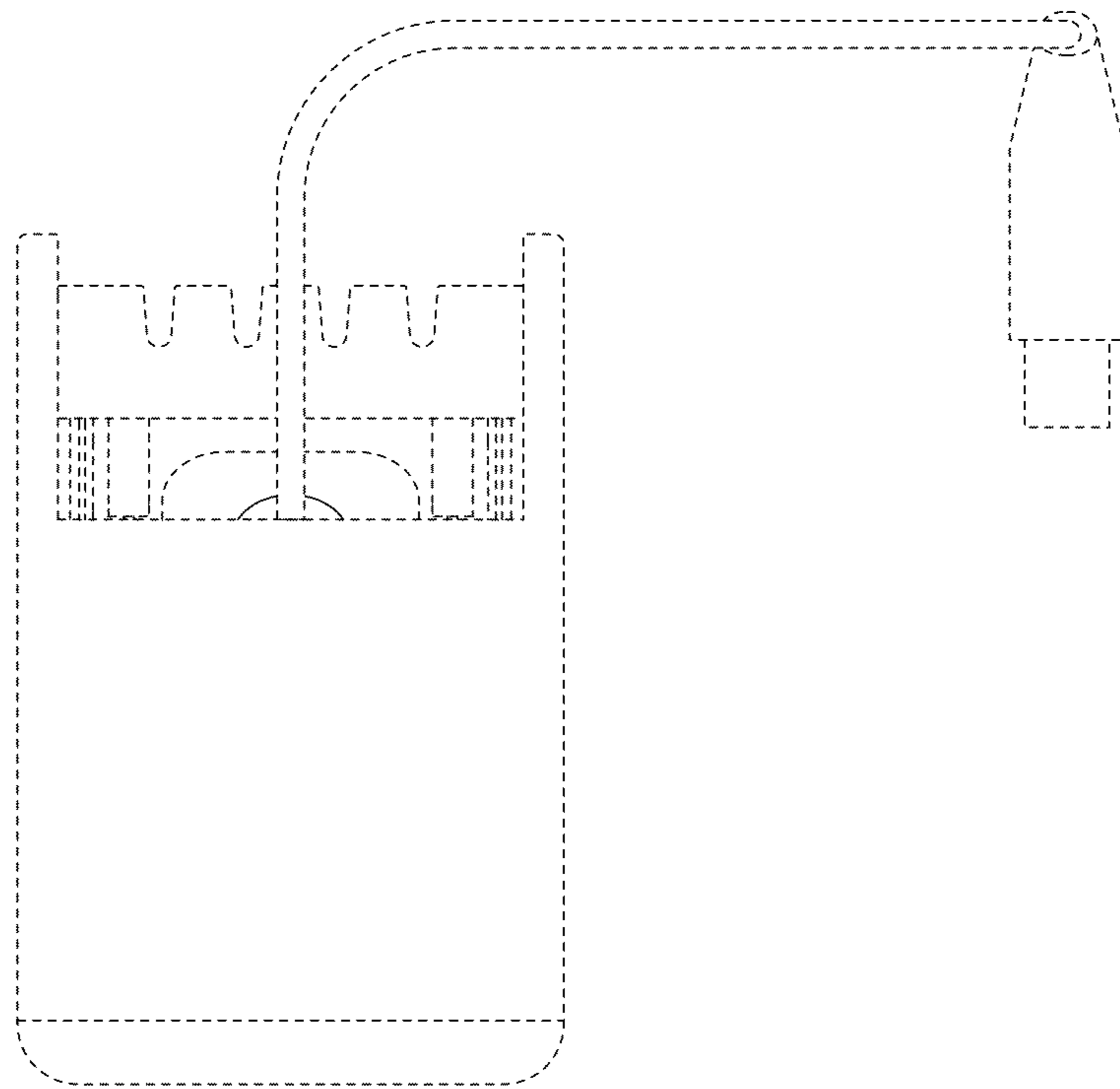

FIG. 8

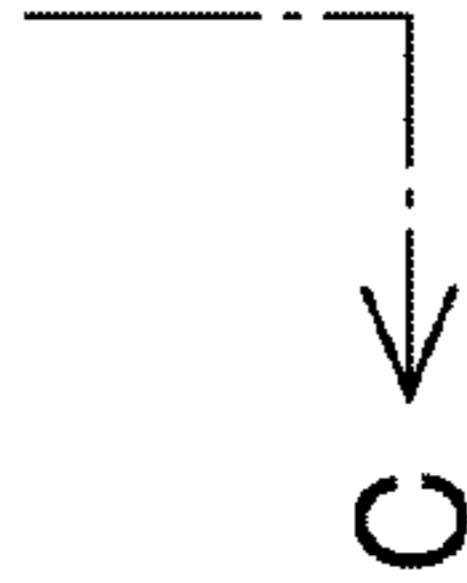
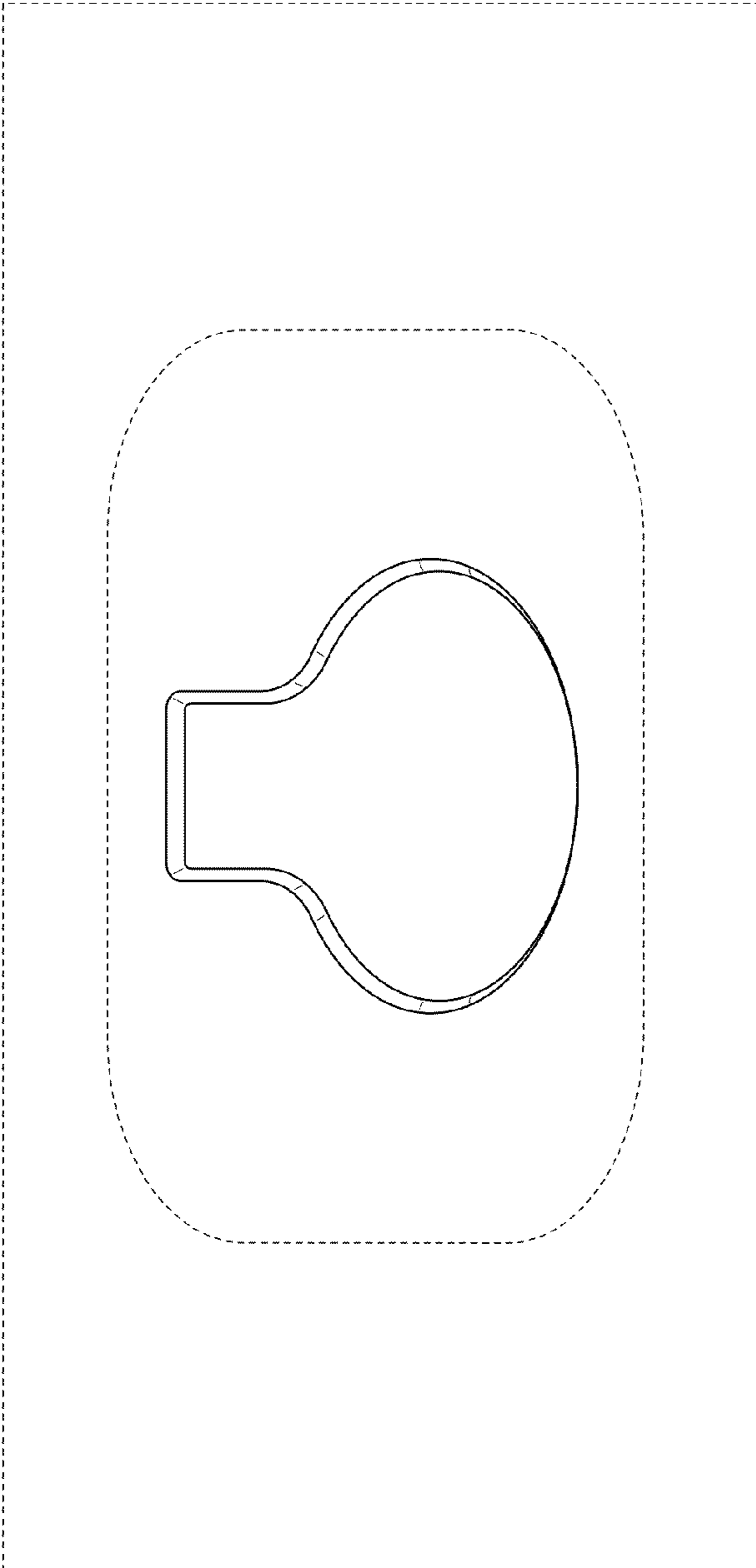
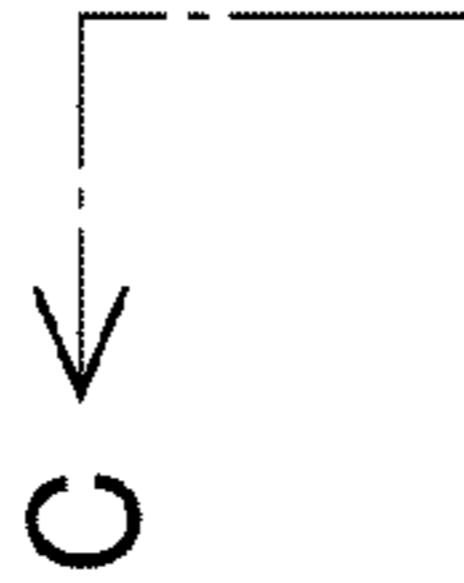

FIG. 9

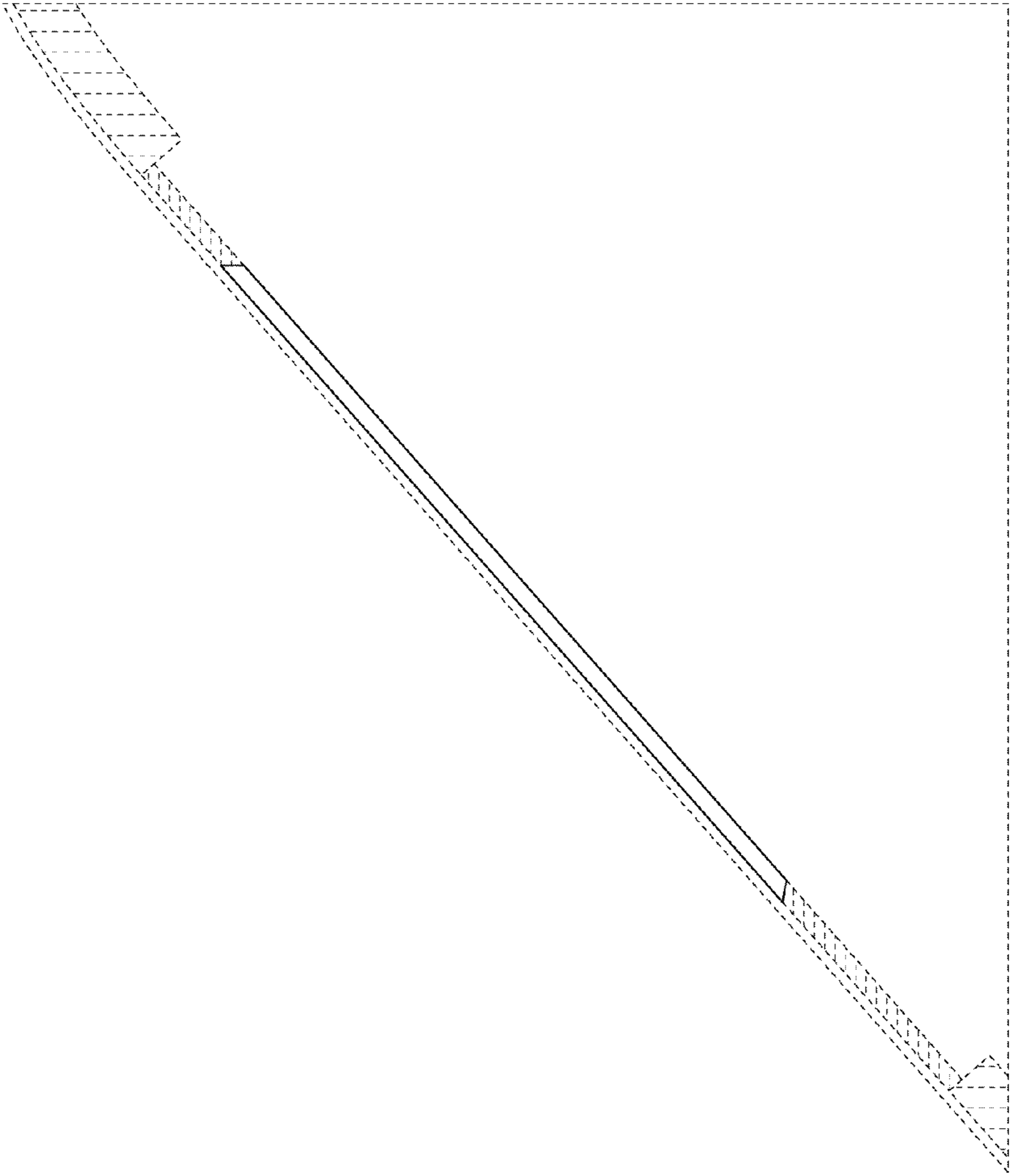

FIG. 10

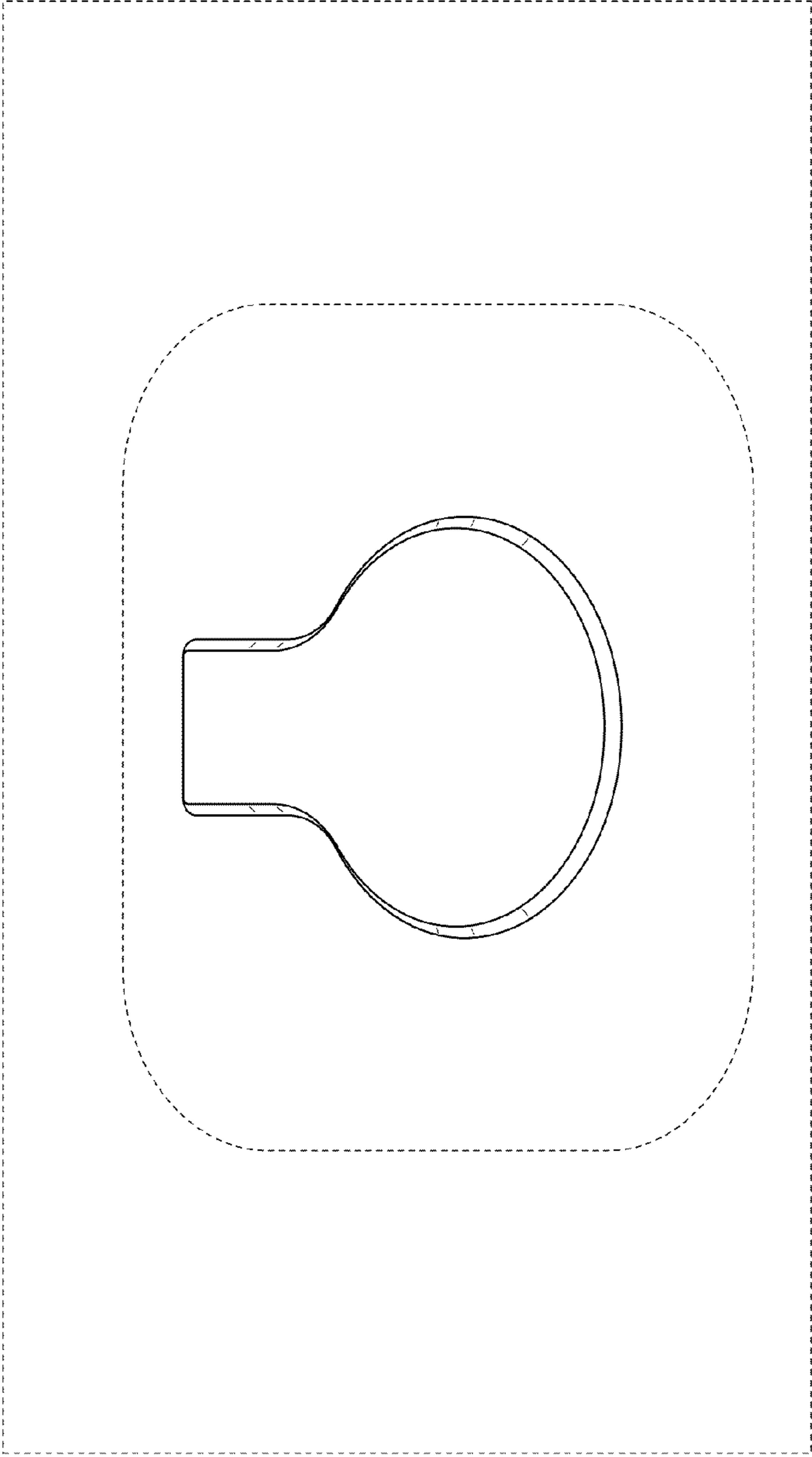

FIG.11

