



US00D732448S

(12) **United States Design Patent**
Yagisawa et al.

(10) **Patent No.:** **US D732,448 S**

(45) **Date of Patent:** **** Jun. 23, 2015**

(54) **INFORMATION DISPLAY UNIT FOR AN
AUTOMOTIVE VEHICLE**

(71) Applicant: **MITSUBISHI ELECTRIC
CORPORATION**, Tokyo (JP)

(72) Inventors: **Takaki Yagisawa**, Tokyo (JP); **Masami
Aikawa**, Tokyo (JP); **Hideo Imanaka**,
Tokyo (JP)

(73) Assignee: **Mitsubishi Electric Corporation**,
Tokyo (JP)

(**) Term: **14 Years**

(21) Appl. No.: **29/490,601**

(22) Filed: **May 12, 2014**

(30) **Foreign Application Priority Data**

Nov. 18, 2013 (JP) 2013-026948

(51) **LOC (10) Cl.** **12-16**

(52) **U.S. Cl.**
USPC **D12/192**

(58) **Field of Classification Search**
USPC D12/192, 415, 110, 114; 180/90;
280/750-752; 296/190.01-190.09,
296/191, 70; D15/17, 28; D10/46, 98,
D10/102-103, 122-127
See application file for complete search history.

(56) **References Cited**

U.S. PATENT DOCUMENTS

D100,173 S * 6/1936 Mayer D12/192
D131,595 S * 3/1942 Ward D12/192

D652,773 S * 1/2012 Kitajima et al. D12/192
D653,185 S * 1/2012 Senda et al. D12/192
D654,004 S * 2/2012 Hamajima et al. D12/192
D654,837 S * 2/2012 Riggs et al. D12/192
D656,074 S * 3/2012 Ohmori et al. D12/192

* cited by examiner

Primary Examiner — Katarina A Betton

(74) *Attorney, Agent, or Firm* — Studebaker & Brackett PC

(57) **CLAIM**

The ornamental design for an information display unit for an automotive vehicle, as shown and described.

DESCRIPTION

FIG. 1 is a front, top and right side perspective view of an information display unit for an automotive vehicle, showing our new design;

FIG. 2 is a front elevational view thereof;

FIG. 3 is a rear elevational view thereof;

FIG. 4 is a left side elevational view thereof;

FIG. 5 is a right side elevational view thereof;

FIG. 6 is a top plan view thereof;

FIG. 7 is a bottom plan view thereof;

FIG. 8 is an enlarged cross-sectional view thereof; taken along line 8-8 of FIG. 2;

FIG. 9 is a front elevational reference view which is in condition to have put away this article during stopping;

FIG. 10 is a front elevational reference view which is in condition to have lowered this article for urban area travels; and,

FIG. 11 is a front elevational reference view which is in condition to have lowered this article for high-speed runs.

The broken lines in all views are shown for illustrative purposes only and form no part of the claimed design.

1 Claim, 10 Drawing Sheets

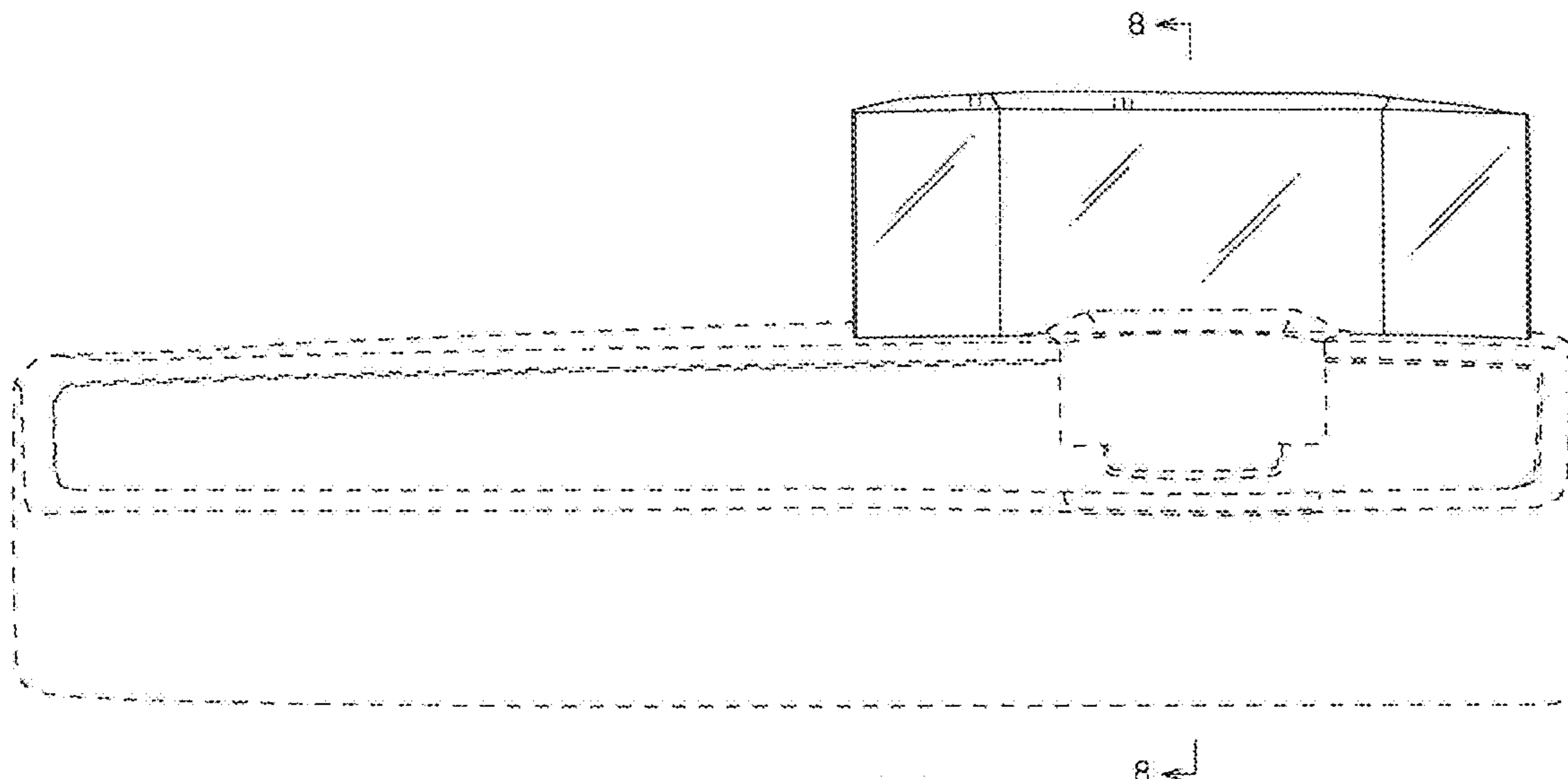

Fig. 1

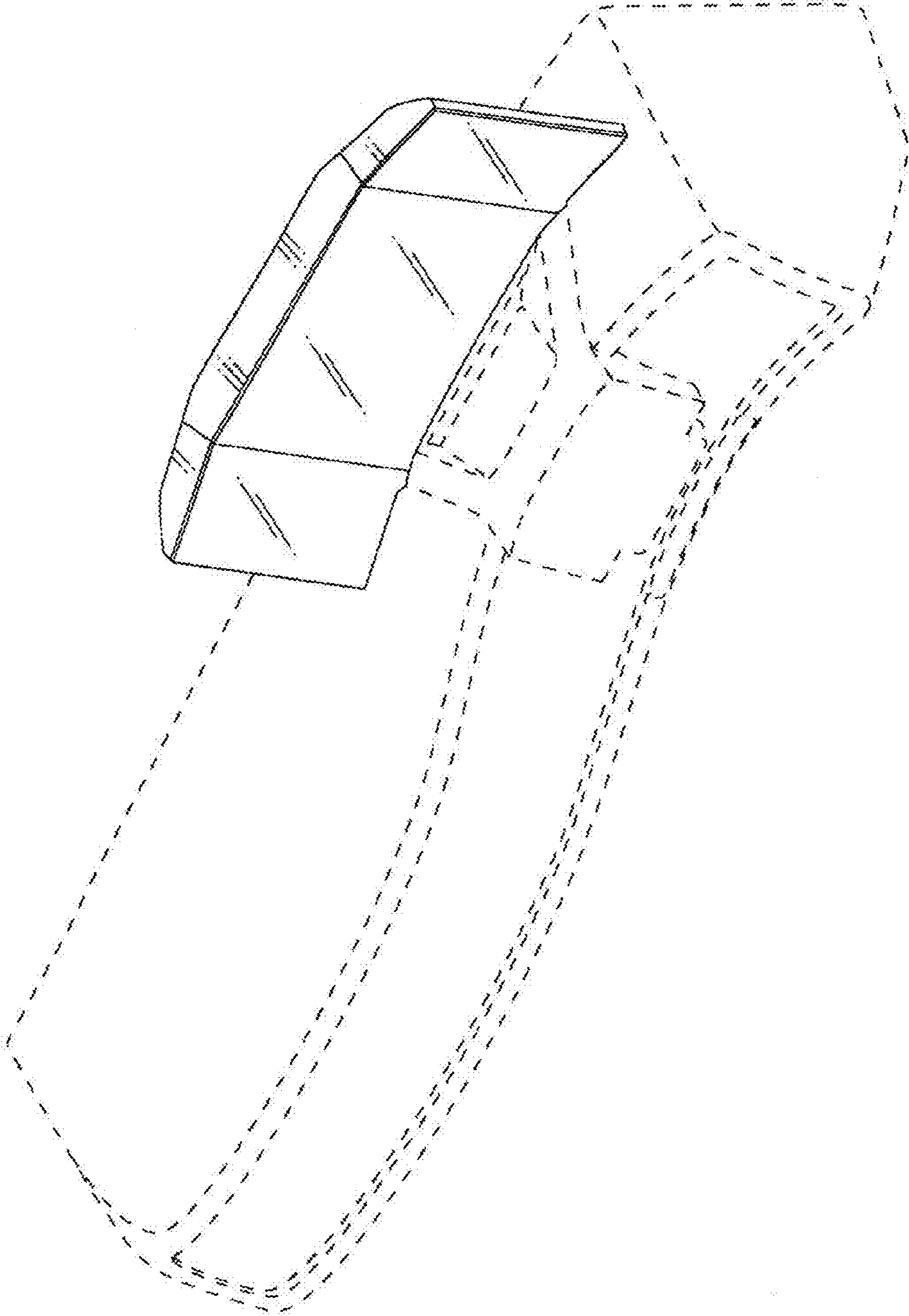

Fig. 2

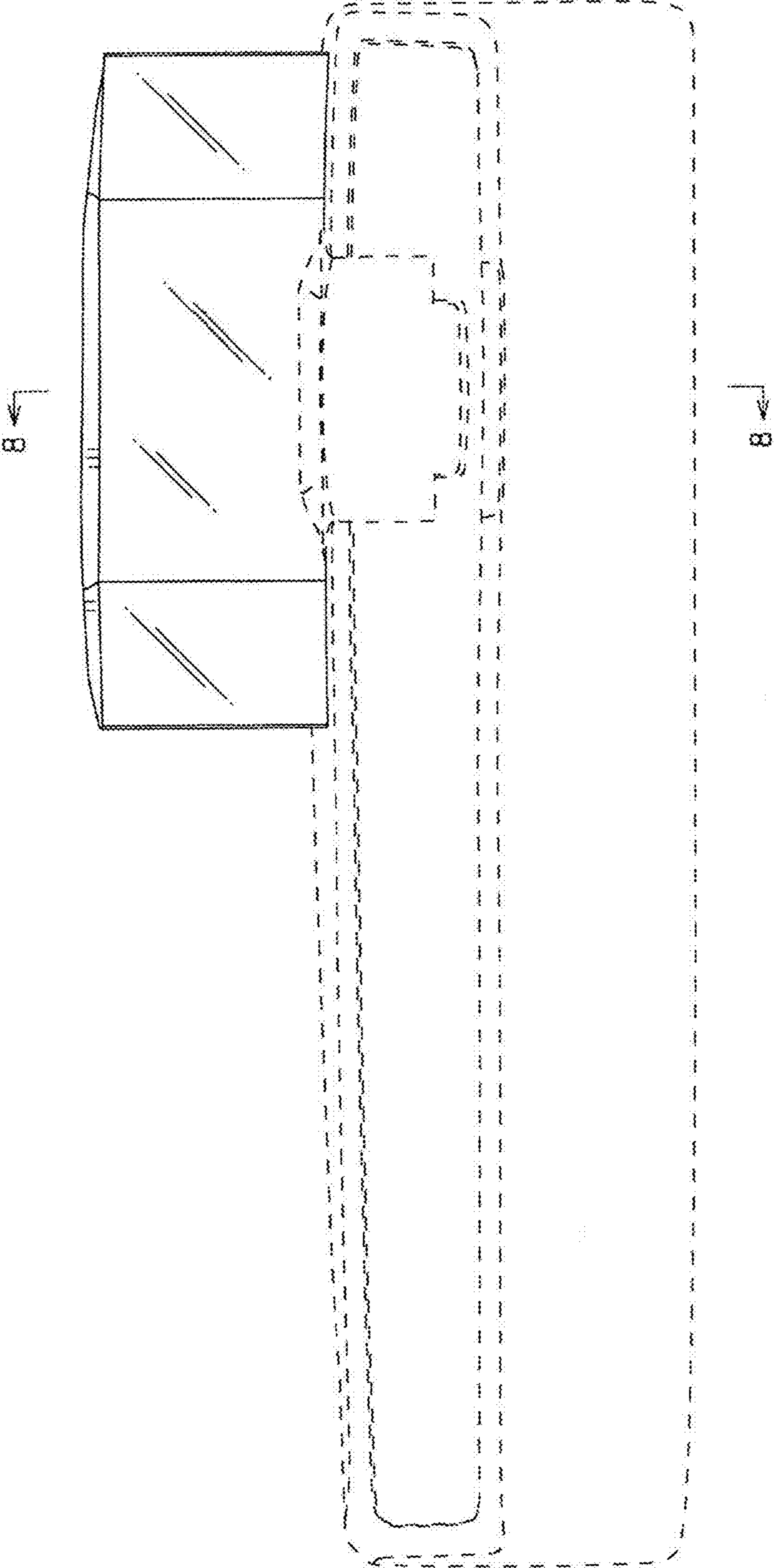

Fig. 3

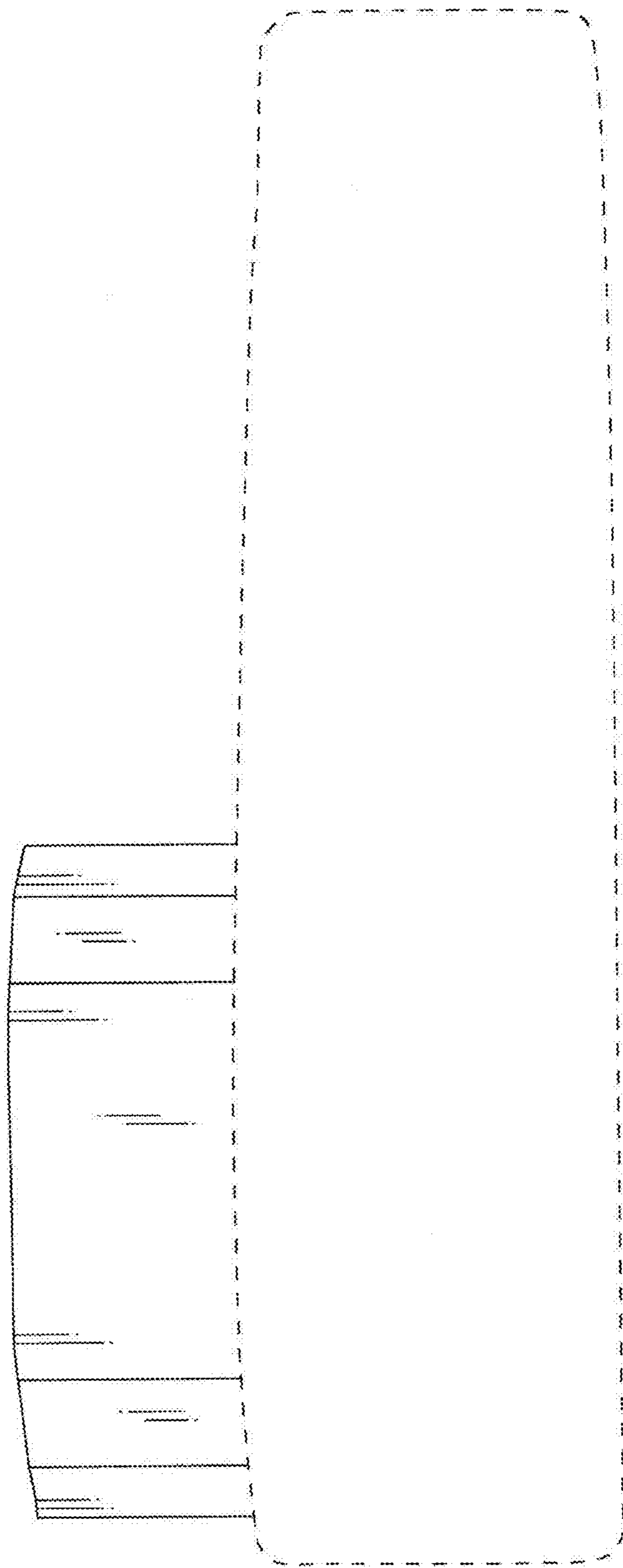

Fig. 5

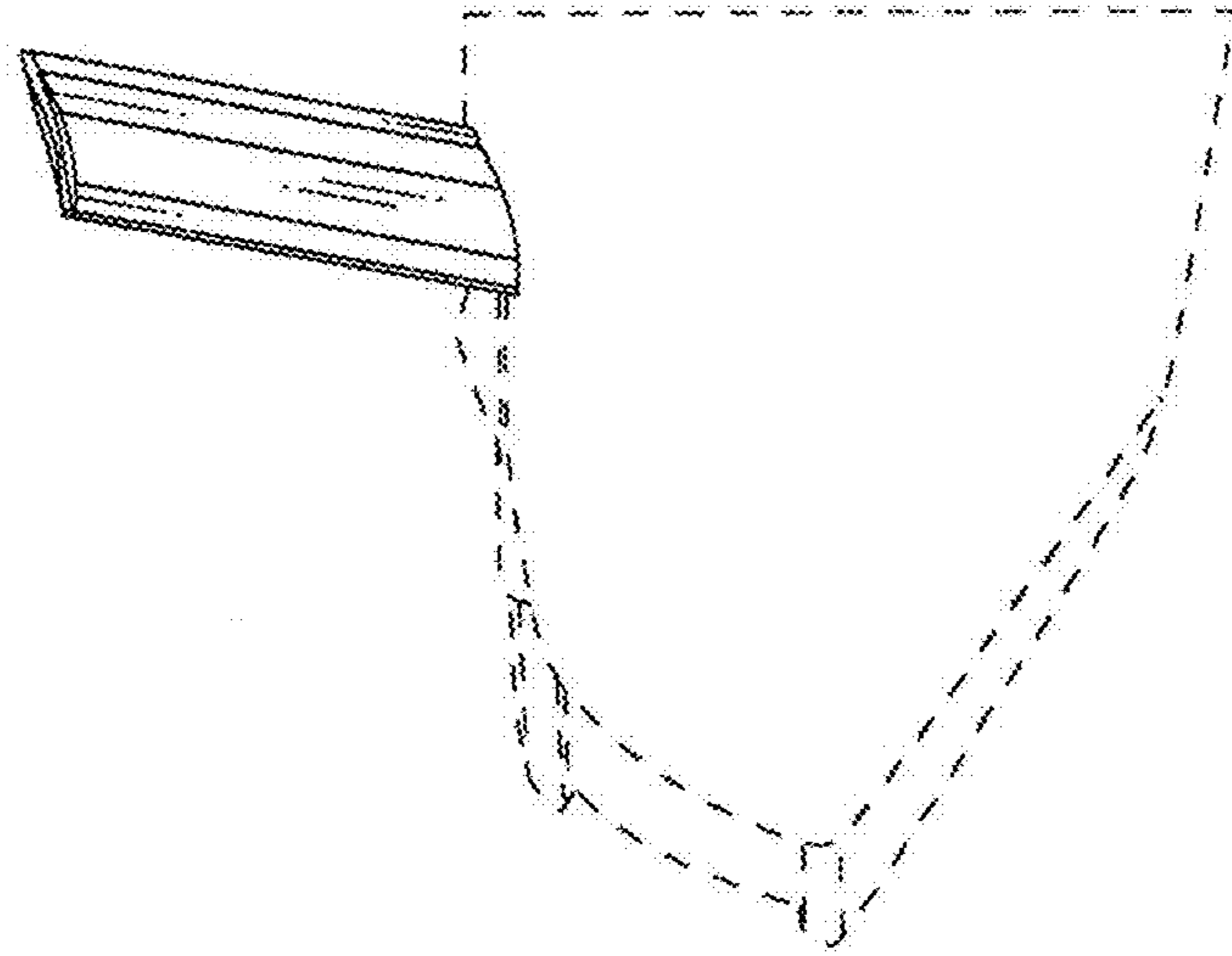

Fig. 4

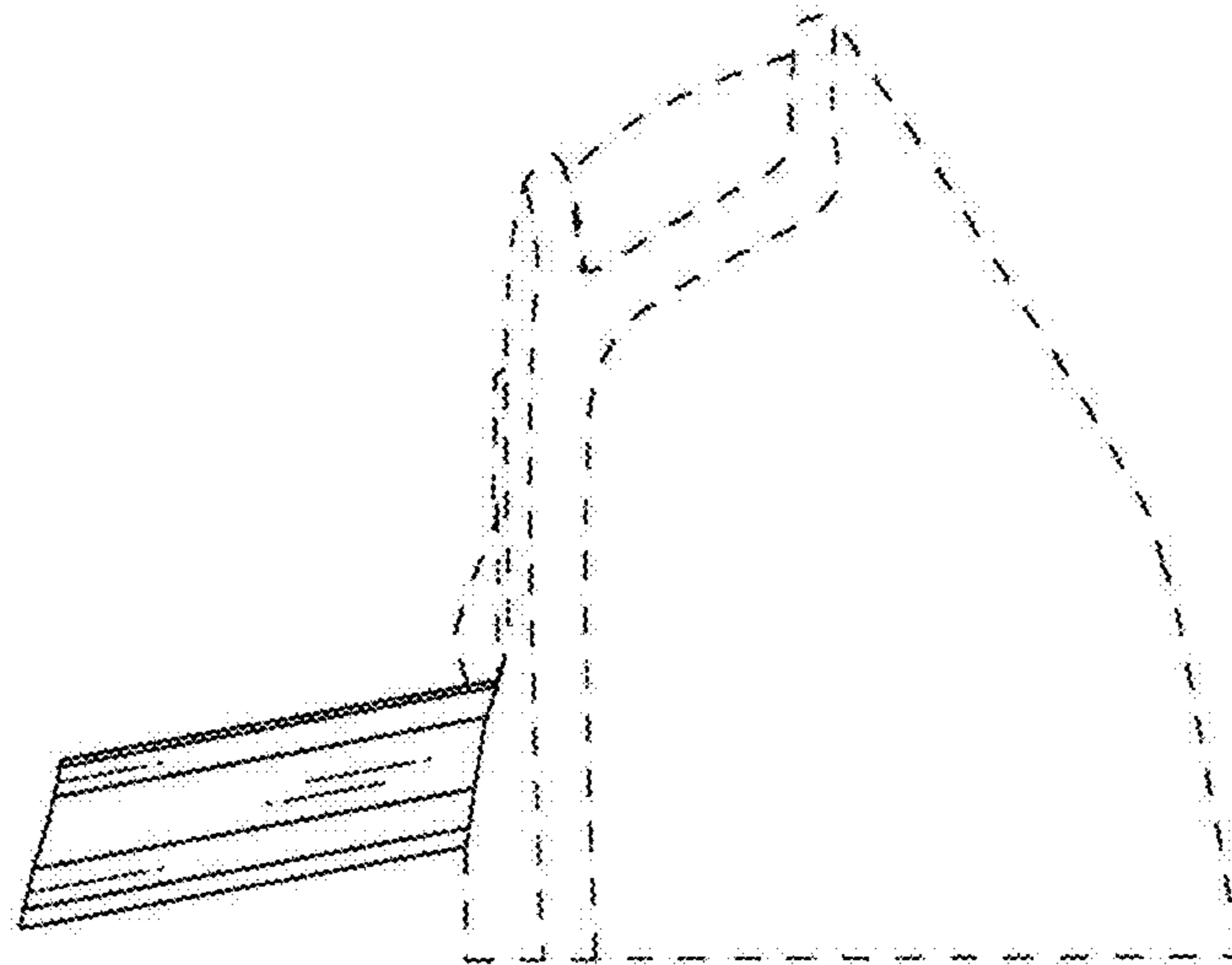

Fig. 6

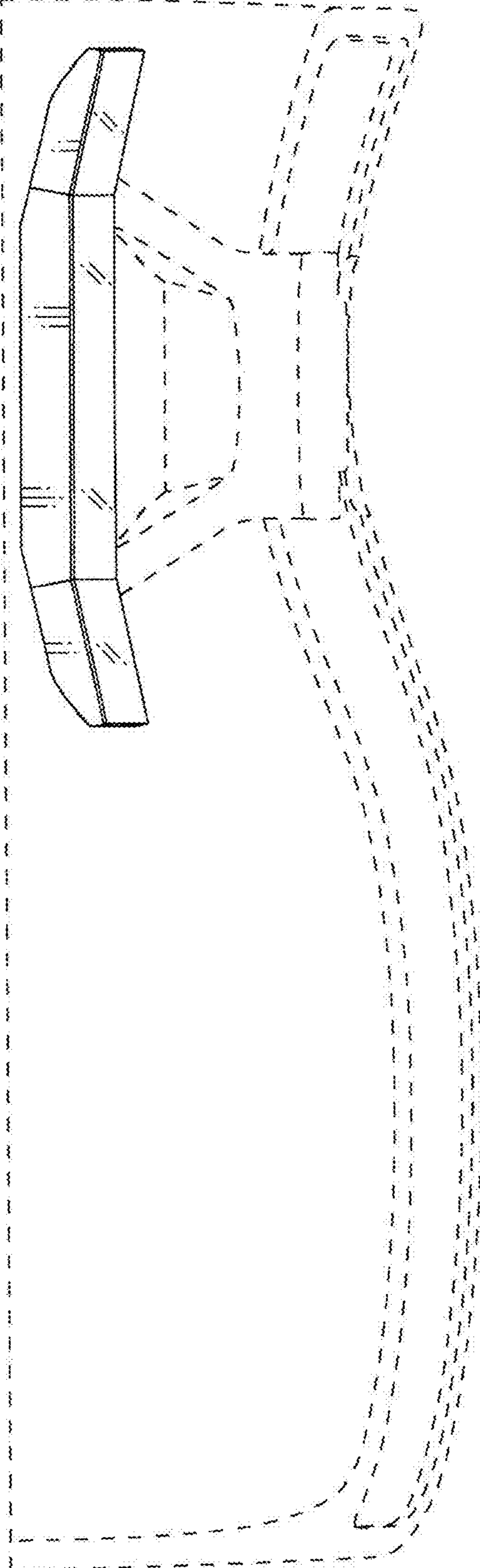

Fig. 7

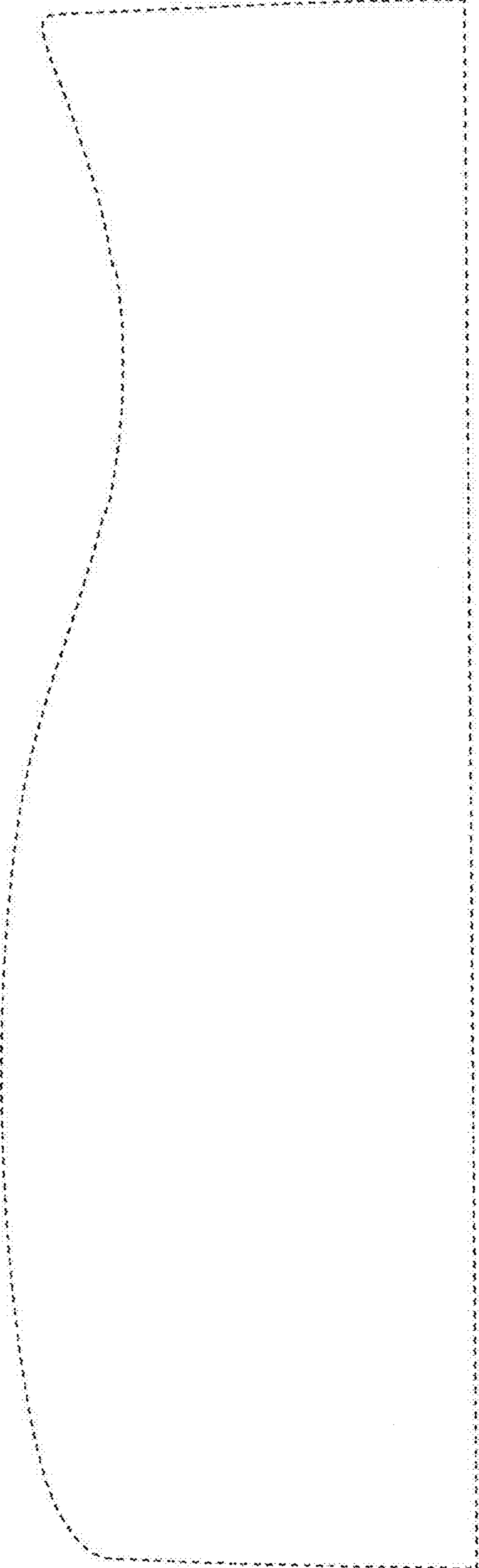

Fig. 8

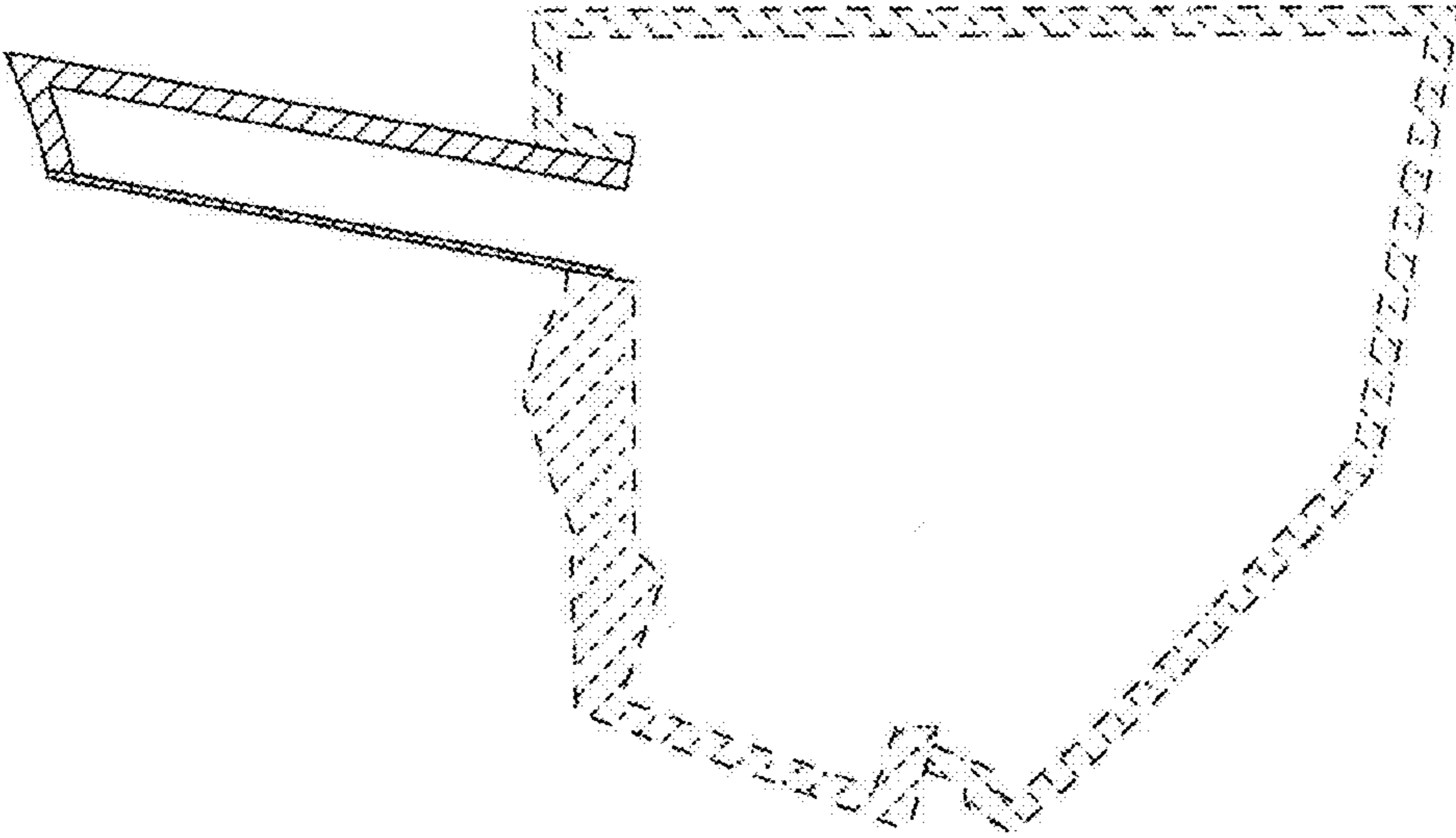

Fig. 9

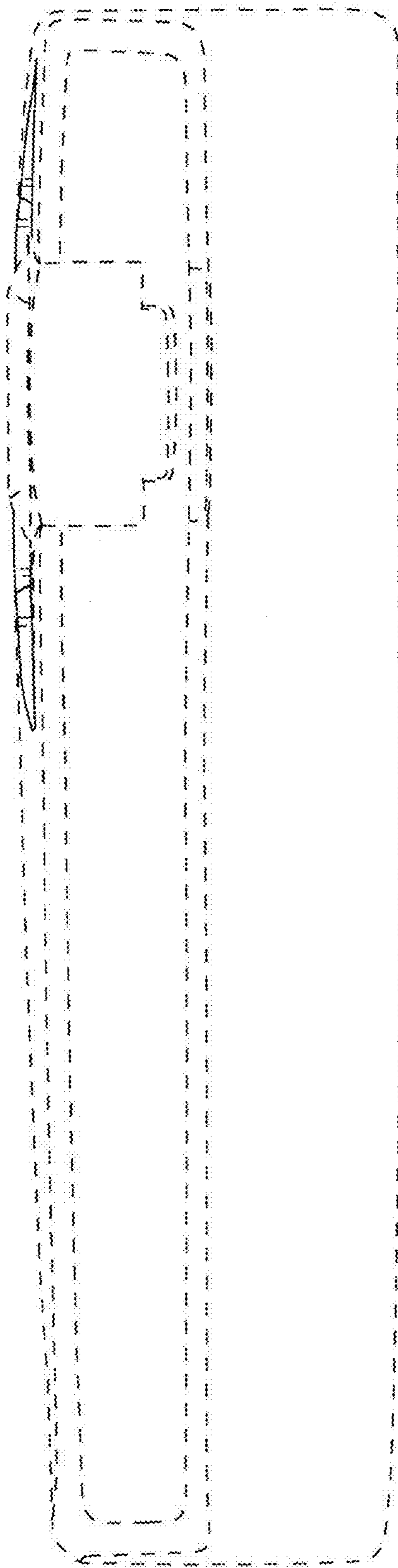

Fig. 10

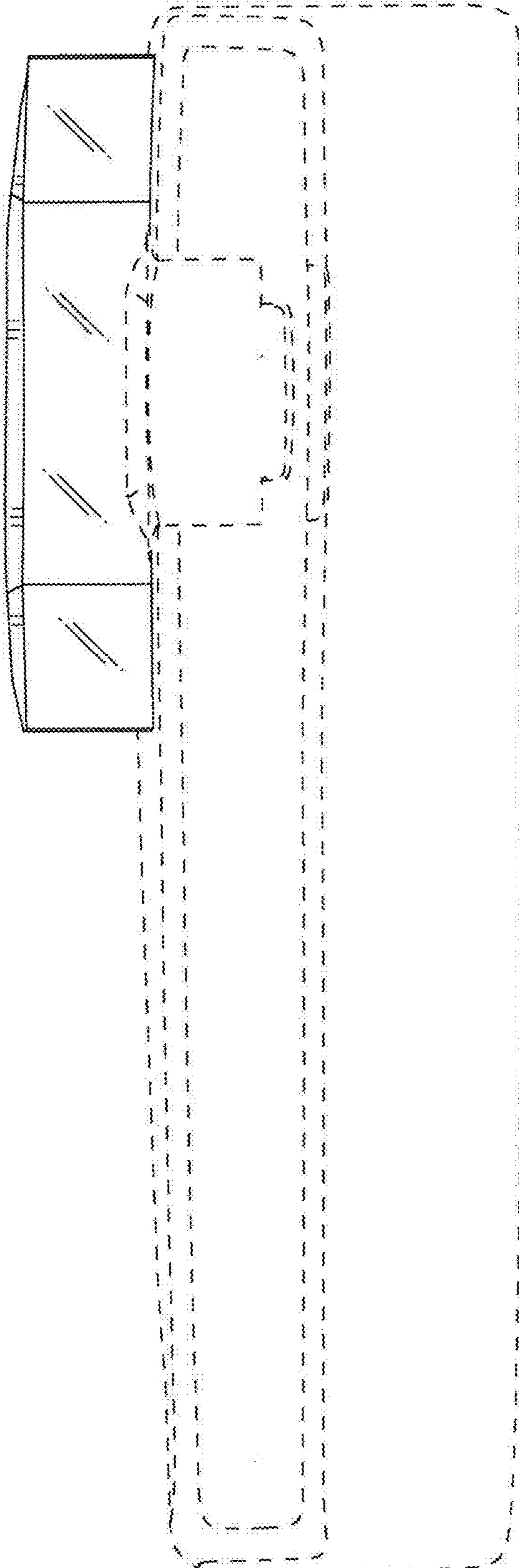

Fig. 11

