

US00D731949S

(12) **United States Design Patent**
Matsuo

(10) **Patent No.:** **US D731,949 S**
(45) **Date of Patent:** **** Jun. 16, 2015**

(54) **AIRPLANE**
(71) Applicant: **Edson Matsuo**, Porto Alegre (BR)
(72) Inventor: **Edson Matsuo**, Porto Alegre (BR)
(73) Assignee: **GRENDENE S.A.** (BR)

3,109,614 A * 11/1963 Steidl 244/87
D359,472 S * 6/1995 Day D12/343
D386,143 S * 11/1997 Astaire D12/345
D505,204 S * 5/2005 Eatkins et al. D12/345
D644,165 S * 8/2011 Fujino et al. D12/345
D674,734 S * 1/2013 Fujino et al. D12/345
2009/0159751 A1 * 6/2009 Wittmer et al. 244/134 E
2012/0138736 A1 * 6/2012 Cazals et al. 244/54

(**) Term: **14 Years**

* cited by examiner

(21) Appl. No.: **29/478,452**

Primary Examiner — Martie K Holtje

(22) Filed: **Jan. 6, 2014**

(74) *Attorney, Agent, or Firm* — Ostrolenk Faber LLP

(30) **Foreign Application Priority Data**

(57) **CLAIM**

The ornamental design for an airplane, as shown and described.

Jul. 4, 2013 (BR) 30 2013 003266 3

DESCRIPTION

(51) **LOC (10) Cl.** **12-07**

FIG. 1 is a right side, top, front, perspective view of an airplane showing my new design;
FIG. 2 is a left side view thereof;
FIG. 3 is a right side view thereof;
FIG. 4 is a top view thereof;
FIG. 5 is a bottom view thereof;
FIG. 6 is a front view thereof; and,
FIG. 7 is a rear view thereof.

(52) **U.S. Cl.**

USPC **D12/319**; D12/343; D12/345

(58) **Field of Classification Search**

USPC D12/319–345

CPC B64C 1/00; B64C 1/068; B64C 1/26;

B64C 2001/0045; B64C 2001/0054; B64C

5/02; B64C 5/06; B64D 27/00; B64D 27/02;

B64D 27/16; B64D 27/20; B64D 29/04;

Y02T 50/12; Y02T 50/44

See application file for complete search history.

The characteristic feature of the design is the surface ornamentation on the fuselage, jet engine, and tail of the airplane. The stippling represents a contrasting appearance that contrasts with the remainder of the airplane.

(56) **References Cited**

The characteristic feature of the design is the surface ornamentation on the fuselage, jet and tail of the airplane. The stippling illustrates a color contrasting with the color of the remainder of the airplane.

U.S. PATENT DOCUMENTS

D172,880 S * 8/1954 Johnson et al. D12/342

D173,032 S * 9/1954 Johnson et a. D12/342

D177,327 S * 4/1956 Holtby et al. D12/342

1 Claim, 4 Drawing Sheets

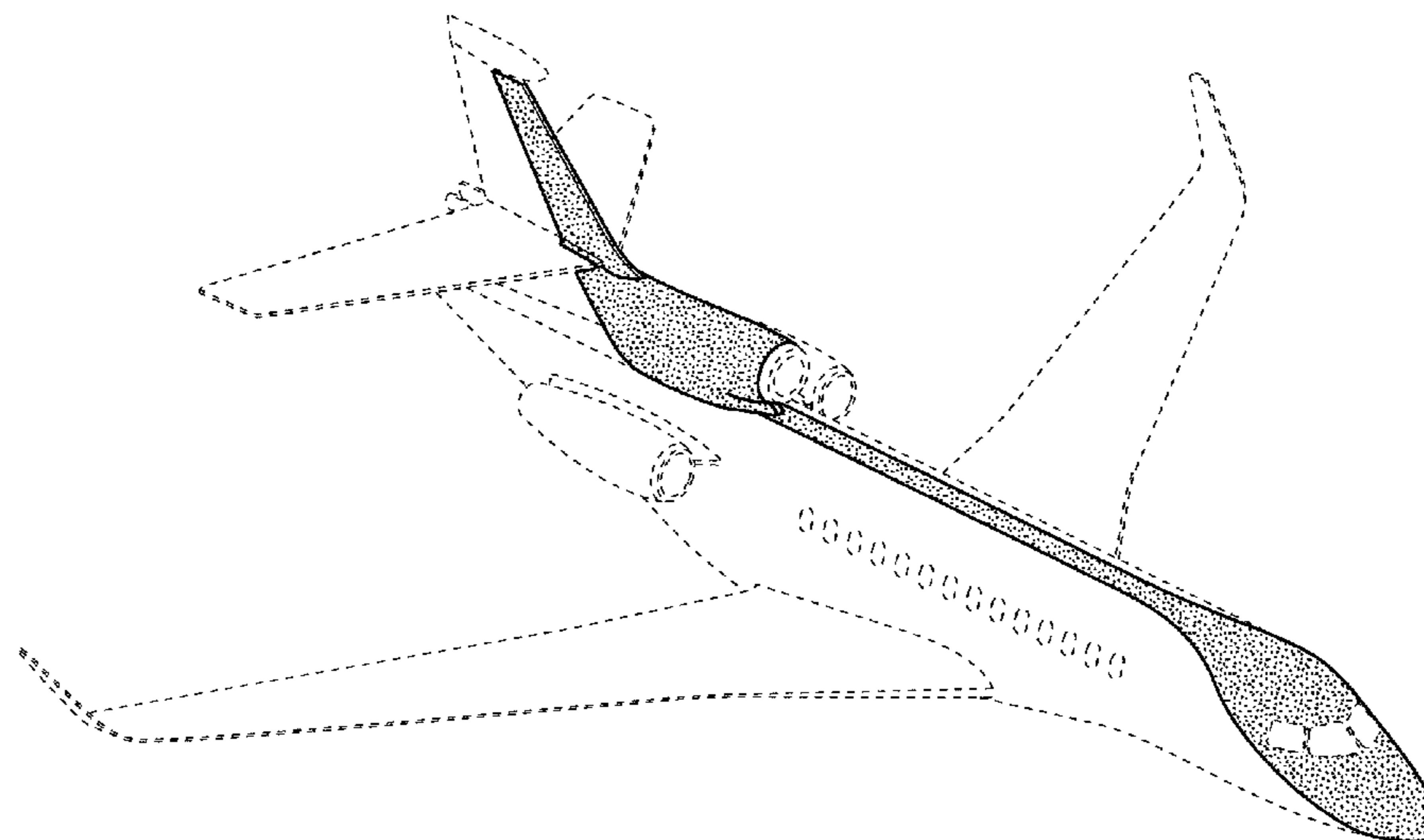

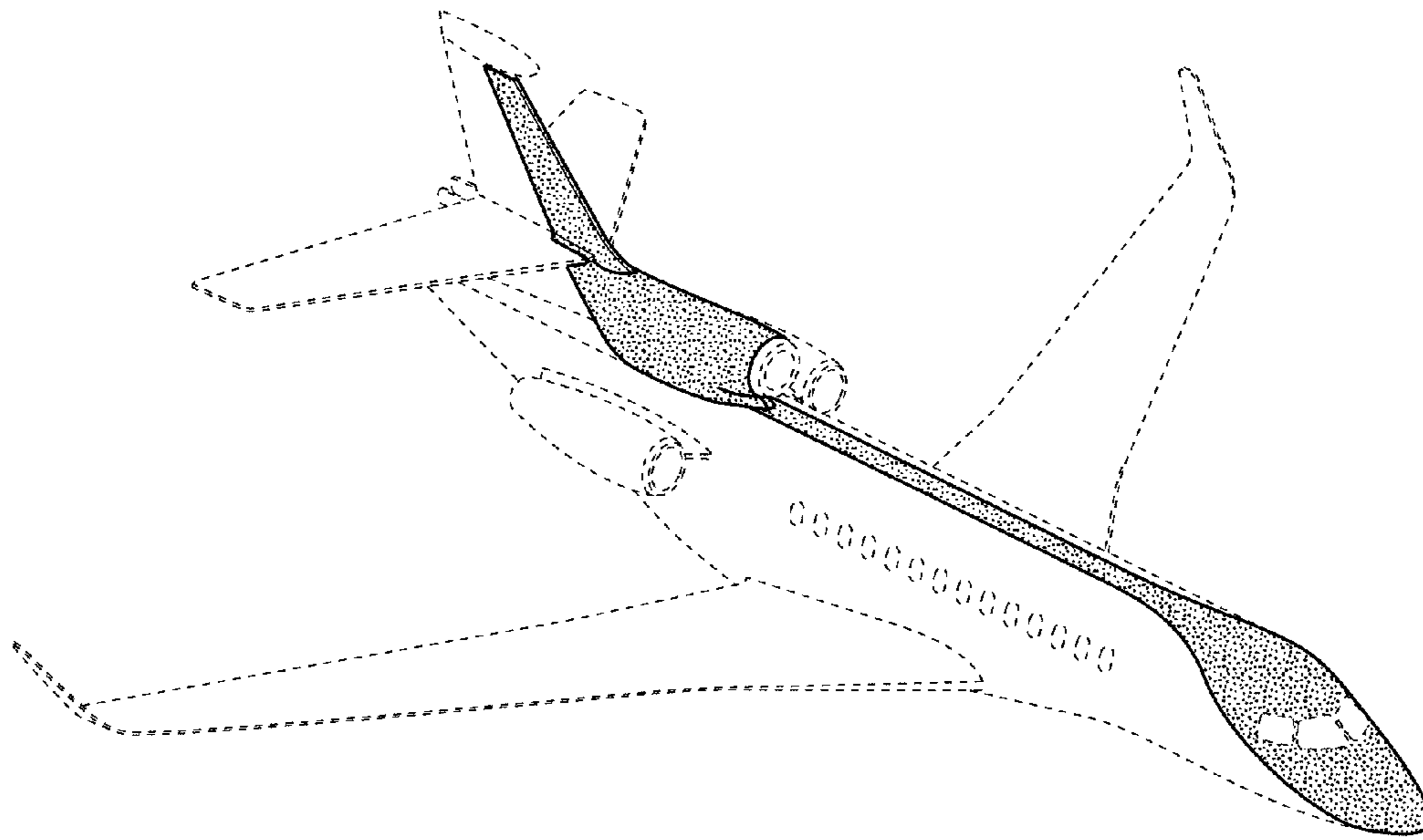

FIG. 1

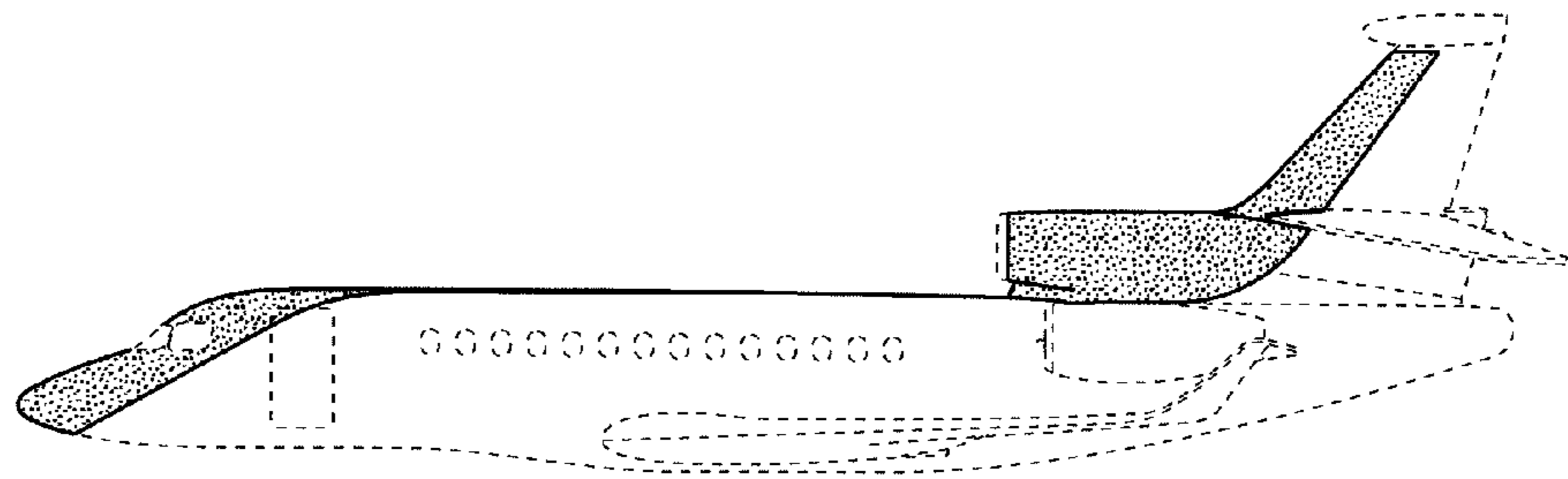

FIG. 2

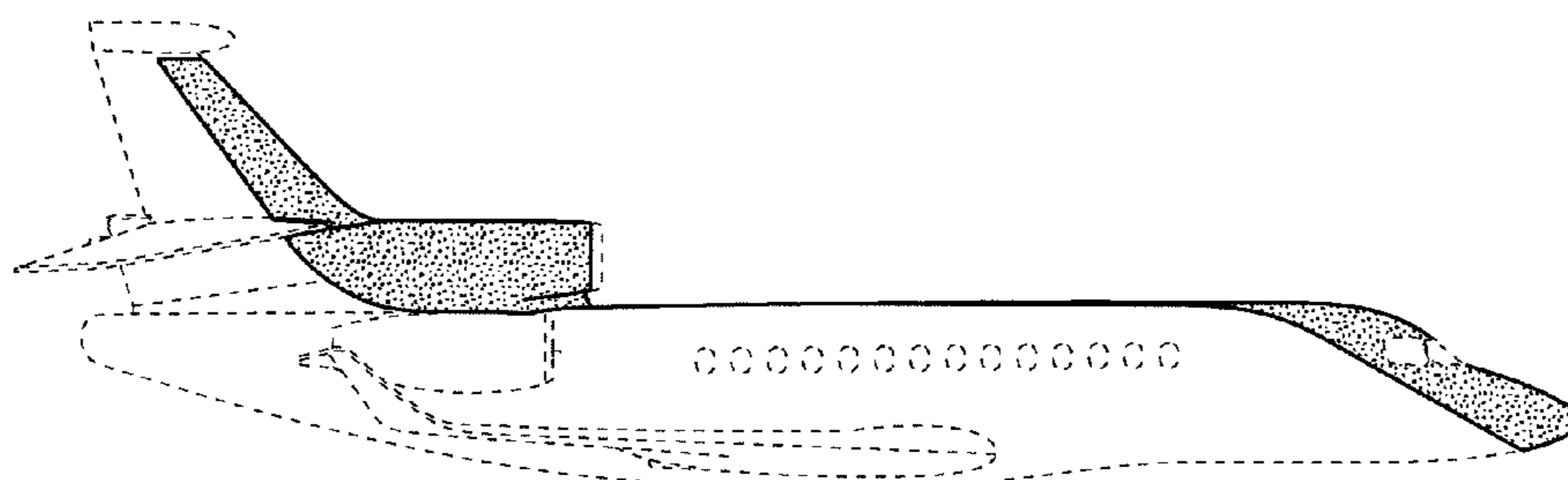

FIG. 3

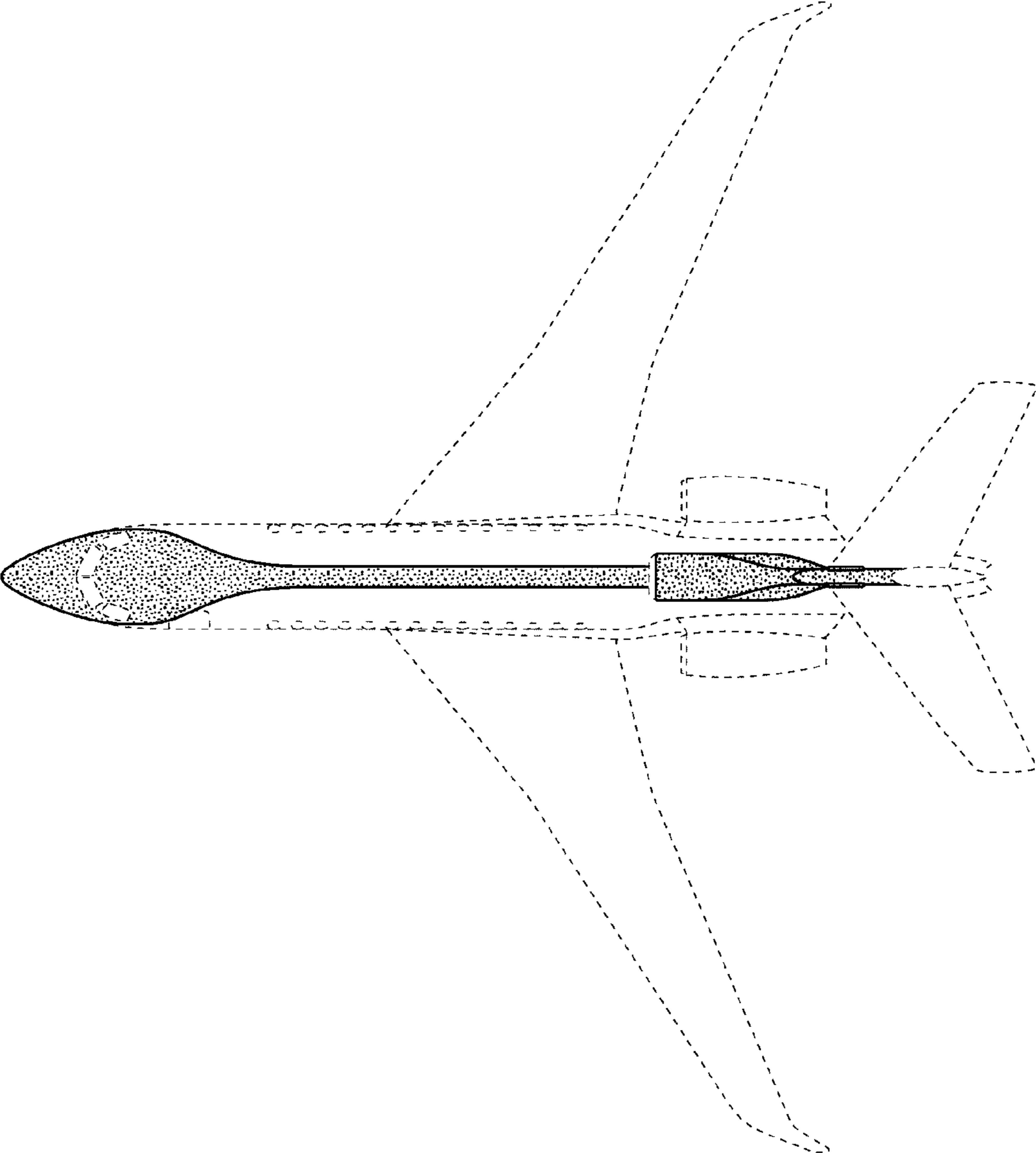

FIG. 4

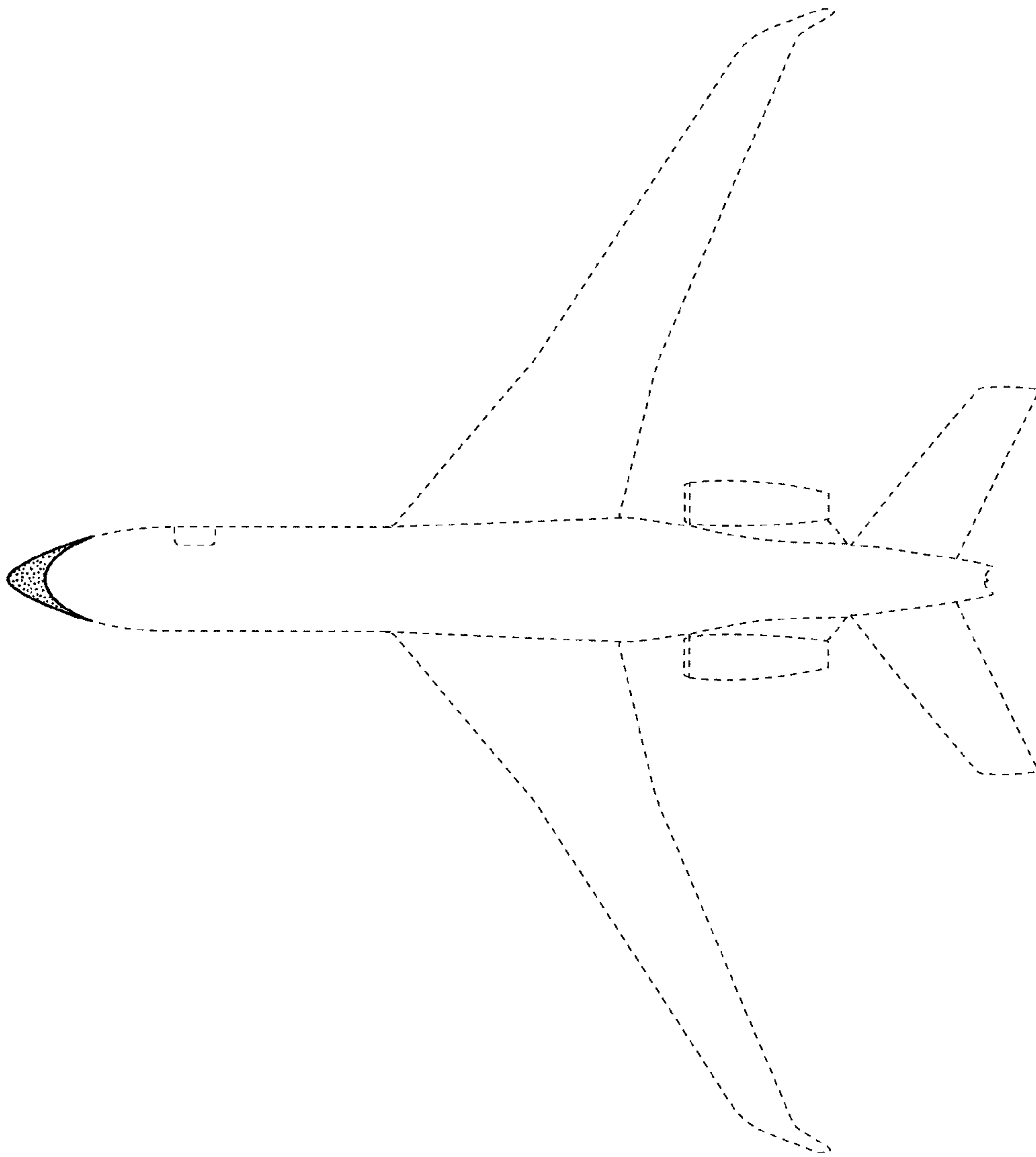

FIG. 5

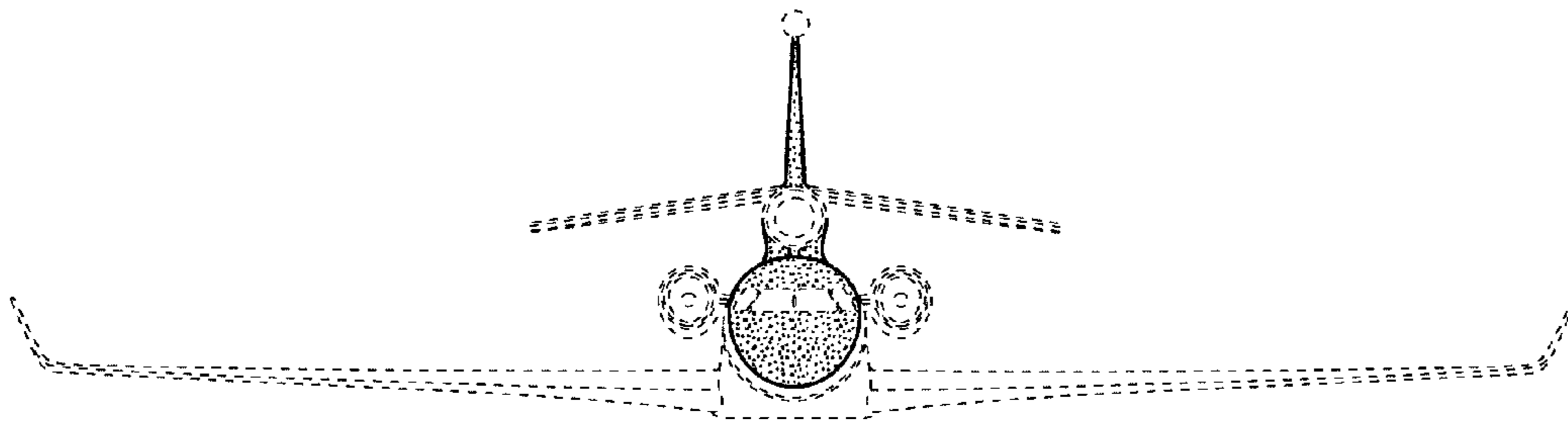

FIG. 6

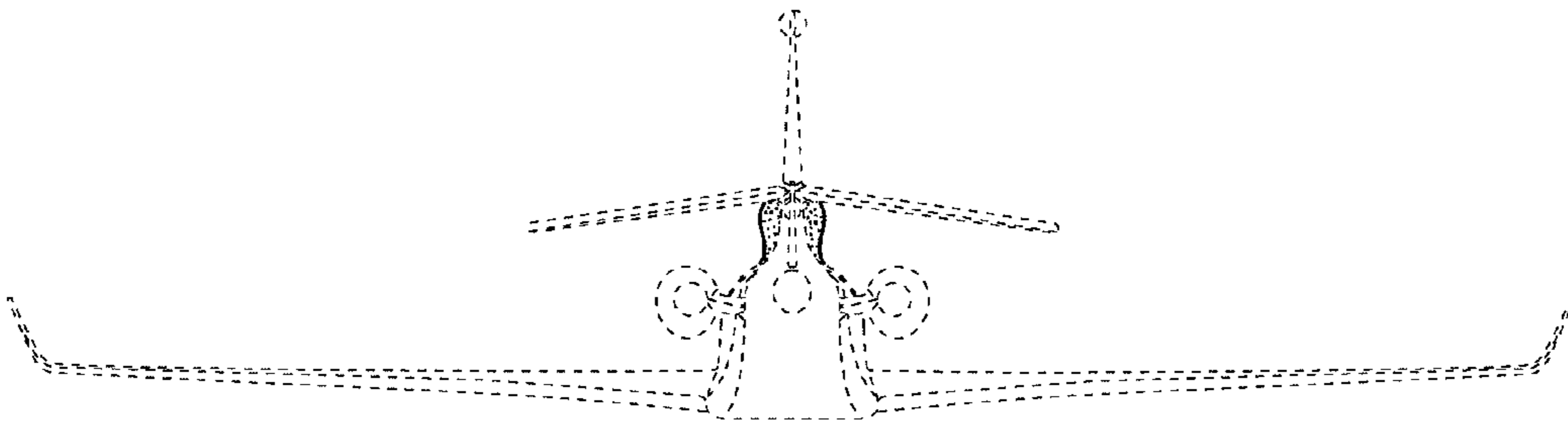

FIG. 7