



US00D731873S

(12) **United States Design Patent**  
**Harder**

(10) **Patent No.:** **US D731,873 S**  
(45) **Date of Patent:** **\*\* Jun. 16, 2015**

- (54) **ANTI-THEFT LOCK ASSEMBLY**
- (71) Applicant: **Richard Harder**, Sumner, WA (US)
- (72) Inventor: **Richard Harder**, Sumner, WA (US)
- (\*\*) Term: **14 Years**
- (21) Appl. No.: **29/474,117**
- (22) Filed: **Jan. 6, 2014**

**Related U.S. Application Data**

- (63) Continuation of application No. 13/435,155, filed on Mar. 30, 2012, now abandoned.
- (51) **LOC (10) Cl.** ..... **08-07**
- (52) **U.S. Cl.**  
USPC ..... **D8/346**
- (58) **Field of Classification Search**  
USPC ..... D8/330, 336, 343–346, 382, 383;  
70/174–179, 158, 163, 154, 252, 299,  
70/DIG. 56, DIG. 59; 292/2, 256, 337, 340,  
292/341, 14, 345  
CPC ..... F16B 1/00; F16B 41/00; F16B 41/02;  
F16K 35/06  
See application file for complete search history.

(56) **References Cited**

**U.S. PATENT DOCUMENTS**

122,396 A	1/1872	McIlhenny	
733,731 A	7/1903	Mooney et al.	
1,639,150 A	8/1927	Schneider	
2,048,424 A	7/1936	Caldwell	
2,565,659 A	8/1951	Kontra	
2,785,564 A	3/1957	Rossi	
3,245,240 A	4/1966	De Forrest	
3,269,159 A	8/1966	Young	
4,058,994 A	11/1977	Coppola	
4,377,245 A *	3/1983	Patty	220/822
4,405,161 A *	9/1983	Young et al.	285/80
4,541,256 A	9/1985	Green	

4,570,470 A *	2/1986	Gray, Sr.	70/428
4,630,456 A	12/1986	Nielsen, Jr.	
4,719,980 A *	1/1988	Knothe et al.	177/180
4,777,811 A	10/1988	Binkley et al.	
4,798,069 A *	1/1989	DeForrest, Sr.	70/428
4,803,858 A	2/1989	Parker	
5,193,366 A *	3/1993	Brinkman	70/18
D349,034 S *	7/1994	Webster	D8/333
5,363,677 A	11/1994	Cox	
5,377,511 A	1/1995	Meckbach	
5,412,962 A	5/1995	Thompson	
5,417,093 A	5/1995	Heiberg	
D389,442 S *	1/1998	Kantor	D12/162
D454,051 S *	3/2002	Drake	D8/346
6,745,437 B2	6/2004	Gremillion, III	
D523,789 S *	6/2006	Caselberry	D12/133
D579,376 S *	10/2008	Hsiao	D11/221
D630,492 S *	1/2011	Faulkner	D8/346
D652,708 S *	1/2012	Figureida	D8/346
2009/0158791 A1	6/2009	Hudman et al.	

**OTHER PUBLICATIONS**

U.S. Appl. No. 13/435,155, Non-Final Office Action, Sep. 27, 2012.  
(Continued)

*Primary Examiner* — Prabhakar Deshmukh  
(74) *Attorney, Agent, or Firm* — George A. Leone; Citadel Patent Law

(57) **CLAIM**  
The ornamental design for an anti-theft lock assembly, as shown and described.

**DESCRIPTION**

FIG. 1 is a front elevational view of an anti-theft lock assembly showing my new design;  
FIG. 2 is a rear elevational view thereof;  
FIG. 3 is a right side elevational view thereof;  
FIG. 4 is a left side elevational view thereof;  
FIG. 5 is a top plan view thereof; and,  
FIG. 6 is a bottom plan view thereof.

**1 Claim, 2 Drawing Sheets**

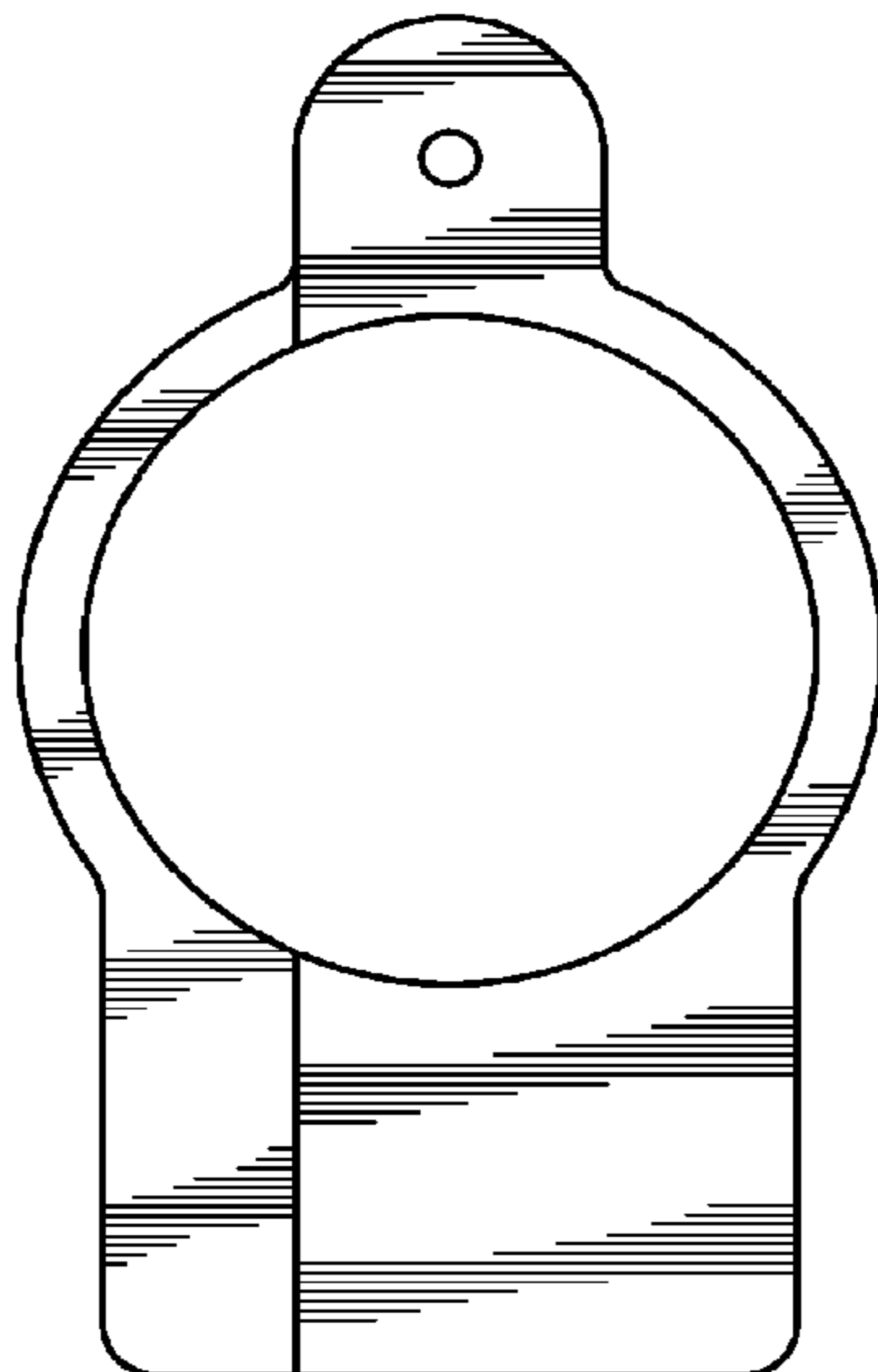

(56)

**References Cited**

OTHER PUBLICATIONS

U.S. Appl. No. 13/435,155, Response to Non-Final Office Action,  
Feb. 22, 2013.

U.S. Appl. No. 13/435,155, Applicant Initiated Interview Summary,  
Jul. 19, 2013.

U.S. Appl. No. 13/435,155, Final Office Action, Oct. 7, 2013.

\* cited by examiner

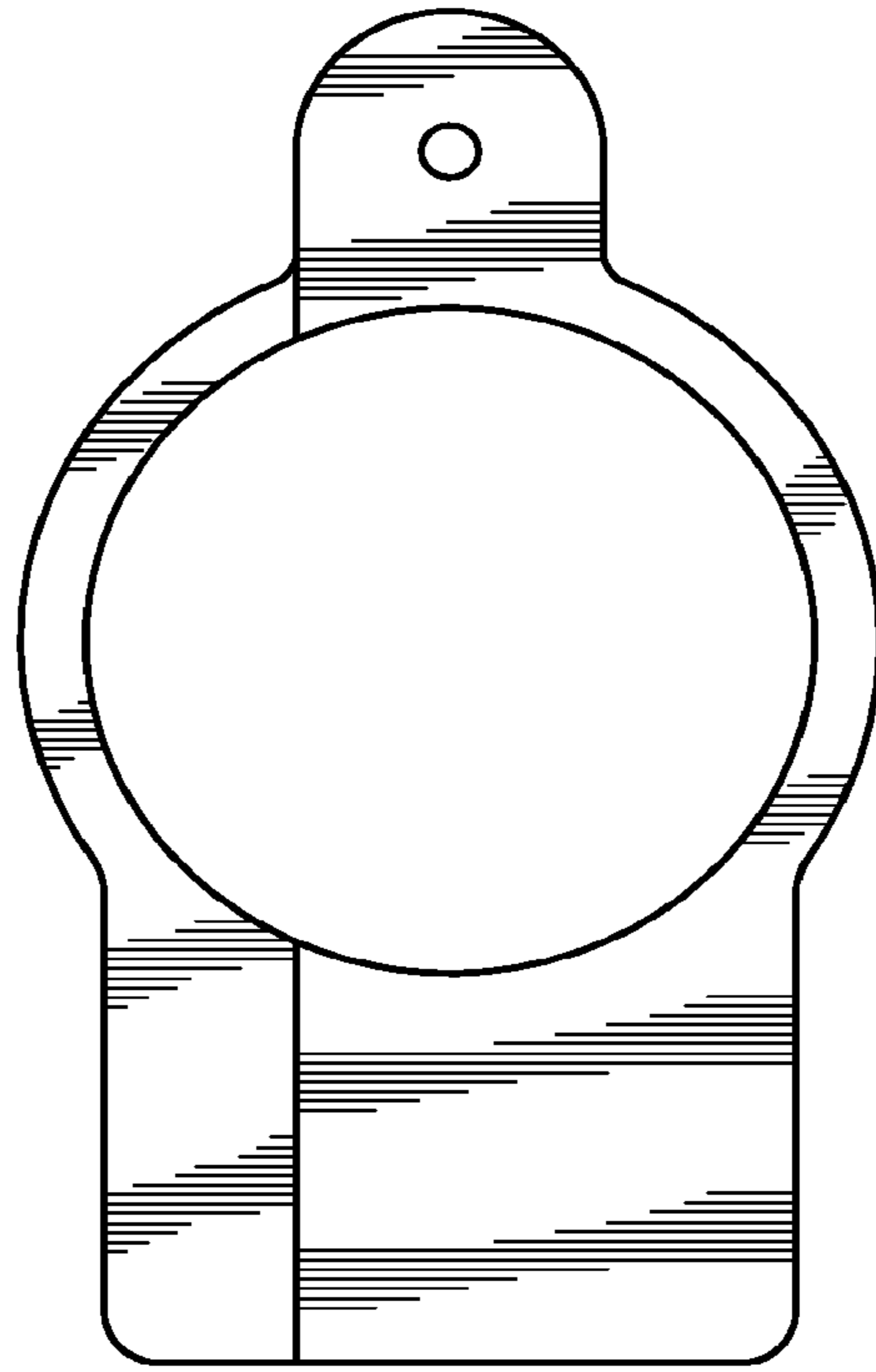

**FIG. 1**

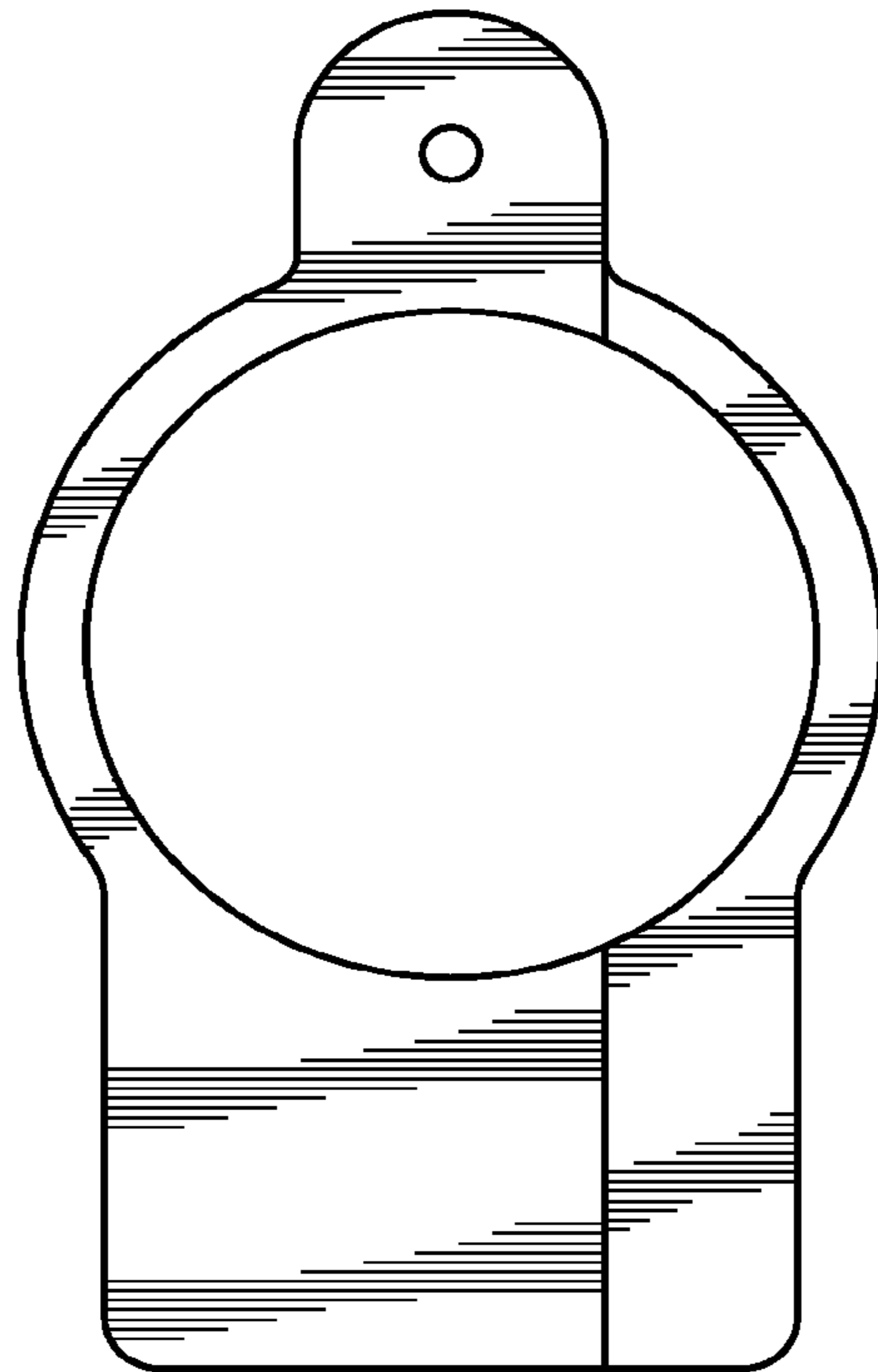

**FIG. 2**

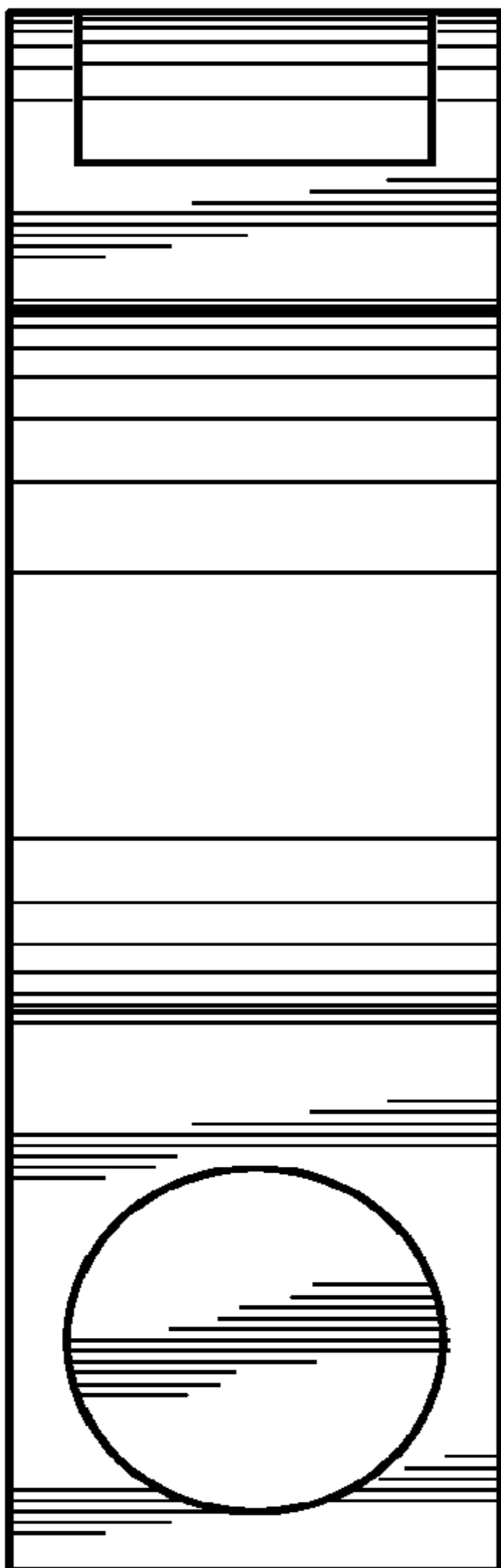

FIG. 3

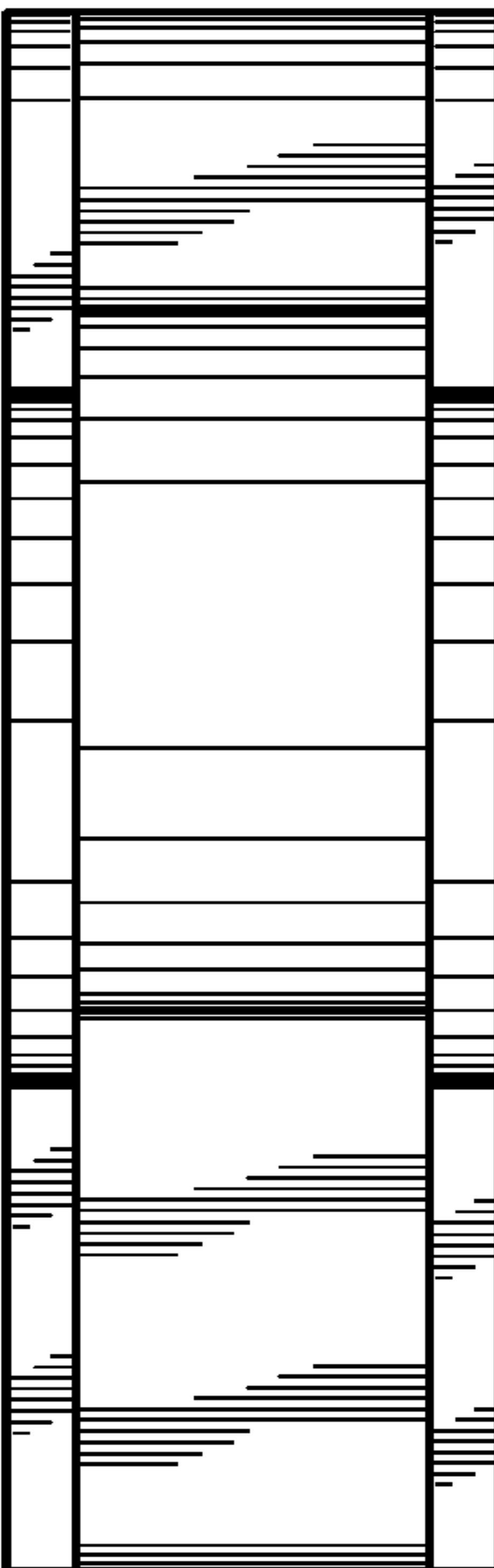

FIG. 4

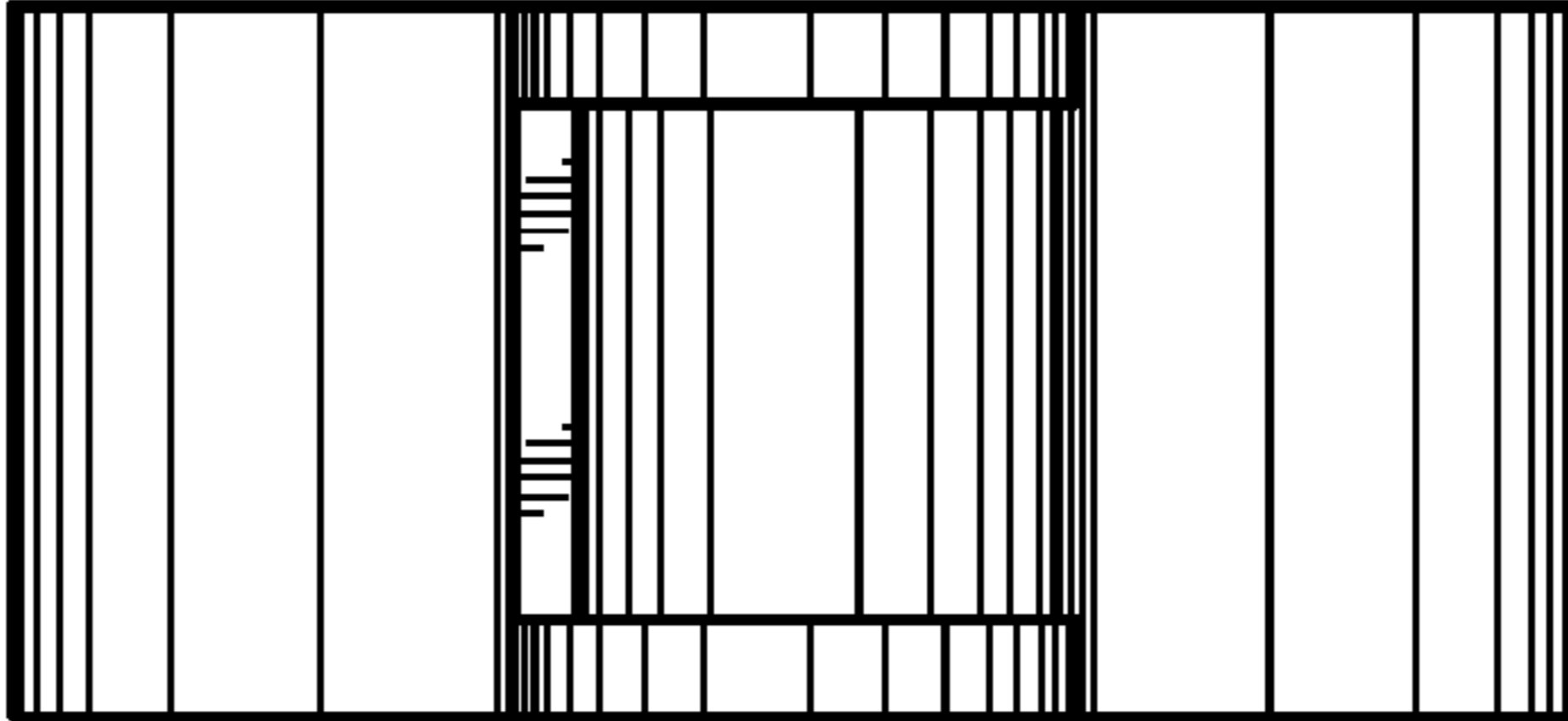

FIG. 5

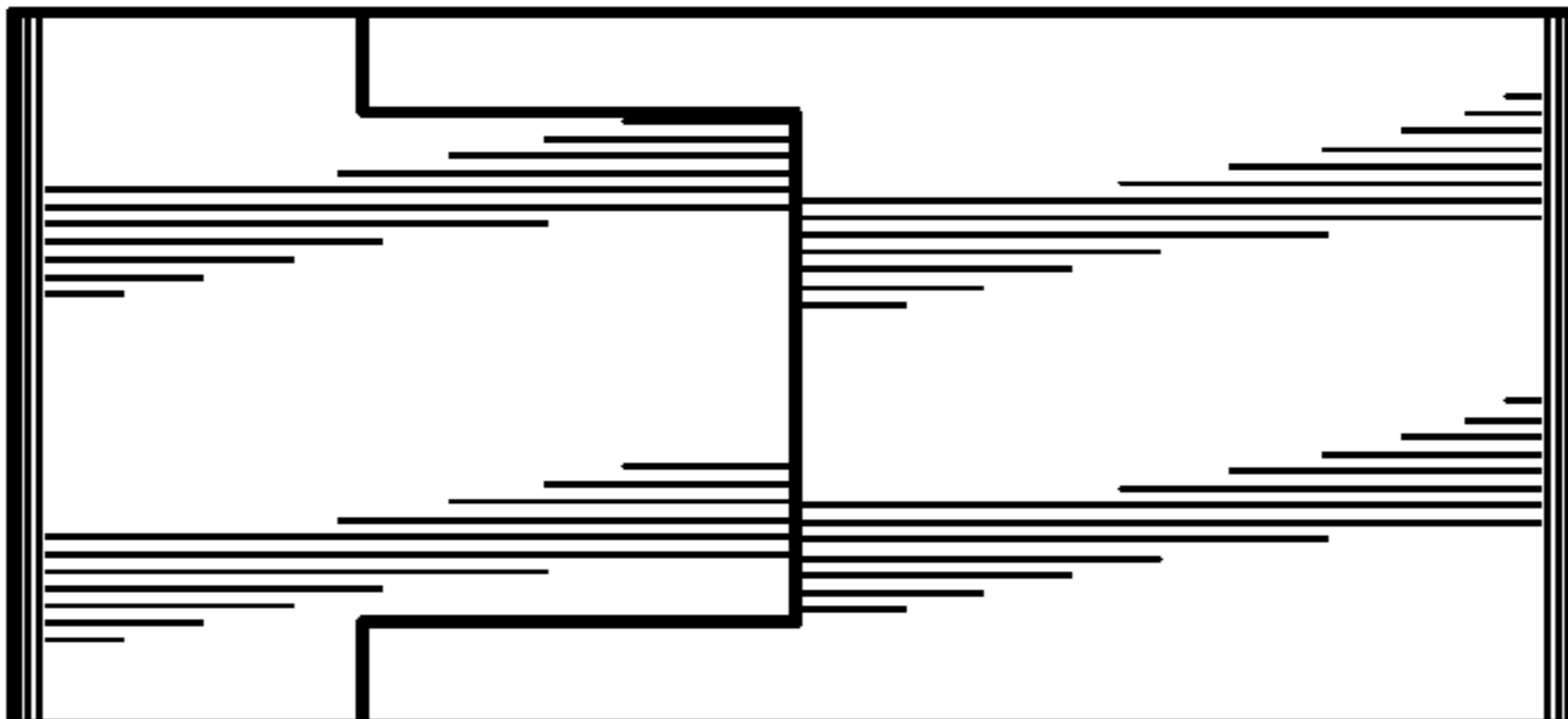

FIG. 6