



US00D731555S

(12) **United States Design Patent**
Lee

(10) **Patent No.:** **US D731,555 S**
(45) **Date of Patent:** **** Jun. 9, 2015**

(54) **PISTON FOR PNEUMATIC AUTOMOTIVE LIFTING DEVICE**

D704,225 S * 5/2014 Lee D15/5
D704,226 S * 5/2014 Lee D15/5
2008/0219861 A1 * 9/2008 Raleigh et al. 417/271

(75) Inventor: **Steven David Lee**, Kailua, HI (US)

* cited by examiner

(73) Assignee: **STEALTH INNOVATIVE SYSTEMS, LLC**, Kailua, HI (US)

Primary Examiner — T. Chase Nelson

Assistant Examiner — Ania Aman

(**) Term: **14 Years**

(74) *Attorney, Agent, or Firm* — Martin E. Hsia; Keri Ann K. S. Krzykowski

(21) Appl. No.: **29/421,230**

(57) **CLAIM**

(22) Filed: **Jun. 14, 2012**

The ornamental design for a piston for pneumatic automotive lifting device, as shown and described.

Related U.S. Application Data

DESCRIPTION

(63) Continuation-in-part of application No. 29/395,808, filed on Apr. 3, 2012, now Pat. No. Des. 704,225, which is a continuation-in-part of application No. 29/395,809, filed on Apr. 3, 2012, now Pat. No. Des. 704,226.

FIG. 1 is a perspective view of a first presently preferred embodiment of the piston for pneumatic automotive lifting device of my new design;

(51) **LOC (10) Cl.** **15-01**

FIG. 2 is an elevational view thereof from the front, the elevational views from the right, left, and rear thereof being identical;

(52) **U.S. Cl.**

USPC **D15/5**

FIG. 3 is a top plan view thereof;

(58) **Field of Classification Search**

USPC D15/1-9; 417/410.1, 359, 415, 416, 417/234, 321, 265, 405; D23/231, 232; 123/193.3, 307; D12/159

FIG. 4 is a bottom plan view thereof;

See application file for complete search history.

FIG. 5 is a perspective cut-away view thereof along the line 5-5 in FIG. 1;

(56) **References Cited**

U.S. PATENT DOCUMENTS

4,541,377 A * 9/1985 Amos 123/307
5,913,665 A * 6/1999 Sundby et al. 417/413.1
D431,802 S * 10/2000 Sintorn et al. D12/159
D515,590 S * 2/2006 Freitas D15/7
D633,529 S * 3/2011 Hamada et al. D15/7
D638,036 S * 5/2011 Hamada et al. D15/7

FIG. 6 is a perspective view of a second presently preferred embodiment of the piston for pneumatic automotive lifting device of my new design;

FIG. 7 is an elevational view thereof from the front, the elevational views from the right, left, and rear thereof being identical;

FIG. 8 is a top plan view thereof;

FIG. 9 is a bottom plan view thereof; and,

FIG. 10 is a perspective cut-away view thereof along the line 10-10 in FIG. 6.

1 Claim, 2 Drawing Sheets

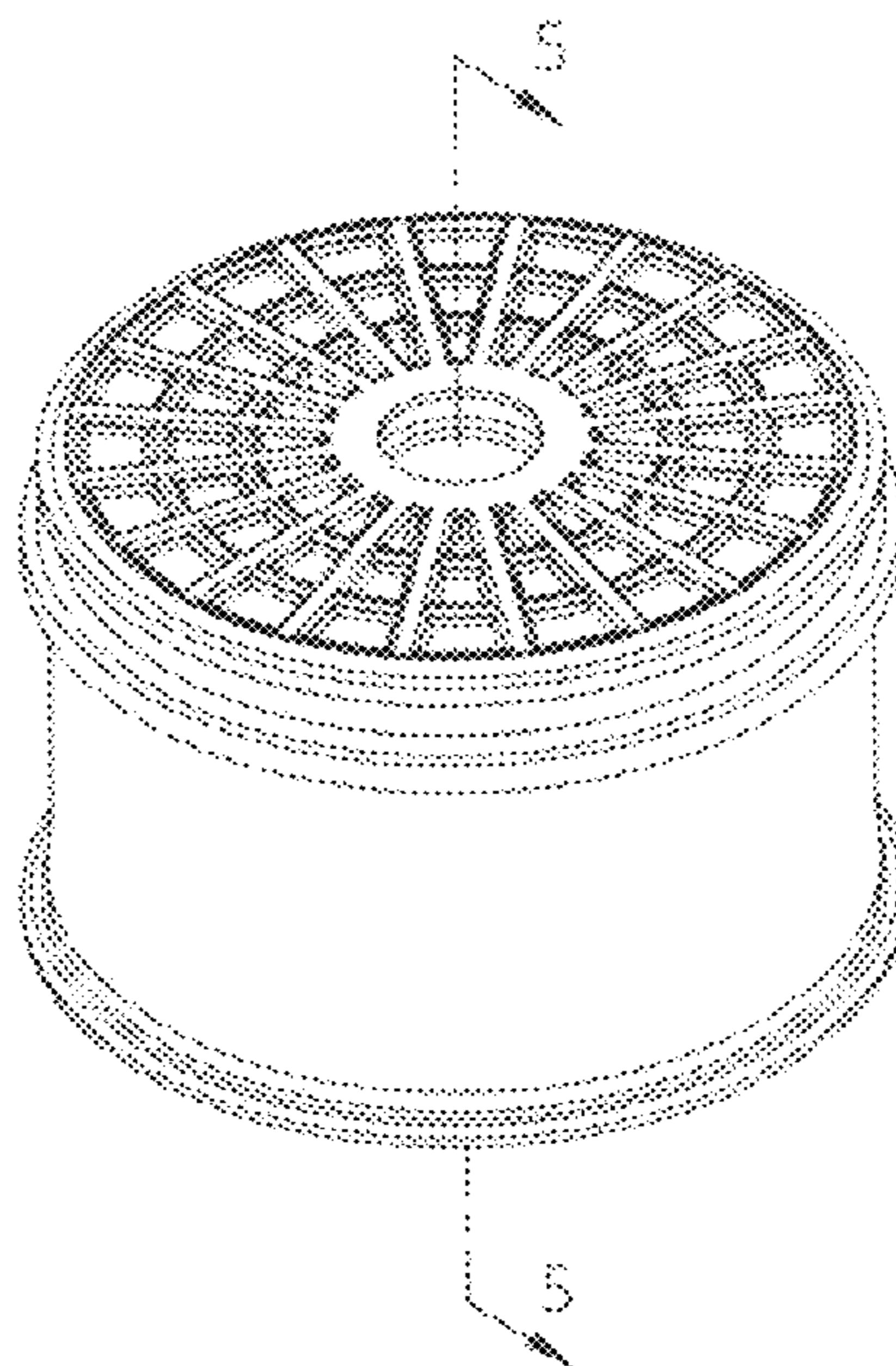

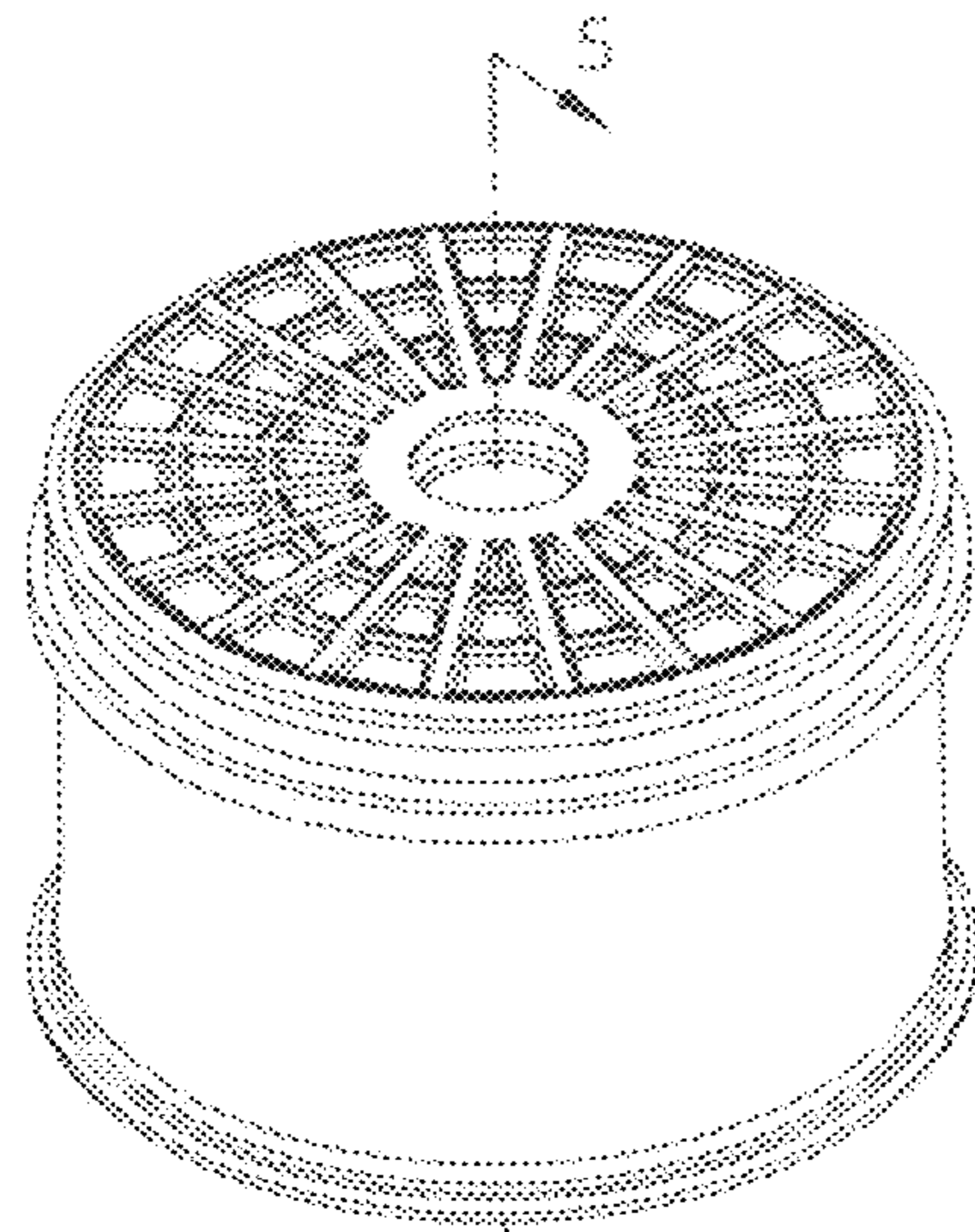

FIG. 1

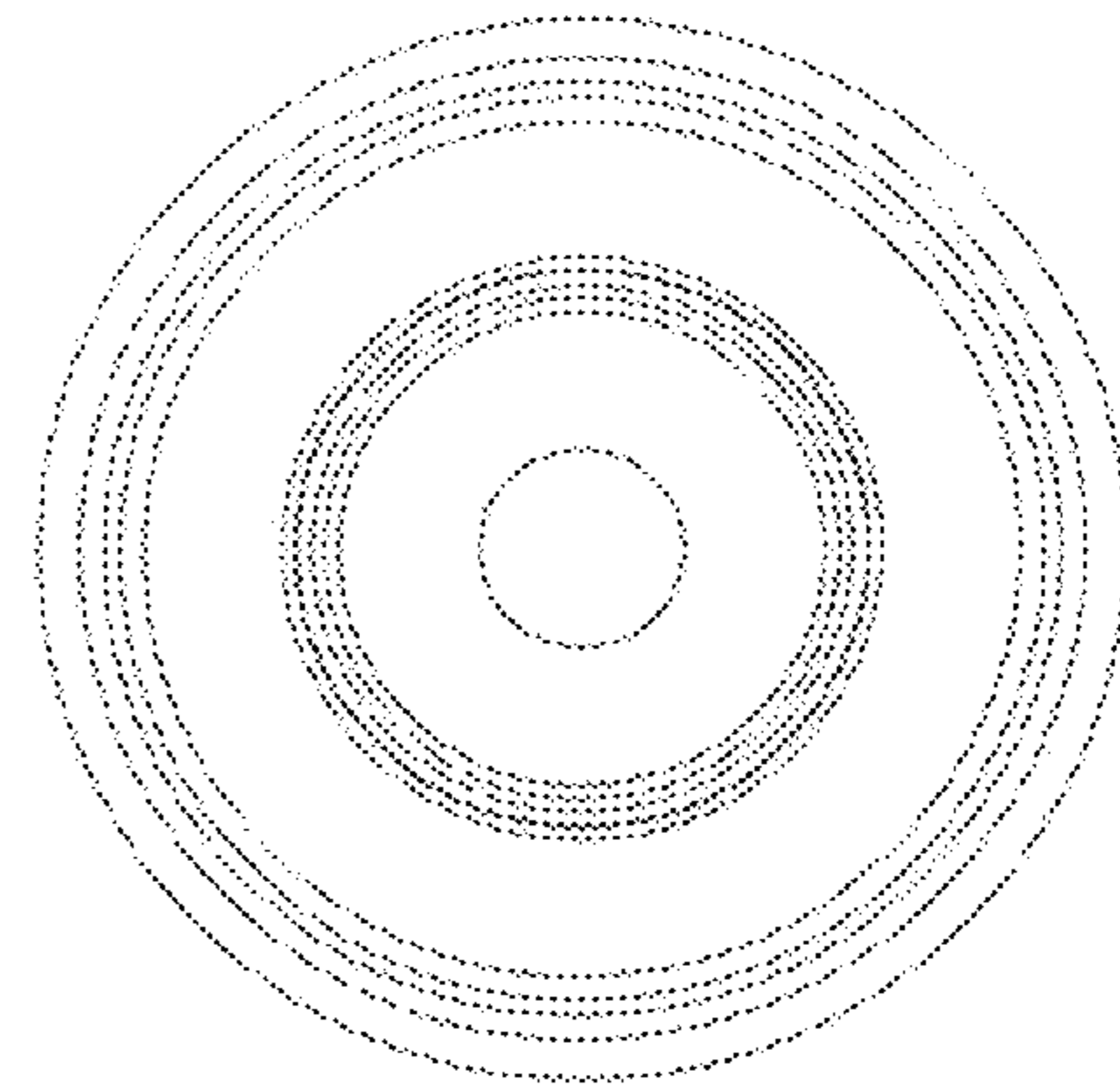

FIG. 4

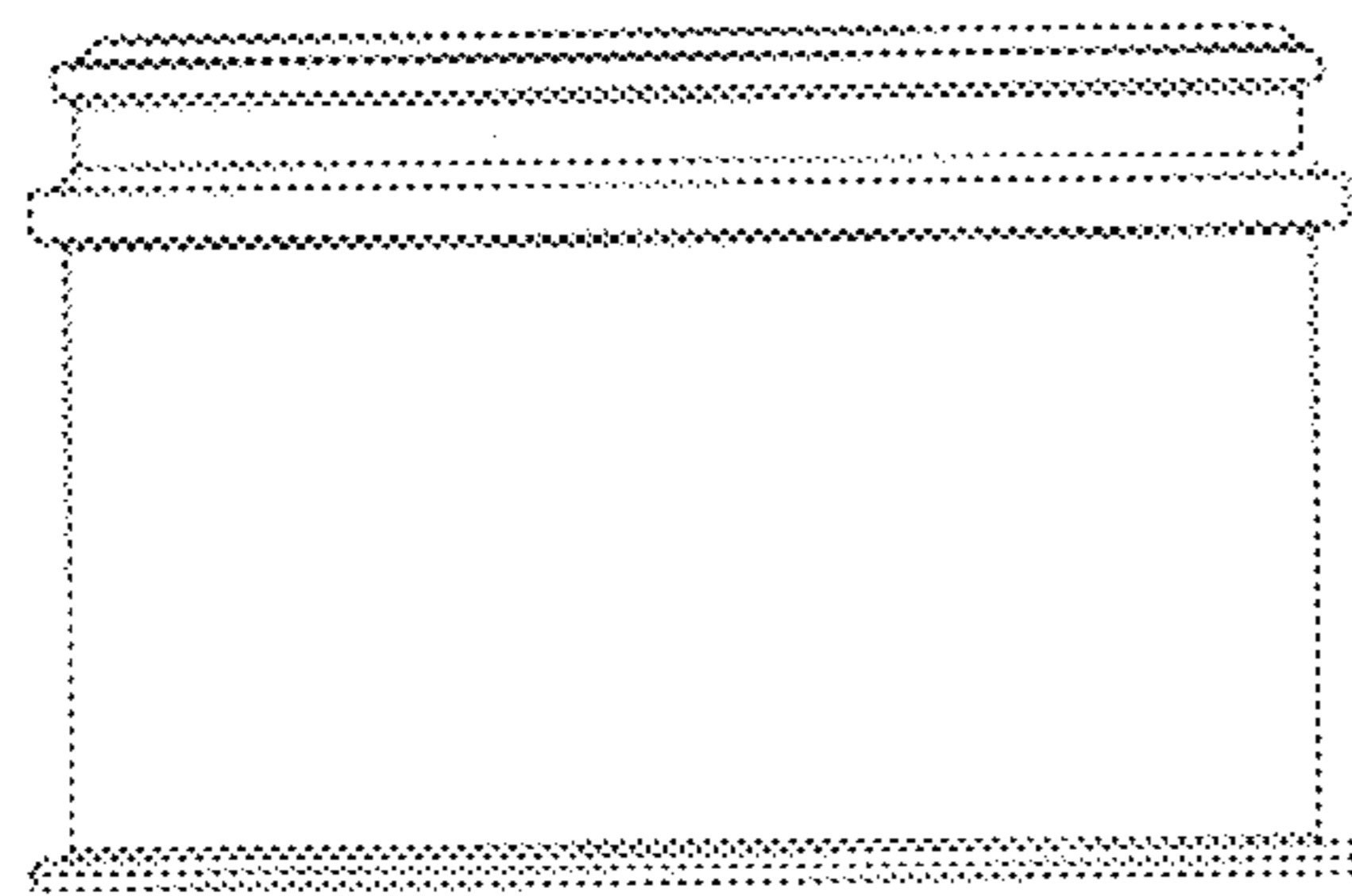

FIG. 2

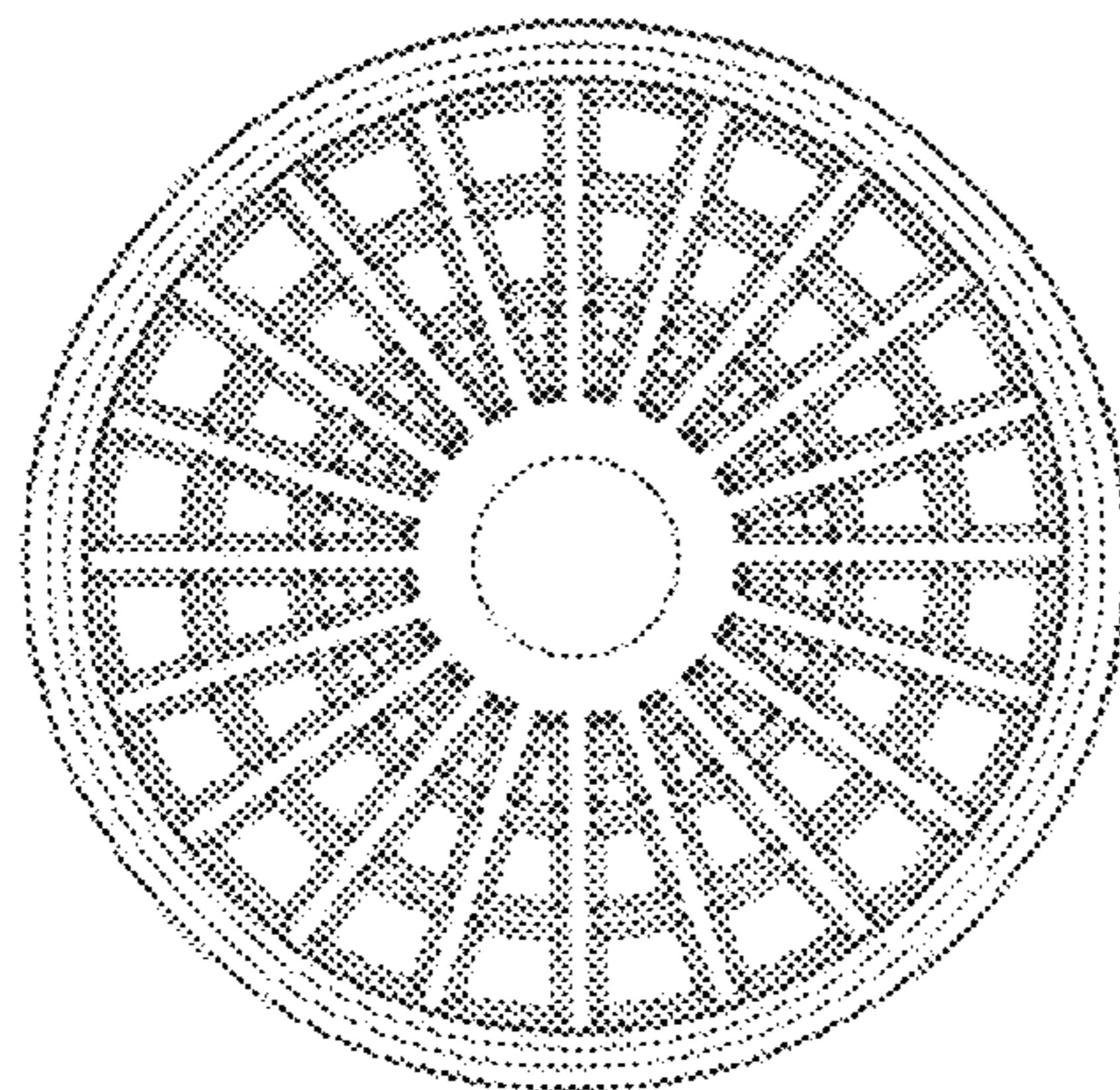

FIG. 3

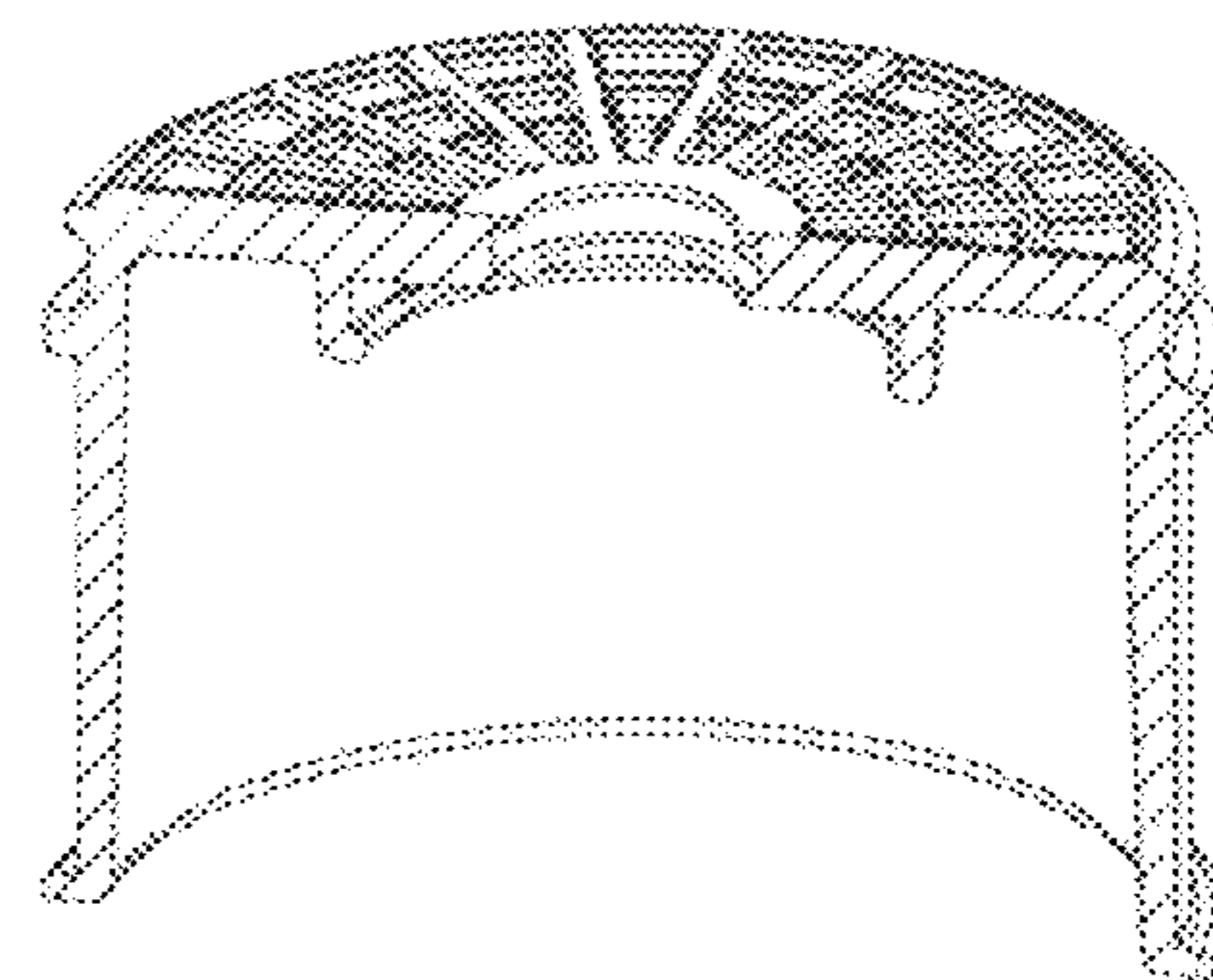

FIG. 5

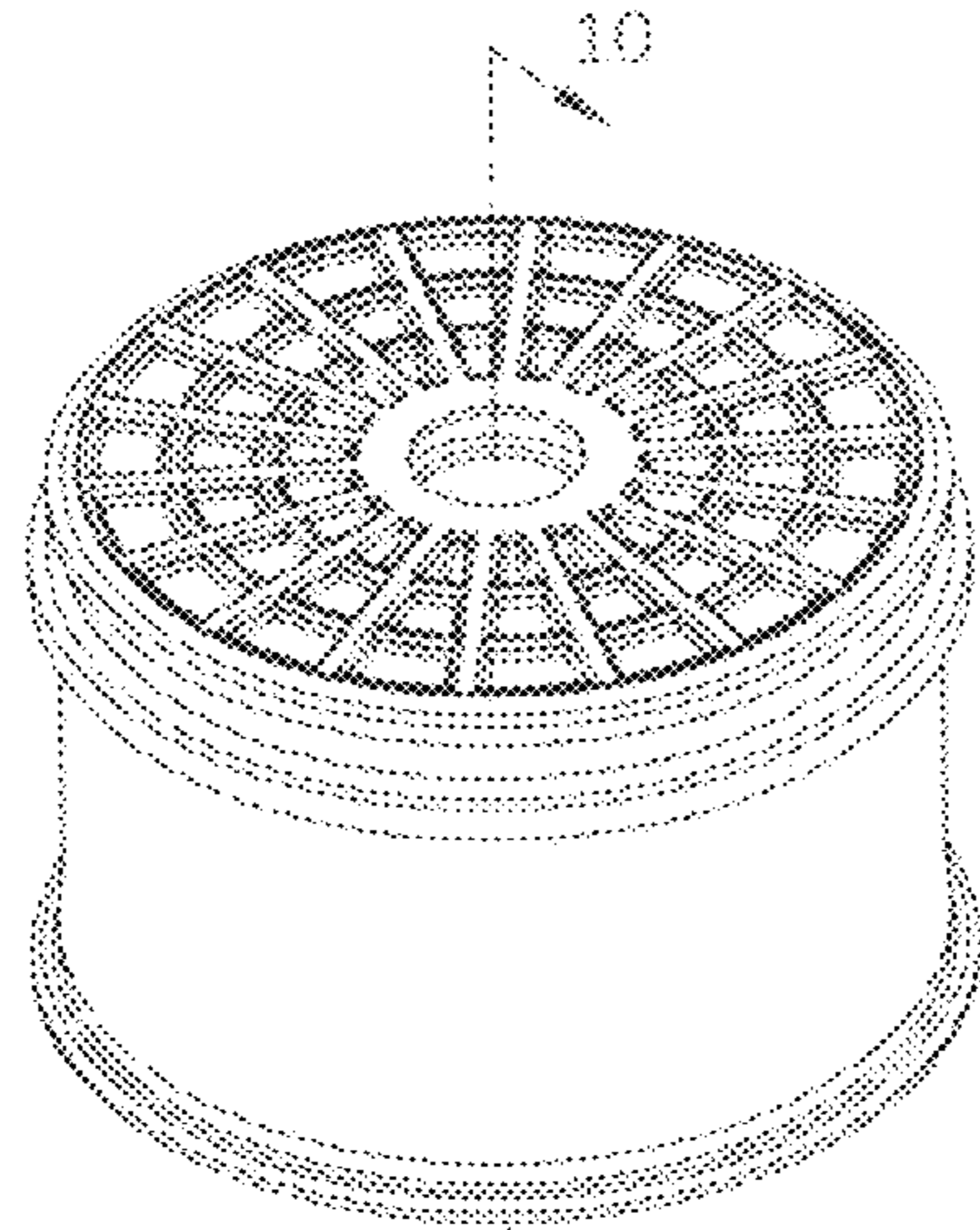

FIG. 6

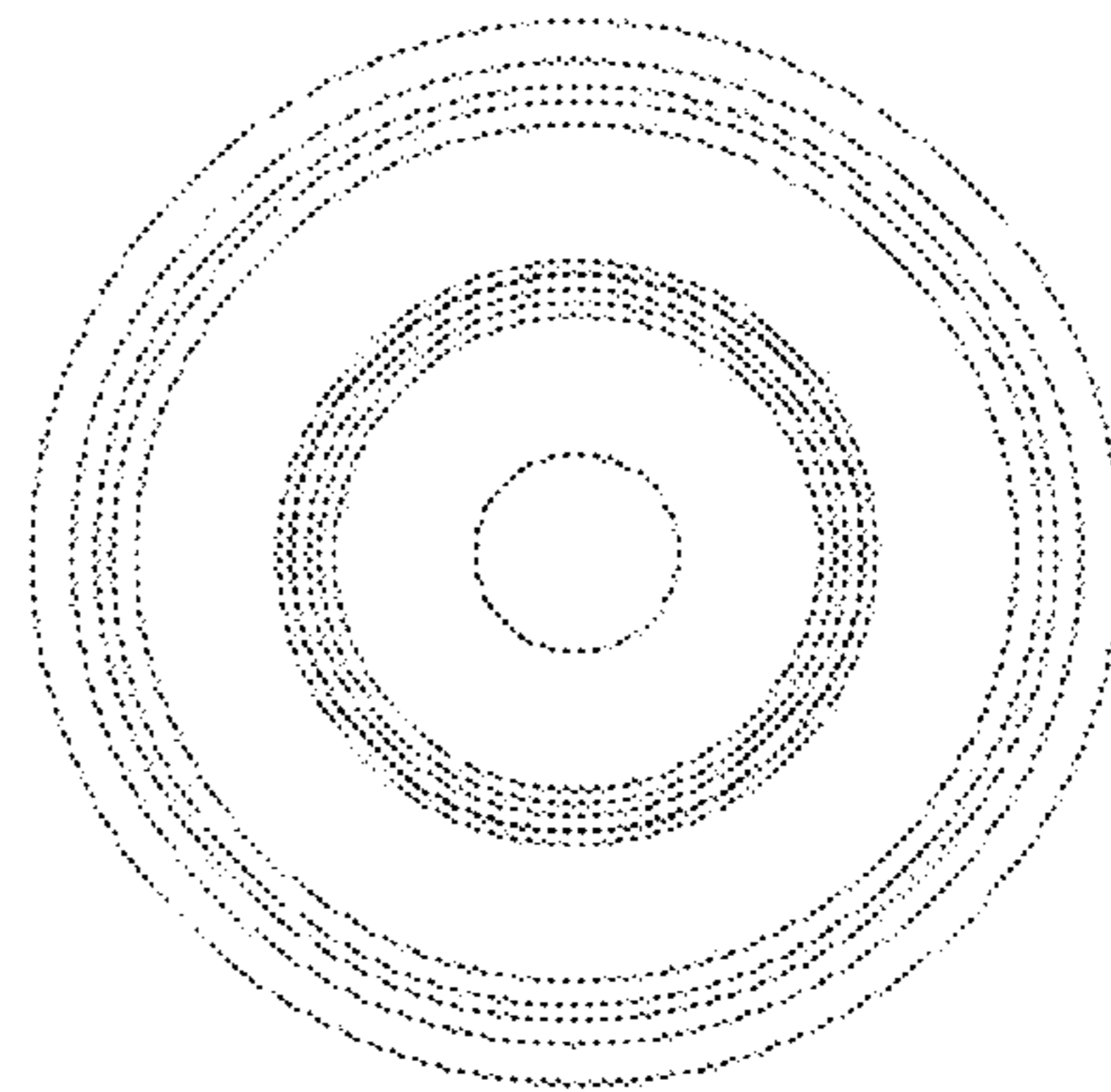

FIG. 9

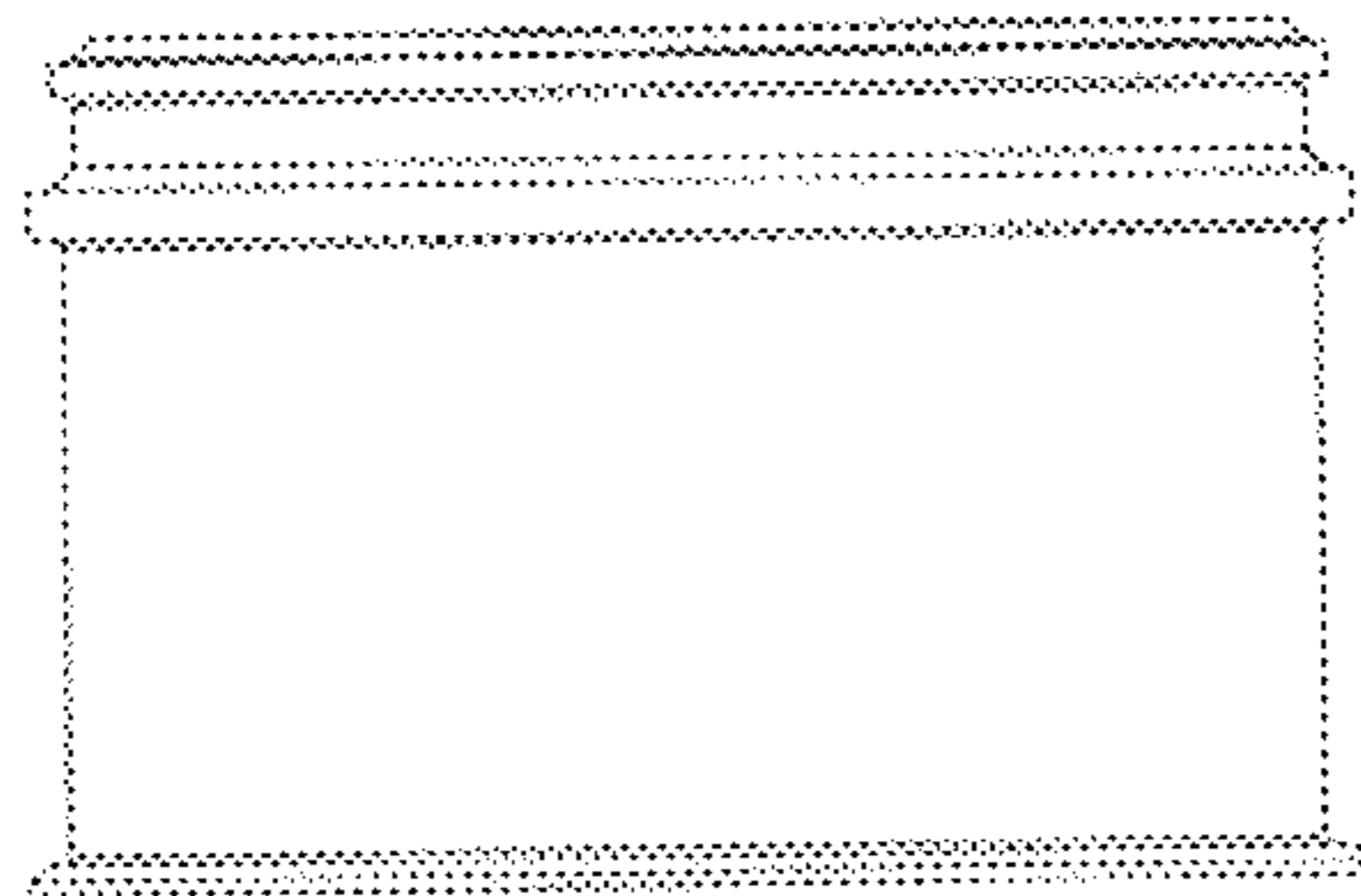

FIG. 7

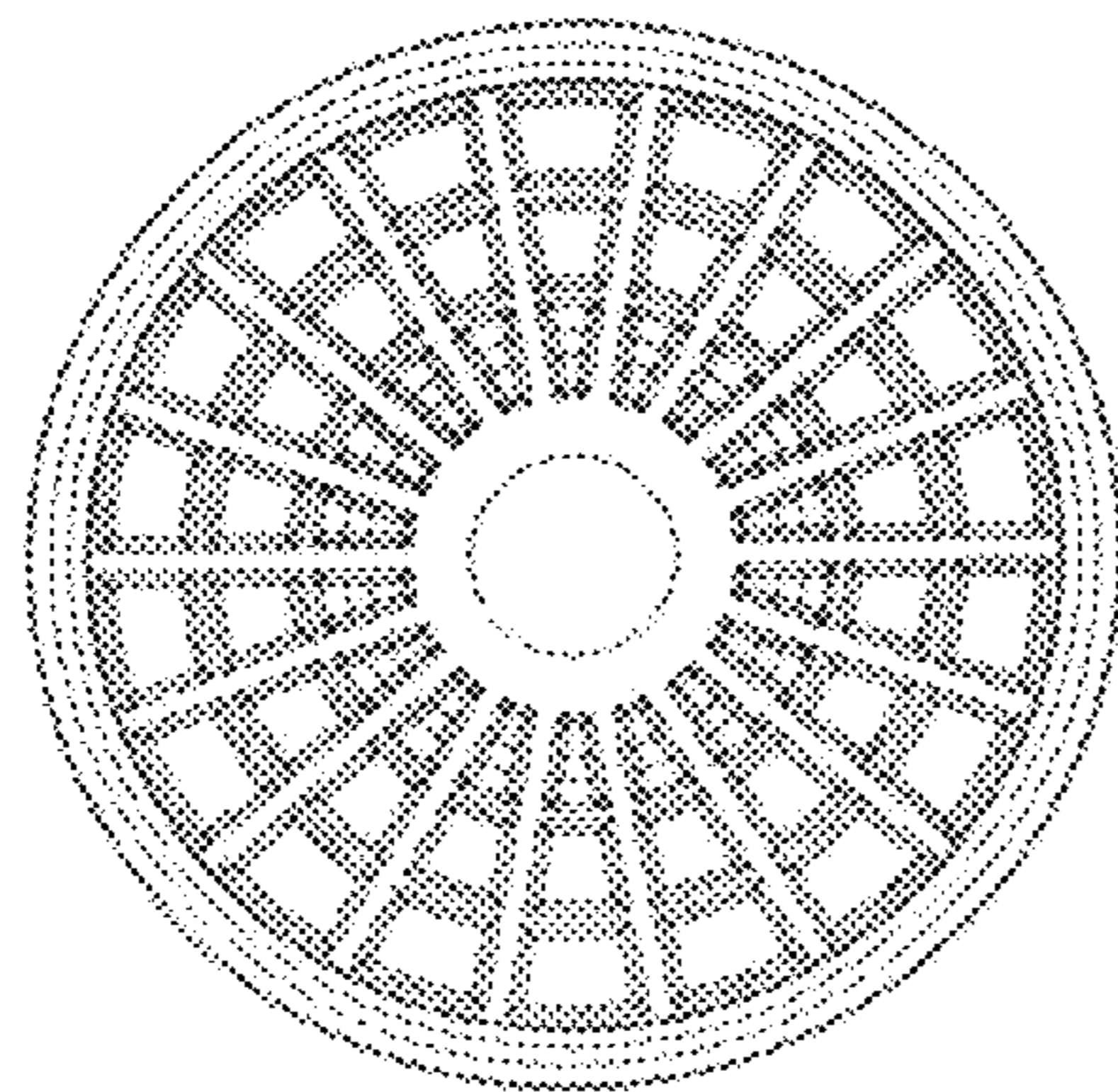

FIG. 8

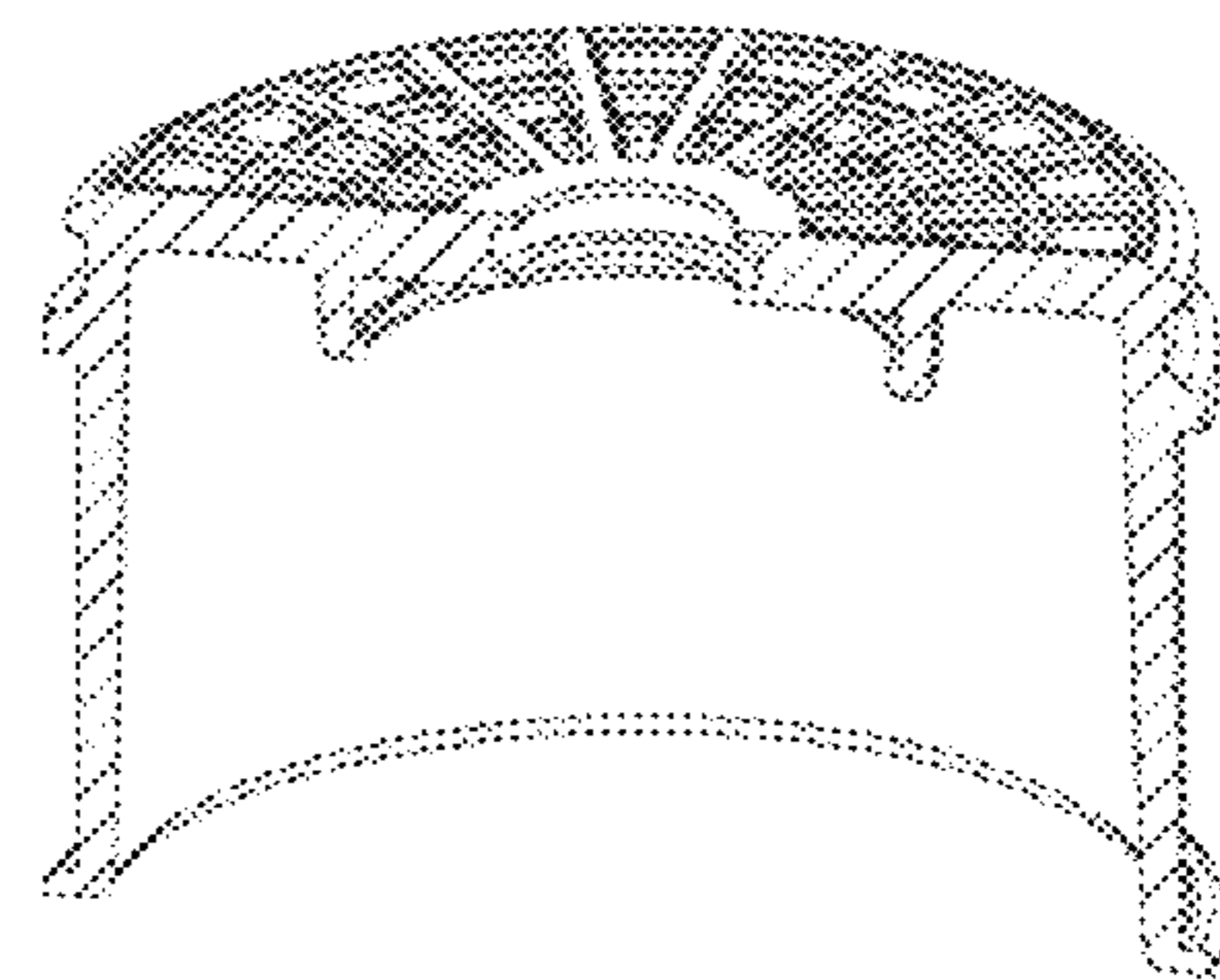

FIG. 10