



US00D731373S

(12) **United States Design Patent**
Howell et al.

(10) **Patent No.:** **US D731,373 S**
(45) **Date of Patent:** **** Jun. 9, 2015**

- (54) **VEHICLE FRONT FENDER**
- (71) Applicants: **Gregory A Howell**, Farmington, MI (US); **Mark Allen**, Oxford, MI (US)
- (72) Inventors: **Gregory A Howell**, Farmington, MI (US); **Mark Allen**, Oxford, MI (US)
- (73) Assignee: **FCA US LLC**, Auburn Hills, MI (US)
- (**) Term: **14 Years**
- (21) Appl. No.: **29/489,159**
- (22) Filed: **Apr. 28, 2014**

- D554,564 S 11/2007 Vardis et al.
- D620,407 S * 7/2010 Froehlich D12/184
- D650,721 S 12/2011 Galante et al.
- D659,616 S * 5/2012 Matsumoto et al. D12/184
- D669,829 S * 10/2012 Iwao et al. D12/184
- D680,045 S * 4/2013 Hamilton et al. D12/184
- D683,679 S * 6/2013 Platto et al. D12/184
- D685,305 S * 7/2013 Tase et al. D12/184
- D691,530 S * 10/2013 Song et al. D12/184

(Continued)

Primary Examiner — Melody Brown
(74) *Attorney, Agent, or Firm* — Ralph E Smith

(57) **CLAIM**

The ornamental design for a vehicle front fender, as shown and described.

Related U.S. Application Data

- (63) Continuation-in-part of application No. 29/434,717, filed on Oct. 16, 2012, now Pat. No. Des. 703,583.
- (51) **LOC (10) Cl.** **12-16**
- (52) **U.S. Cl.**
USPC **D12/184**
- (58) **Field of Classification Search**
USPC D12/184, 196, 90-92, 181; 280/152.1, 280/847-849, 851; 296/181.1, 181.5
CPC B62D 25/16; B62D 25/18; B62D 25/161; B62D 25/168; B62D 25/184; B62D 25/186; B62D 25/188; D62D 25/182
See application file for complete search history.

DESCRIPTION

FIG. 1 is a side perspective view of a vehicle front fender showing the right side fender of our new design;
 FIG. 2 is a rear perspective view thereof;
 FIG. 3 is a top plan view thereof;
 FIG. 4 is a side elevational view thereof;
 FIG. 5 is an opposite side elevational view thereof;
 FIG. 6 is a front elevational view thereof;
 FIG. 7 is a rear elevational view thereof;
 FIG. 8 is a bottom plan view thereof;
 FIG. 9 is a side perspective view of a second embodiment of a vehicle front fender showing the left side fender of our new design;
 FIG. 10 is a side perspective view of FIG. 9;
 FIG. 11 is a top plan view of FIG. 9;
 FIG. 12 is a side elevational view of FIG. 9;
 FIG. 13 is an opposite side elevational view of FIG. 9;
 FIG. 14 is a front elevational view of FIG. 9;
 FIG. 15 is a rear elevational view of FIG. 9; and,
 FIG. 16 is a bottom plan view of FIG. 9.
 It will be understood that the broken lines shown in the drawings illustrate portions of the vehicle front fender that form no part of claimed design.

(56) **References Cited**

U.S. PATENT DOCUMENTS

- D408,329 S 4/1999 Anness et al.
- D416,519 S 11/1999 Won et al.
- D420,939 S 2/2000 Faurote et al.
- D454,813 S 3/2002 Boniface et al.
- D476,268 S 6/2003 Castiglione et al.
- D519,066 S 4/2006 Ney et al.
- D534,097 S 12/2006 Renkert et al.
- D534,458 S 1/2007 Renkert et al.
- D551,124 S 9/2007 Aneiros et al.

1 Claim, 6 Drawing Sheets

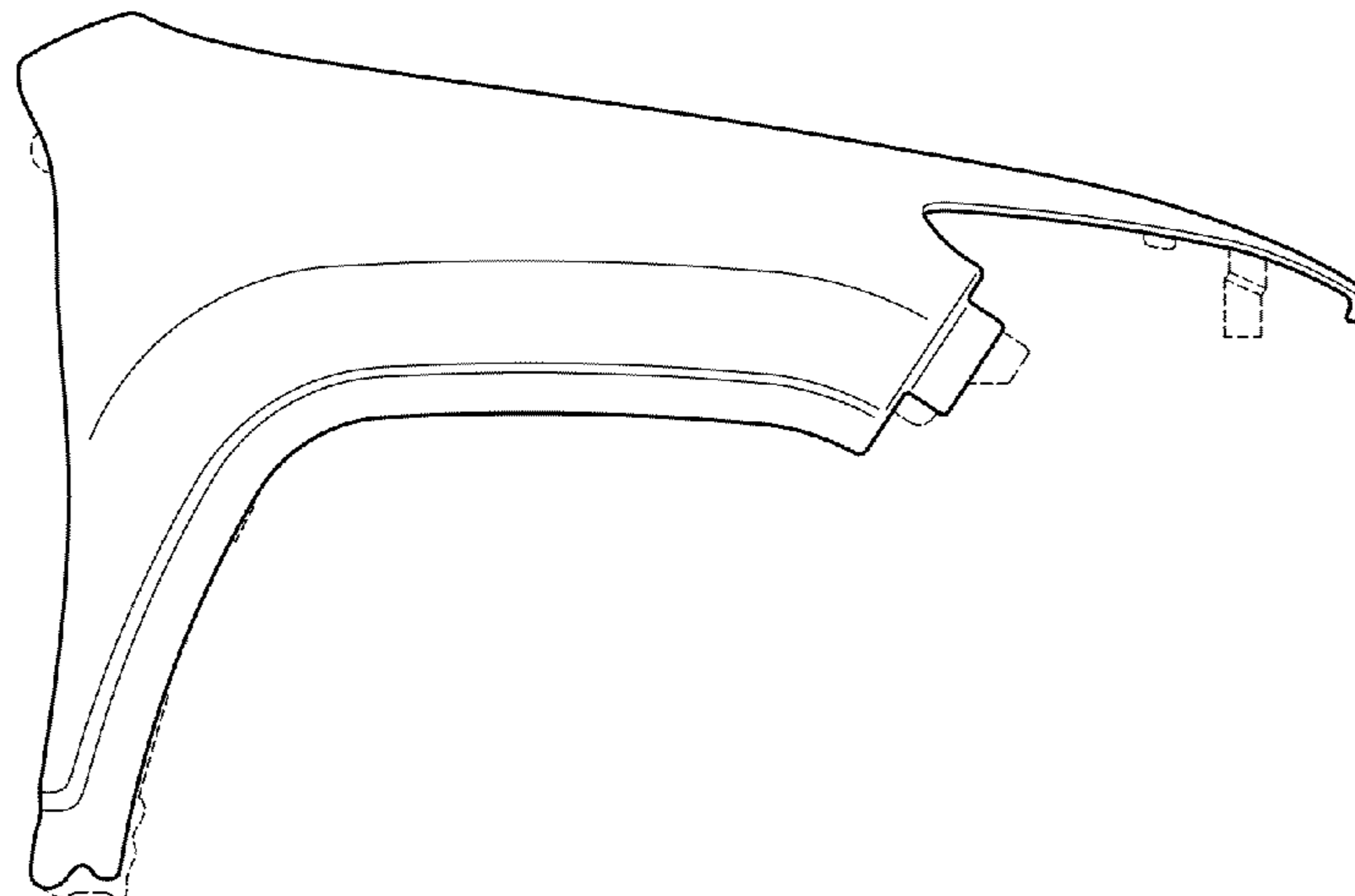

US D731,373 S

Page 2

(56)

References Cited

U.S. PATENT DOCUMENTS

D703,583 S	4/2014	Howell et al.	
D709,010 S *	7/2014	Mays et al.	D12/184
D711,797 S *	8/2014	Tsuchida et al.	D12/184
D699,649 S *	2/2014	Okue et al.	D12/184

* cited by examiner

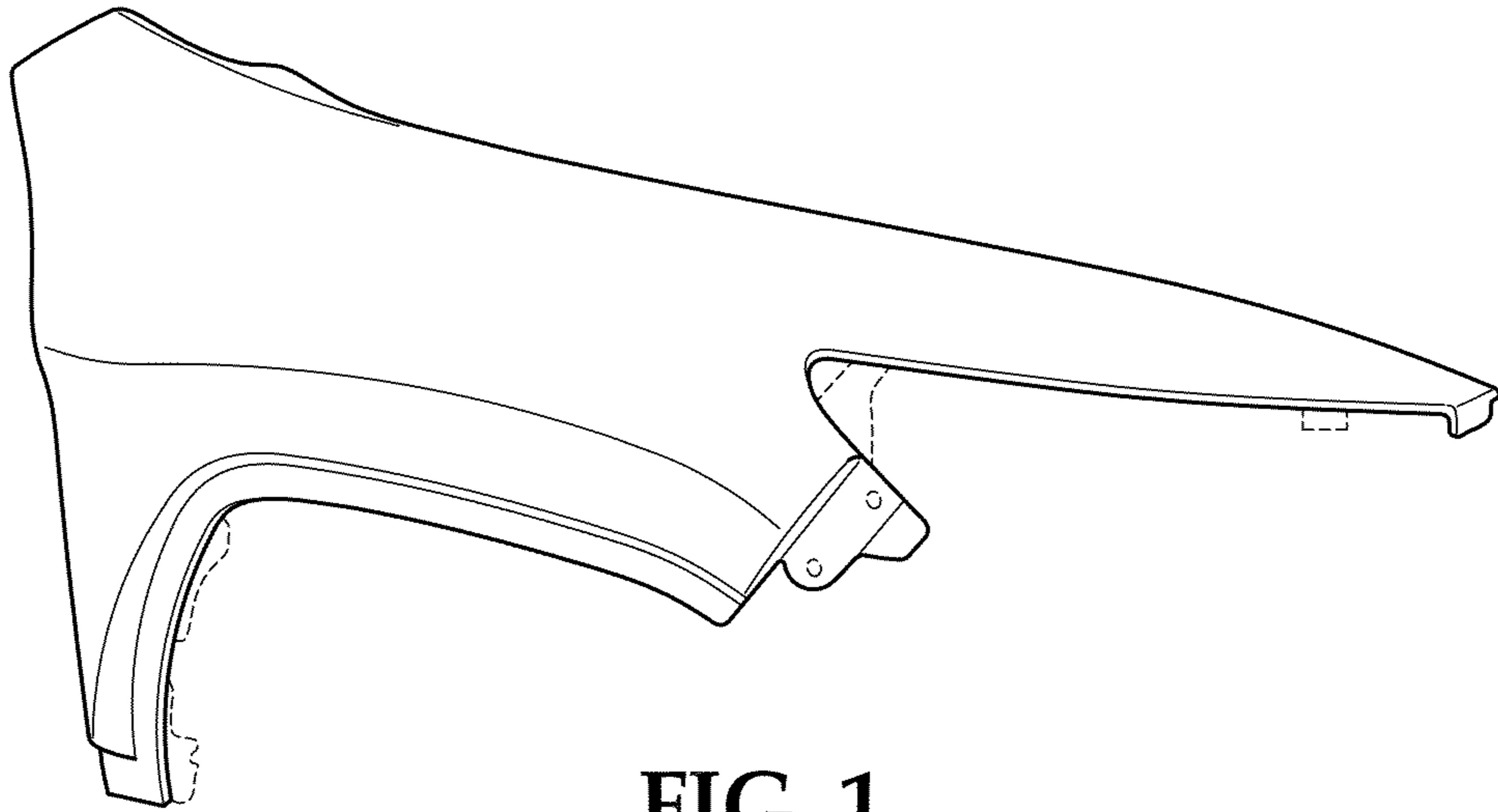

FIG. 1

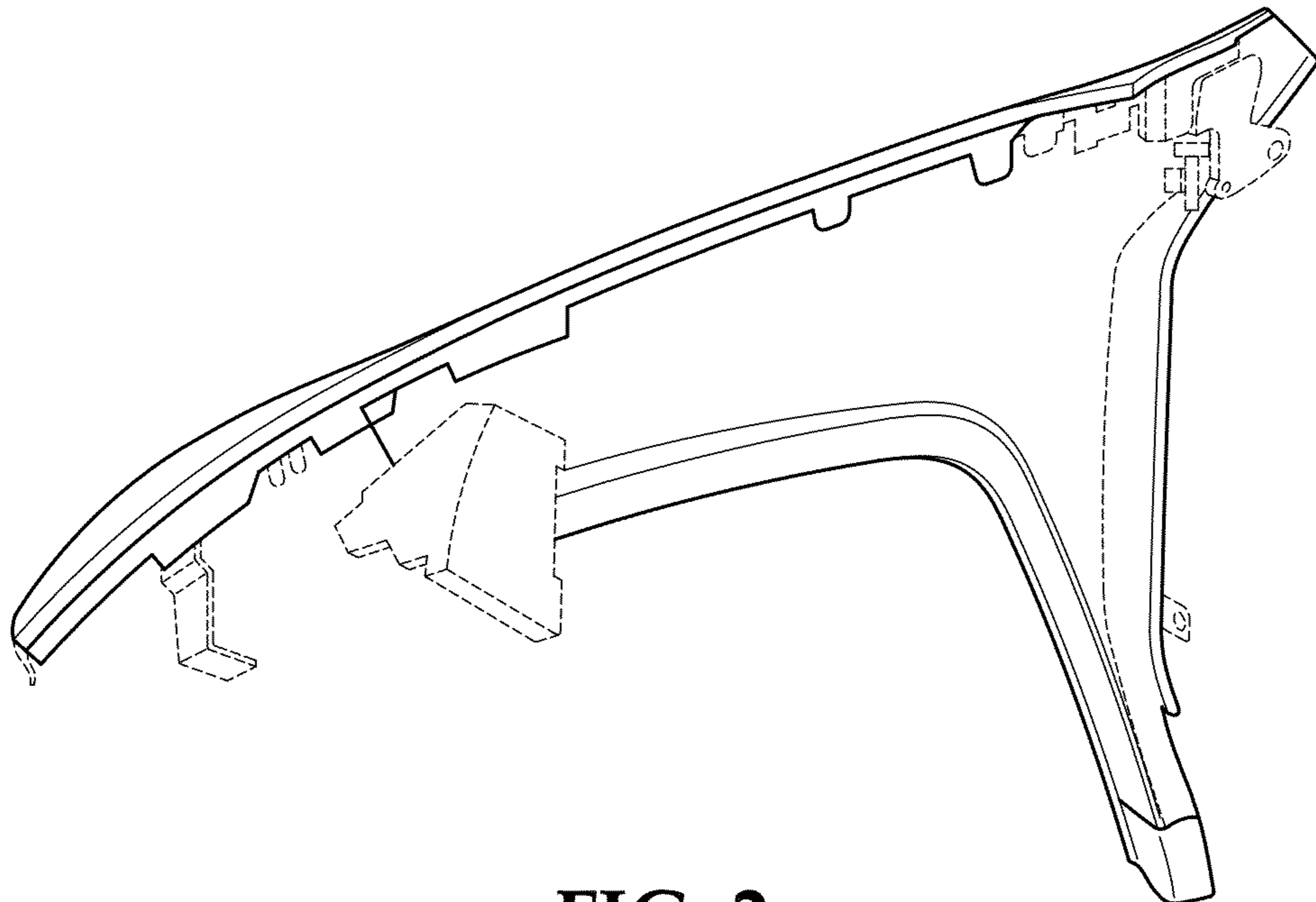

FIG. 2

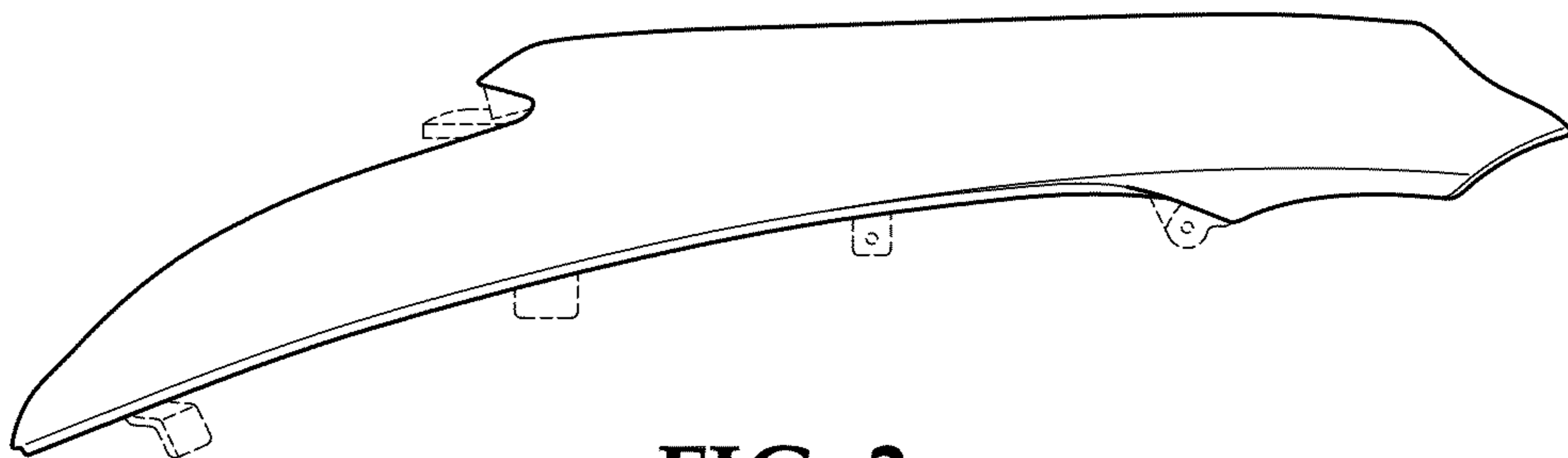

FIG. 3

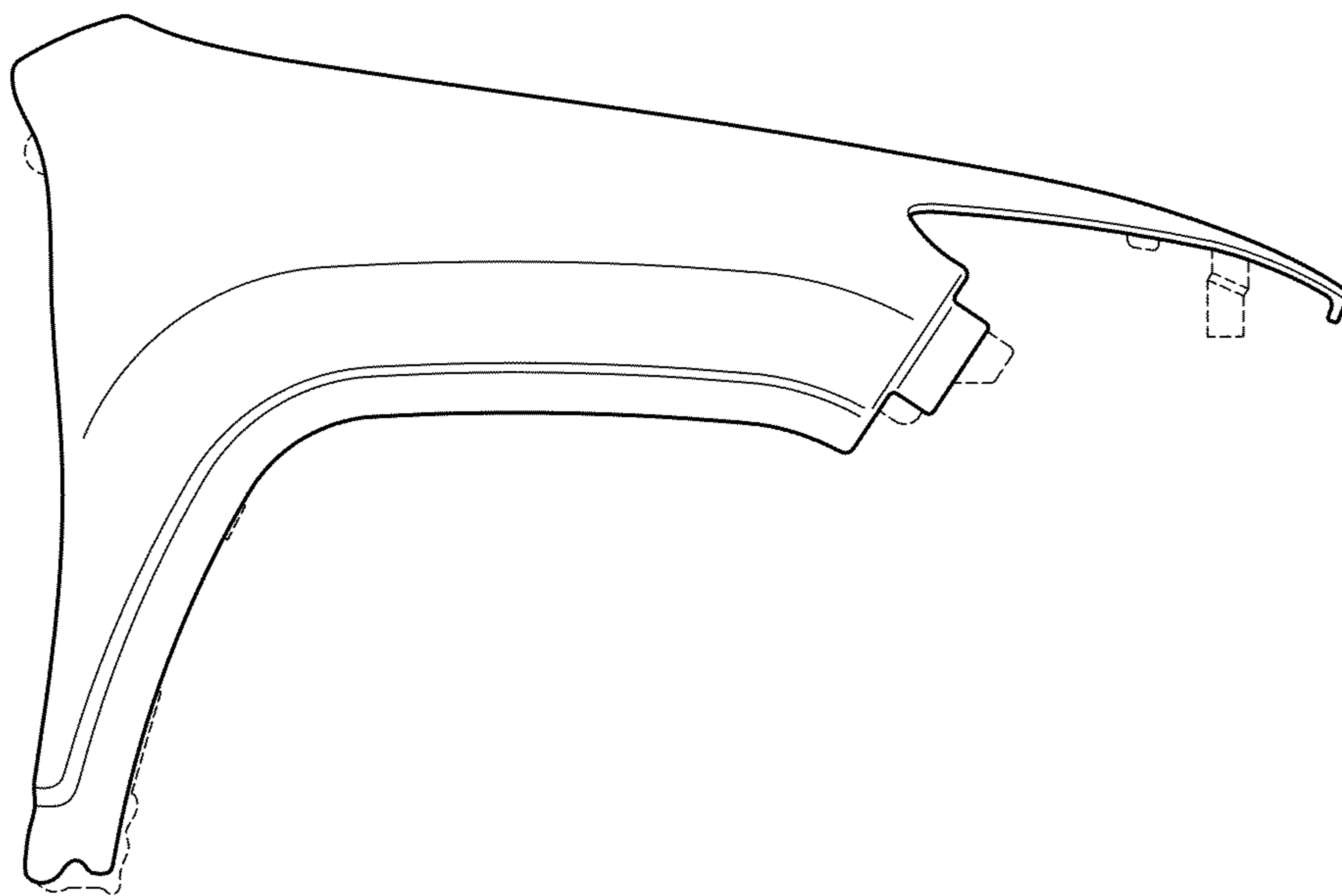

FIG. 4

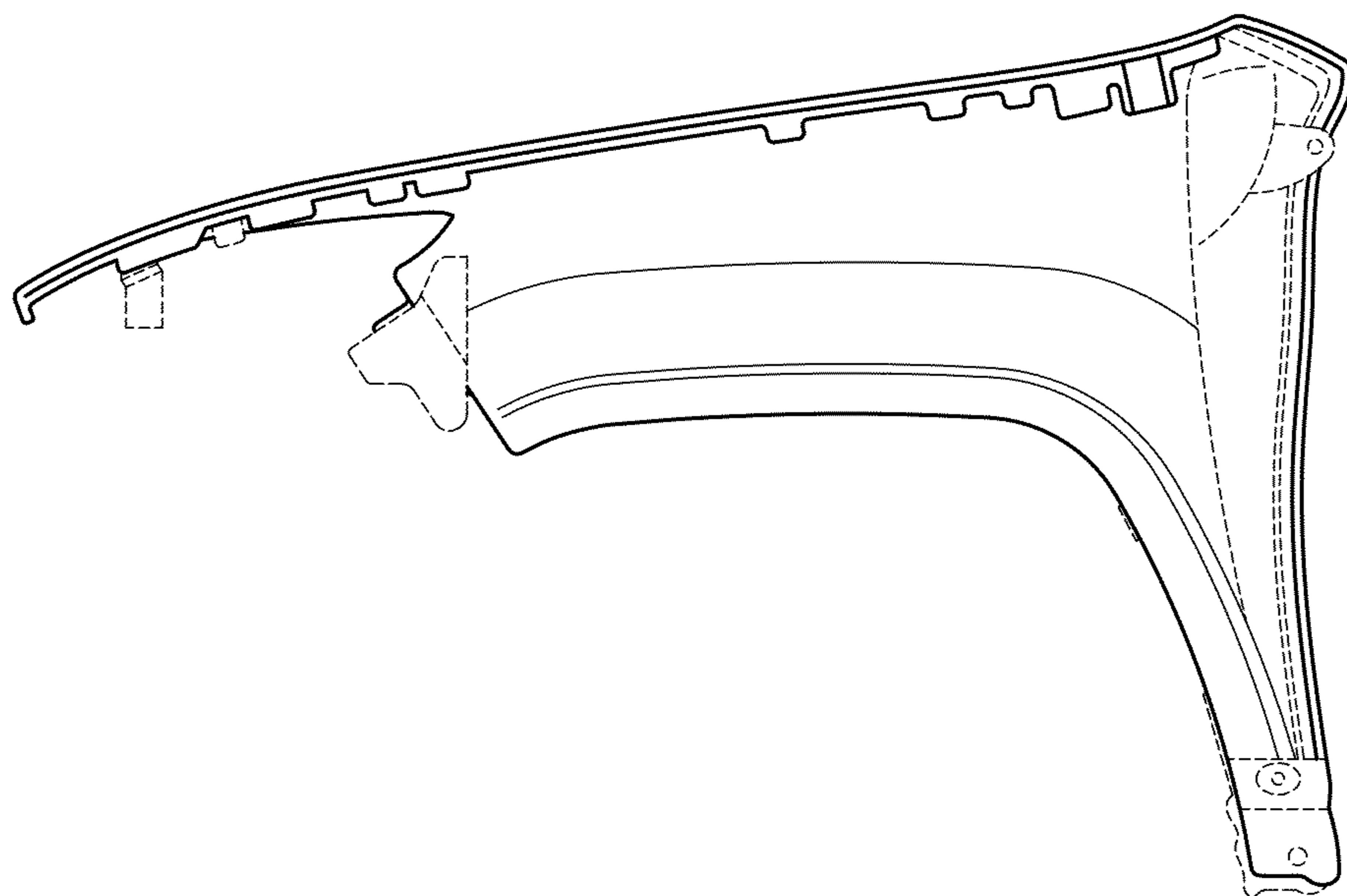

FIG. 5

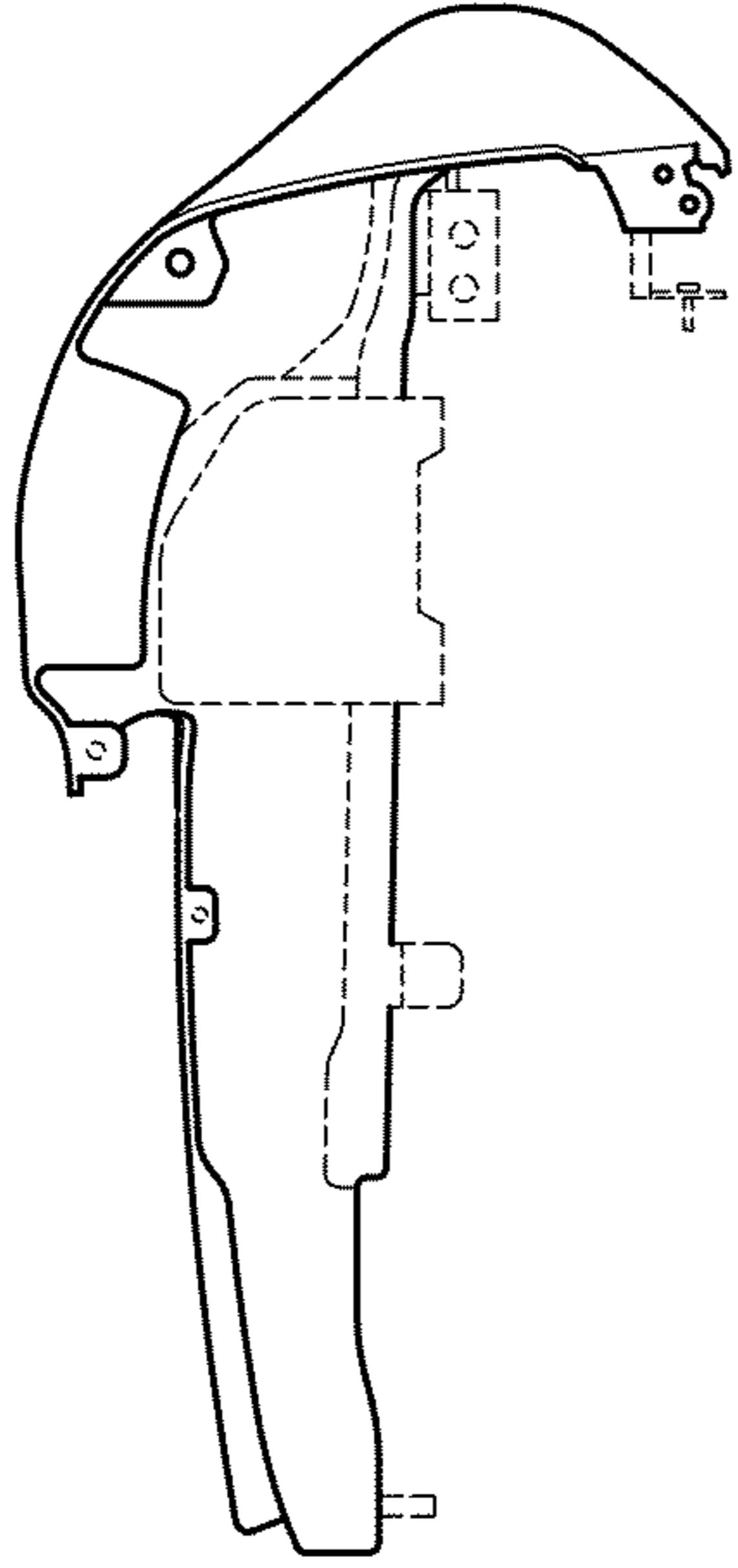

FIG. 6

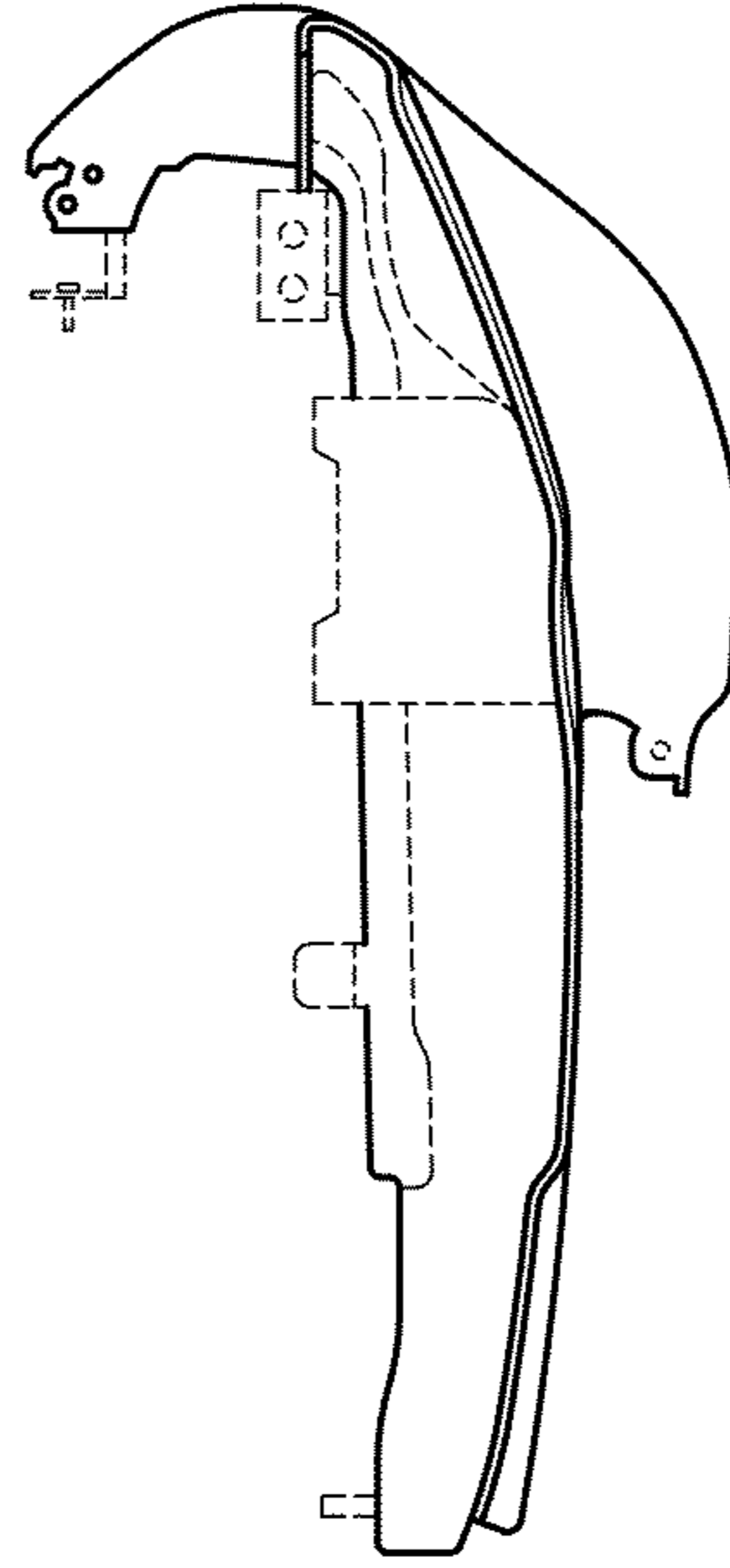

FIG. 7

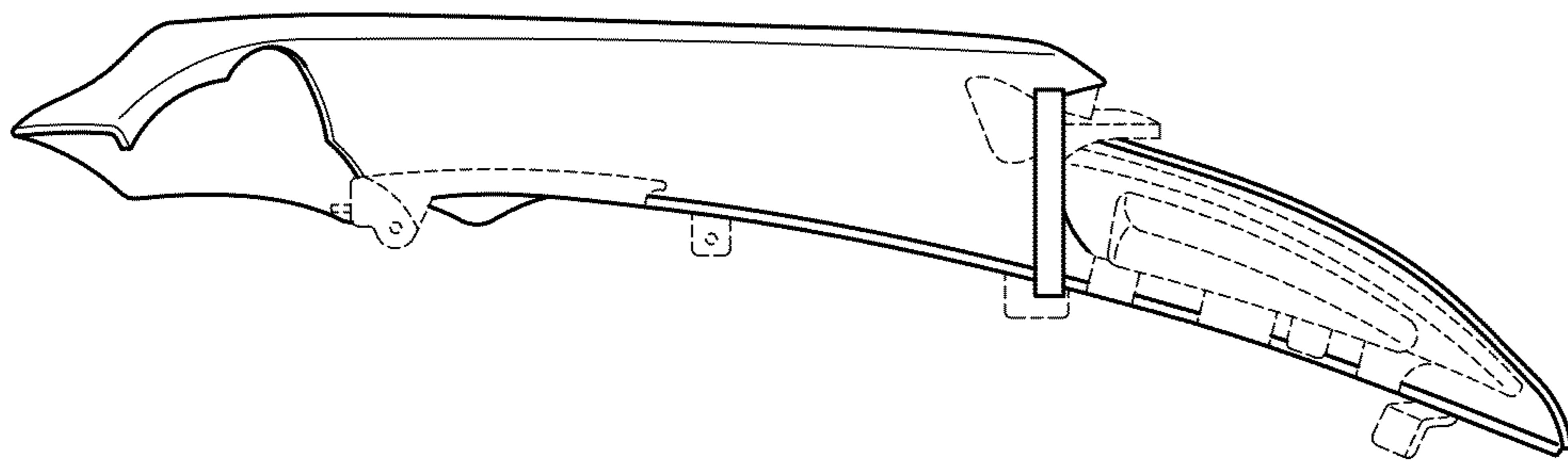

FIG. 8

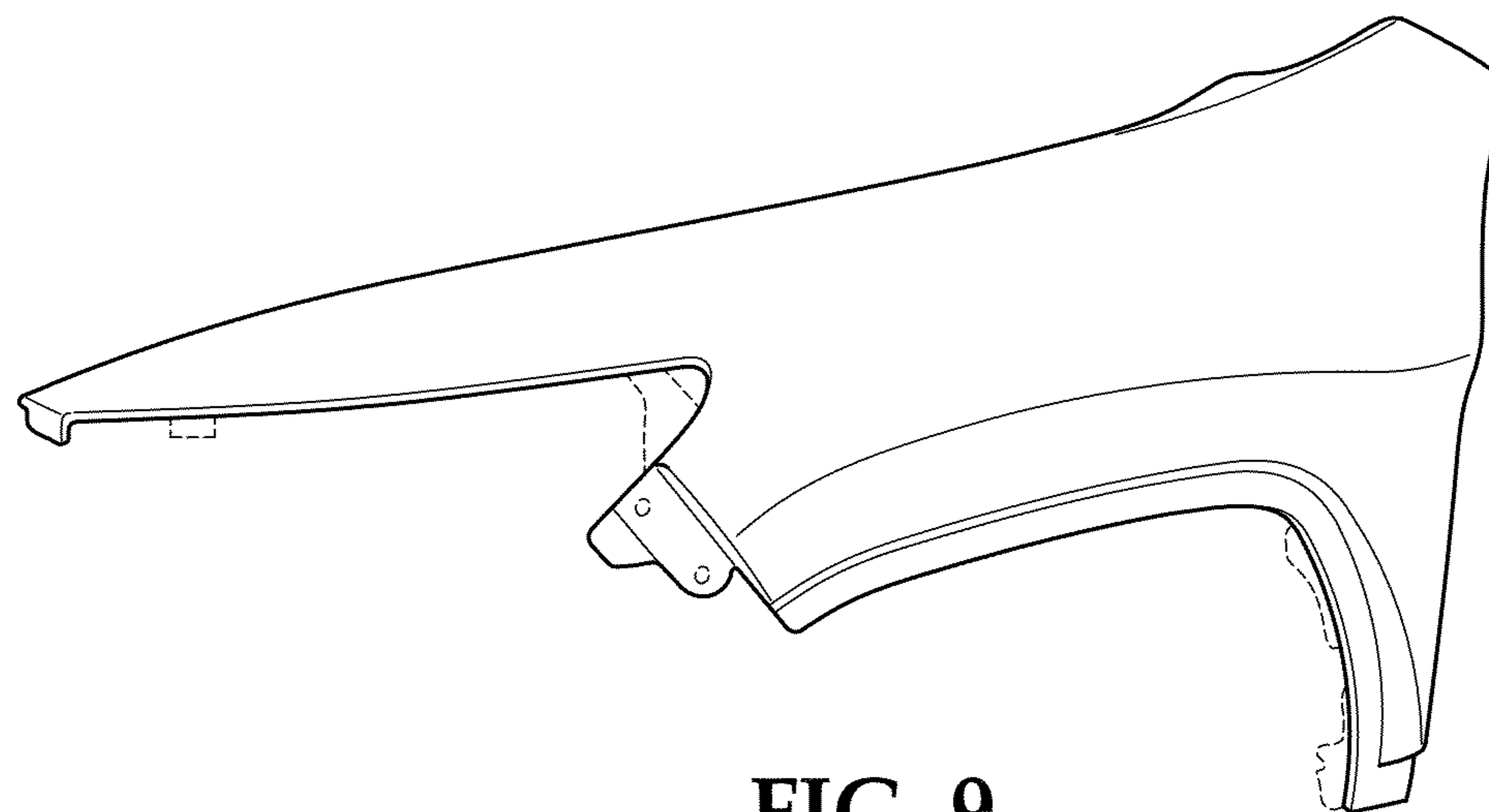

FIG. 9

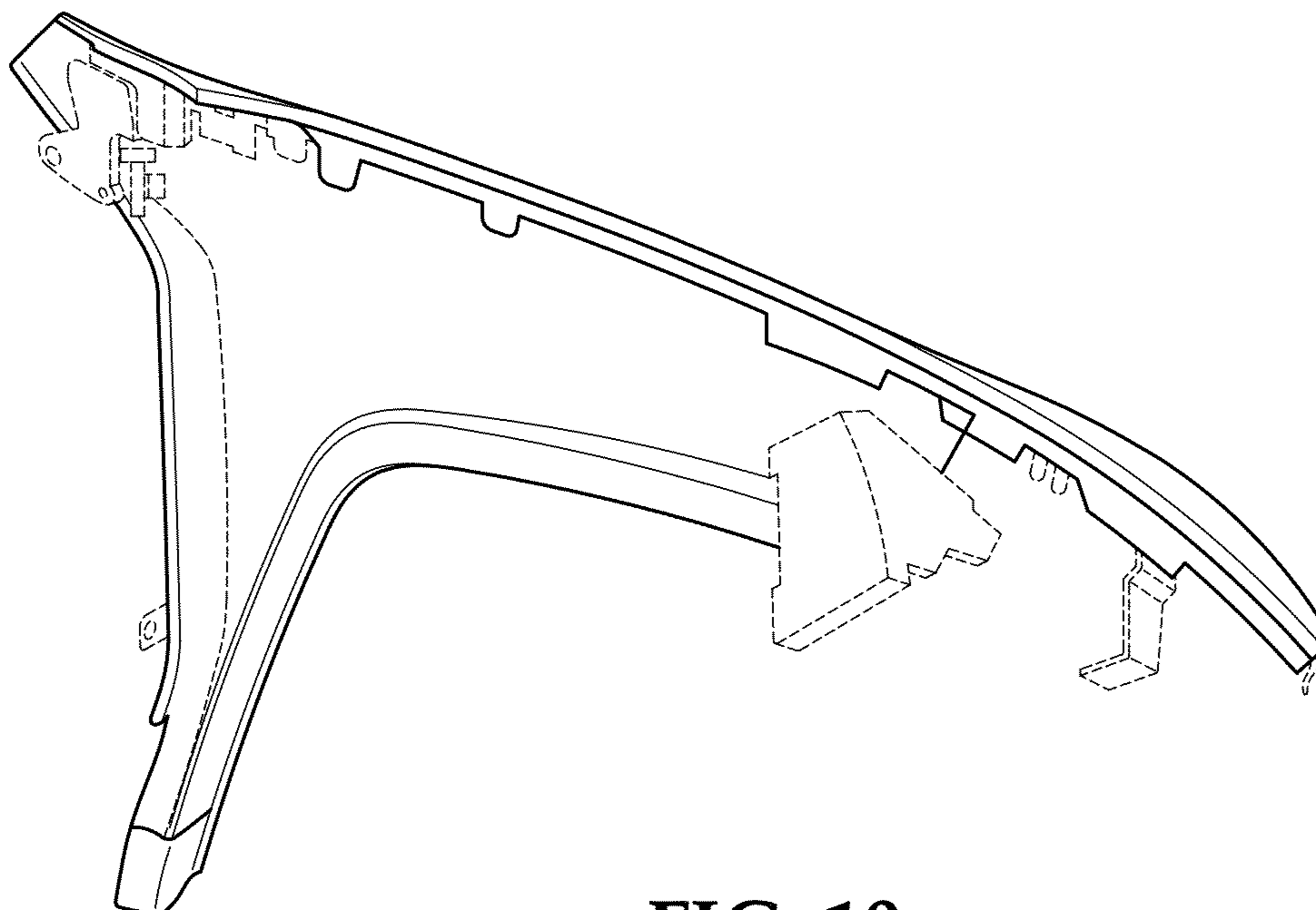

FIG. 10

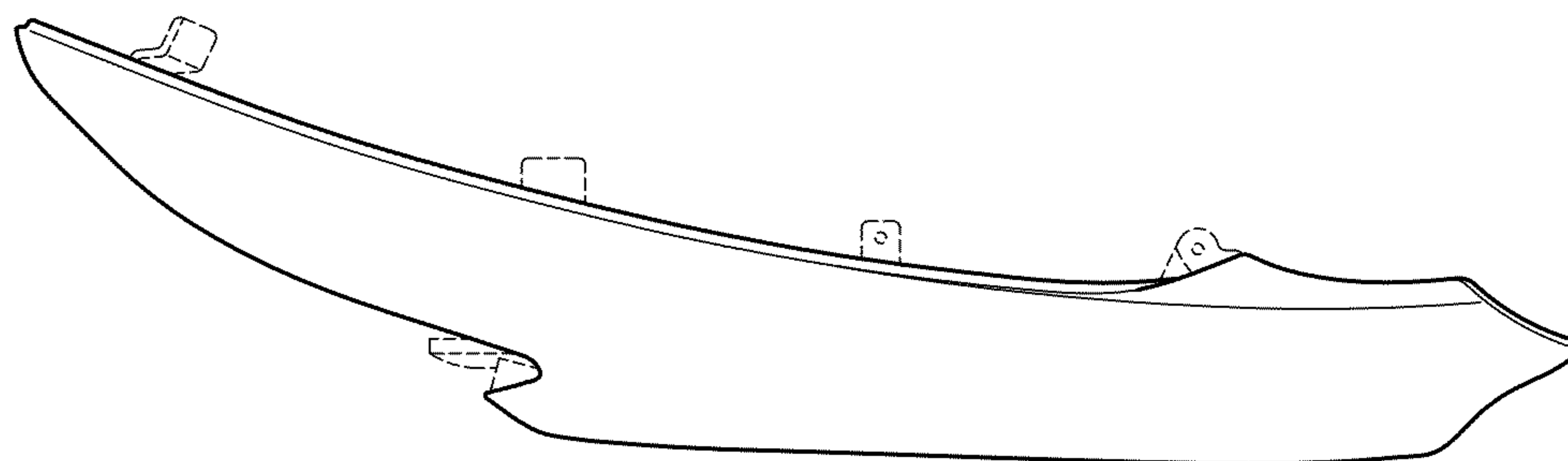

FIG. 11

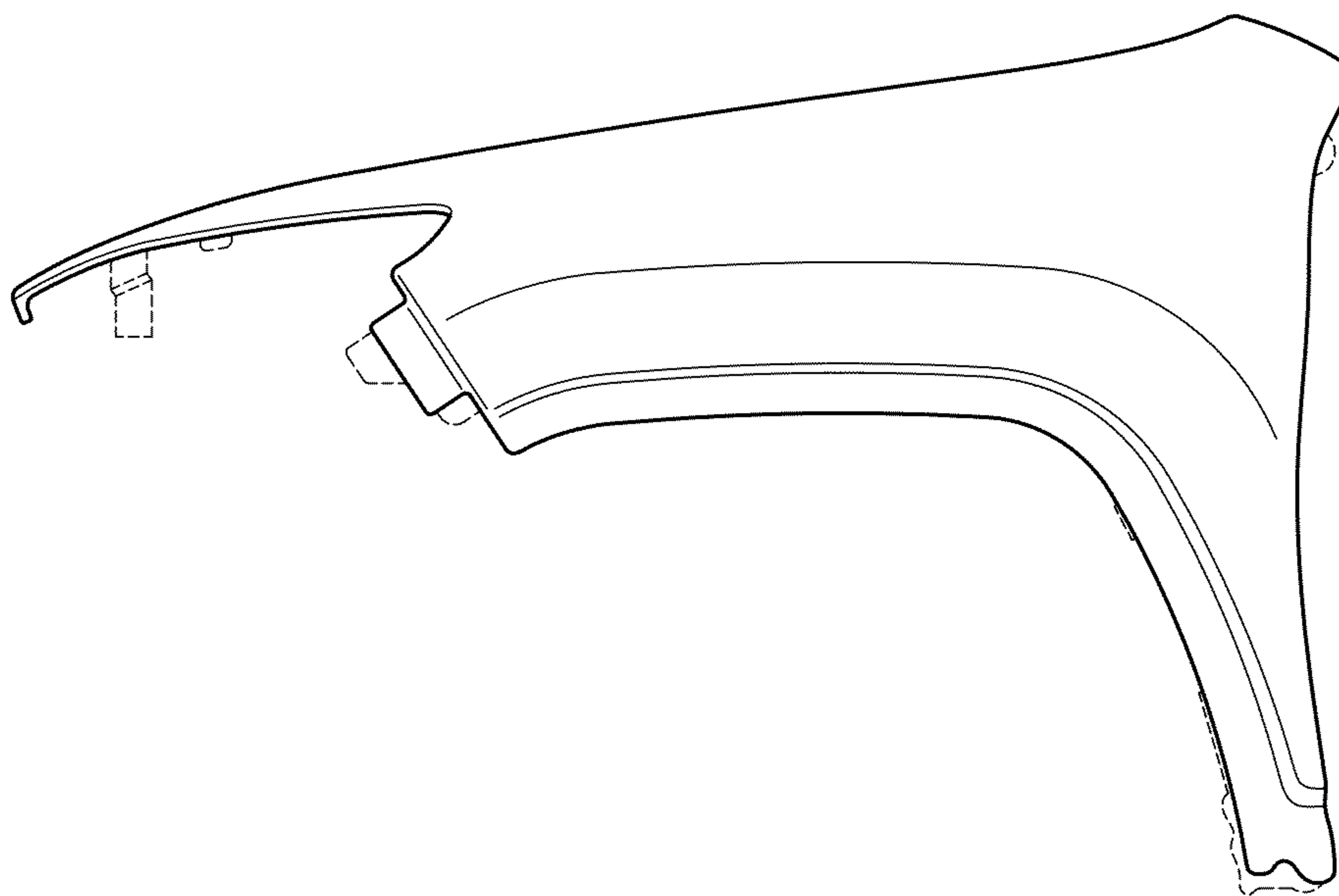

FIG. 12

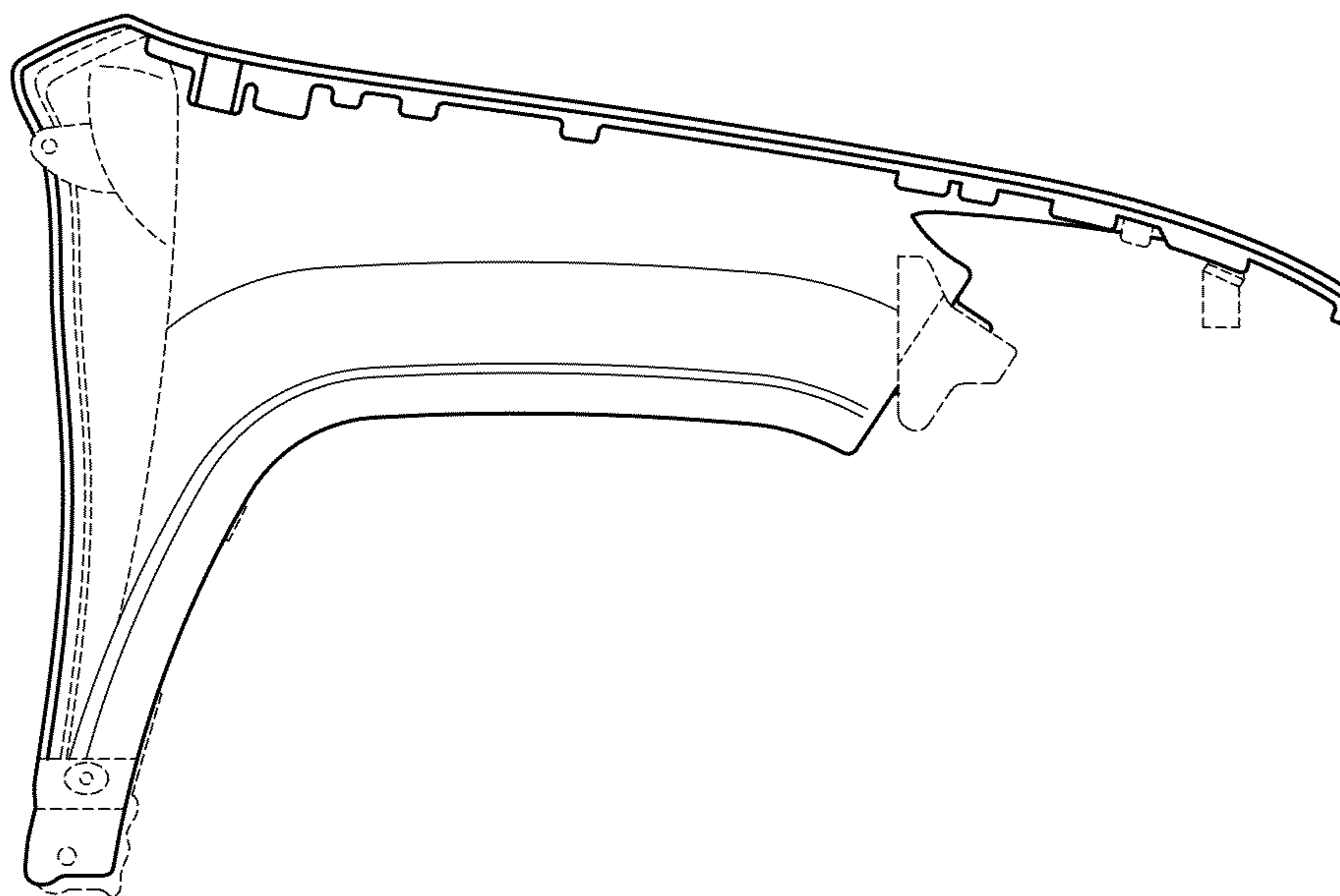

FIG. 13

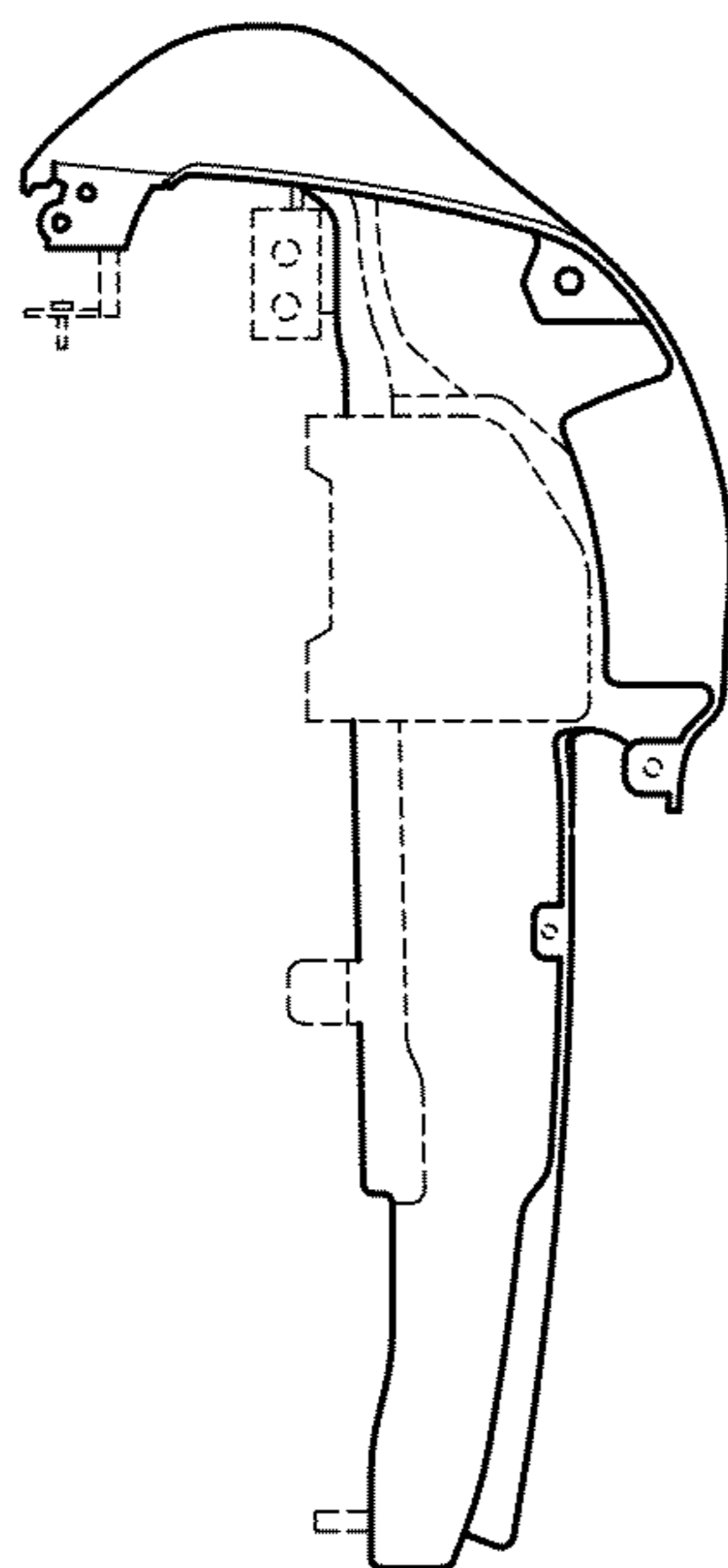

FIG. 14

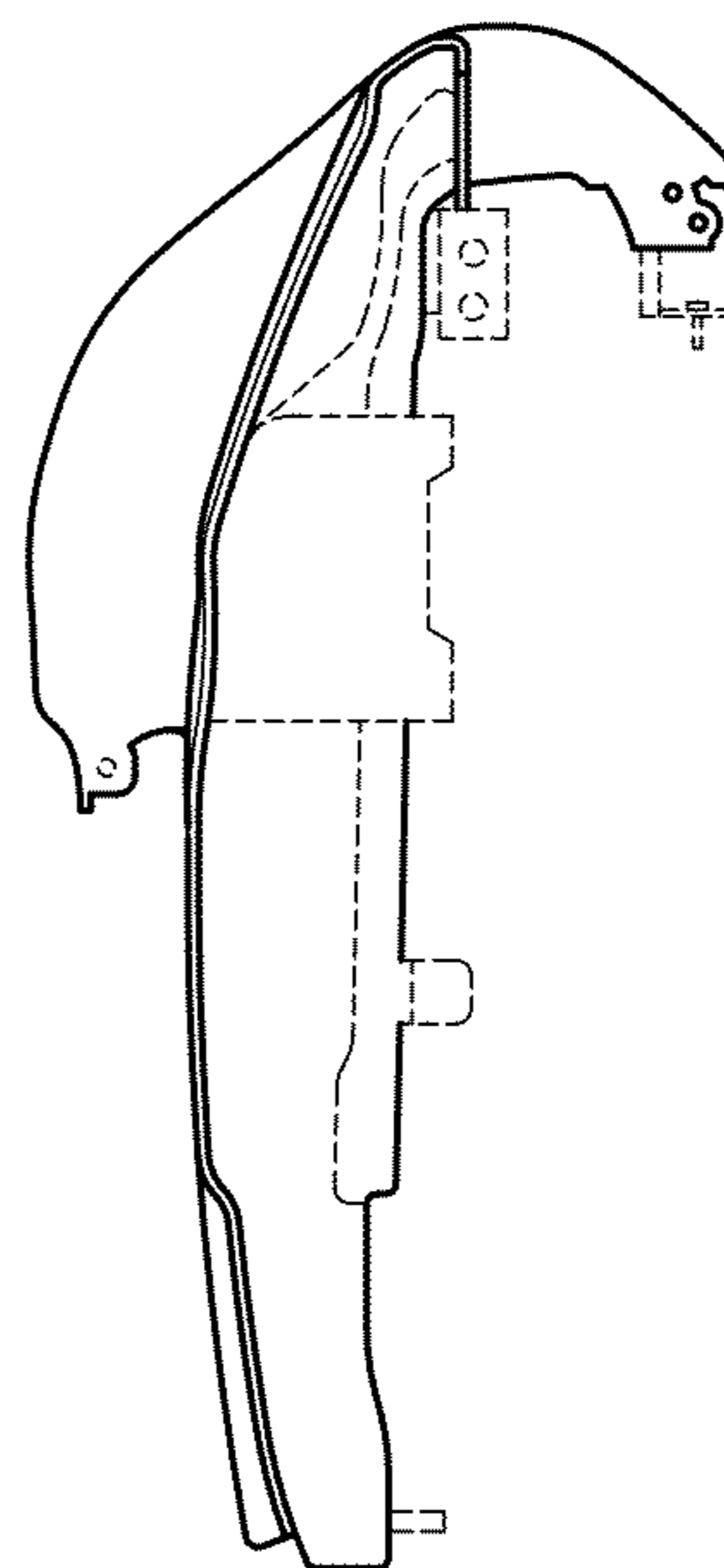

FIG. 15

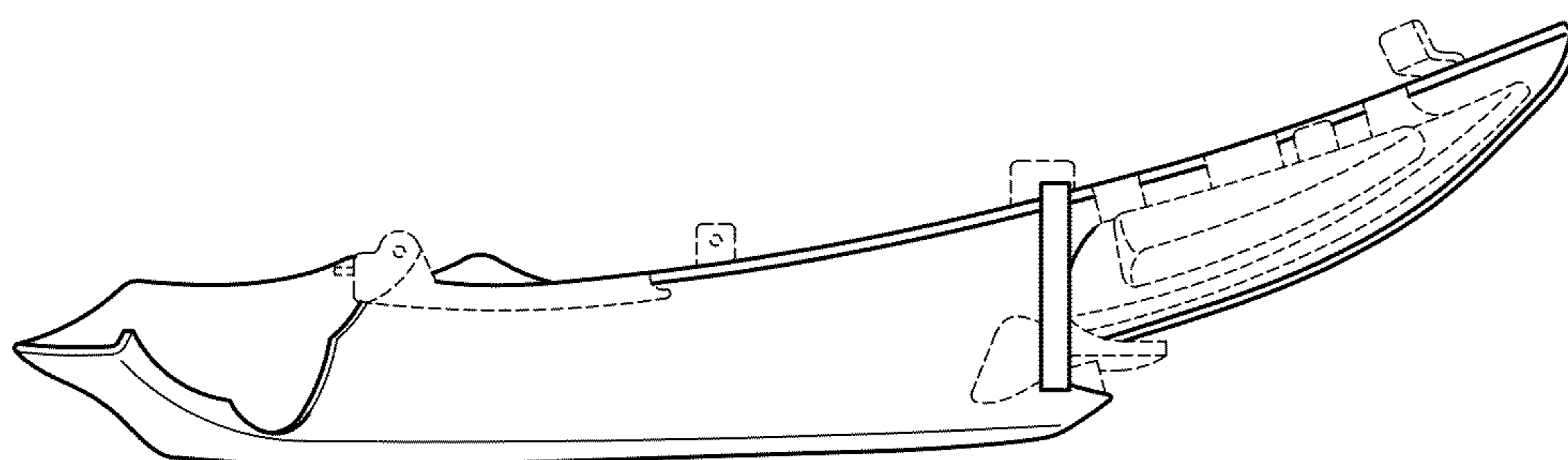

FIG. 16