



US00D731323S

(12) **United States Design Patent**
O'Neill

(10) **Patent No.:** **US D731,323 S**

(45) **Date of Patent:** **** Jun. 9, 2015**

(54) **PACKAGING**

(71) Applicant: **Rosie Colleen O'Neill**, Los Angeles, CA (US)

(72) Inventor: **Rosie Colleen O'Neill**, Los Angeles, CA (US)

(73) Assignee: **Sugarfina, LLC**, Inglewood, CA (US)

(**) Term: **14 Years**

(21) Appl. No.: **29/499,567**

(22) Filed: **Aug. 15, 2014**

(51) **LOC (10) Cl.** **09-03**

(52) **U.S. Cl.**
USPC **D9/721**

(58) **Field of Classification Search**

USPC D9/414, 415, 420, 426, 432, 433, 715, D9/721, 737, 756, 759, 761; D3/201, 205, D3/206, 273, 274, 283, 298, 290; 206/214, 206/215, 224, 318, 424, 425, 515, 518, 525, 206/575, 751-756, 758, 763, 765; 229/103, 229/116.1, 120.02, 120.06, 120.07, 120.33, 229/124, 125.01, 125.08, 125.125
CPC B65D 5/38; B65D 5/5213; B65D 5/42; B65D 5/2057; B65D 5/728; B65D 5/72; B65D 5/566; B65D 21/0233; B65D 1/36; B65D 77/02; B65D 77/0433; B65D 77/24; B65D 85/00; B65D 85/324; B65D 85/60; B65D 2543/00194; B65D 2543/00648; B65D 71/70

See application file for complete search history.

(56) **References Cited**

U.S. PATENT DOCUMENTS

228,158 A * 5/1880 Woods 206/425

1,162,840 A * 12/1915 Wood 229/125.125
1,588,857 A * 6/1926 Sherman 206/521.1
1,620,789 A * 3/1927 Urban, Jr. 229/122.21
1,994,159 A * 3/1935 Wurzburg 312/108
2,541,173 A * 2/1951 Moore 229/125.125
2,604,980 A * 7/1952 Reid 206/121
2,751,135 A * 6/1956 Kessler 229/125.125
2,790,589 A * 4/1957 Moore 229/125.125
3,423,006 A * 1/1969 Stedman 229/125.39
3,660,934 A * 5/1972 Pollack et al. 47/84
D242,771 S * 12/1976 Papillon D9/761
D603,720 S * 11/2009 Cesare et al. D9/721
7,757,843 B2 * 7/2010 Katsis 206/1.5

* cited by examiner

Primary Examiner — Derrick Holland

Assistant Examiner — Lauren Calve

(74) *Attorney, Agent, or Firm* — Paul D. Chancellor; Ocean Law

(57) **CLAIM**

The ornamental design for a packaging, substantially as shown and described.

DESCRIPTION

FIG. 1 is an exploded perspective view of a packaging showing my new design;
FIG. 2 is a perspective view thereof, shown without the packaging tray for clarity of illustration;
FIG. 3 is a side view thereof;
FIG. 4 is a top view thereof;
FIG. 5 is an end view thereof; and,
FIG. 6 is a second end view thereof.

The broken lines shown represent unclaimed subject matter and form no part of the claimed design. The shade lines shown represent surface shading and not surface ornamentation.

1 Claim, 4 Drawing Sheets

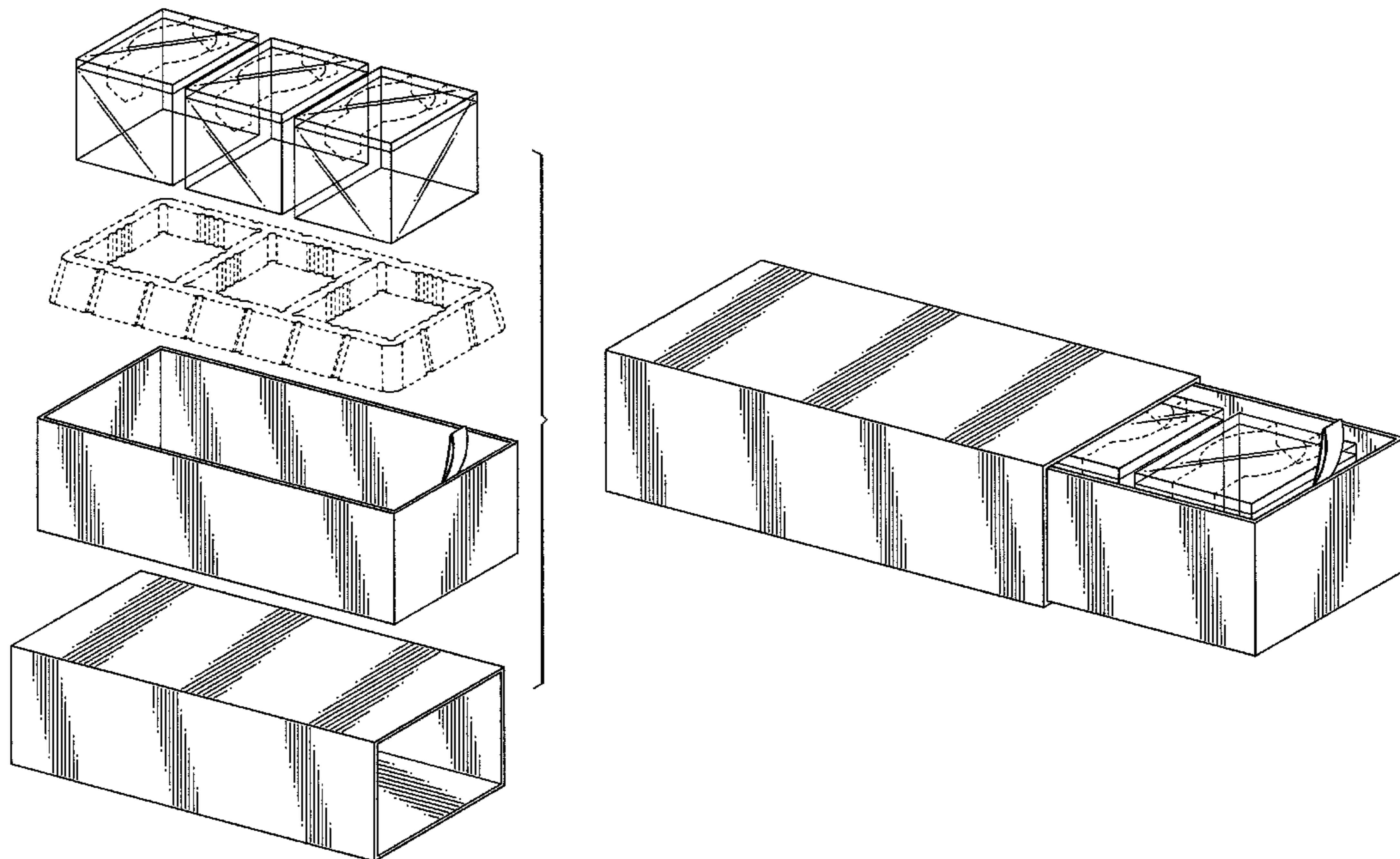

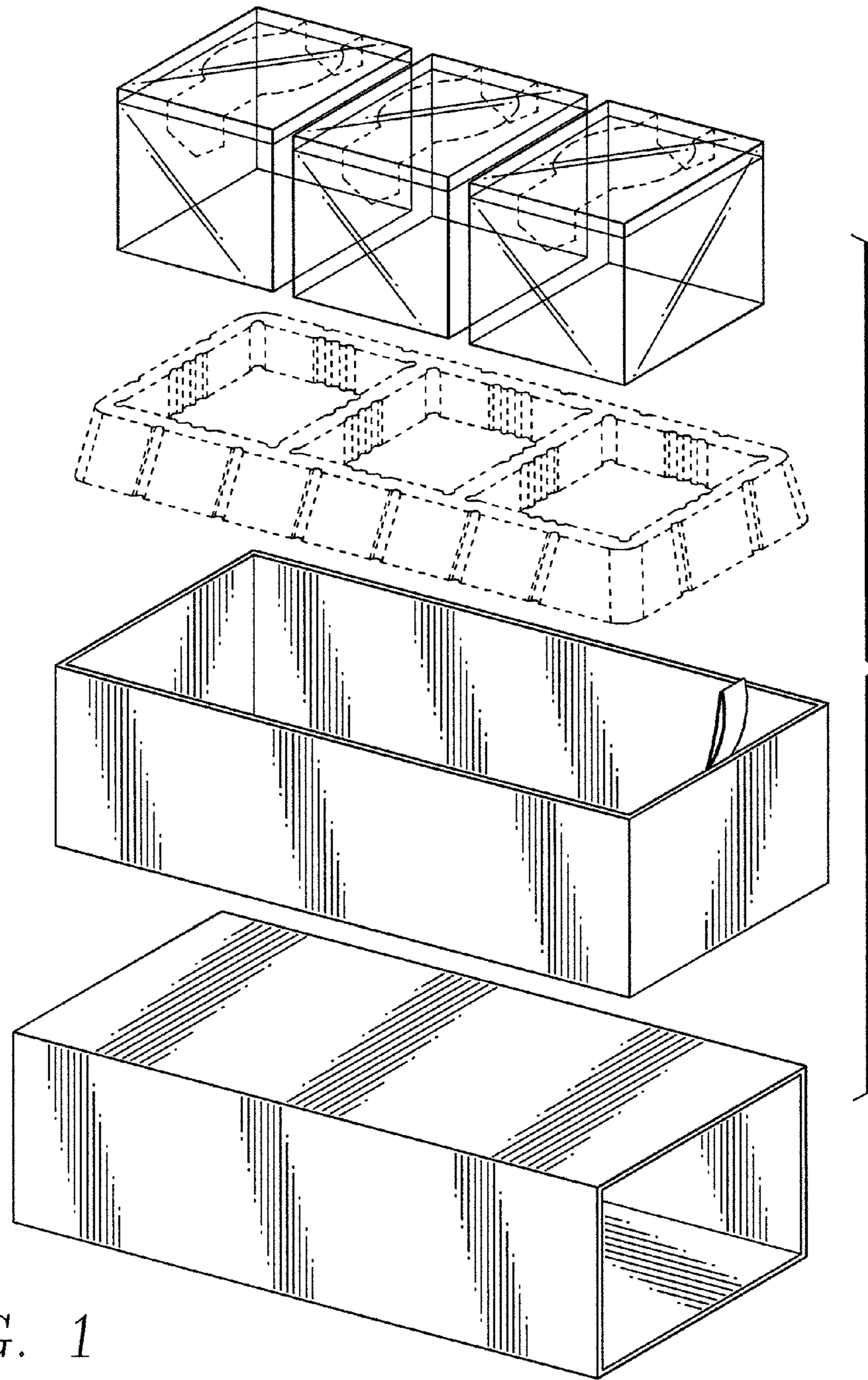

FIG. 1

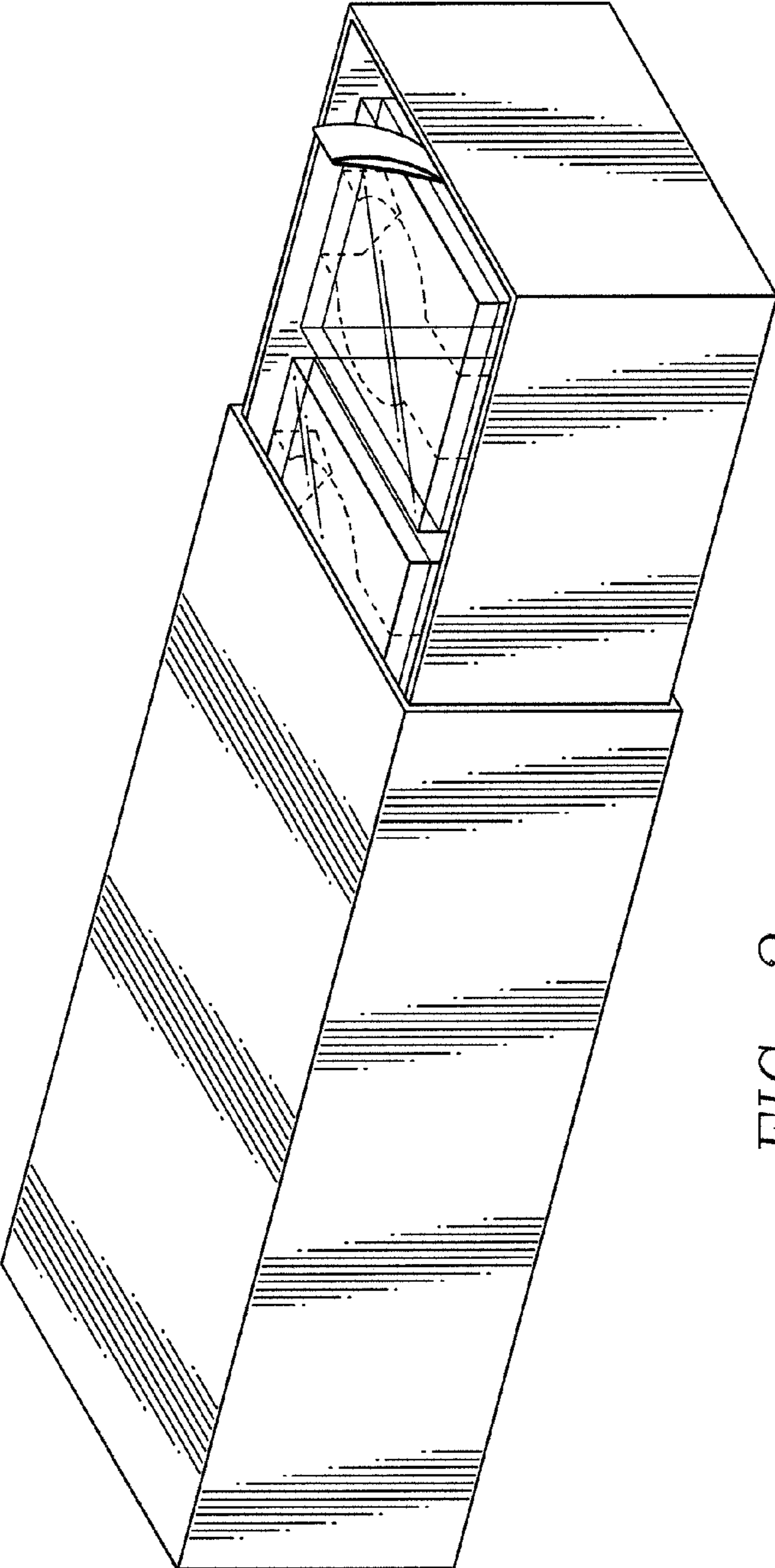

FIG. 2



FIG. 3

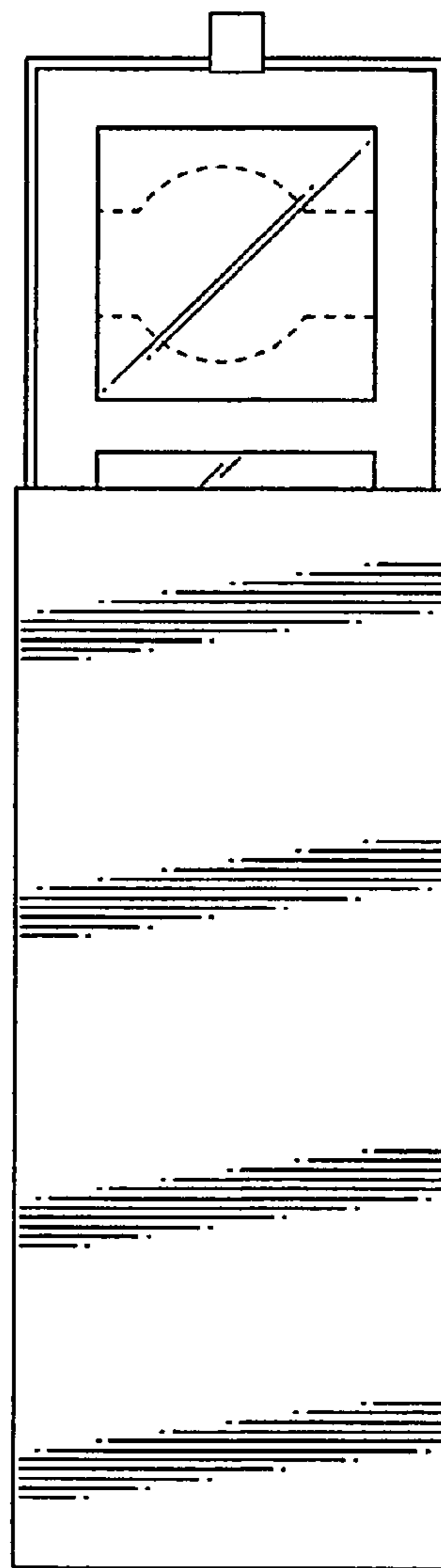

FIG. 4

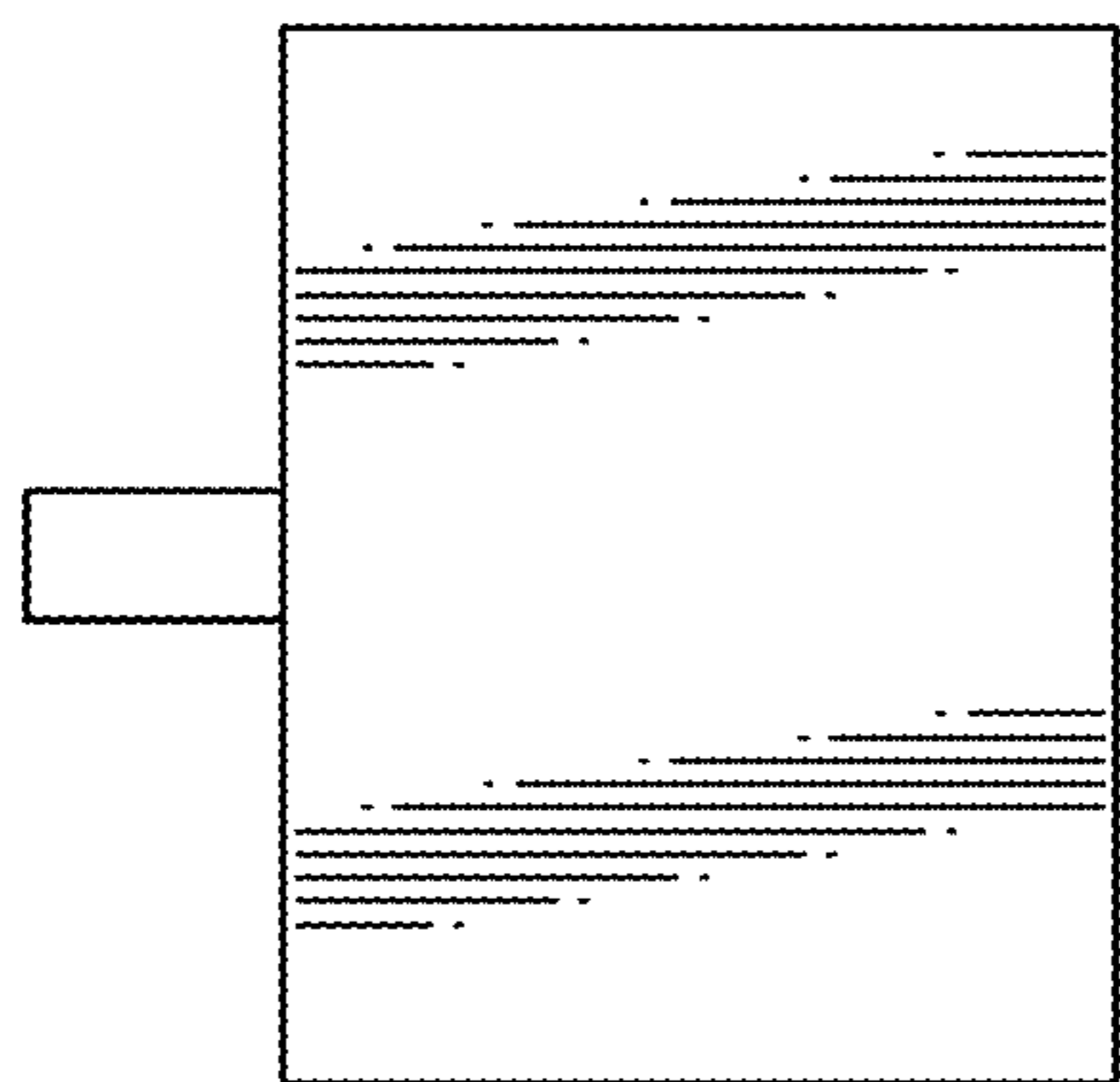

FIG. 6

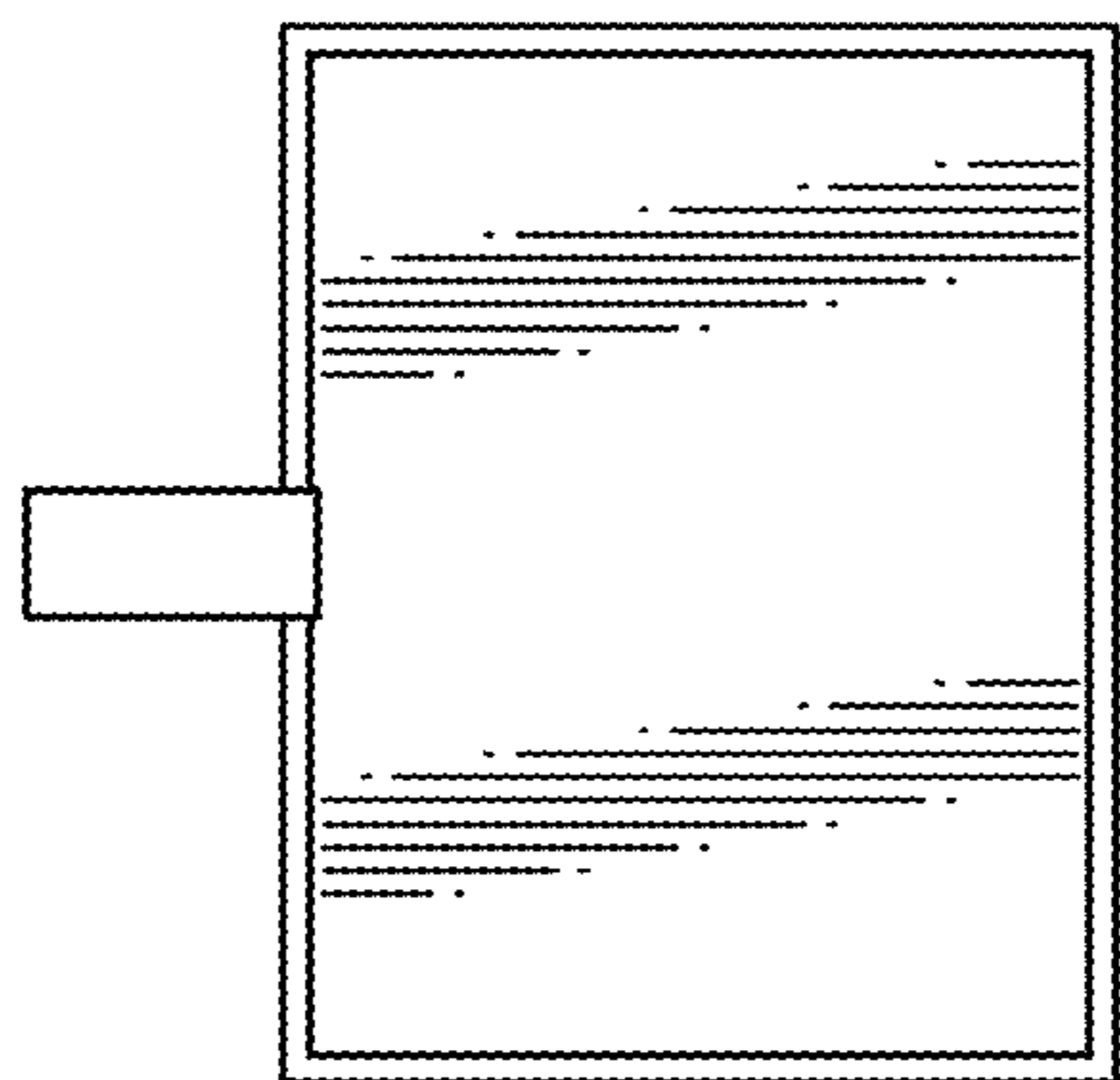

FIG. 5