



US00D731193S

(12) **United States Design Patent**  
**Zuber et al.**

(10) **Patent No.:** **US D731,193 S**  
(45) **Date of Patent:** **\*\* Jun. 9, 2015**

(54) **AIRCRAFT SEAT**

(71) Applicant: **Airbus Corporate Jet Centre**, Blagnac (FR)

(72) Inventors: **Antoine Zuber**, Blagnac (FR); **Sylvain Mariat**, Blagnac (FR)

(73) Assignee: **Airbus Corporate Jet Centre**, Blagnac (FR)

(\*\*) Term: **14 Years**

(21) Appl. No.: **29/470,611**

(22) Filed: **Oct. 23, 2013**

(30) **Foreign Application Priority Data**

May 21, 2013 (EM) ..... 001371793-0001

(51) **LOC (10) Cl.** ..... **06-01**

(52) **U.S. Cl.**  
USPC ..... **D6/356**

(58) **Field of Classification Search**  
USPC ..... D6/334-336, 356, 361, 364, 365, 367,  
D6/374, 375, 381, 716, 716.1, 716.2,  
D6/716.3, 716.4, 717  
CPC ..... B64D 11/06; B64D 11/00; A47C 1/032;  
B60N 2/34; B60N 2/22

See application file for complete search history.

(56) **References Cited**

U.S. PATENT DOCUMENTS

D273,157 S *	3/1984	Staub .....	D6/356
5,107,720 A *	4/1992	Hatfield .....	A47C 1/032
5,333,818 A *	8/1994	Brandt et al. ....	B64D 11/00
D364,508 S *	11/1995	Pryor et al. ....	D6/356
D411,922 S *	7/1999	Granados .....	D6/356
D577,503 S *	9/2008	Priestman .....	D6/356
D703,964 S *	5/2014	Gagnon et al. ....	D6/356

\* cited by examiner

*Primary Examiner* — Mimoso De

(74) *Attorney, Agent, or Firm* — Greer, Burns & Crain, Ltd.

(57) **CLAIM**

The ornamental design for an aircraft seat, as shown and described.

**DESCRIPTION**

FIG. 1 is a front and side perspective view of an aircraft seat; FIG. 2 is a front and opposite side perspective view thereof; FIG. 3 is a rear and side perspective view thereof; FIG. 4 is a side elevational view thereof; FIG. 5 is a top plan view thereof; FIG. 6 is an opposite side elevational view thereof; FIG. 7 is a front elevational view thereof; and, FIG. 8 is a rear elevational view thereof. The broken lines in FIGS. 1-8 represent portions of the aircraft seat that form no part of the claimed design. The bottom view forms no part of the claimed design.

**1 Claim, 8 Drawing Sheets**

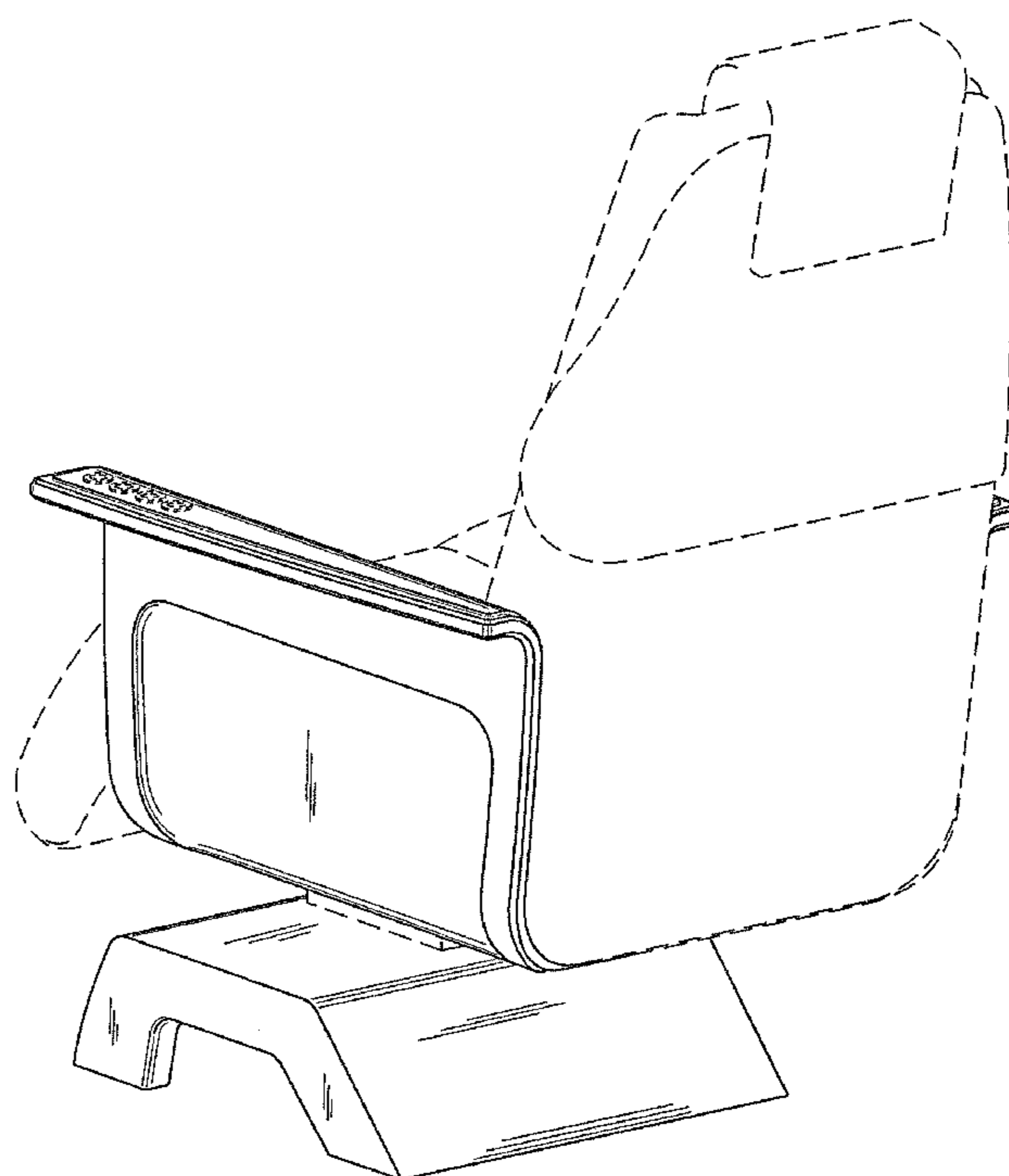
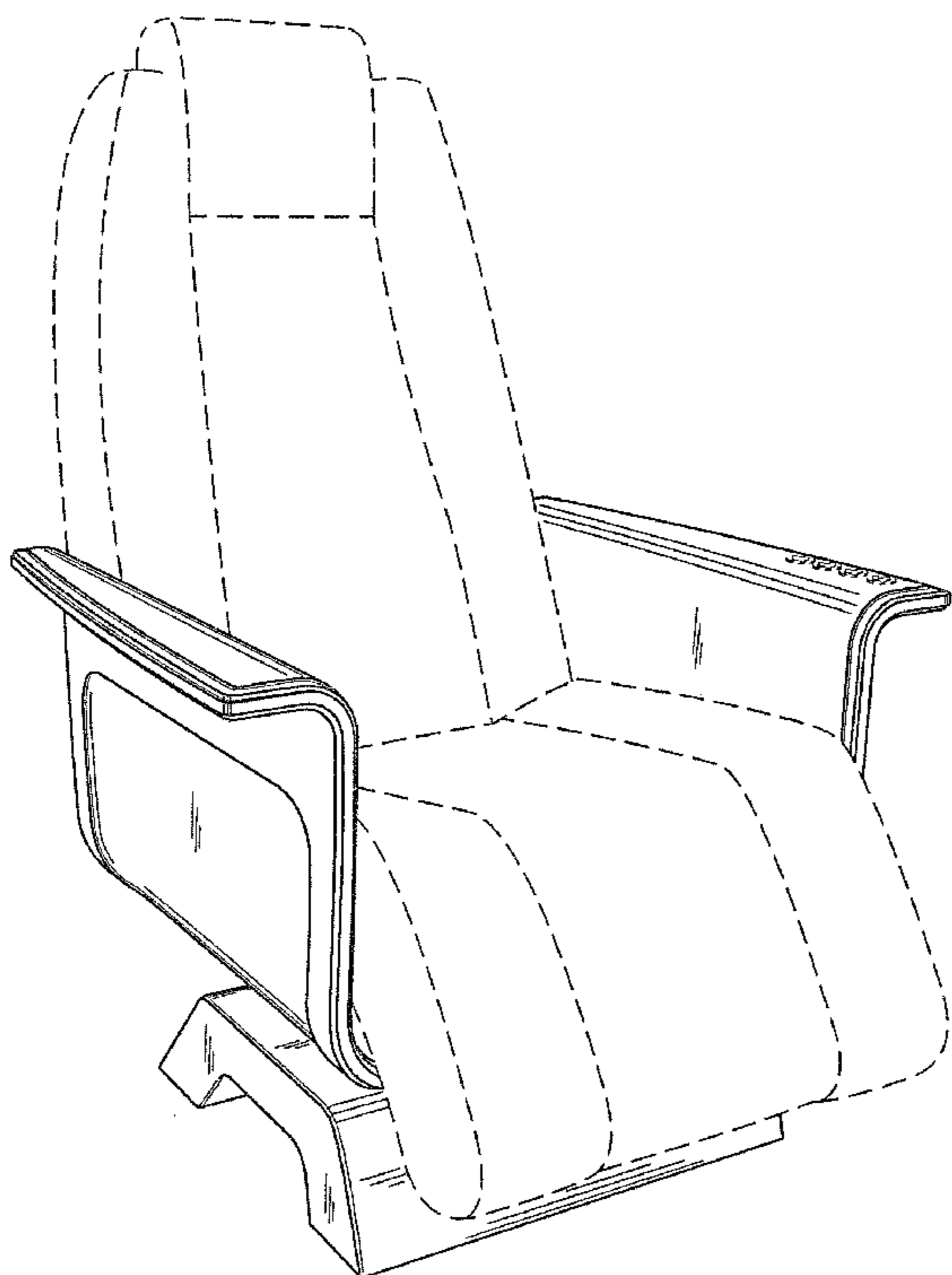

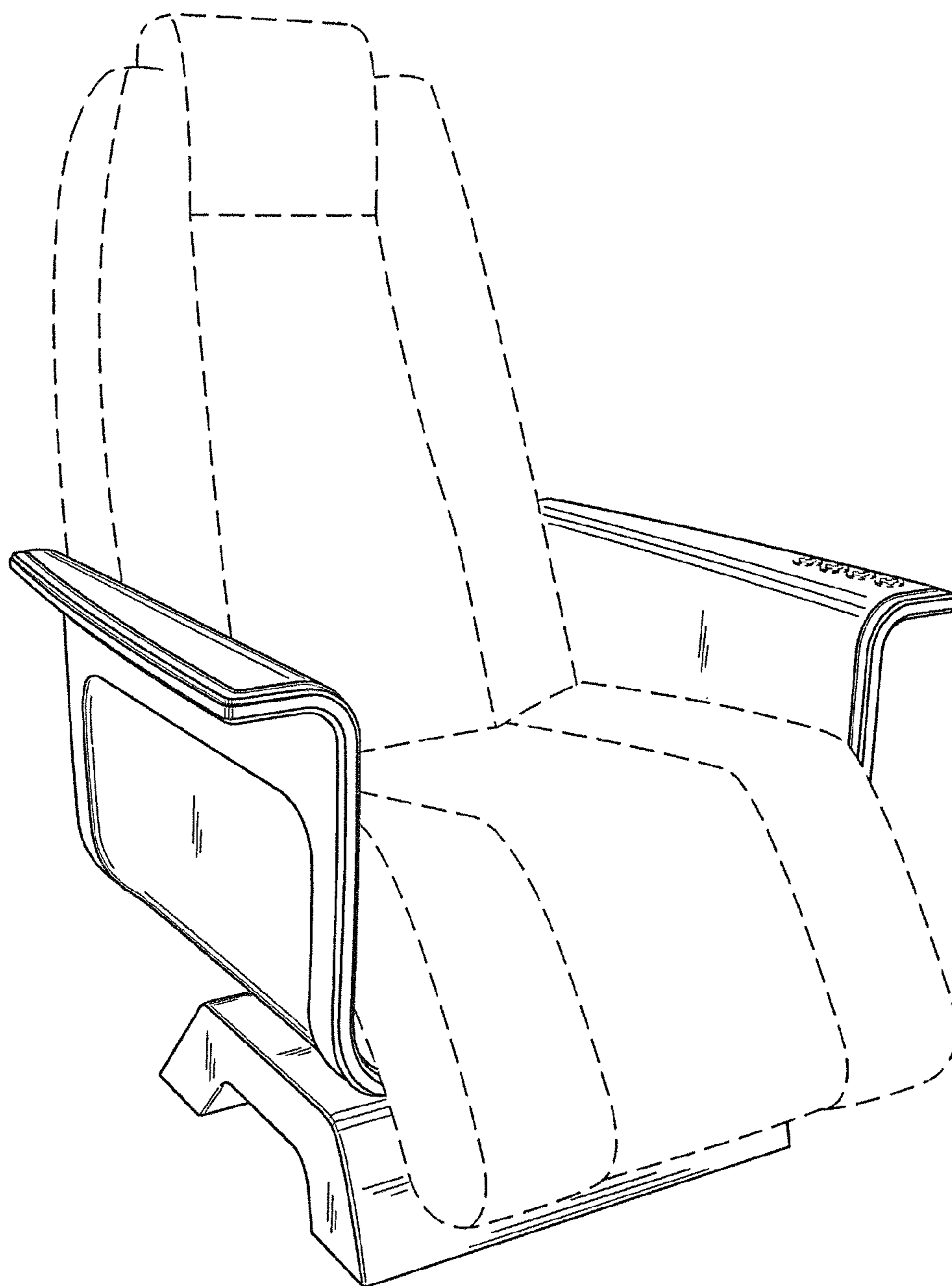

Fig. 1

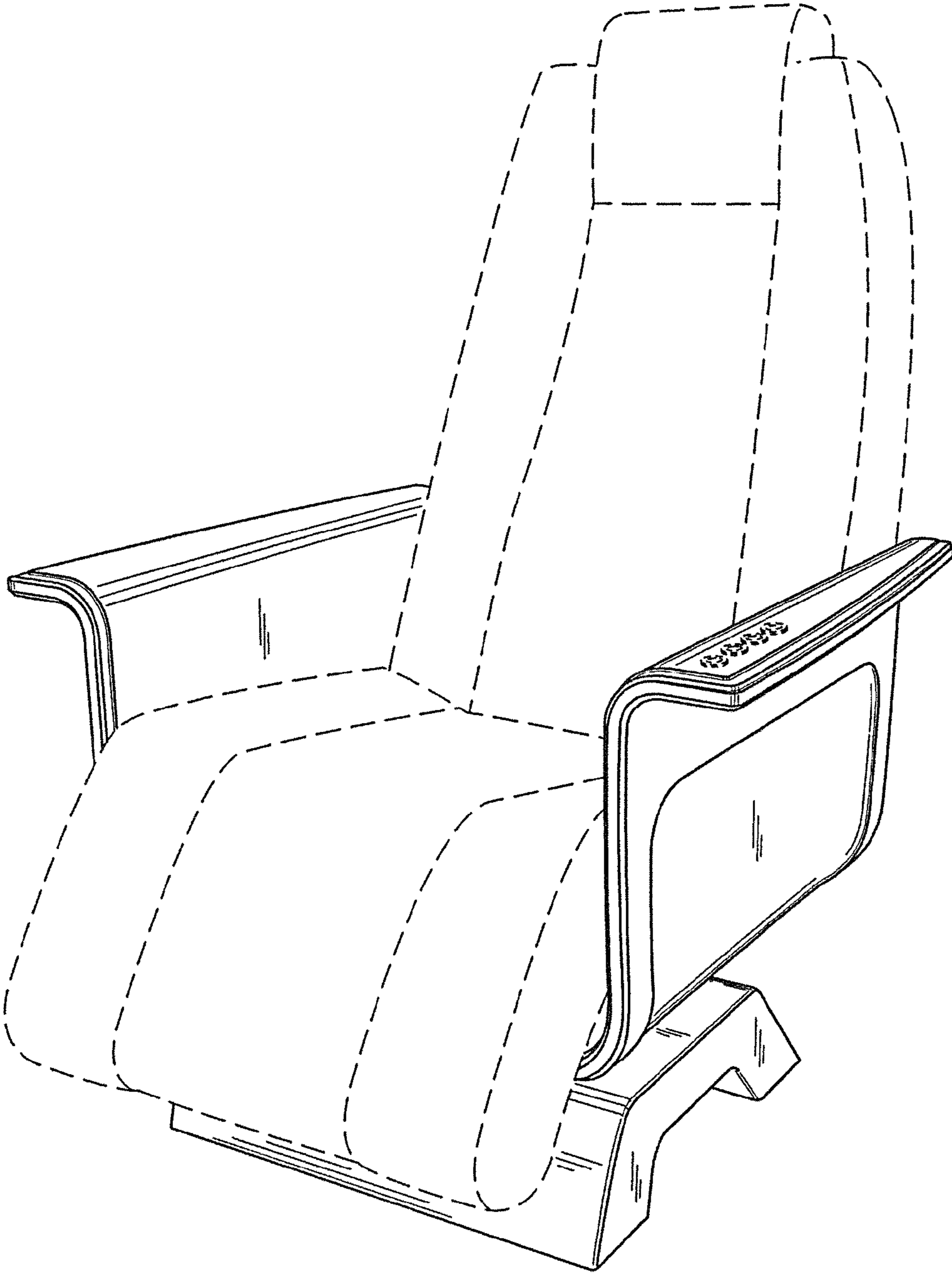

Fig. 2

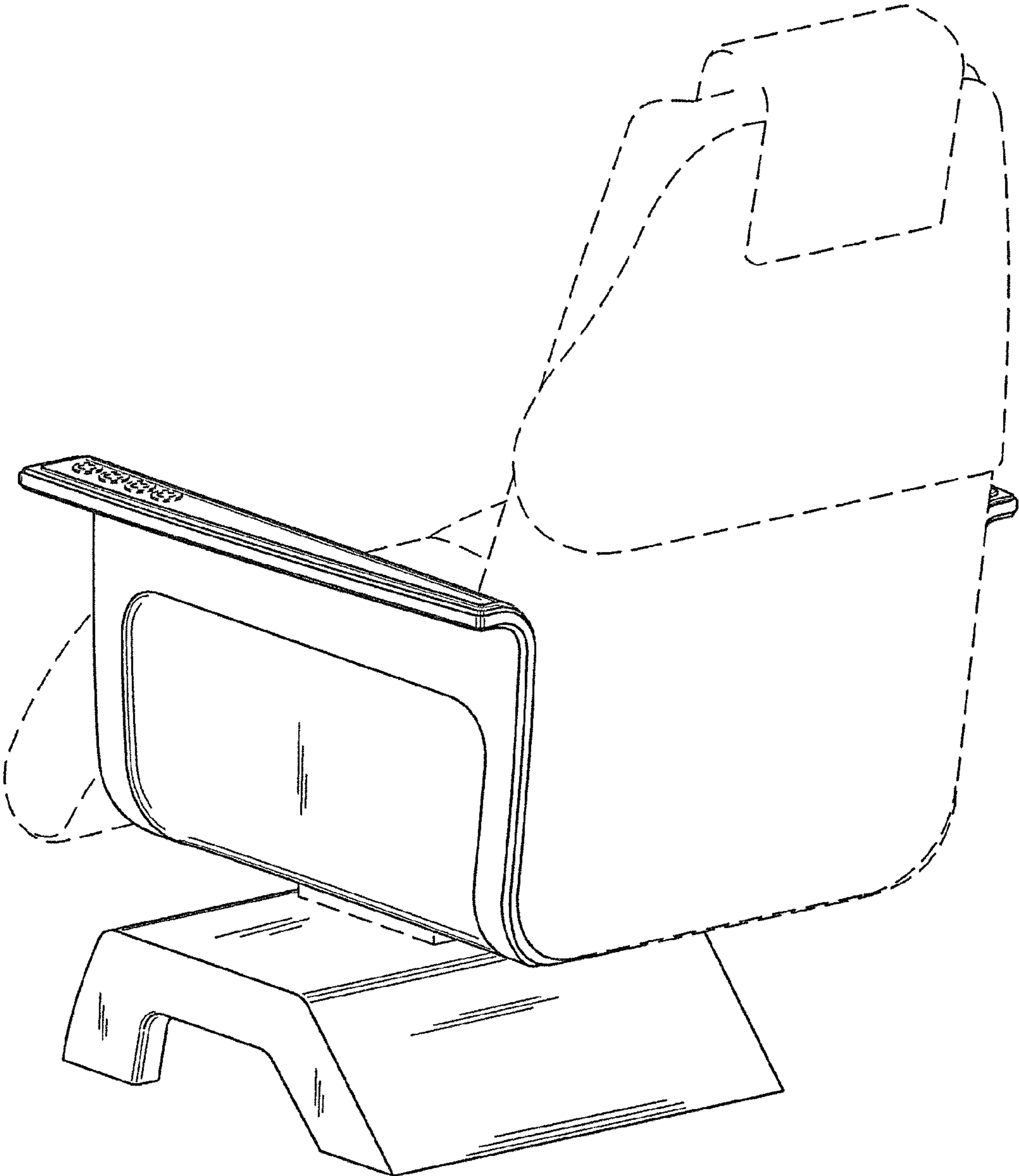

Fig. 3

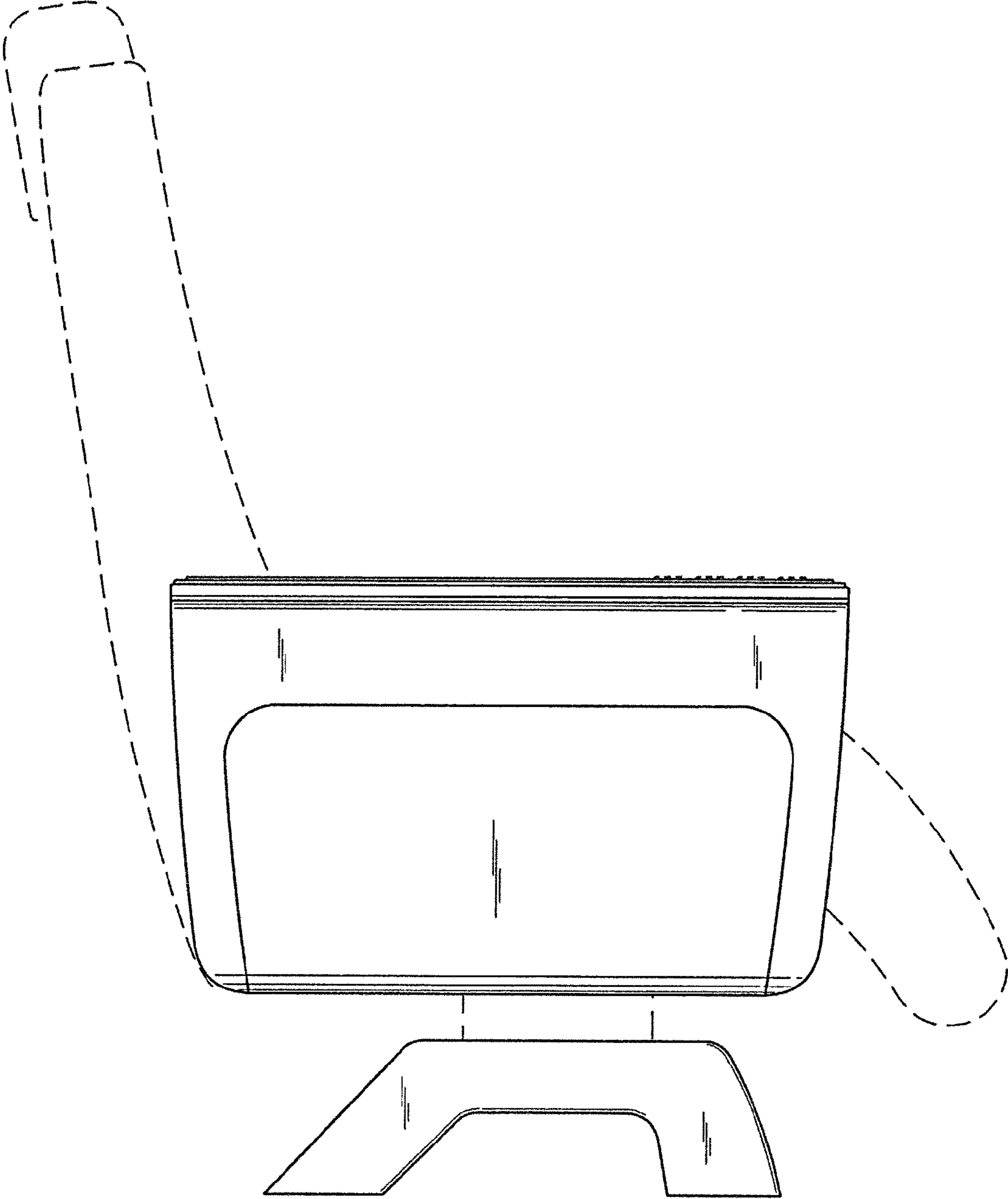

Fig. 4

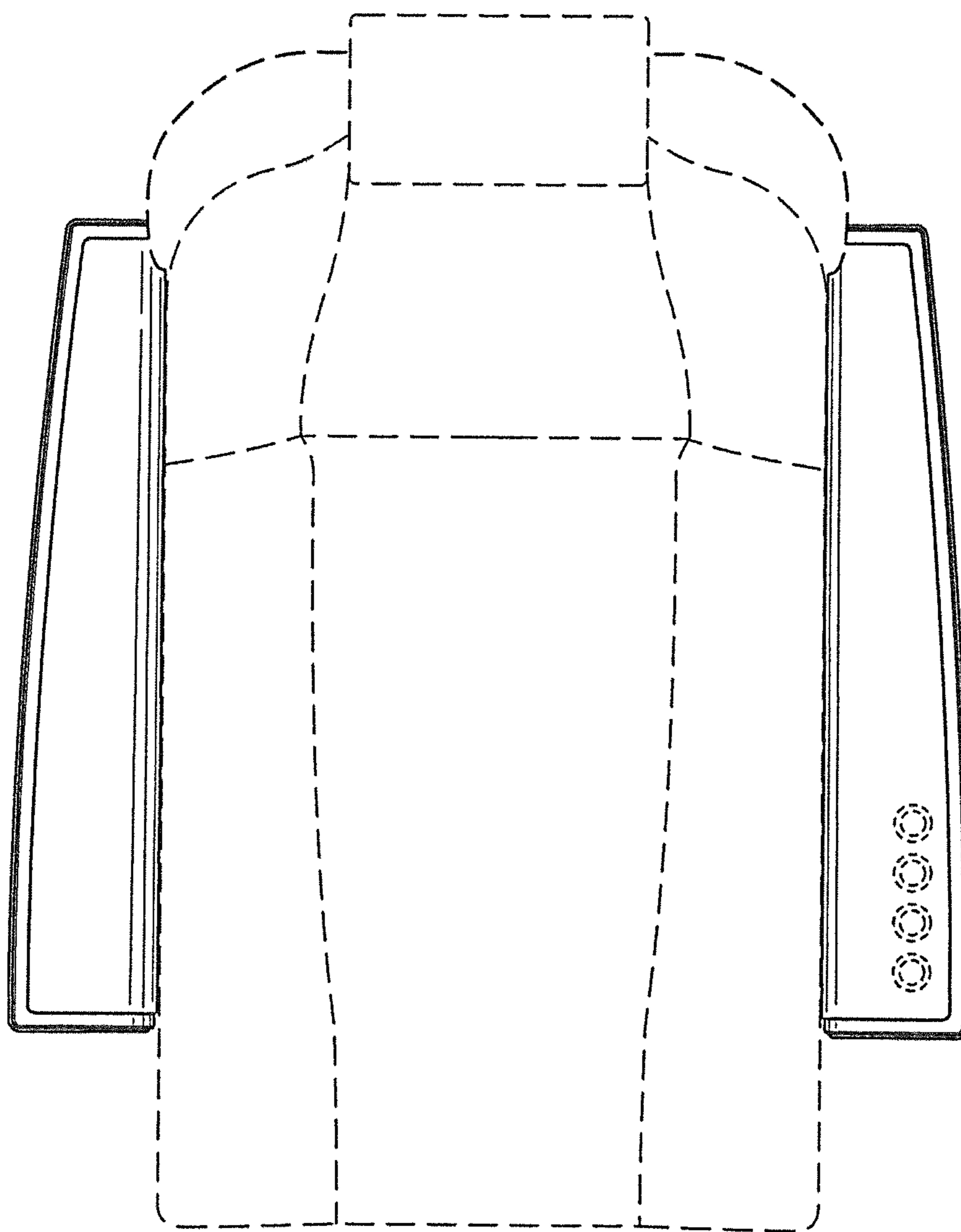

Fig. 5

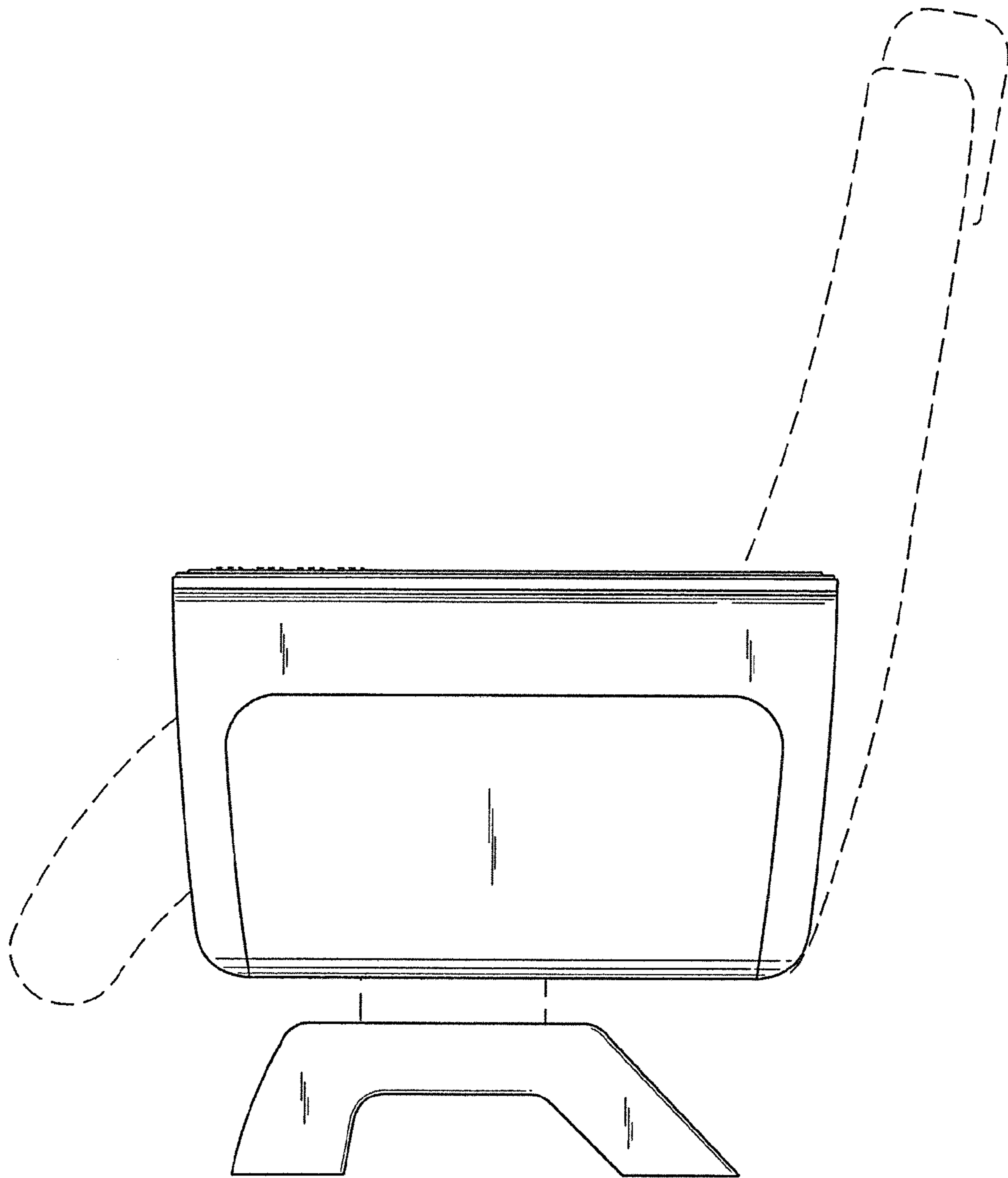

Fig. 6

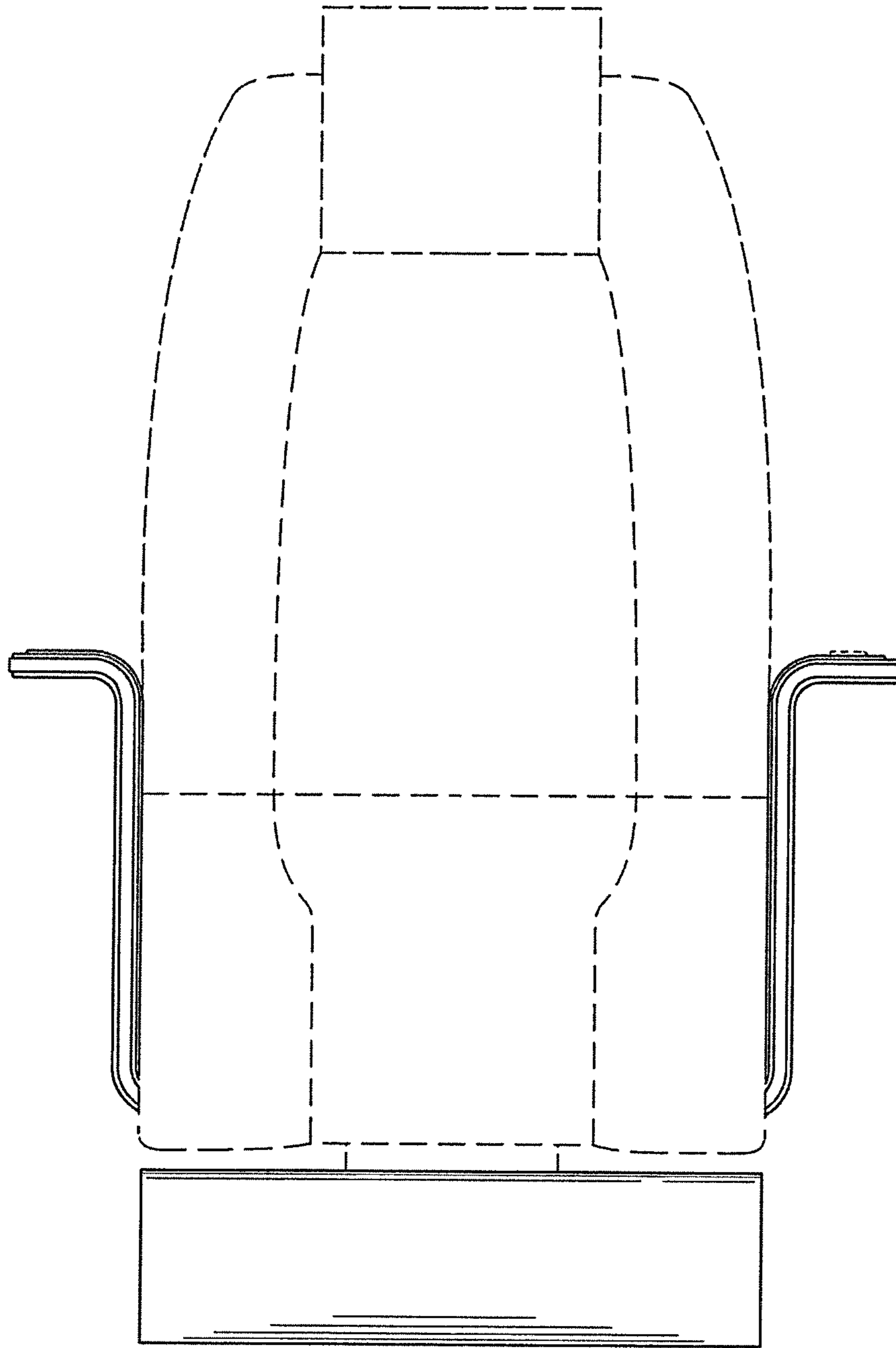

Fig. 7



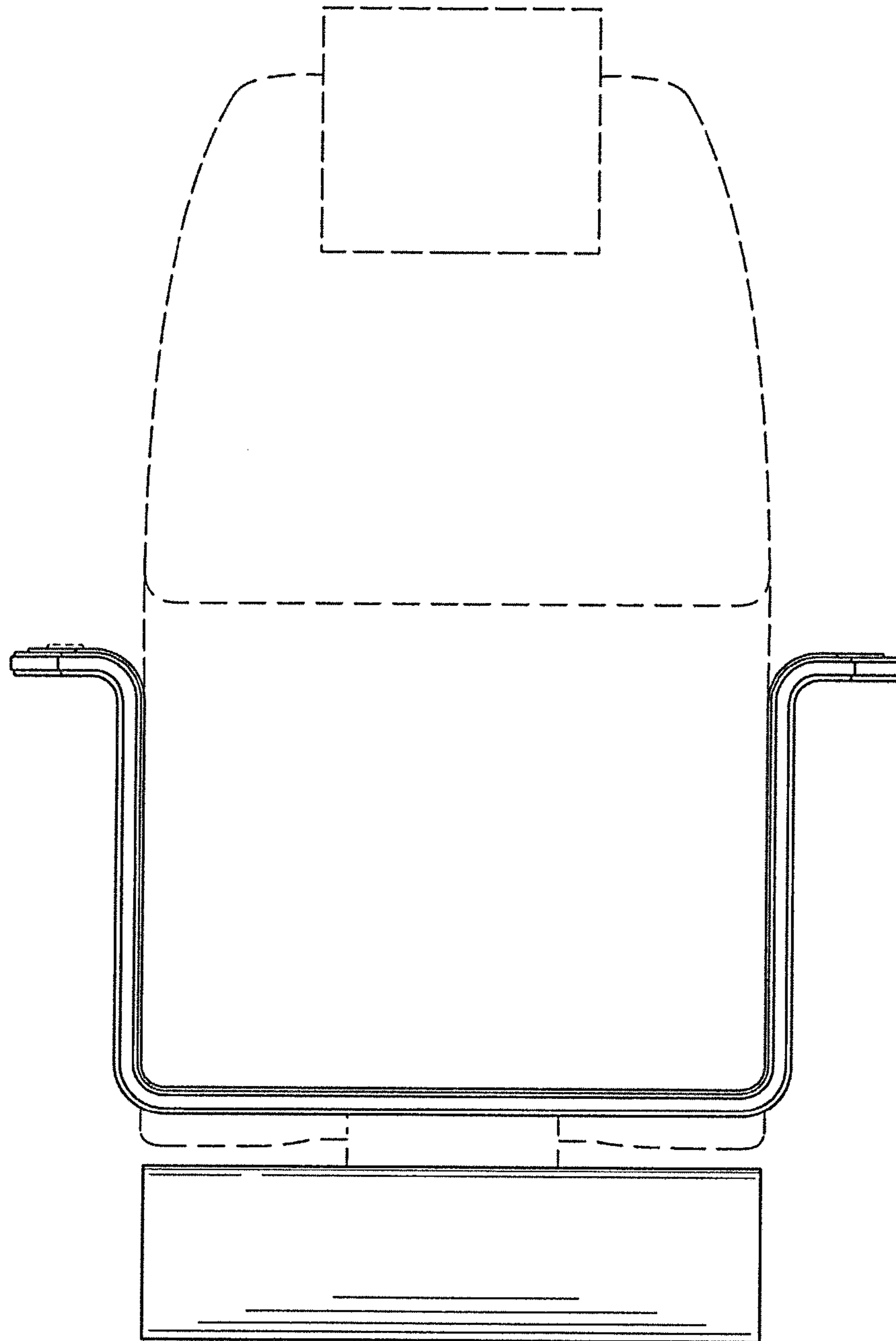

Fig. 8