

US00D730716S

(12) **United States Design Patent**
Weinerman et al.

(10) **Patent No.:** **US D730,716 S**
(45) **Date of Patent:** **** Jun. 2, 2015**

- (54) **HOUSING OF A LATCH ASSEMBLY**
- (71) Applicant: **The Eastern Company**, Cleveland, OH (US)
- (72) Inventors: **Lee S. Weinerman**, Medina, OH (US);
Fredrick L. Putzier, Columbia Station, OH (US)
- (73) Assignee: **The Eastern Company**, Strongsville, OH (US)
- (**) Term: **14 Years**
- (21) Appl. No.: **29/485,212**
- (22) Filed: **Mar. 17, 2014**

6,406,075	B1	6/2002	Rice et al.	
6,543,821	B1 *	4/2003	Weinerman et al.	292/123
D475,602	S *	6/2003	McCloskey	D8/331
D506,120	S	6/2005	Straka et al.	
D533,048	S	12/2006	Weinerman et al.	
D537,321	S	2/2007	Paige et al.	
D538,131	S	3/2007	Paige et al.	
D545,667	S	7/2007	Weinerman et al.	
D546,165	S	7/2007	Paige et al.	
D548,561	S	8/2007	Paige et al.	
D567,061	S	4/2008	Paige et al.	
7,398,664	B1	7/2008	Weinerman et al.	
D578,373	S	10/2008	Paige et al.	
7,454,933	B1	11/2008	Paige et al.	
D585,468	S	1/2009	Burns	
D587,558	S *	3/2009	Sarnowski	D8/331
D590,234	S *	4/2009	Wu et al.	D8/331

(Continued)

OTHER PUBLICATIONS

Eberhard Manufacturing Company, division of The Eastern Company, "Catalog 116", 2011, p. 39.

Primary Examiner — Prabhakar Deshmukh

(74) *Attorney, Agent, or Firm* — Walker & Jocke

CLAIM

The ornamental design for a housing of a latch assembly, as shown and described.

DESCRIPTION

FIG. 1 is a top, front, right side perspective view showing our new design for a housing of a latch assembly.

FIG. 2 is a front view thereof.

FIG. 3 is a right side view thereof, the left side thereof being a mirror image.

FIG. 4 is a top view thereof.

FIG. 5 is a bottom view thereof; and,

FIG. 6 is a top, front perspective view thereof.

The broken lines indicate unclaimed portions and form no part of the claimed design.

1 Claim, 5 Drawing Sheets

Related U.S. Application Data

(62) Division of application No. 29/438,552, filed on Nov. 30, 2012, now Pat. No. Des. 704,526.

(51) **LOC (10) Cl.** **08-07**

(52) **U.S. Cl.**
USPC **D8/331; D8/343**

(58) **Field of Classification Search**
USPC D8/330, 331, 335, 339, 302, 343;
70/141, 208; 292/336.3, 169, 358, 359,
292/170, 175, 165, 224, 140-145, 240-242,
292/DIG. 14, DIG. 30, DIG. 31, DIG. 4
See application file for complete search history.

References Cited

U.S. PATENT DOCUMENTS

4,706,478	A	11/1987	Swan et al.	
D324,636	S *	3/1992	Schlack et al.	D8/331
5,913,908	A *	6/1999	Czipri	70/208
5,984,383	A *	11/1999	Parikh et al.	292/121
D427,882	S	7/2000	Wytcherley et al.	
D429,141	S *	8/2000	Antonucci et al.	D8/331
6,109,669	A	8/2000	Pinkow	

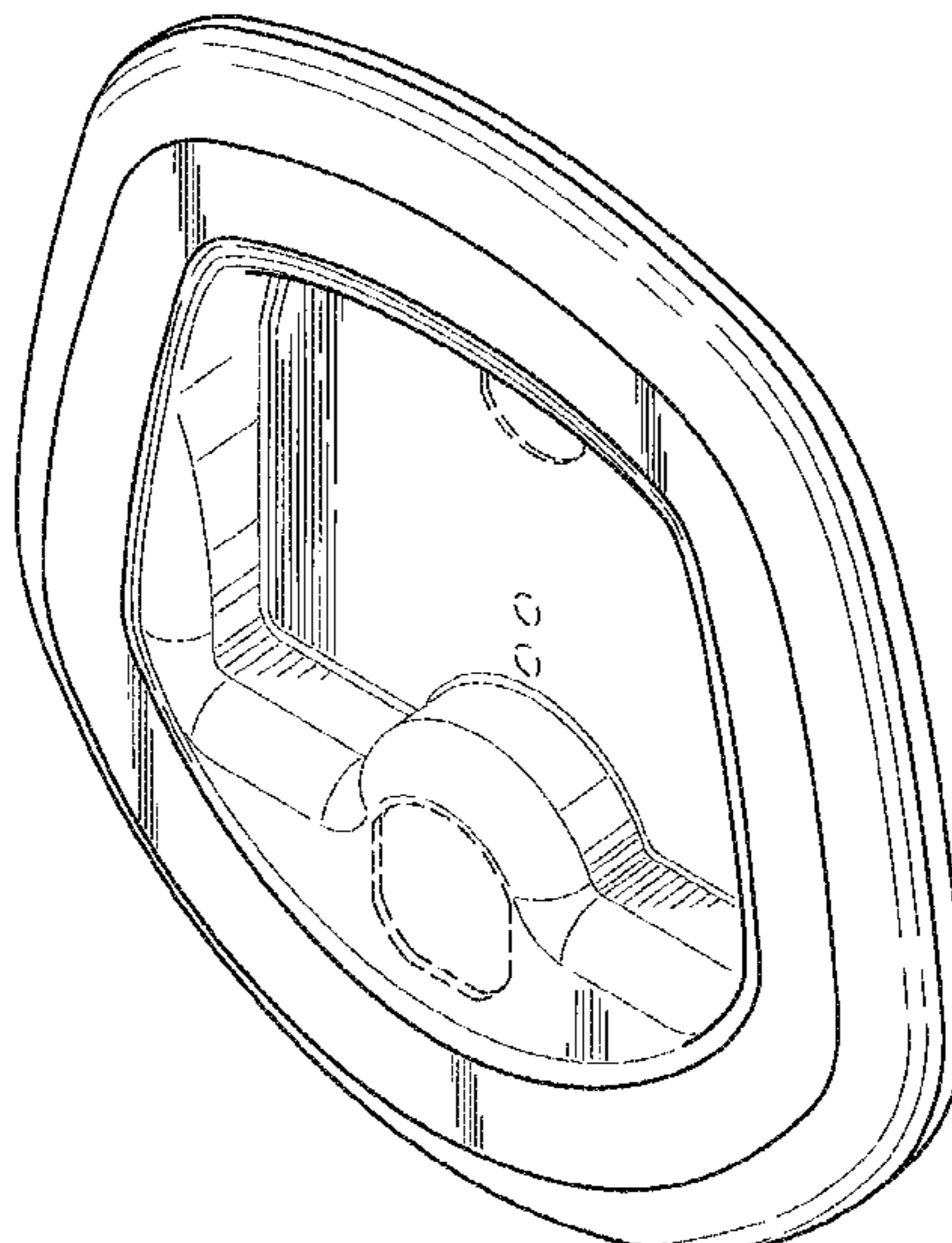

US D730,716 S

Page 2

(56)

References Cited

U.S. PATENT DOCUMENTS

D590,694 S 4/2009 Stuckey
D596,920 S 7/2009 Cotton et al.
7,748,246 B1 7/2010 Paige et al.

D624,800 S 10/2010 Burns
D624,803 S 10/2010 Frankham et al.
D644,911 S 9/2011 Le
D678,750 S 3/2013 Tung

* cited by examiner

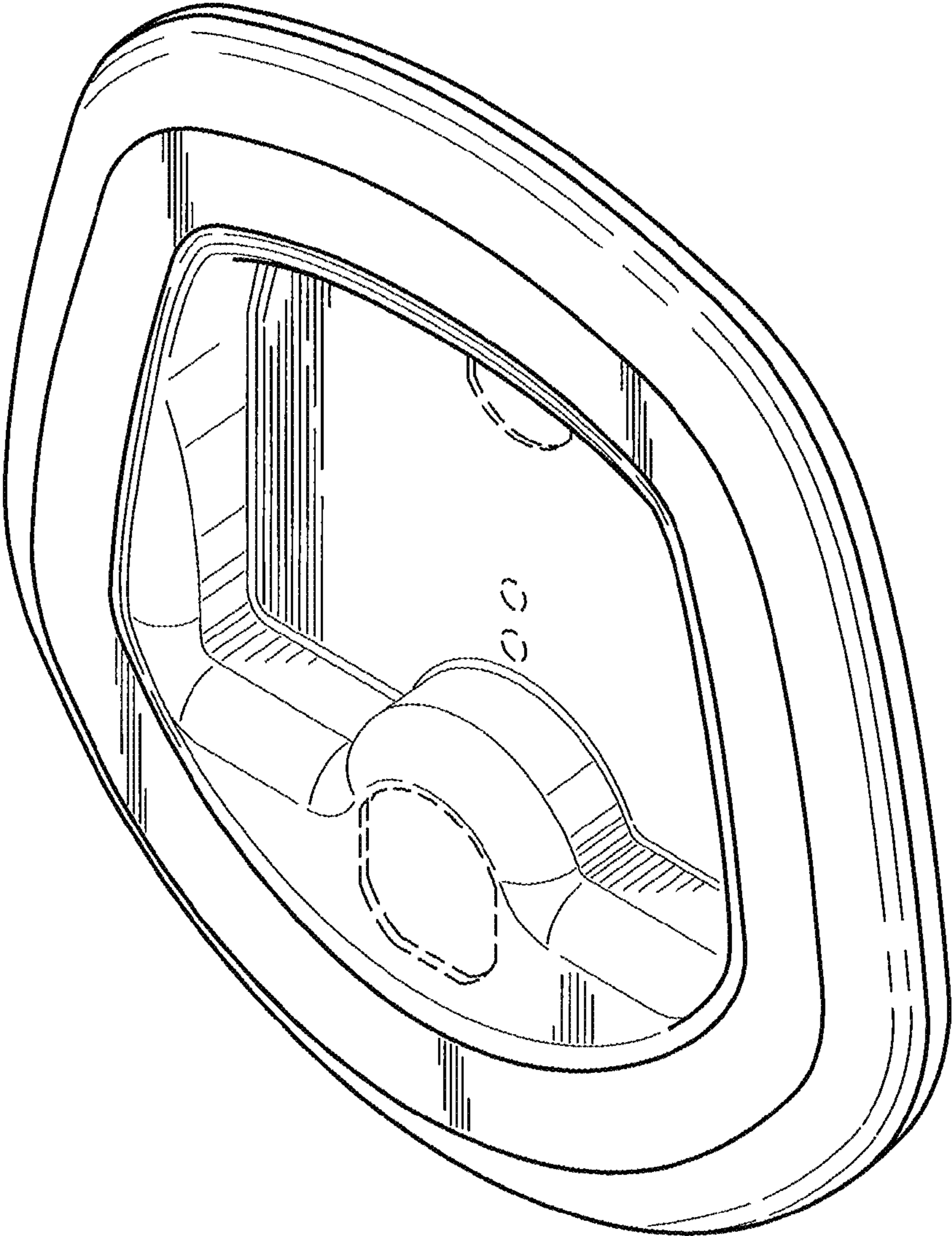

FIG. 1

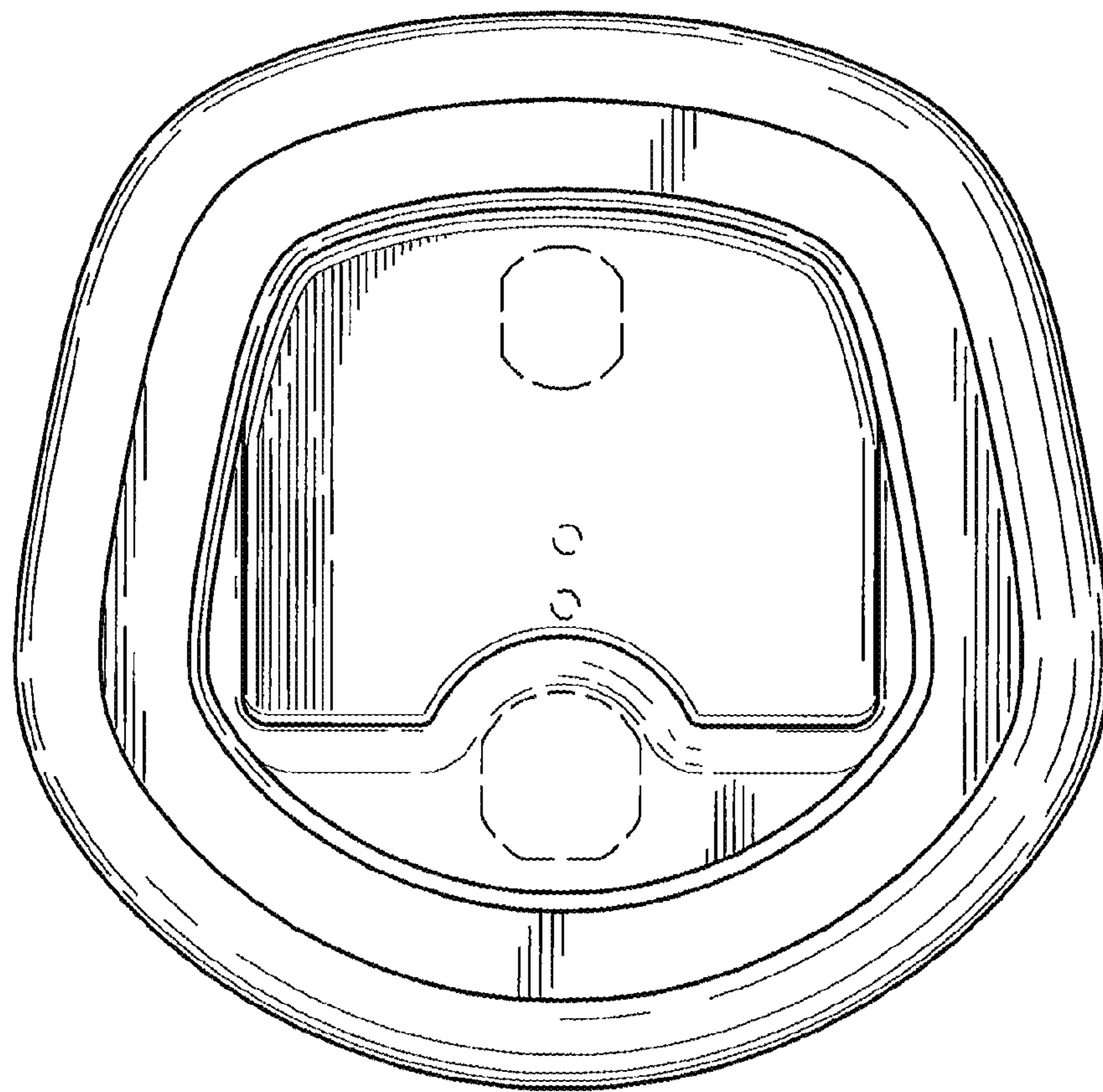

FIG. 2



FIG. 3



FIG. 4

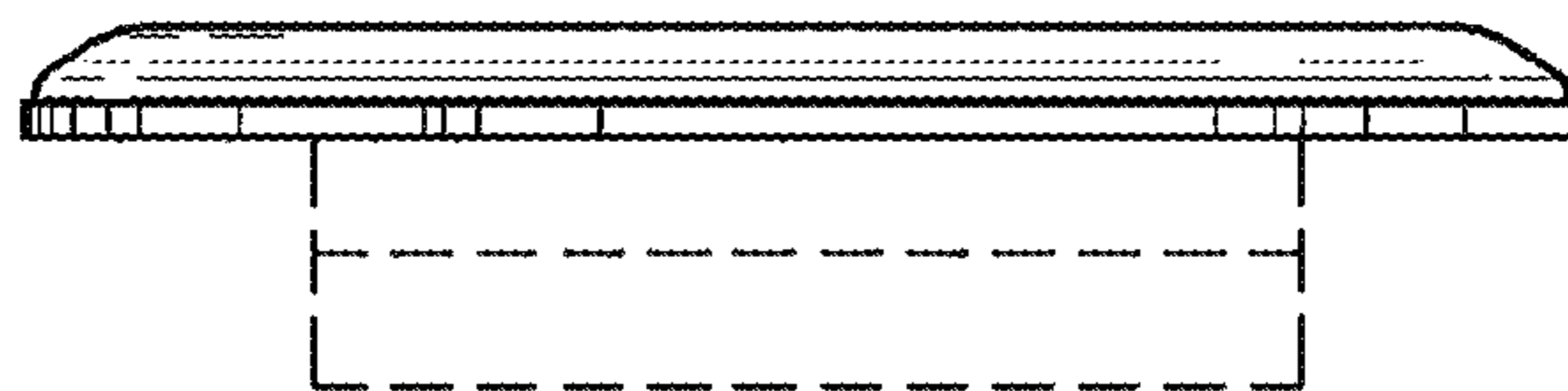

FIG. 5

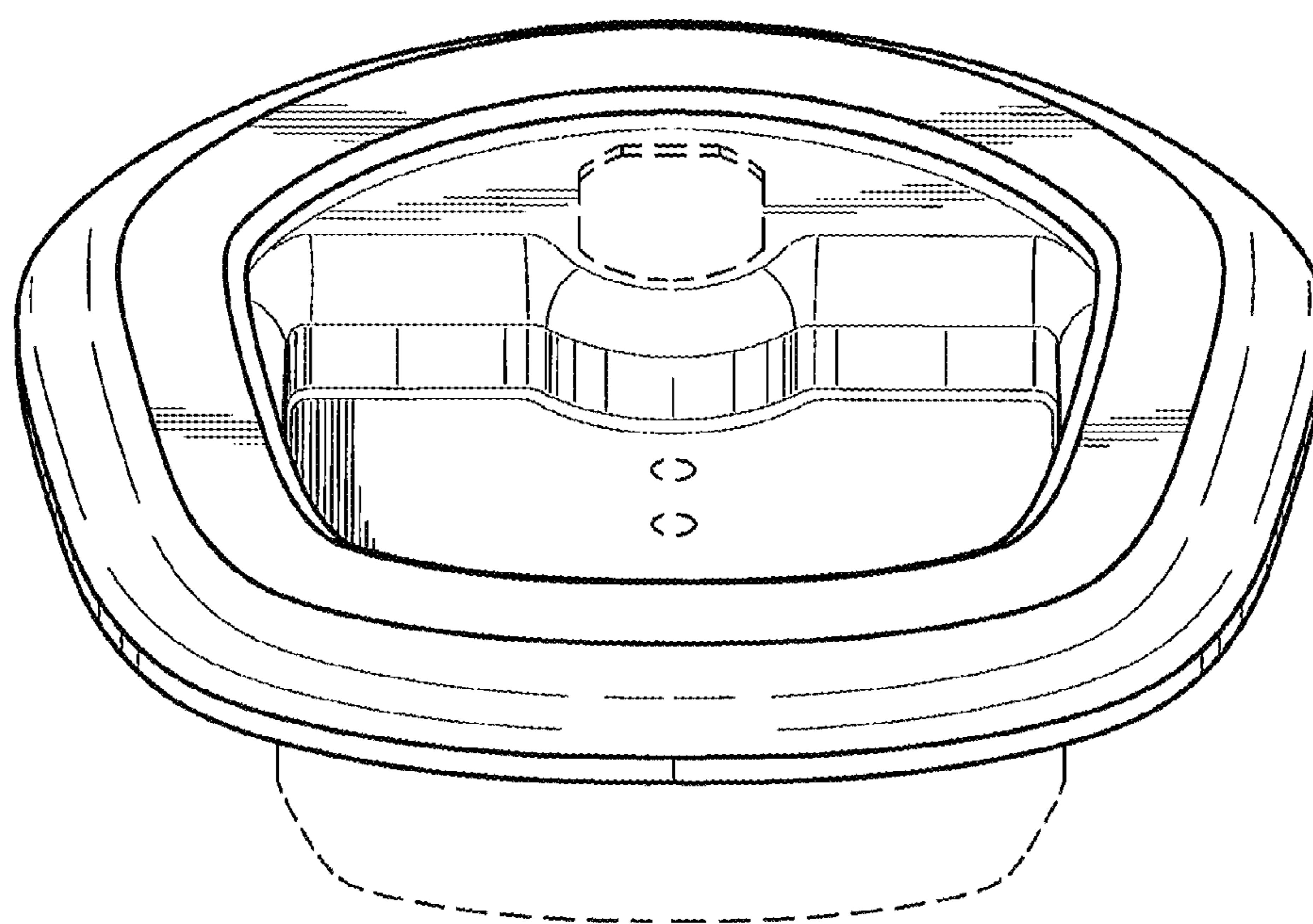

FIG. 6