

US00D730419S

(12) **United States Design Patent**  
**Pungetti et al.**

(10) **Patent No.:** **US D730,419 S**  
(45) **Date of Patent:** **\*\* May 26, 2015**

(54) **PAINT SPRAY BOOTH**  
(71) Applicant: **CEFLA SOCIETA' COOPERATIVA,**  
Imola (IT)  
(72) Inventors: **Cristian Pungetti,** Ozzano Dell'Emilia  
(IT); **Stefano Chiarini,** Conselice (IT)  
(73) Assignee: **CEFLA SOCIETA' COOPERATIVA,**  
Province of Bologna (IT)

(\*\*) Term: **14 Years**

(21) Appl. No.: **29/452,665**

(22) Filed: **Apr. 19, 2013**

(30) **Foreign Application Priority Data**

Oct. 31, 2012 (EM) ..... 002128090-0001

(51) **LOC (10) Cl.** ..... **15-99**

(52) **U.S. Cl.**  
USPC ..... **D15/199**

(58) **Field of Classification Search**  
USPC ..... D15/122, 135, 199  
See application file for complete search history.

(56) **References Cited**

**U.S. PATENT DOCUMENTS**

D274,088 S \* 5/1984 Nilsson et al. .... D15/199  
D287,749 S \* 1/1987 Nilsson et al. .... D23/314  
5,690,995 A \* 11/1997 Fischli et al. .... 427/180  
5,922,130 A \* 7/1999 Mosser et al. .... 118/326  
6,027,566 A \* 2/2000 Telchuk et al. .... 118/326  
D567,264 S \* 4/2008 Muller et al. .... D15/122

D655,323 S \* 3/2012 Brockhage ..... D15/145  
D674,420 S \* 1/2013 Ueberschlag et al. .... D15/122  
D685,825 S \* 7/2013 Hoelbl ..... D15/122  
2005/0170768 A1 \* 8/2005 Kelly ..... 454/53  
2006/0233960 A1 \* 10/2006 Warren et al. .... 427/421.1  
2007/0062444 A1 \* 3/2007 Shutic et al. .... 118/309  
2007/0166463 A1 \* 7/2007 Kelly ..... 427/345  
2008/0003349 A1 \* 1/2008 Van Sciver et al. .... 427/8  
2010/0272915 A1 \* 10/2010 Laws ..... 427/421.1  
2010/0293909 A1 \* 11/2010 Thomason ..... 55/385.1  
2013/0042805 A1 \* 2/2013 Shutic ..... 118/308  
2014/0030439 A1 \* 1/2014 Schmidt ..... 427/427.2  
2014/0099448 A1 \* 4/2014 Milli ..... 427/475

\* cited by examiner

*Primary Examiner* — Patricia Palasik

(74) *Attorney, Agent, or Firm* — Marvin Petry; Stites & Harbison PLLC

(57) **CLAIM**

The ornamental design for a paint spray booth, as shown and described.

**DESCRIPTION**

FIG. 1 is a perspective view from the front and left of a paint spray booth showing my new design.  
FIG. 2 is a perspective view from the front and right thereof.  
FIG. 3 is a front elevational view thereof.  
FIG. 4 is a rear elevational view thereof.  
FIG. 5 is a top plan view thereof.  
FIG. 6 is a left side elevational view thereof; and,  
FIG. 7 is a right side elevational view thereof.  
The broken lines in the drawings depict unclaimed environmental subject matter.

**1 Claim, 7 Drawing Sheets**

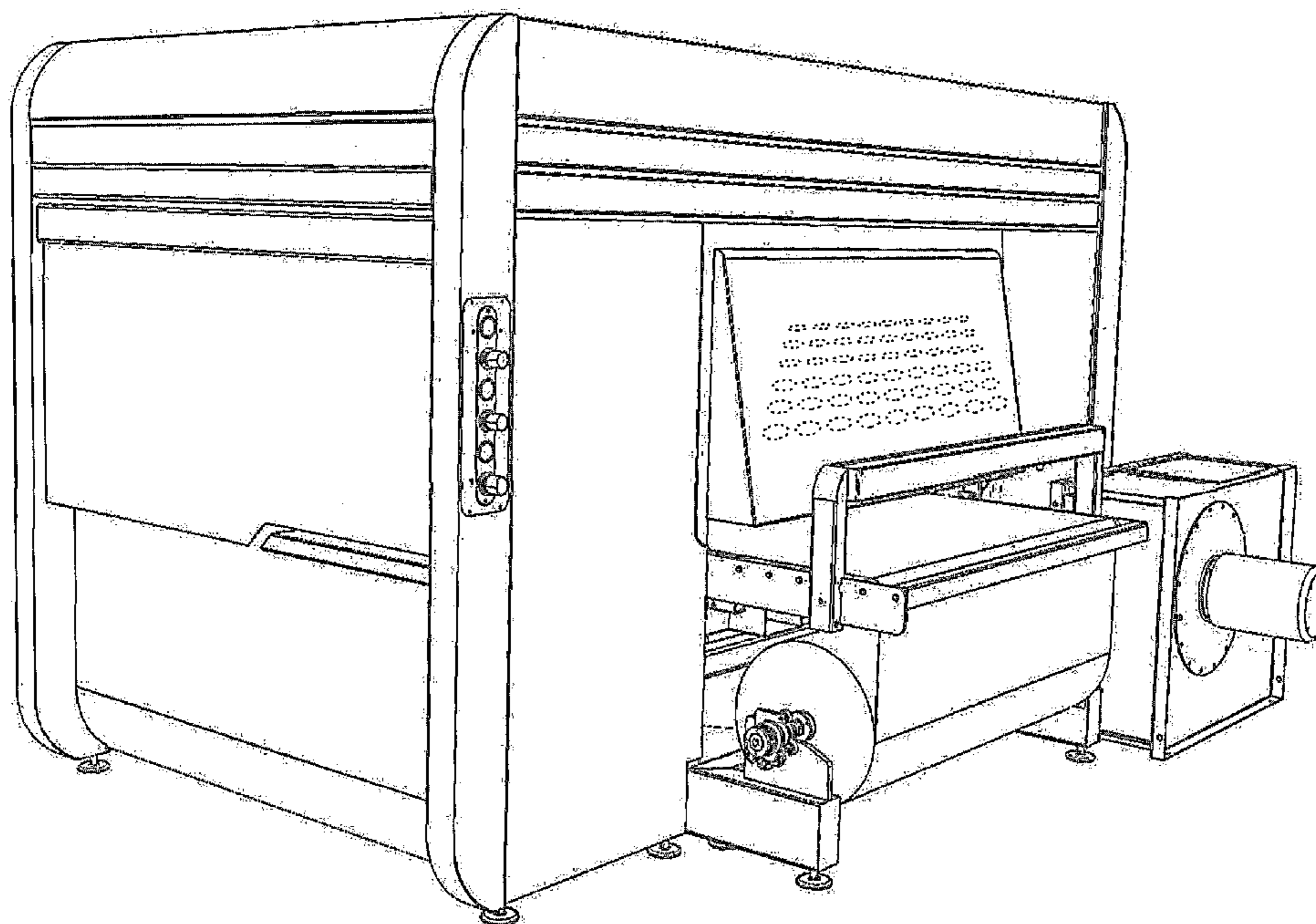

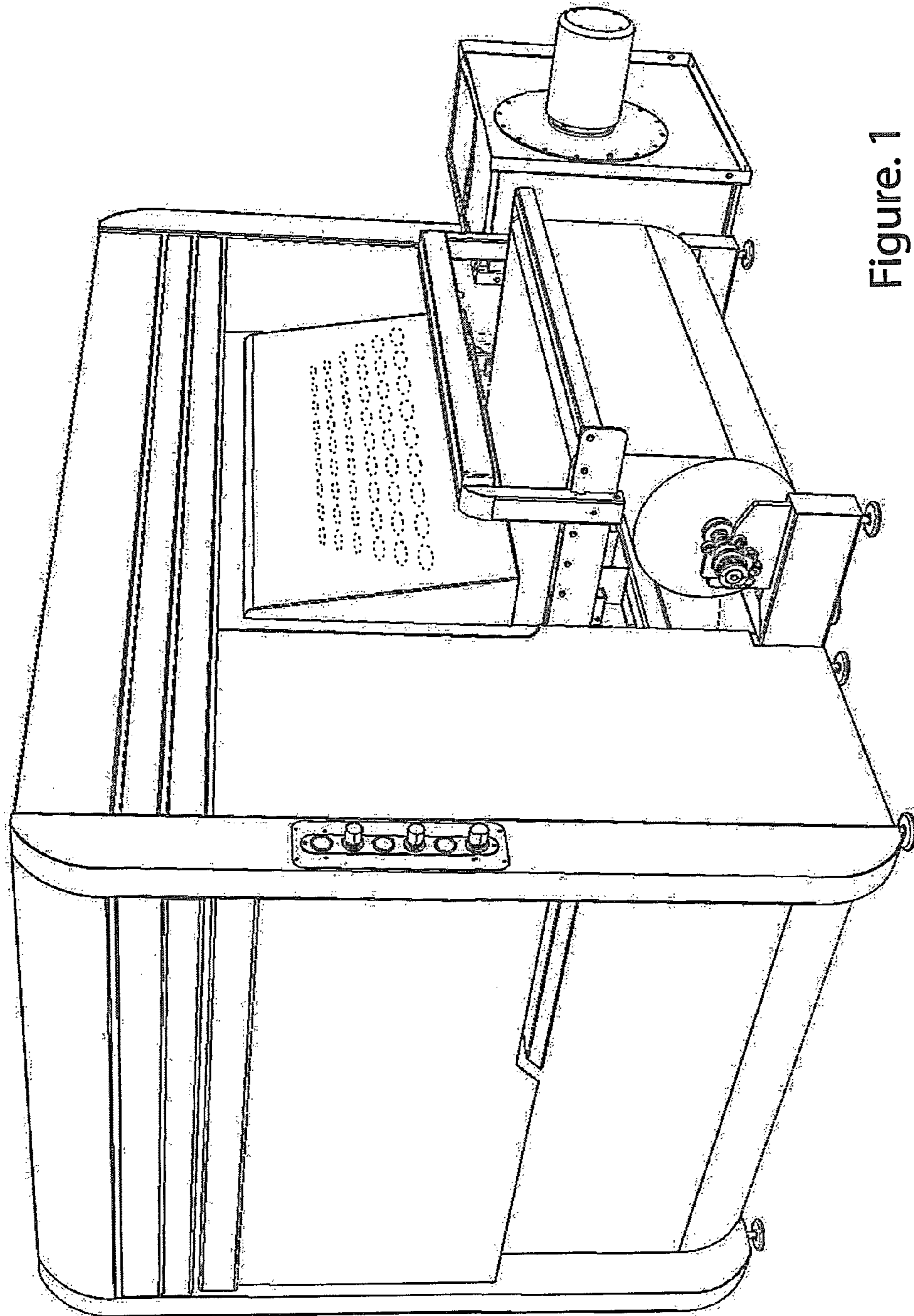

Figure. 1

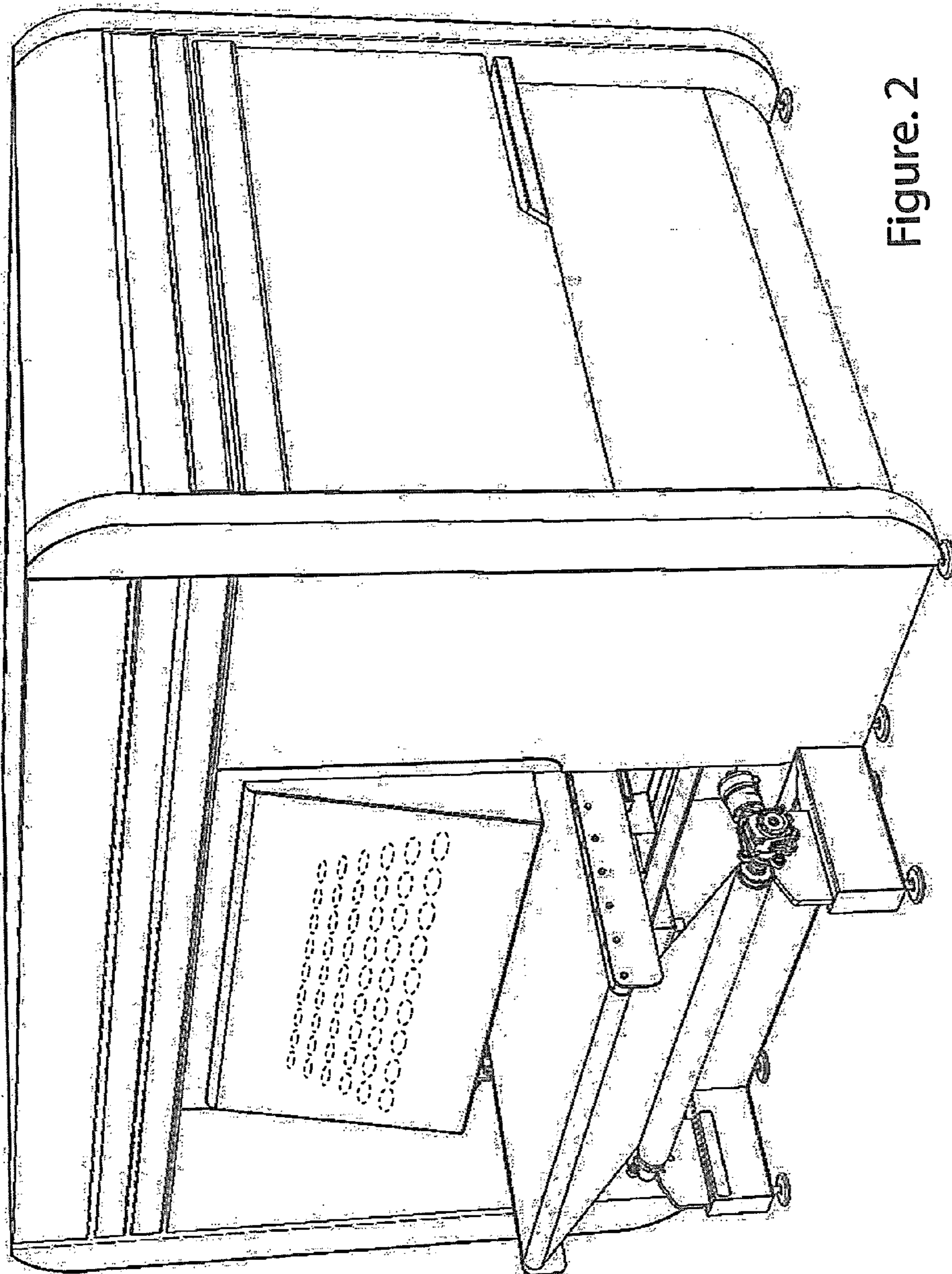

Figure. 2

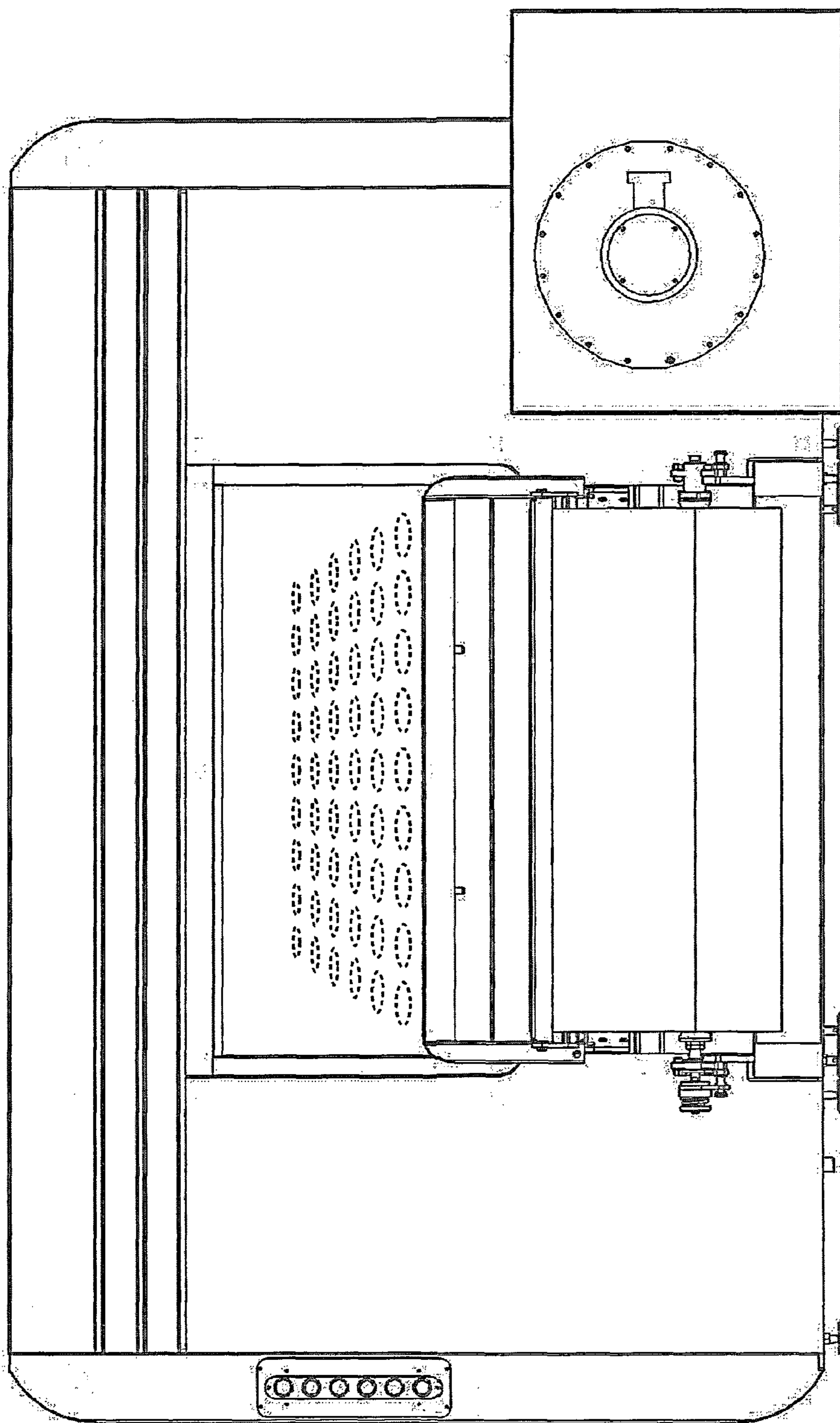

Figure. 3

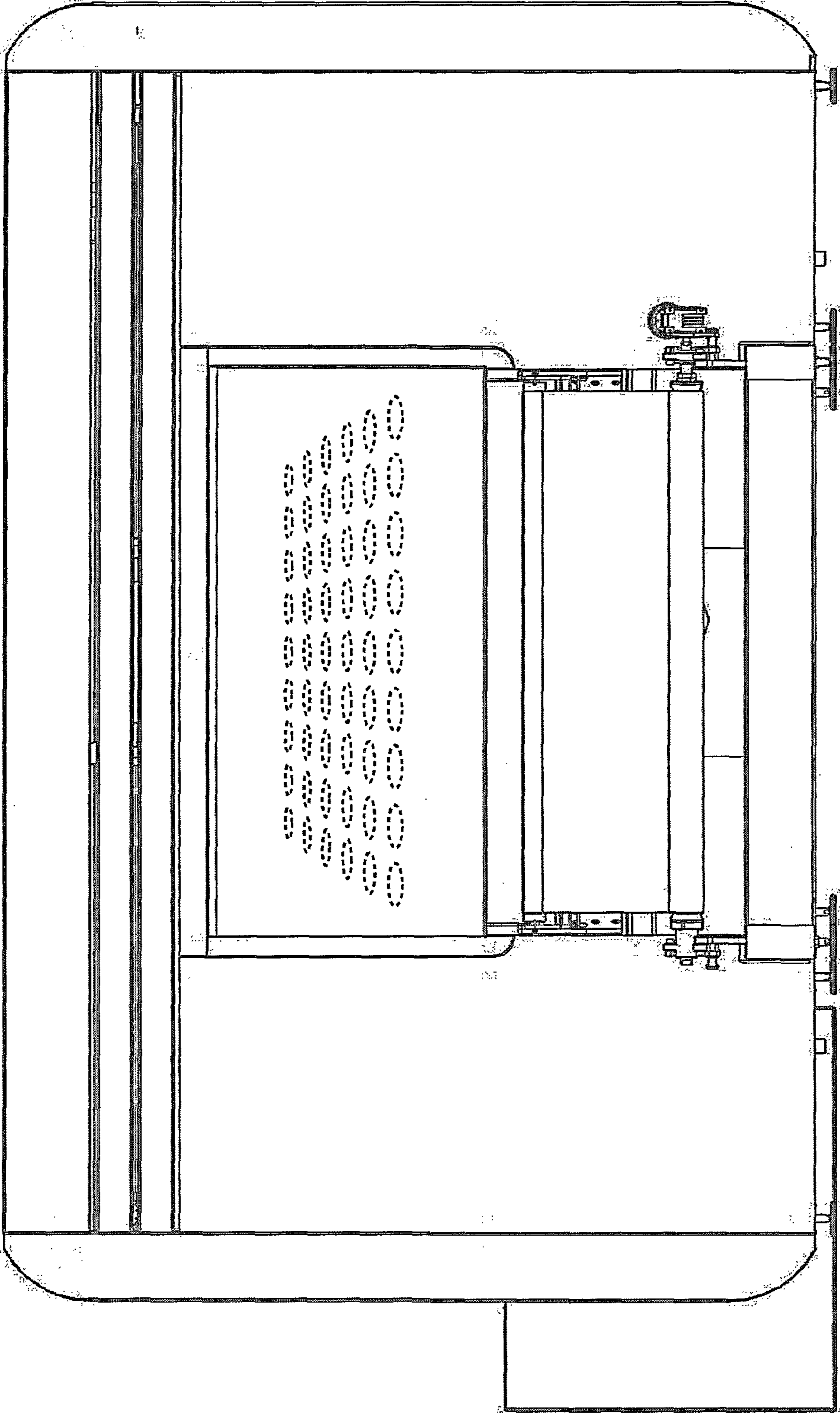

Figure. 4

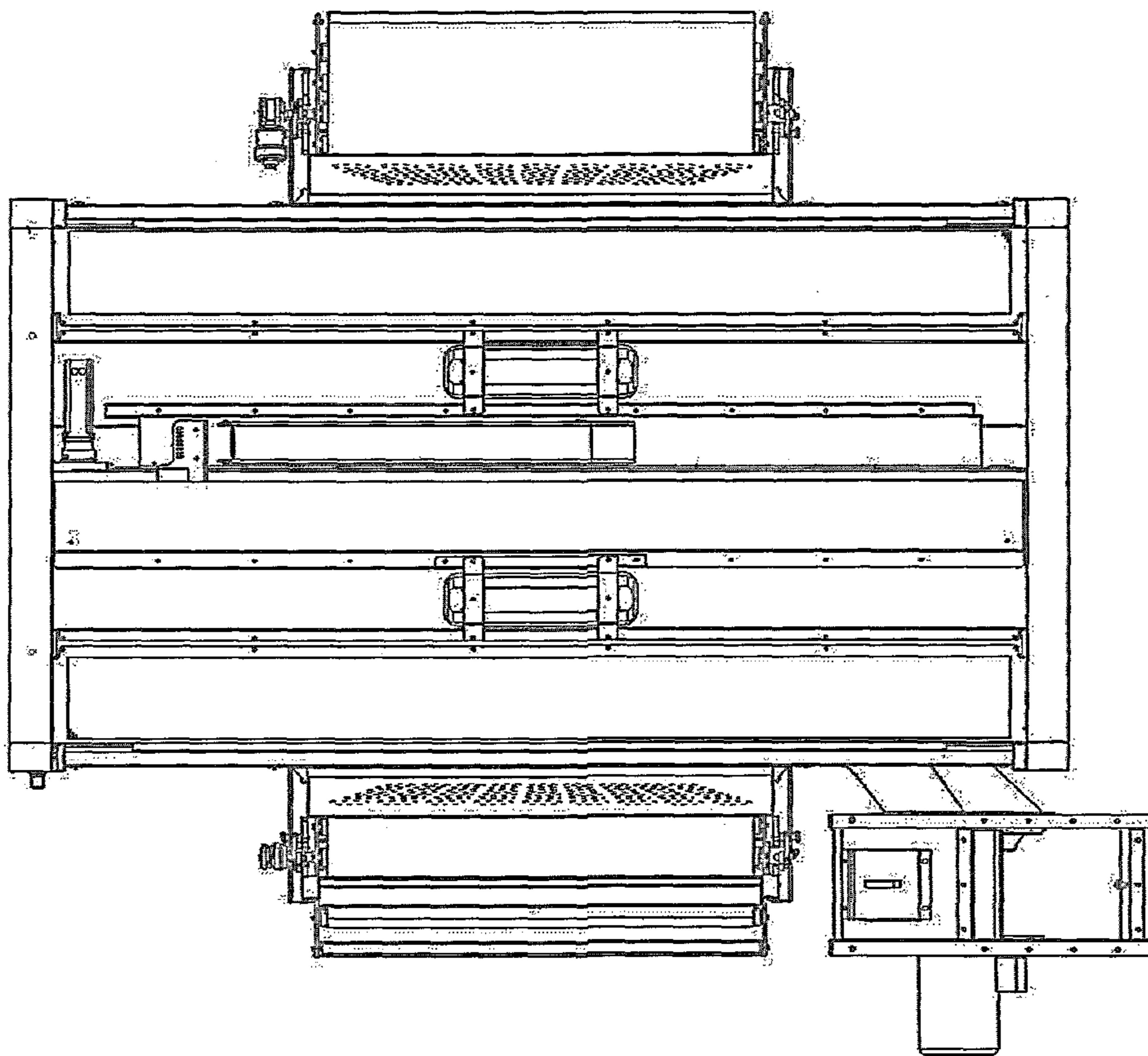

Figure. 5

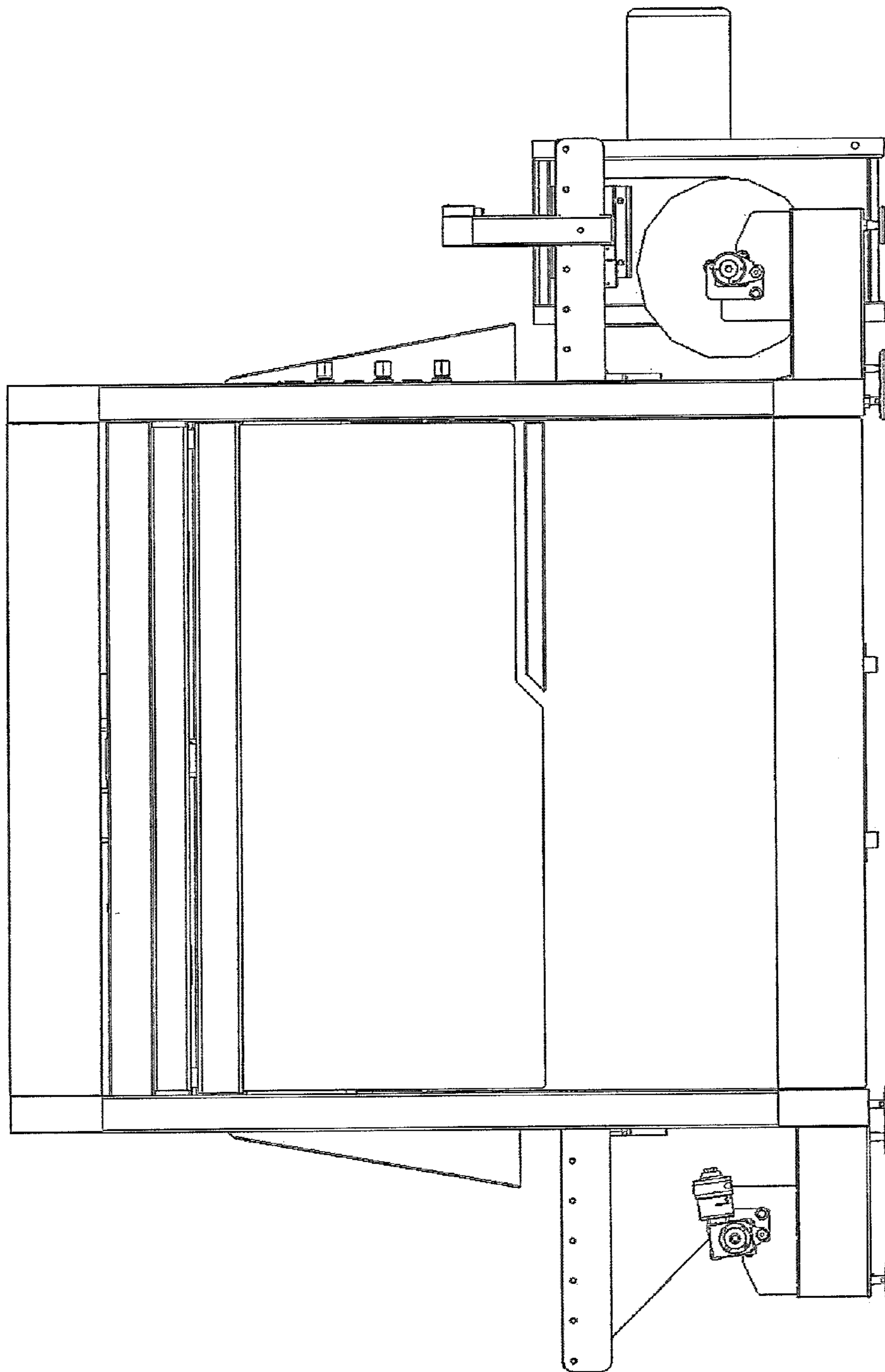

Figure 6

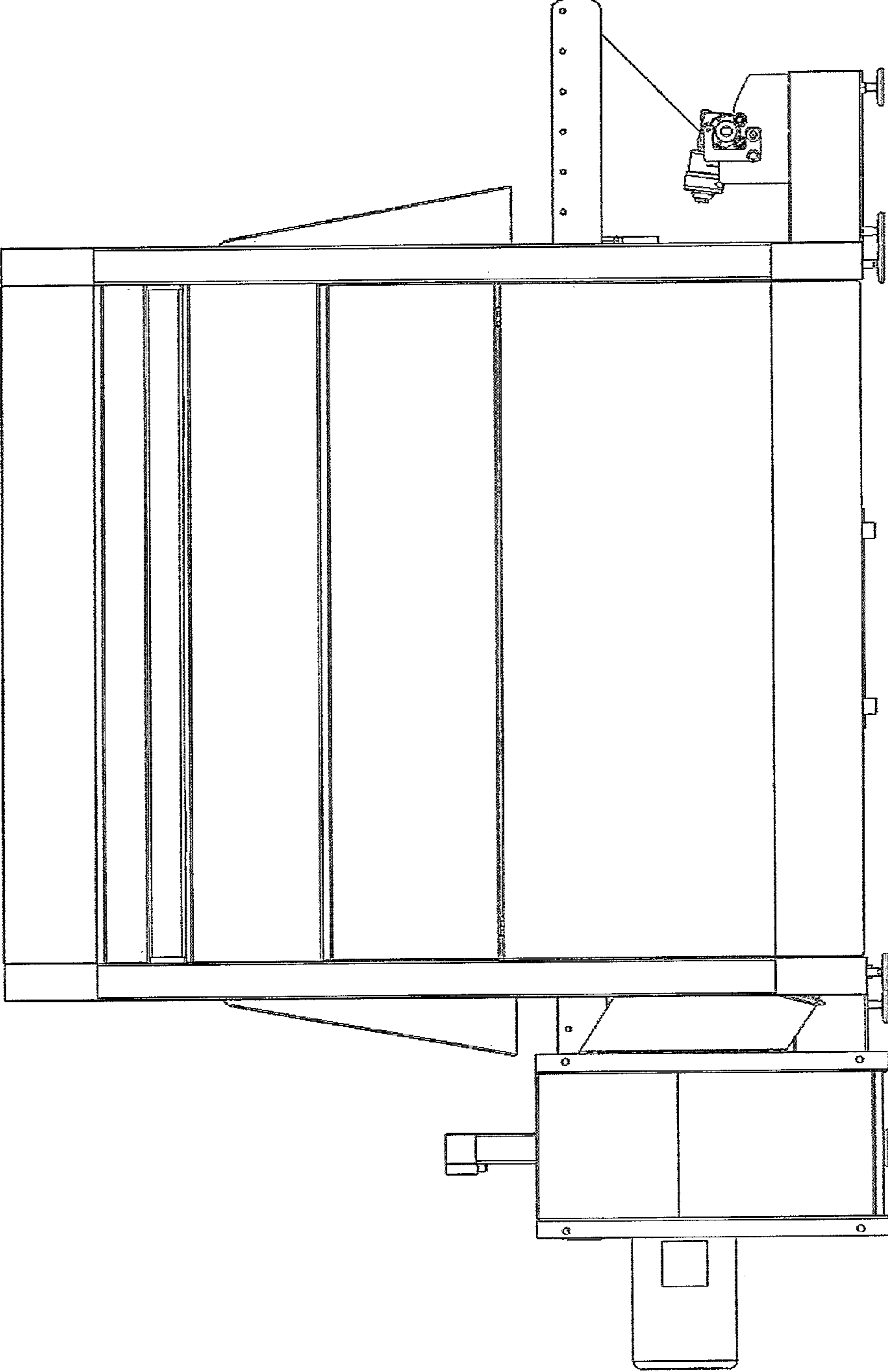

Figure 7