



US00D730244S

(12) **United States Design Patent**  
**Earon**

(10) **Patent No.:** **US D730,244 S**

(45) **Date of Patent:** **\*\* May 26, 2015**

(54) **UNMANNED AERIAL VEHICLE**

(56) **References Cited**

(71) Applicant: **WINEHAWK INC.**, Thornhill (CA)

U.S. PATENT DOCUMENTS

(72) Inventor: **Ernest Earon**, Thornhill (CA)

743,301	A *	11/1903	Lischtiak	244/153 R
1,507,192	A *	9/1924	Laukandt	446/60
2,762,590	A *	9/1956	Huie	244/153 R
3,787,998	A	1/1974	Kilroy et al.	
3,839,818	A	10/1974	Heggedal	
4,863,413	A	9/1989	Schwarz	
4,911,384	A	3/1990	Stankus	
5,150,860	A	9/1992	Young	
5,524,851	A	6/1996	Huang	
5,609,312	A	3/1997	Arlton et al.	
5,836,545	A	11/1998	Arlton et al.	
6,095,458	A	8/2000	Cripe	
6,142,419	A	11/2000	Arlton	
6,520,823	B2	2/2003	Tian et al.	
6,742,741	B1	6/2004	Rivoli	
6,868,314	B1	3/2005	Bentley	
7,059,566	B2	6/2006	Byers et al.	
7,073,748	B2	7/2006	Maurer et al.	
7,168,657	B2	1/2007	Chen	

(73) Assignee: **PRECISIONHAWK INC.**, Thornhill (CA)

(\*\*) Term: **14 Years**

(21) Appl. No.: **29/487,762**

(22) Filed: **Apr. 11, 2014**

**Related U.S. Application Data**

(62) Division of application No. 29/454,606, filed on May 13, 2013, now Pat. No. Des. 706,678.

(51) **LOC (10) Cl.** ..... **12-07**

(52) **U.S. Cl.**  
USPC ..... **D12/16.1**; D12/319; D12/344; D21/450

(58) **Field of Classification Search**  
CPC ..... B64C 1/00; B64C 3/10; B64C 11/16;  
B64C 2201/00; B64C 2201/021; B64C  
2201/12; B64C 2201/123; B64C 2201/146;  
B64C 2203/00; A63H 27/00; A63H 27/02  
USPC ..... D12/16.1, 319, 320, 321, 323, 326, 327,  
D12/333, 337, 339, 344, 345; D21/430,  
D21/436, 437, 438, 442, 445, 446, 447, 449,  
D21/450, 453; 244/2, 4 R, 5, 6, 12.1-12.4,  
244/13, 17.11, 100 R, 108, 60, 153 R, 117 R,  
244/119; 446/35, 36, 57, 60, 61, 62, 63,  
446/230, 232; 701/3; 703/3

See application file for complete search history.

(Continued)

*Primary Examiner* — Martie K Holtje  
(74) *Attorney, Agent, or Firm* — Gowling Lafleur  
Henderson LLP; Joseph Conneely

(57) **CLAIM**  
The ornamental design for an unmanned aerial vehicle, as shown and described.

**DESCRIPTION**

FIG. 1 is a front perspective view of an unmanned aerial vehicle according to the design;  
FIG. 2 is a front view thereof;  
FIG. 3 is a rear view thereof;  
FIG. 4 is a right side view thereof drawn to an enlarged scale;  
FIG. 5 is a left side view thereof drawn to an enlarged scale;  
FIG. 6 is a top view of FIG. 1; and,  
FIG. 7 is a bottom view of FIG. 1.  
The portions shown in broken lines in FIGS. 3 and 7 do not form part of the claimed design.

**1 Claim, 7 Drawing Sheets**

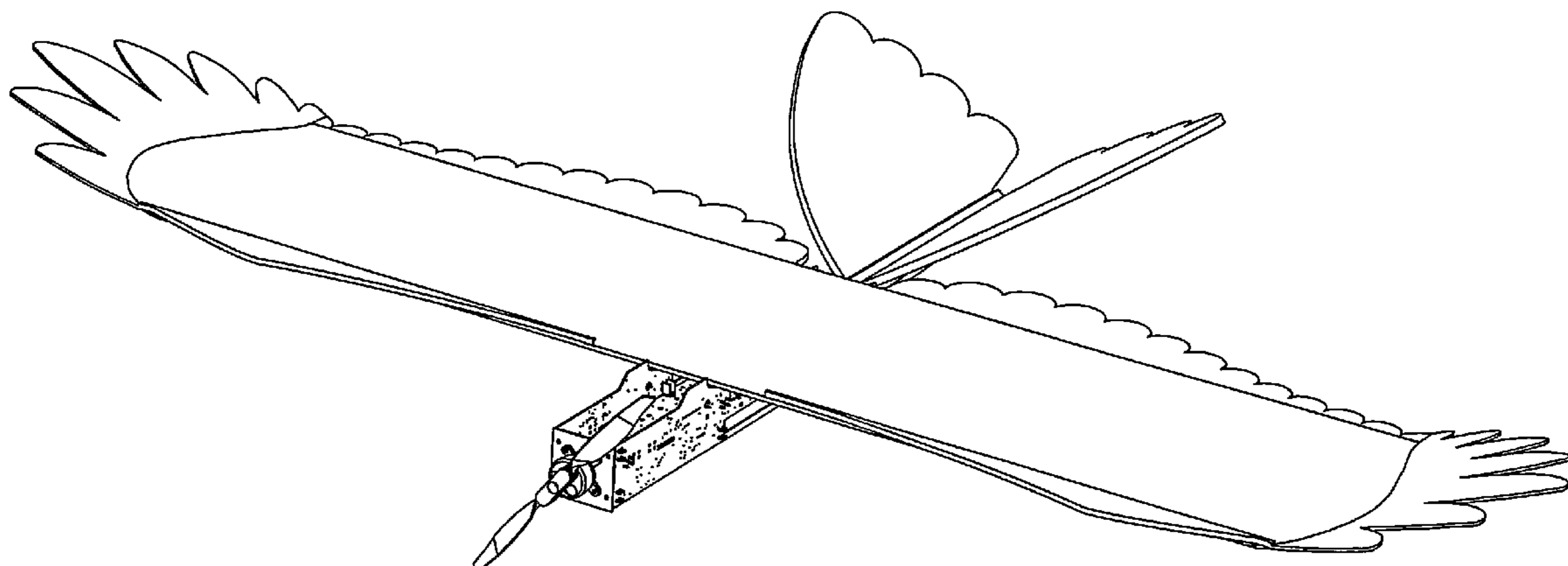

(56)

**References Cited**

U.S. PATENT DOCUMENTS

7,391,622	B2	6/2008	Marshall et al.						
D581,992	S *	12/2008	Wang .....	D21/449					
D585,370	S	1/2009	Tu						
D596,267	S	7/2009	Colgren et al.						
D608,268	S	1/2010	Iori						
D621,774	S *	8/2010	Betsch .....	D12/344					
D629,737	S *	12/2010	Betsch .....	D12/319					
D656,999	S	4/2012	Frederick						
					8,201,773	B1	6/2012	Durham et al.	
					D665,331	S	8/2012	Sands	
					8,242,623	B2	8/2012	Lucero et al.	
					D706,678	S *	6/2014	Earon .....	D12/16.1
					2002/0173217	A1 *	11/2002	Kinkade .....	446/35
					2004/0007646	A1 *	1/2004	Chang .....	244/153 R
					2006/0255209	A1 *	11/2006	Chen .....	244/108
					2008/0125920	A1	5/2008	Miles et al.	
					2010/0120273	A1	5/2010	Lucero et al.	
					2010/0323579	A1	12/2010	Liang et al.	
					2013/0105628	A1 *	5/2013	Buscher et al. ....	244/119

\* cited by examiner

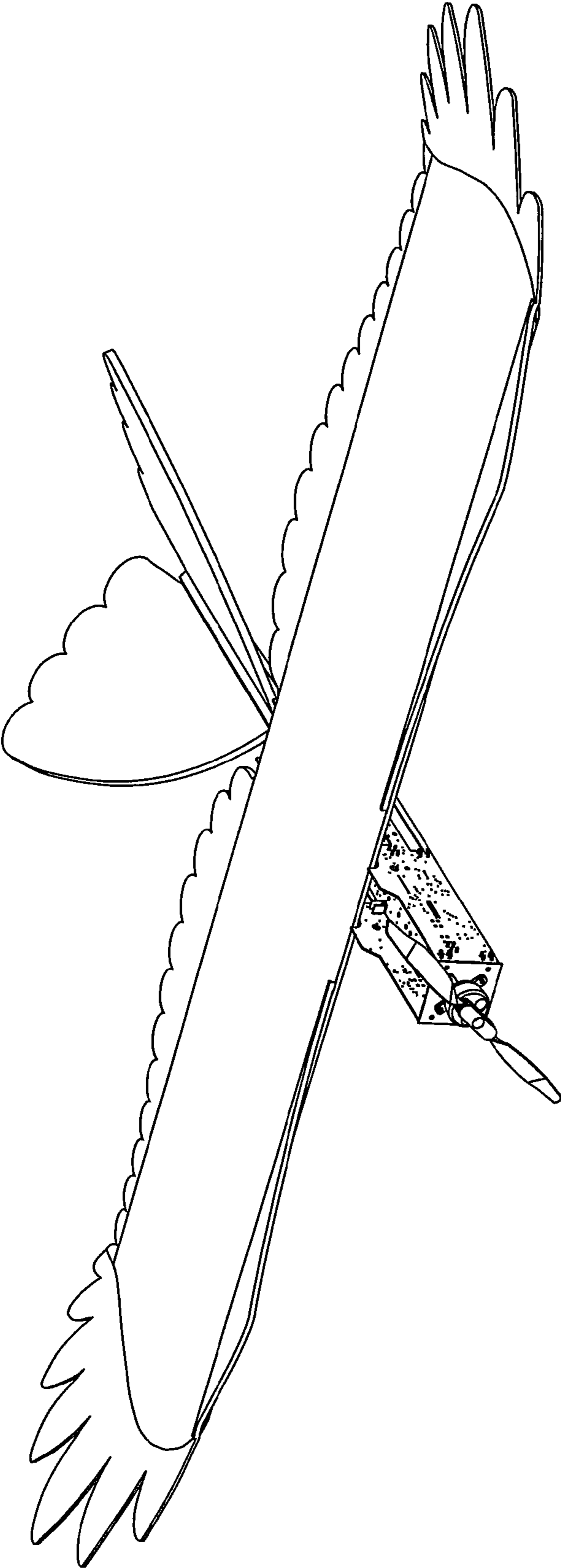

FIG. 1

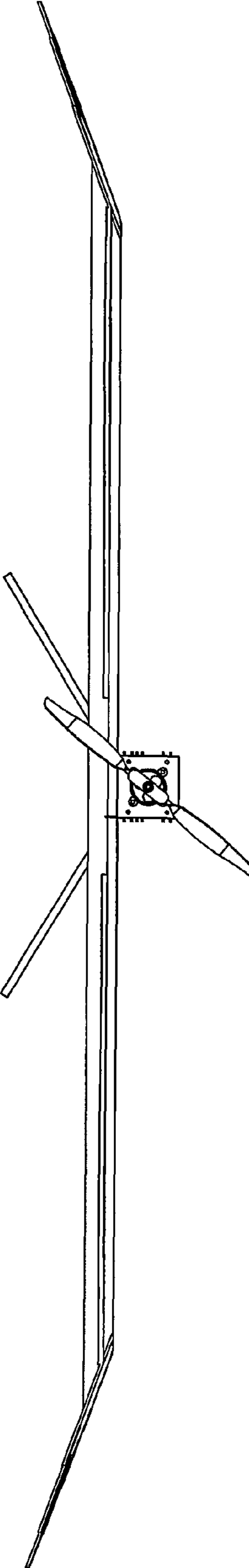

FIG. 2

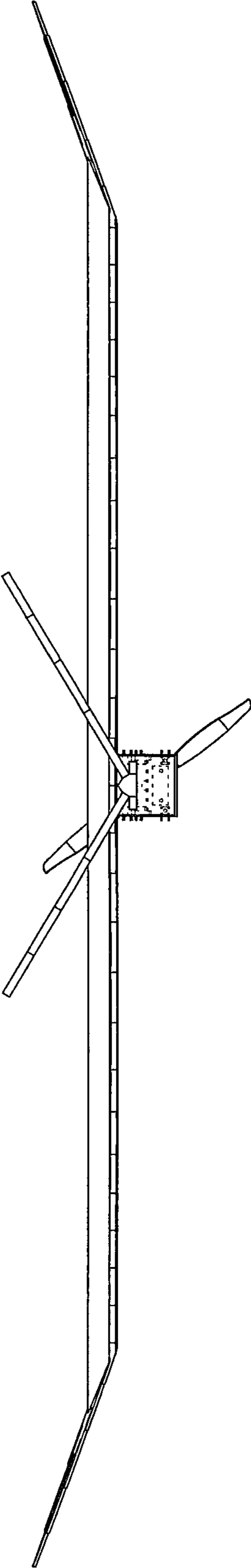

FIG.3

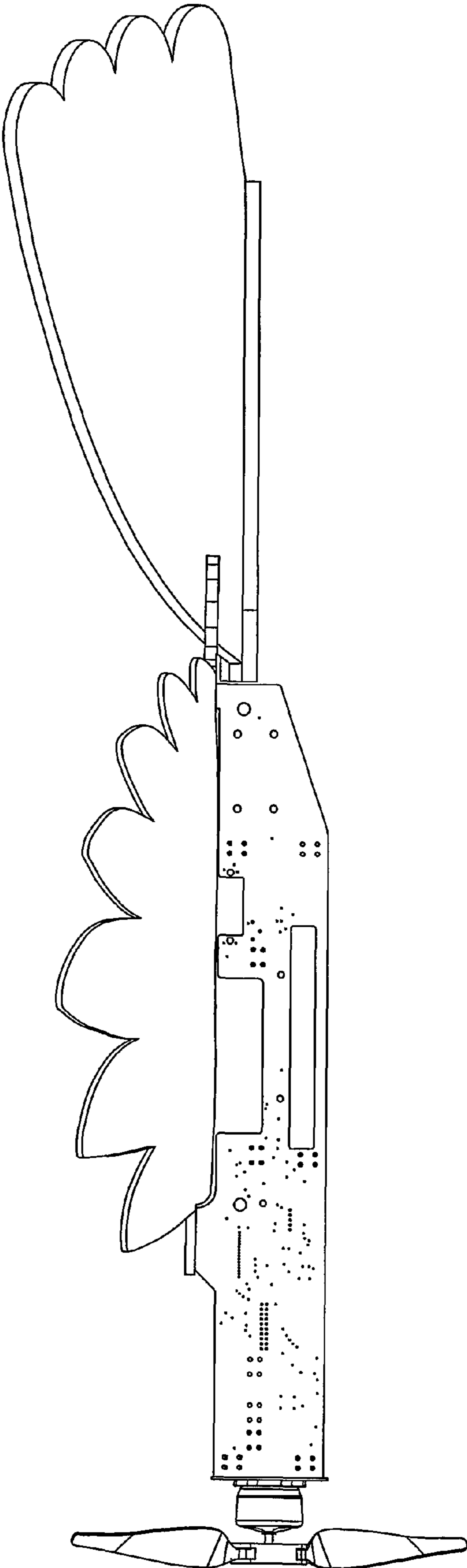

FIG. 4

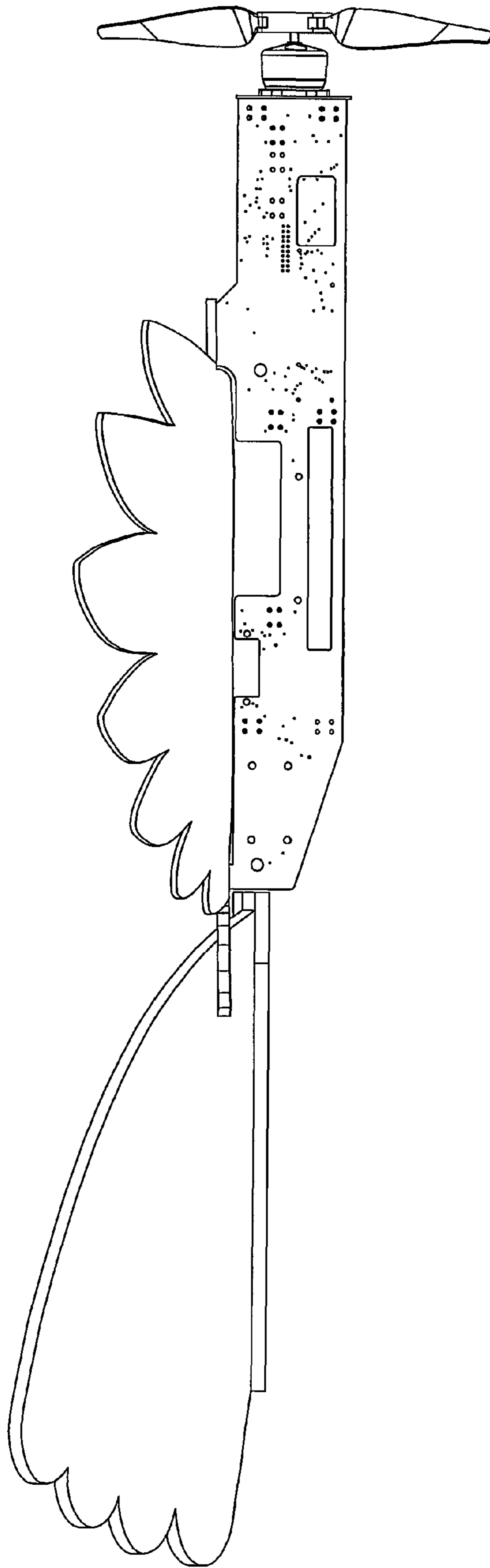

FIG. 5

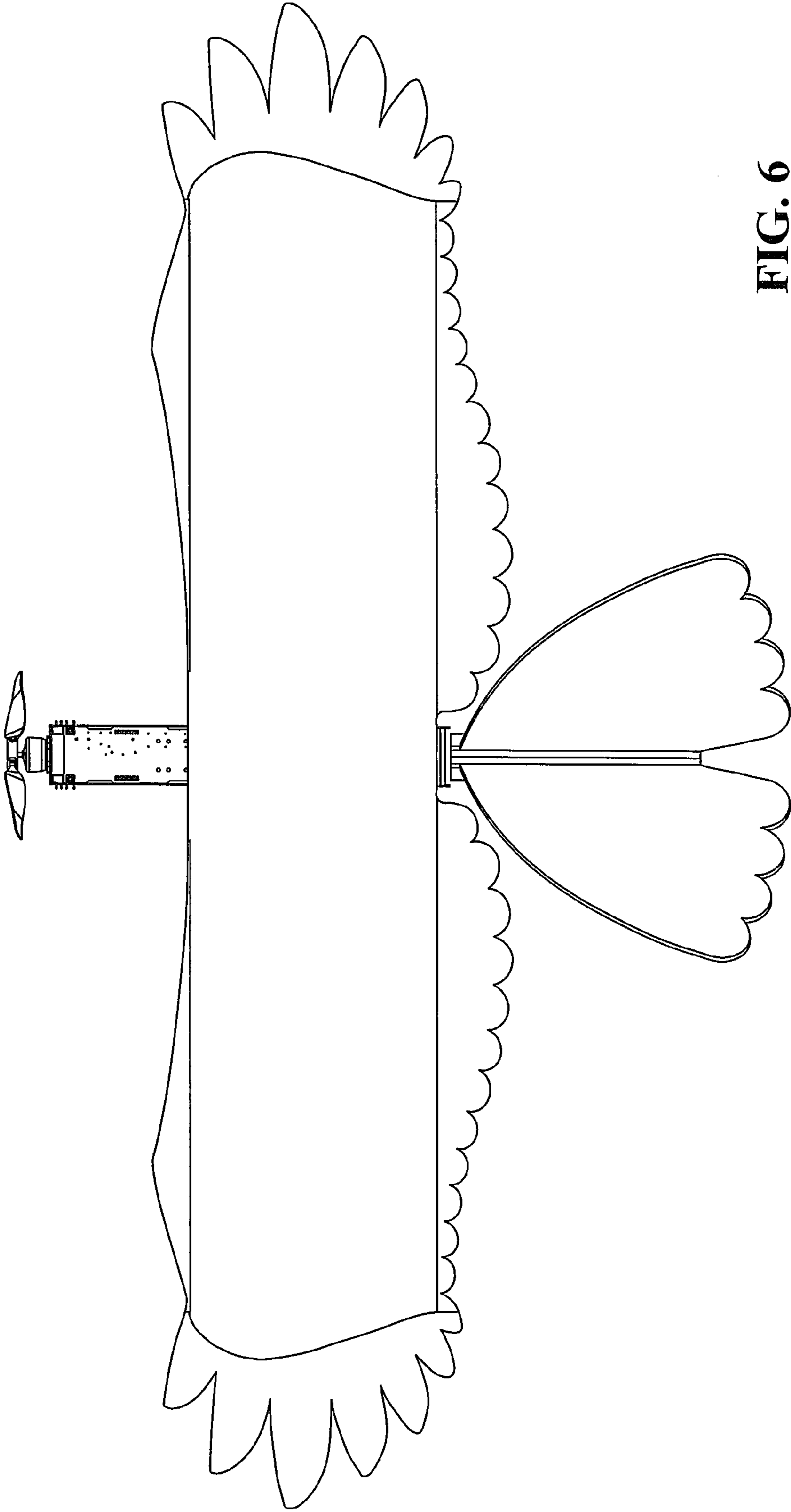

FIG. 6



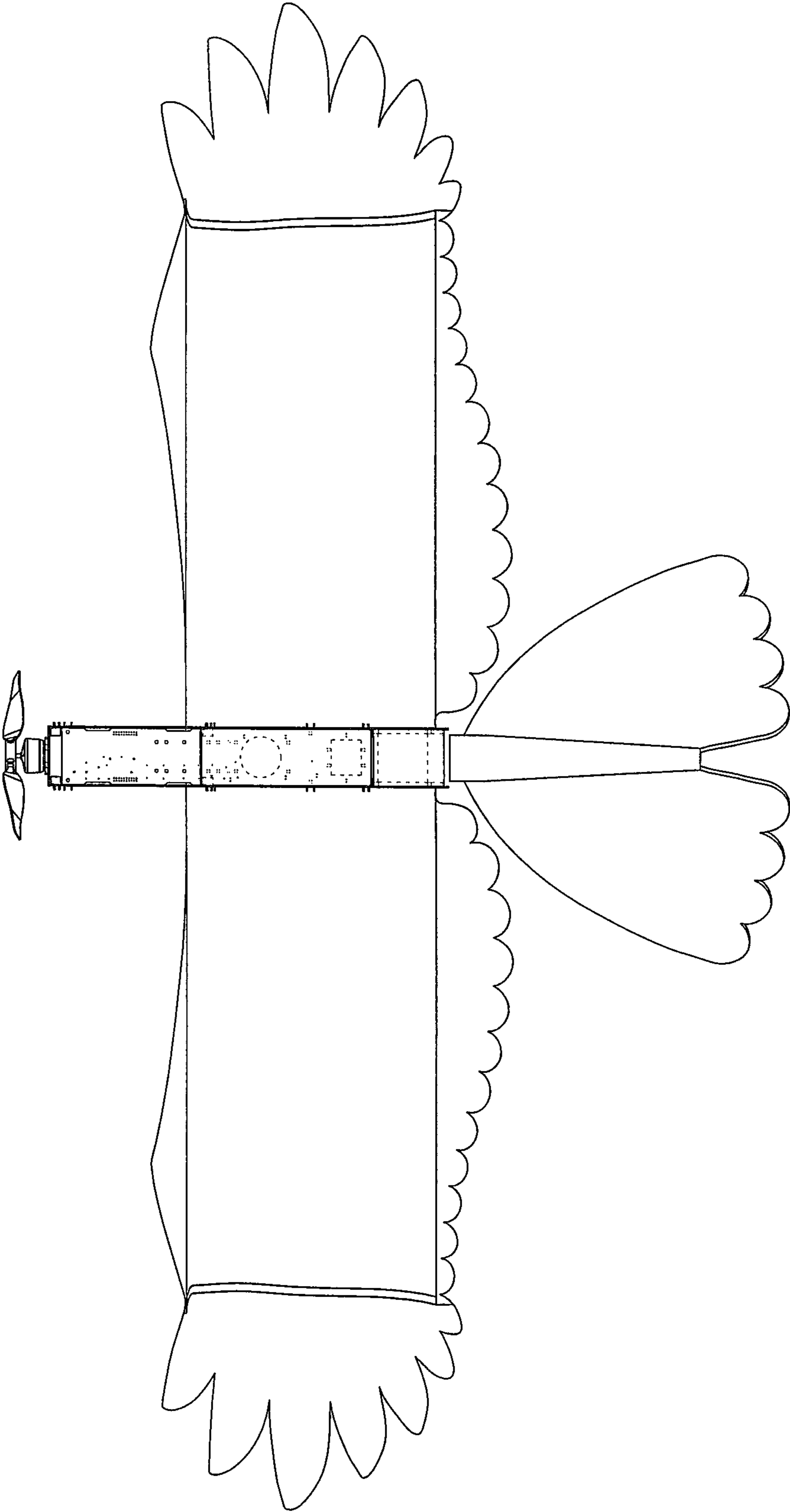

FIG.7