



US00D729698S

(12) **United States Design Patent**  
**Chen**

(10) **Patent No.:** **US D729,698 S**

(45) **Date of Patent:** **\*\* May 19, 2015**

(54) **ONE-WHEELED VEHICLE**

(71) Applicant: **Shane Chen**, Camas, WA (US)

(72) Inventor: **Shane Chen**, Camas, WA (US)

(\*\*) Term: **14 Years**

(21) Appl. No.: **29/459,582**

(22) Filed: **Jul. 1, 2013**

(51) **LOC (10) Cl.** ..... **12-11**

(52) **U.S. Cl.**  
USPC ..... **D12/107**

(58) **Field of Classification Search**

CPC ..... B62K 1/00; B62K 3/007; B62K 7/0007;  
B62D 61/00; B62H 1/12

USPC ..... D12/107, 111, 108, 124, 109, 113, 112;  
280/205, 1.13, 208, 304.5, 283, 276,  
280/240, 381.1, 284, 256, 286, 265, 268,  
280/271, 288, 257, 279, 288.2, 288.4, 210,  
280/287, 278; 180/21, 65.51, 220, 68.5;  
701/22; D21/432, 419, 663, 435, 662;  
74/594.3, 527; 16/44; 156/294; 29/428;  
224/419

See application file for complete search history.

(56) **References Cited**

**U.S. PATENT DOCUMENTS**

|           |      |         |                 |           |
|-----------|------|---------|-----------------|-----------|
| 4,109,741 | A *  | 8/1978  | Gabriel         | 180/21    |
| 4,324,413 | A *  | 4/1982  | Bensette et al. | 280/205   |
| D481,771  | S *  | 11/2003 | Anderson        | D21/682   |
| D624,136  | S *  | 9/2010  | Chen            | D21/760   |
| D624,137  | S *  | 9/2010  | Chen            | D21/760   |
| D626,892  | S *  | 11/2010 | Shin            | D12/107   |
| D654,545  | S *  | 2/2012  | Richard         | D21/662   |
| D671,998  | S *  | 12/2012 | Rodriguez, Jr.  | D21/686   |
| D673,081  | S *  | 12/2012 | Chen            | D12/107   |
| D685,295  | S *  | 7/2013  | Mori et al.     | D12/107   |
| 8,613,453 | B2 * | 12/2013 | Chen            | 280/11.24 |
| 8,800,697 | B2 * | 8/2014  | Hoffmann et al. | 180/21    |
| 8,807,250 | B2 * | 8/2014  | Chen            | 180/21    |

|              |      |         |                 |           |
|--------------|------|---------|-----------------|-----------|
| 2006/0279057 | A1 * | 12/2006 | Shimizu et al.  | 280/205   |
| 2011/0056757 | A1 * | 3/2011  | Polutnik        | 180/65.51 |
| 2011/0175319 | A1 * | 7/2011  | Chen            | 280/205   |
| 2011/0220427 | A1 * | 9/2011  | Chen            | 180/21    |
| 2012/0217072 | A1 * | 8/2012  | Hoffmann et al. | 180/21    |
| 2014/0058600 | A1 * | 2/2014  | Hoffmann et al. | 701/22    |
| 2014/0196962 | A1 * | 7/2014  | Hoffmann et al. | 180/21    |

\* cited by examiner

*Primary Examiner* — Robert M Spear

*Assistant Examiner* — Ryan Harvey

(57) **CLAIM**

The ornamental design for a one-wheeled vehicle, as shown and described.

**DESCRIPTION**

FIG. 1 is a top view of the first embodiment of the one-wheeled vehicle.

FIG. 2 is a left view of the vehicle of FIG. 1; the left and right views are mirror images.

FIG. 3 is a rear elevational view of the vehicle of FIG. 1.

FIG. 4 is a bottom view of the vehicle of FIG. 1.

FIG. 5 is a front elevational view of the vehicle of FIG. 1.

FIG. 6 is a perspective view of the vehicle of FIG. 1.

FIG. 7 is a top view of the second embodiment of the one-wheeled vehicle.

FIG. 8 is a left view of the vehicle of FIG. 7; the left and right views are mirror images.

FIG. 9 is a rear elevational view of the vehicle of FIG. 7.

FIG. 10 is a bottom view of the vehicle of FIG. 7.

FIG. 11 is a front elevational view of the vehicle of FIG. 7; and,

FIG. 12 is a perspective view of the vehicle of FIG. 7.

The objects outlined in broken lines near the bottom of the device represent functional components which are provided for context and not part of the claimed design. All other broken lines represent the bounds of the claimed design, wherein the details of the enclosed surfaces are not claimed.

**1 Claim, 4 Drawing Sheets**

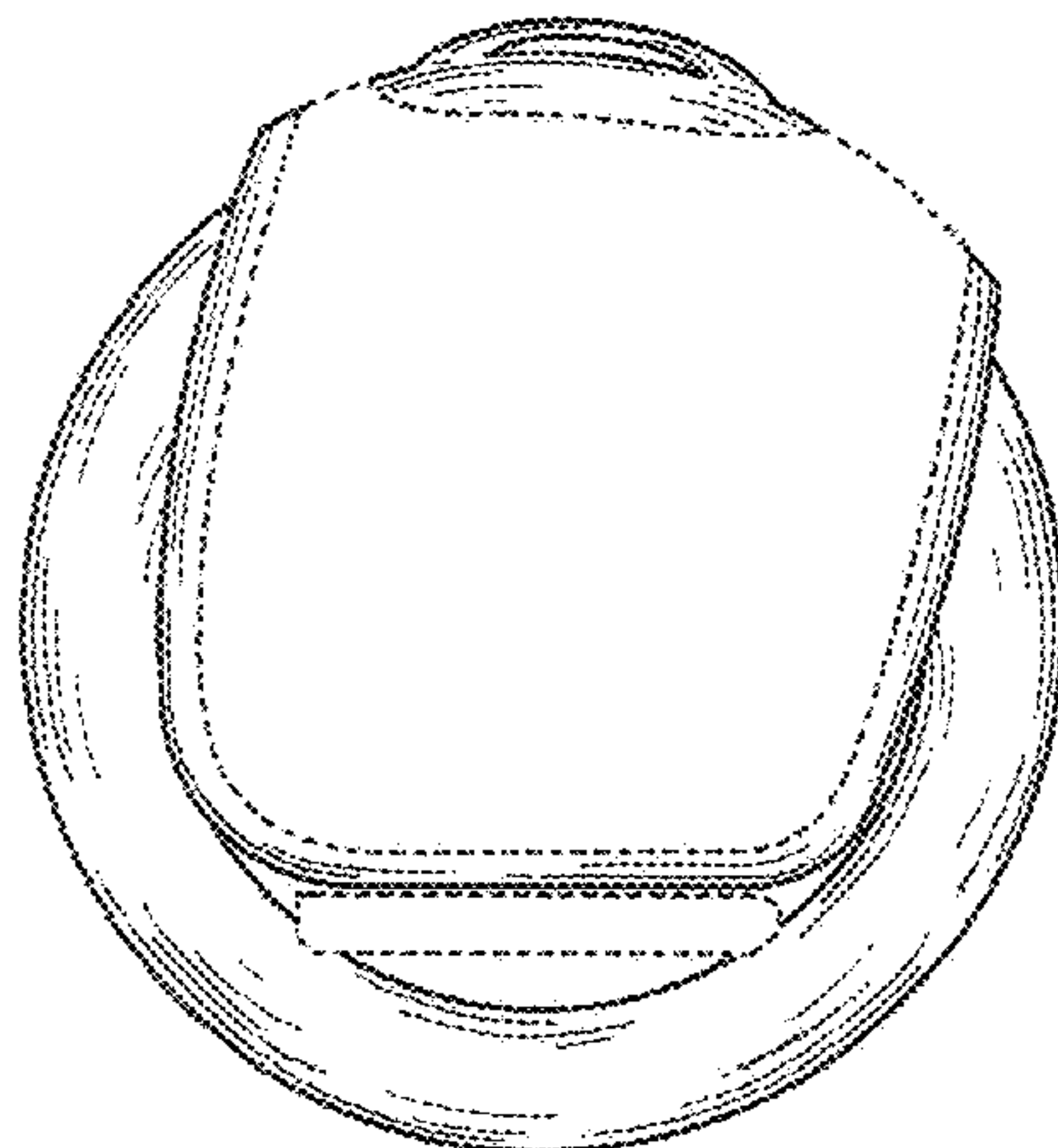

Fig. 1

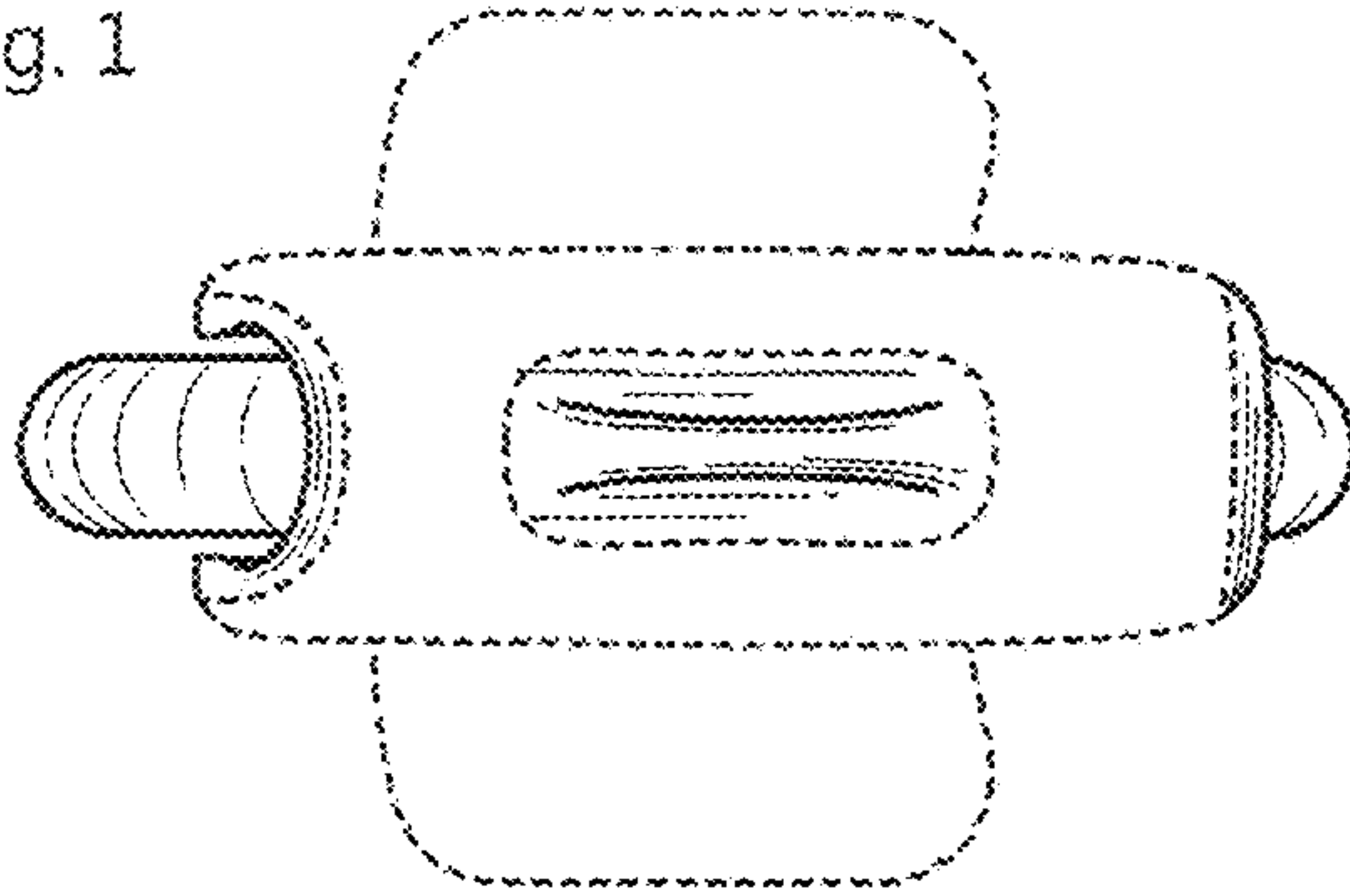

Fig. 2

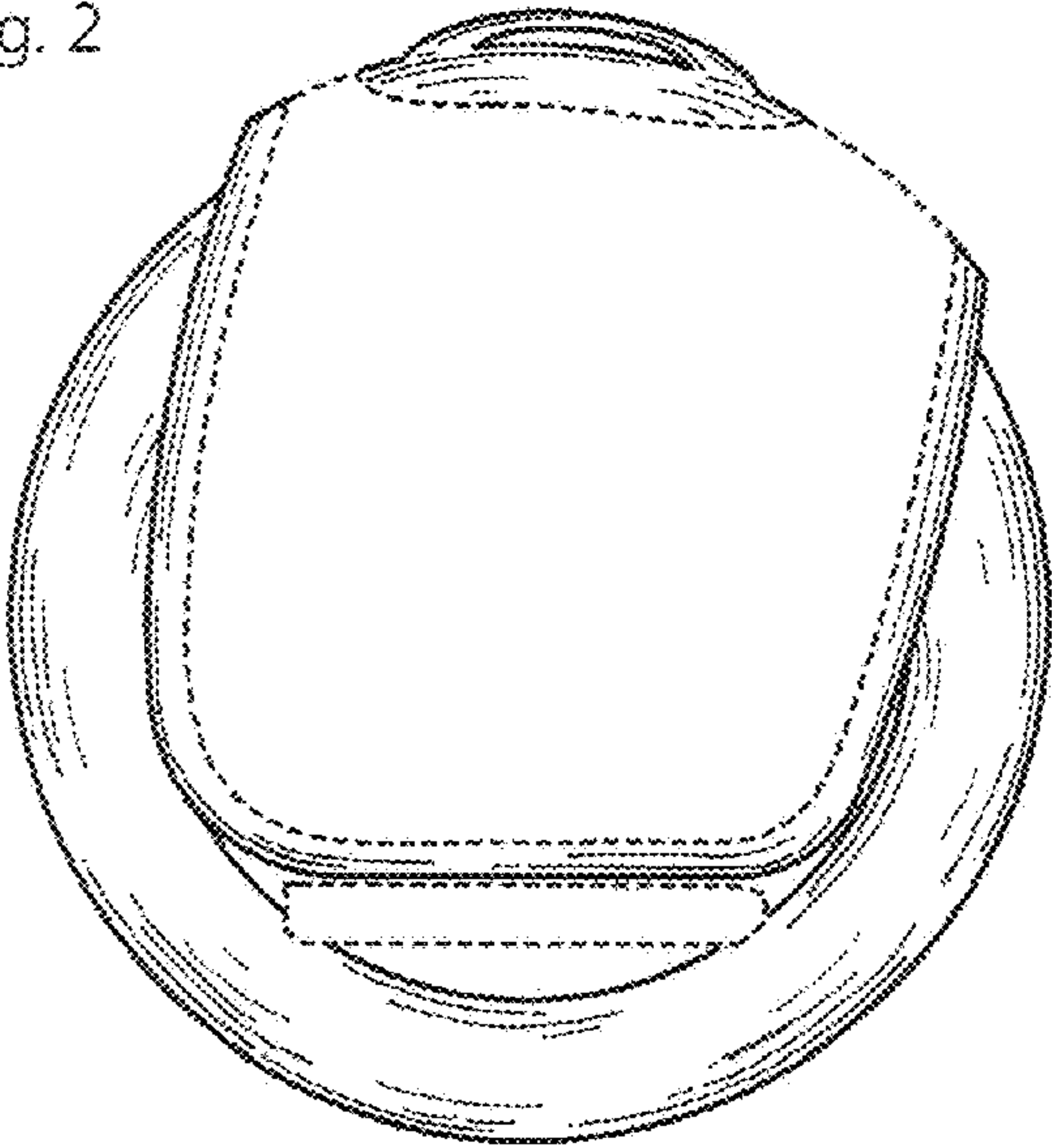

Fig. 3

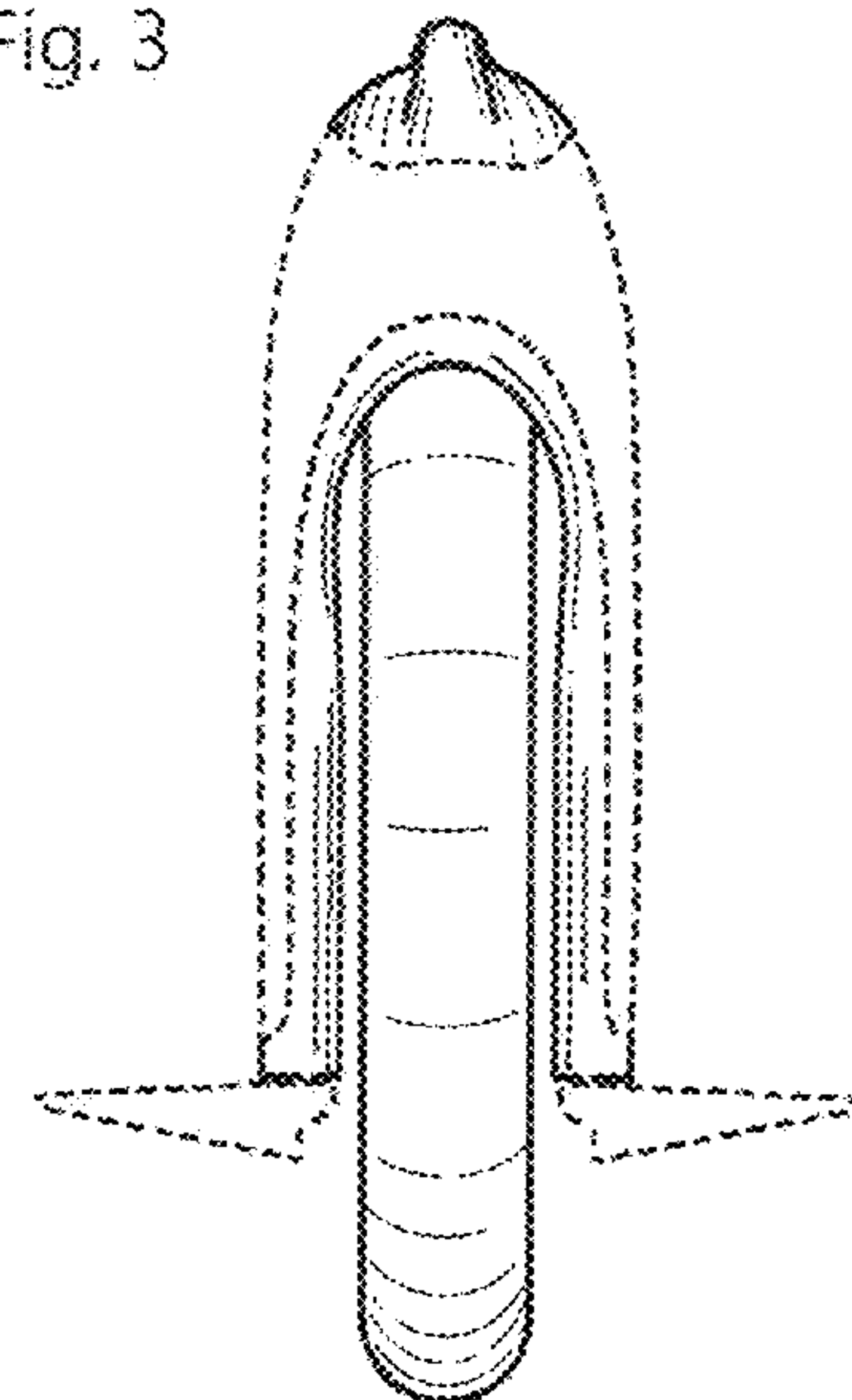

Fig. 4

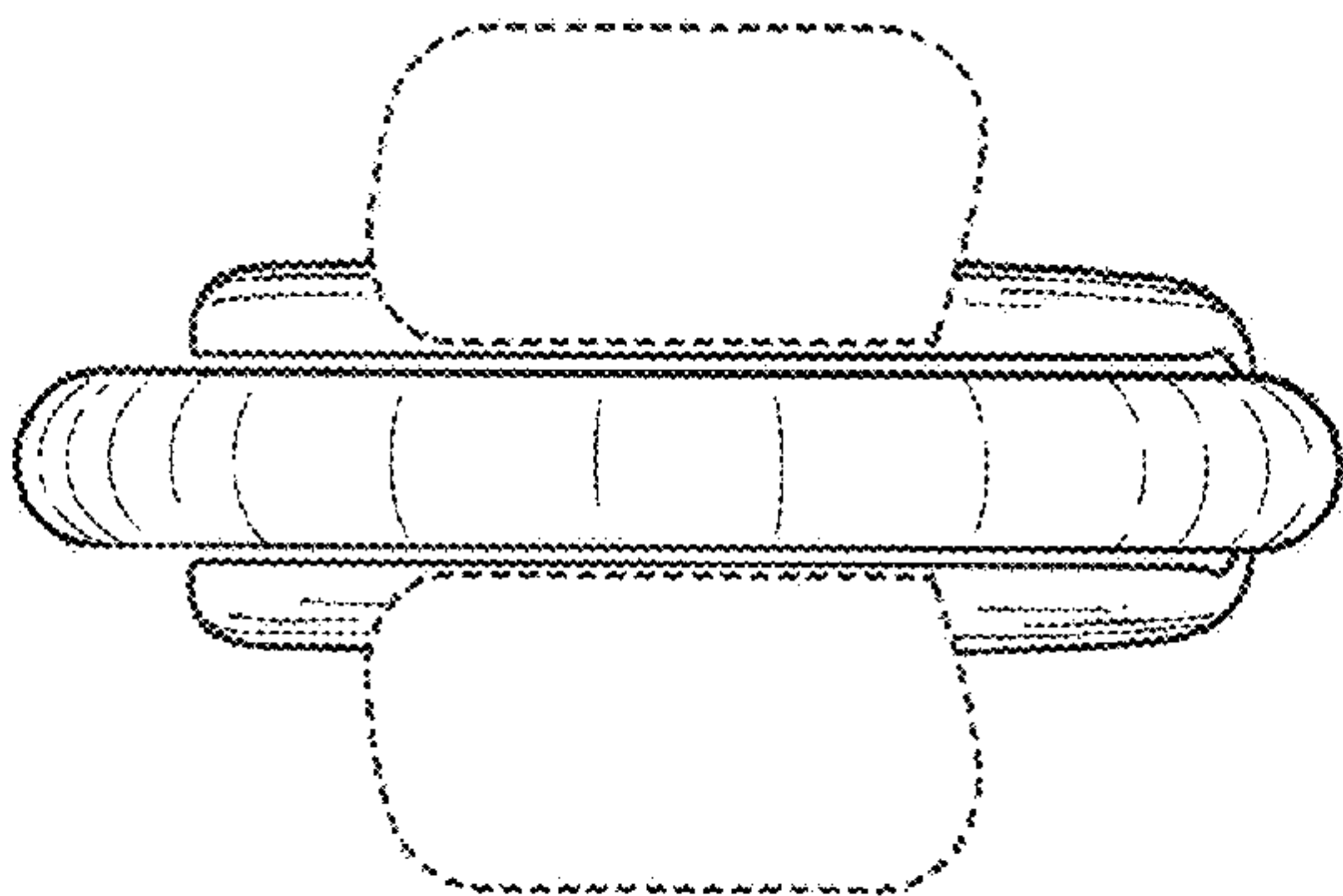

Fig. 5

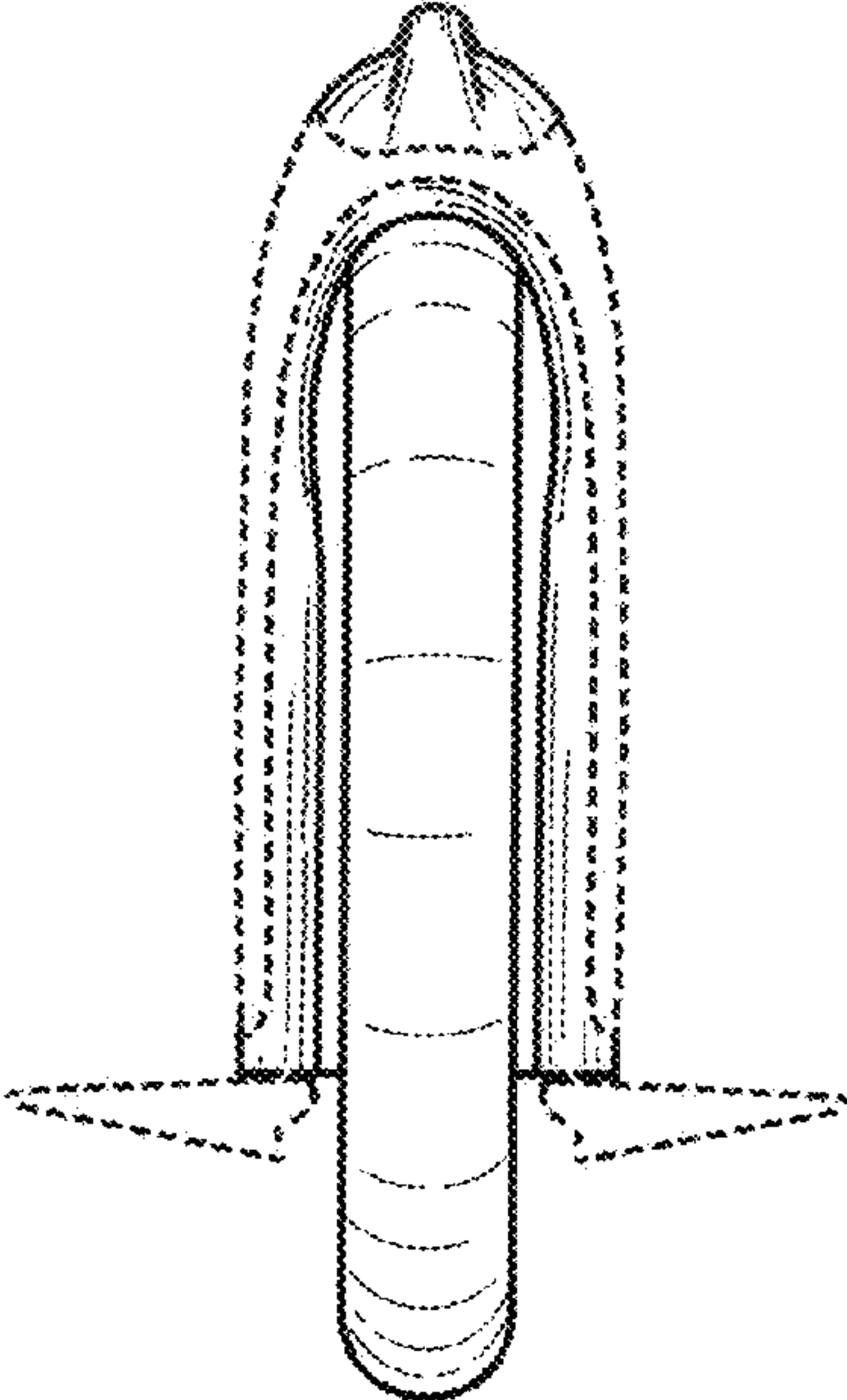

Fig. 6

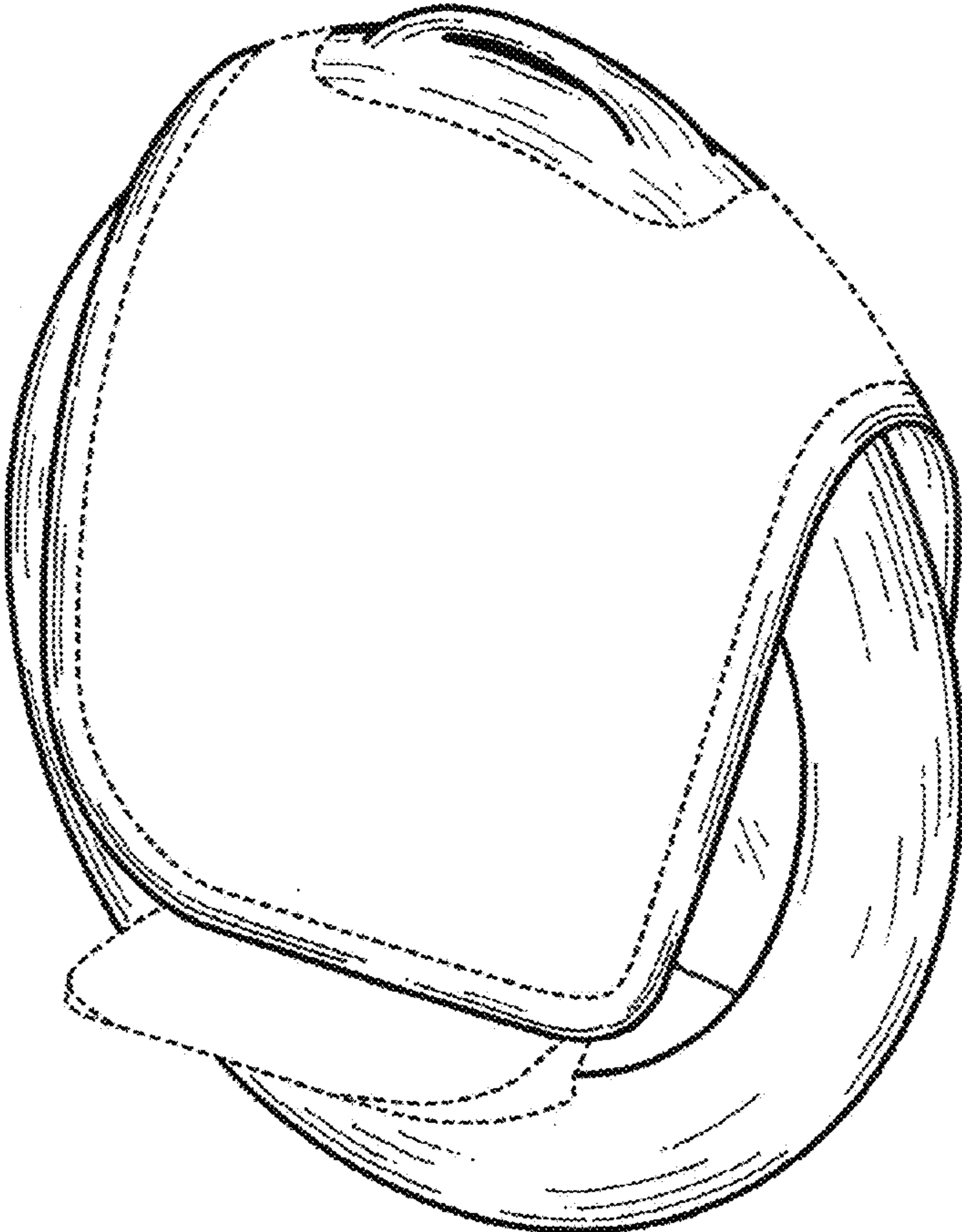



Fig. 7

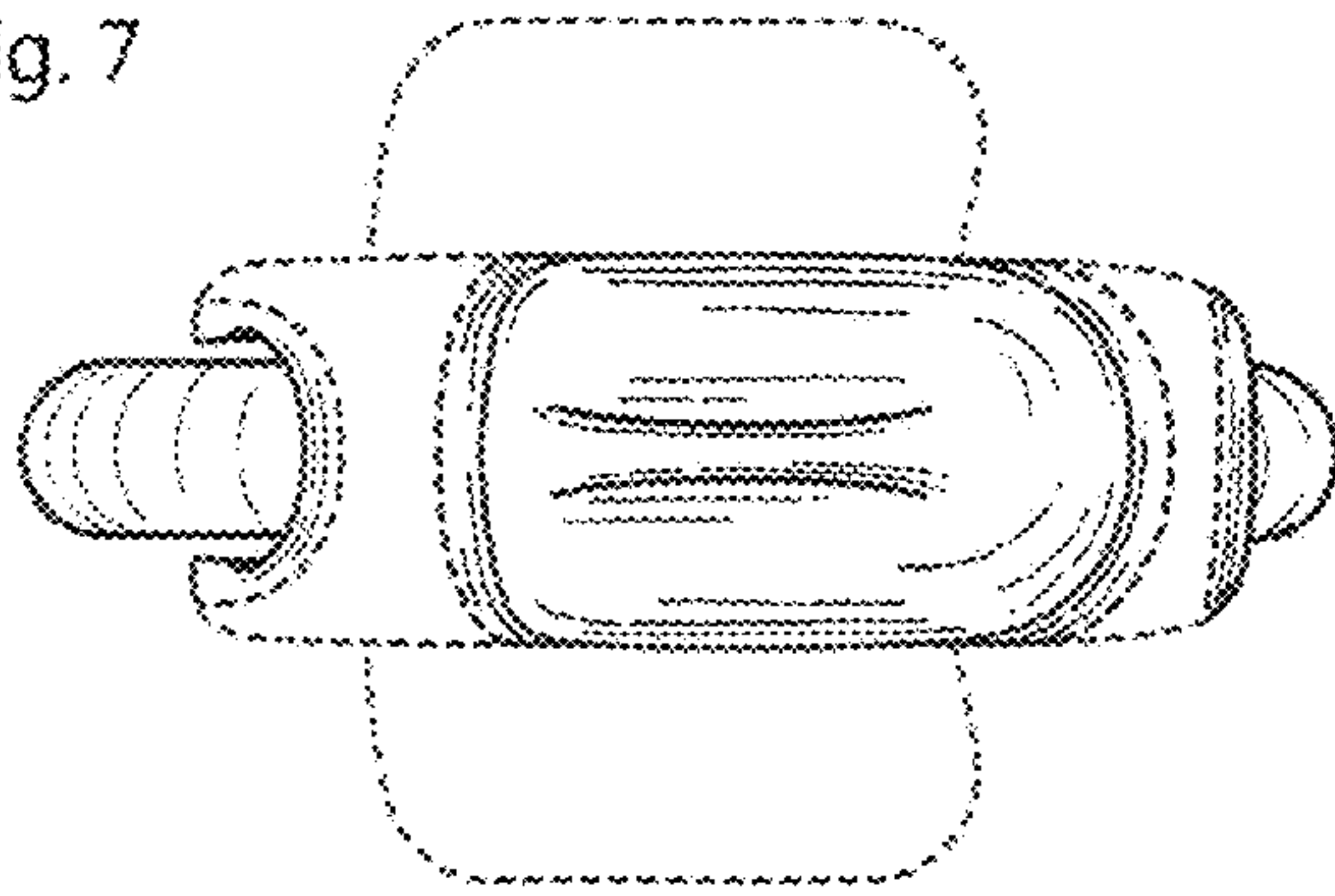

Fig. 8

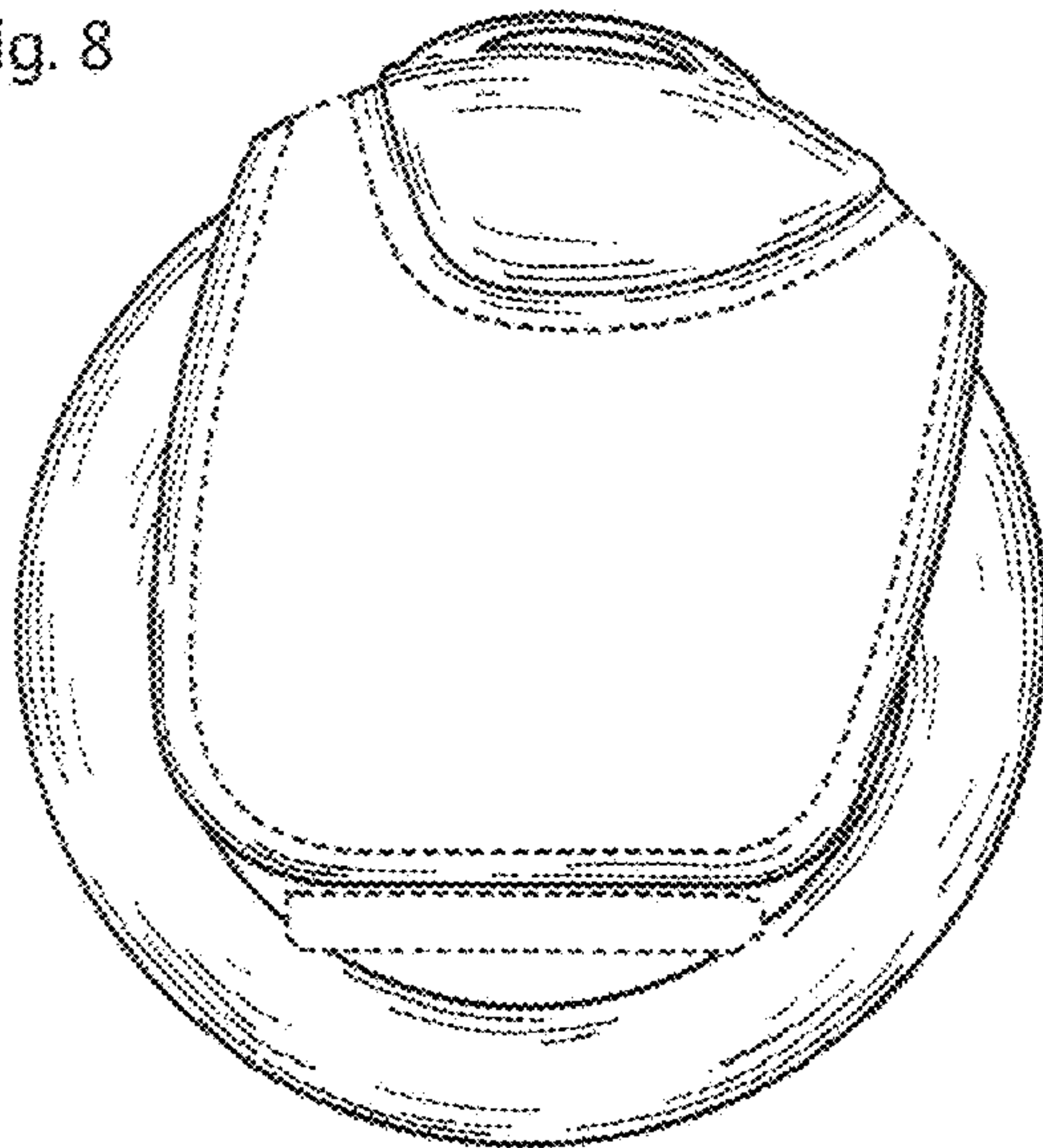

Fig. 9

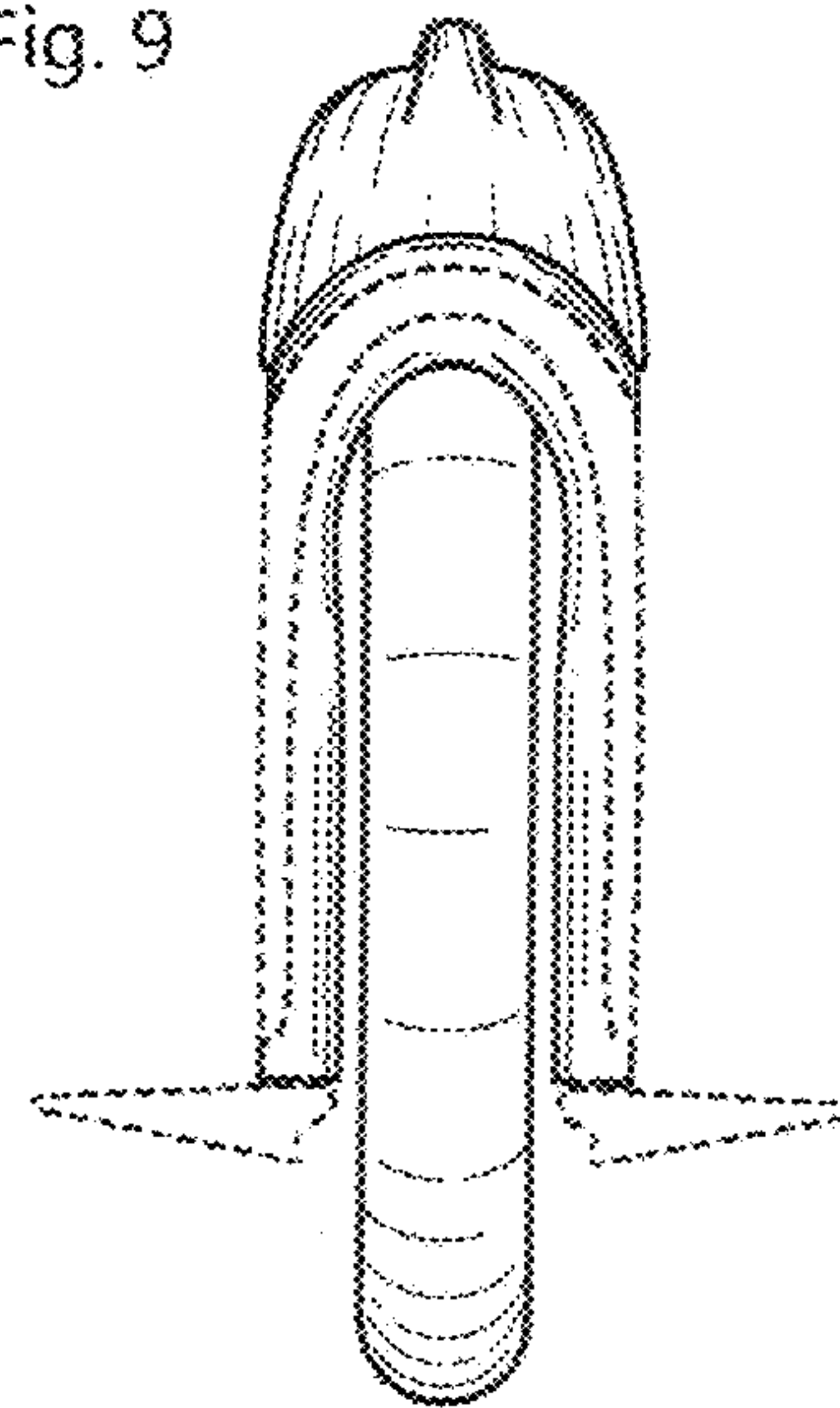

Fig. 10

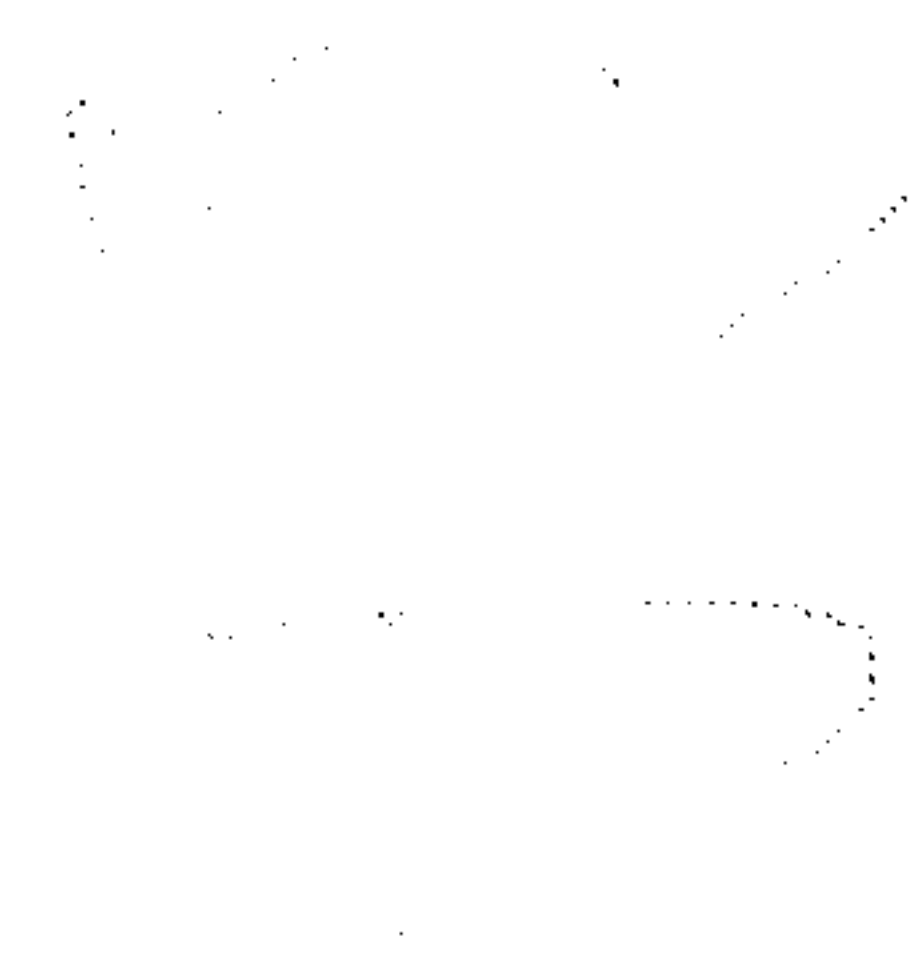
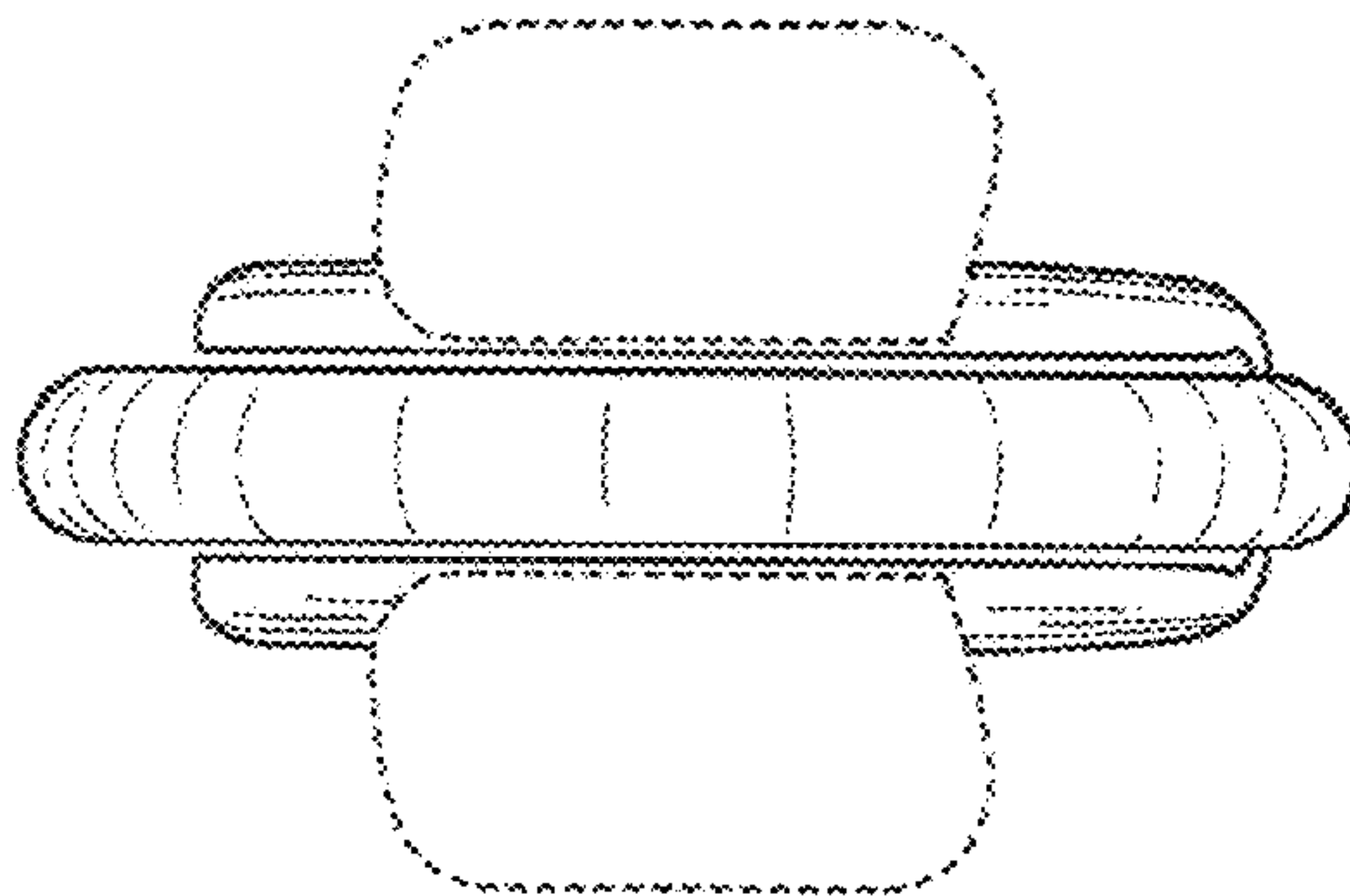

Fig. 11

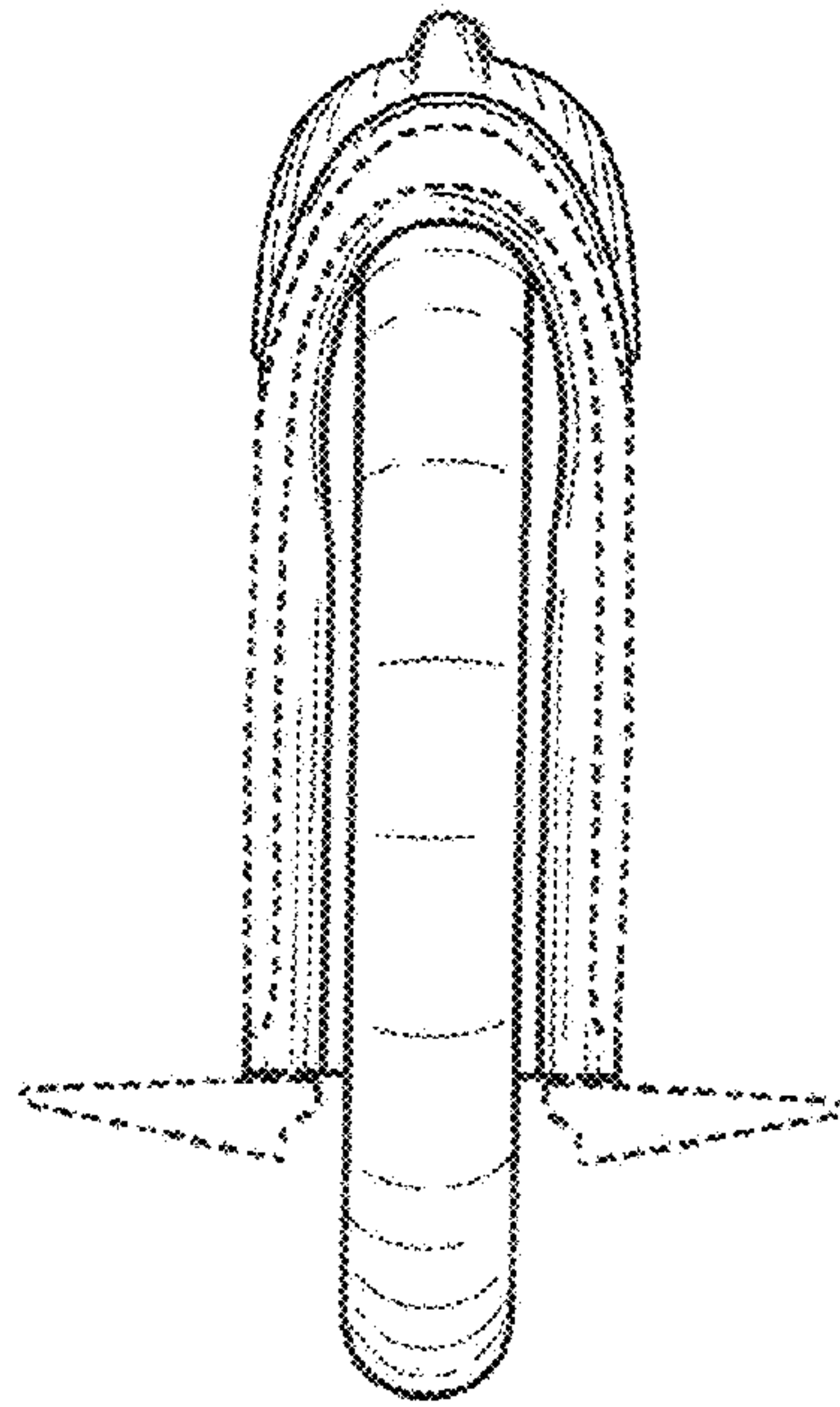

Fig. 12

