



US00D729398S

(12) **United States Design Patent**
Park

(10) **Patent No.:** **US D729,398 S**

(45) **Date of Patent:** **** May 12, 2015**

(54) **RECHARGEABLE DUAL MASSAGER**

(71) Applicant: **Homelec Korea Co., Ltd.**, Seoul (KR)

(72) Inventor: **Kunwoo Park**, Gyeonggi-do (KR)

(73) Assignee: **Homelec Korea Co., Ltd.**, Seoul (KR)

(**) Term: **14 Years**

(21) Appl. No.: **29/493,555**

(22) Filed: **Jun. 11, 2014**

(30) **Foreign Application Priority Data**

Apr. 11, 2014 (KR) 30-2014-0018338

(51) **LOC (10) Cl.** **28-03**

(52) **U.S. Cl.**
USPC **D24/215**

(58) **Field of Classification Search**
USPC D24/200, 211, 212, 213, 214, 215;
601/19, 27-32, 46, 49, 52, DIG. 12,
601/DIG. 14, DIG. 15, DIG. 16, DIG. 17, 48
See application file for complete search history.

(56) **References Cited**

U.S. PATENT DOCUMENTS

D301,617 S *	6/1989	Yonesawa et al.	D24/211
D311,955 S *	11/1990	Lie	D24/211
D323,034 S *	1/1992	Reinstein	D24/206
D333,351 S *	2/1993	Tsou	D24/206
D351,660 S *	10/1994	Ichikawa et al.	D24/214
D362,307 S *	9/1995	Cirone	D24/211

D391,645 S *	3/1998	Chien	D24/211
D410,549 S *	6/1999	Chen	D24/211
D435,913 S *	1/2001	Harris et al.	D24/215
D478,385 S *	8/2003	Dirks et al.	D24/215
6,730,050 B2 *	5/2004	Huang	601/93
D556,332 S *	11/2007	Han	D24/200
D623,311 S *	9/2010	Aulwes et al.	D24/214
D627,898 S *	11/2010	Aulwes et al.	D24/214
D628,304 S *	11/2010	Aulwes et al.	D24/214
D649,657 S *	11/2011	Petersen et al.	D24/215
D674,109 S *	1/2013	Sedic	D24/215
D685,491 S *	7/2013	Coral	D24/215
D692,571 S *	10/2013	Luzon et al.	D24/215
D695,364 S *	12/2013	Khalil	D21/662
2009/0069728 A1 *	3/2009	Hoffmann et al.	601/46

* cited by examiner

Primary Examiner — Sandra Snapp

(74) *Attorney, Agent, or Firm* — Rabin & Berdo, P.C.

(57) **CLAIM**

The ornamental design for a rechargeable dual massager, as shown and described.

DESCRIPTION

FIG. 1 is a perspective view of a rechargeable dual massager showing my new design;
FIG. 2 is a front elevational view thereof;
FIG. 3 is a rear elevational view thereof;
FIG. 4 is a left side view thereof;
FIG. 5 is a right side view thereof;
FIG. 6 is a top view thereof; and,
FIG. 7 is a bottom view thereof.

1 Claim, 6 Drawing Sheets

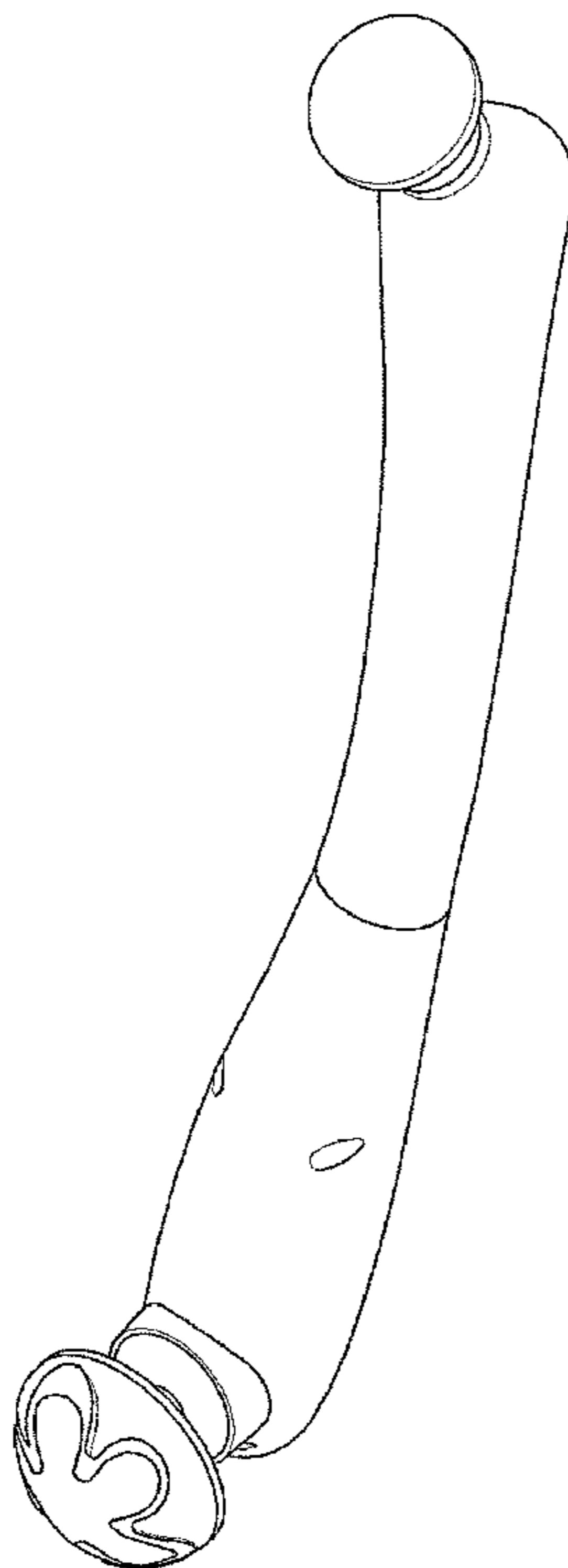

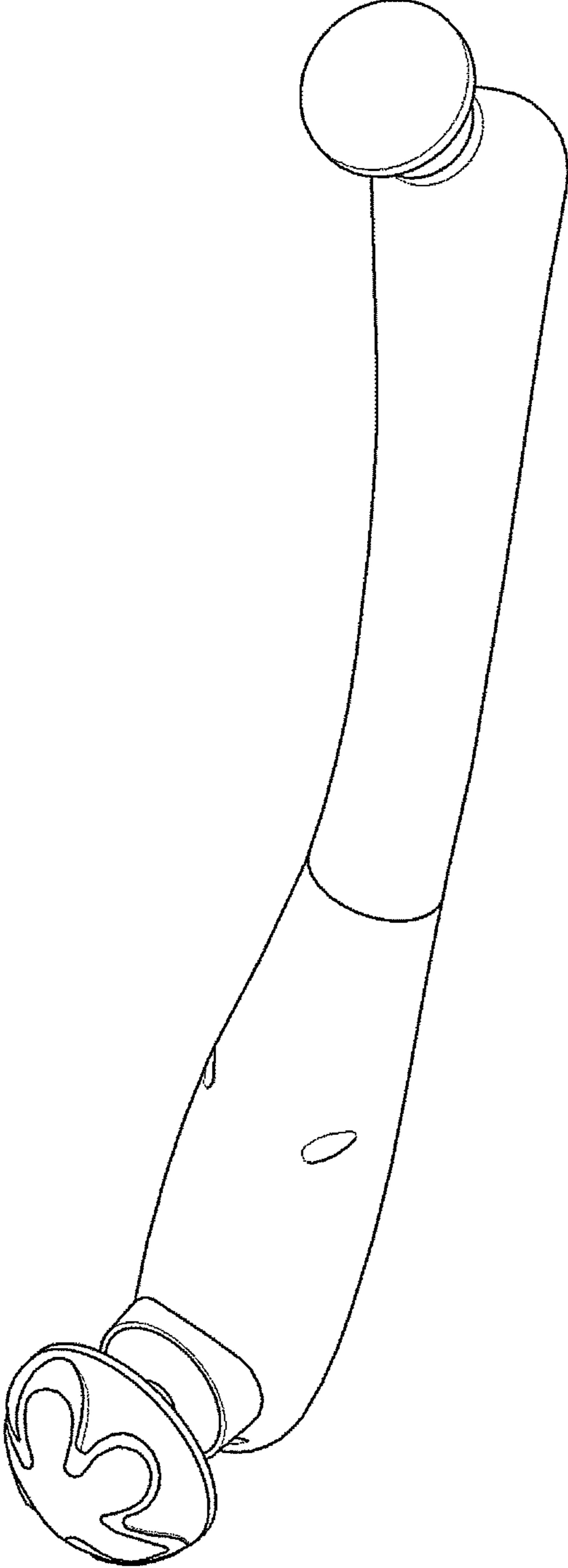

FIG. 1

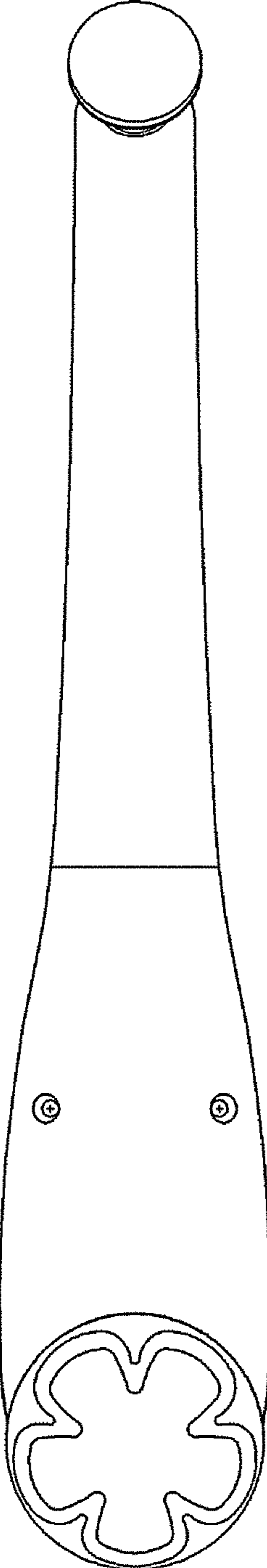

FIG. 2

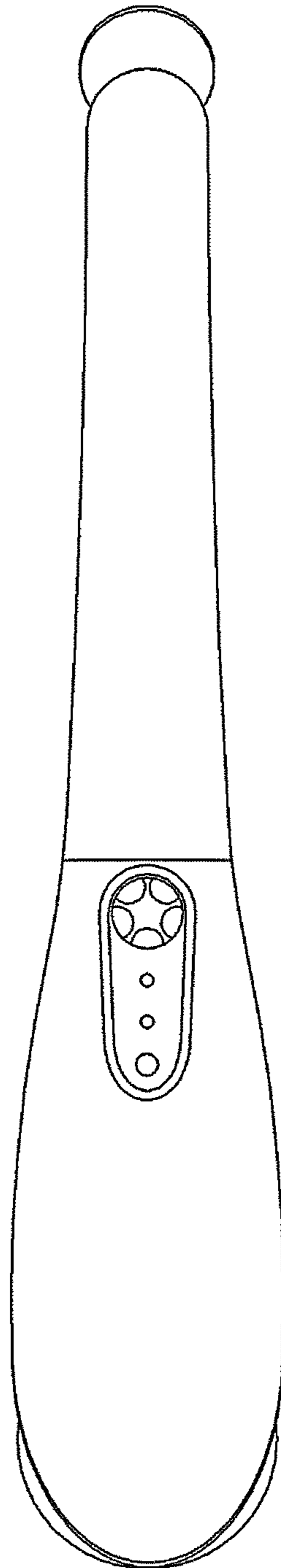

FIG. 3

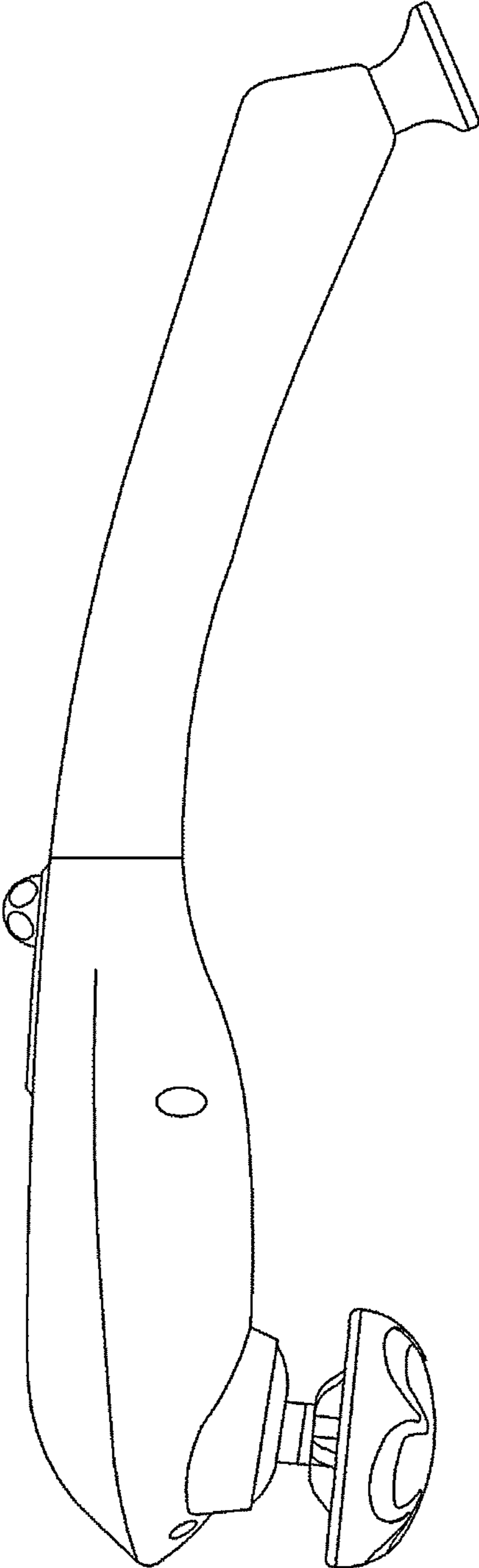

FIG. 4

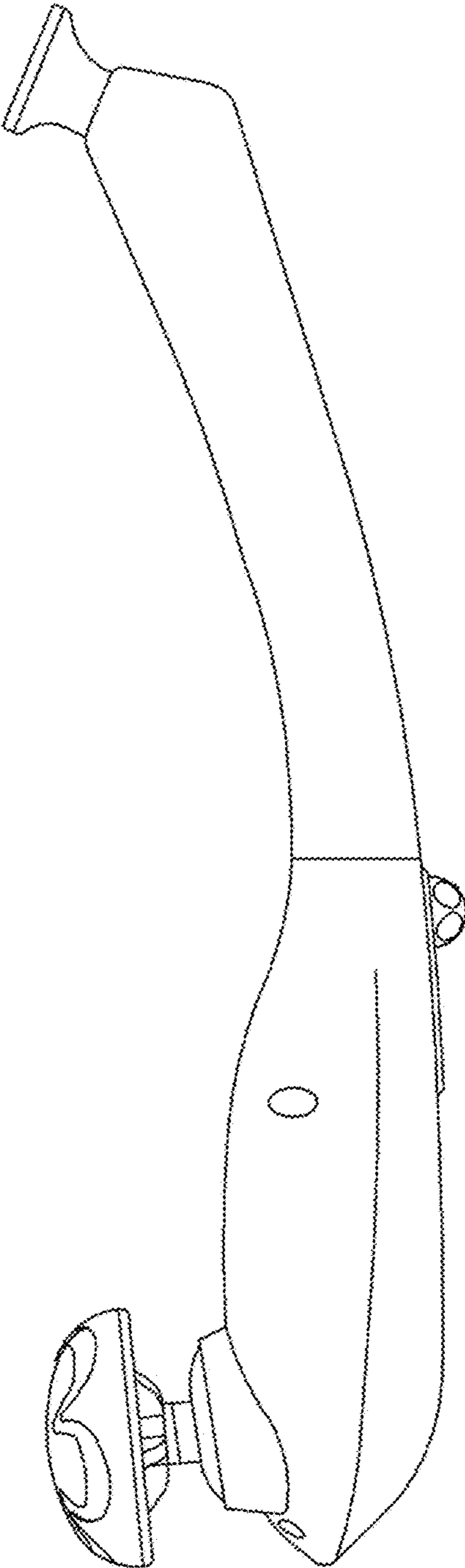

FIG. 5

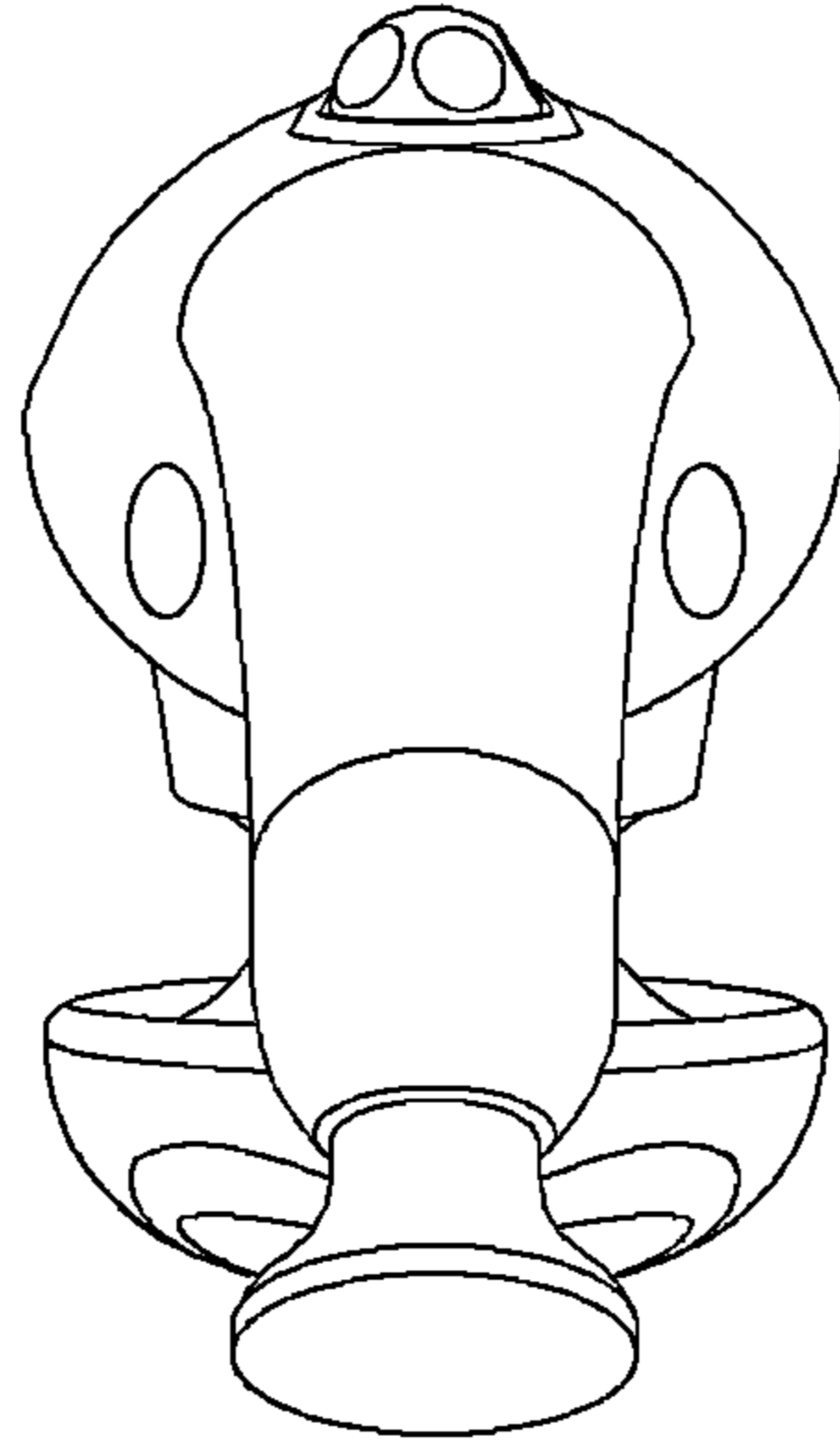

FIG. 6

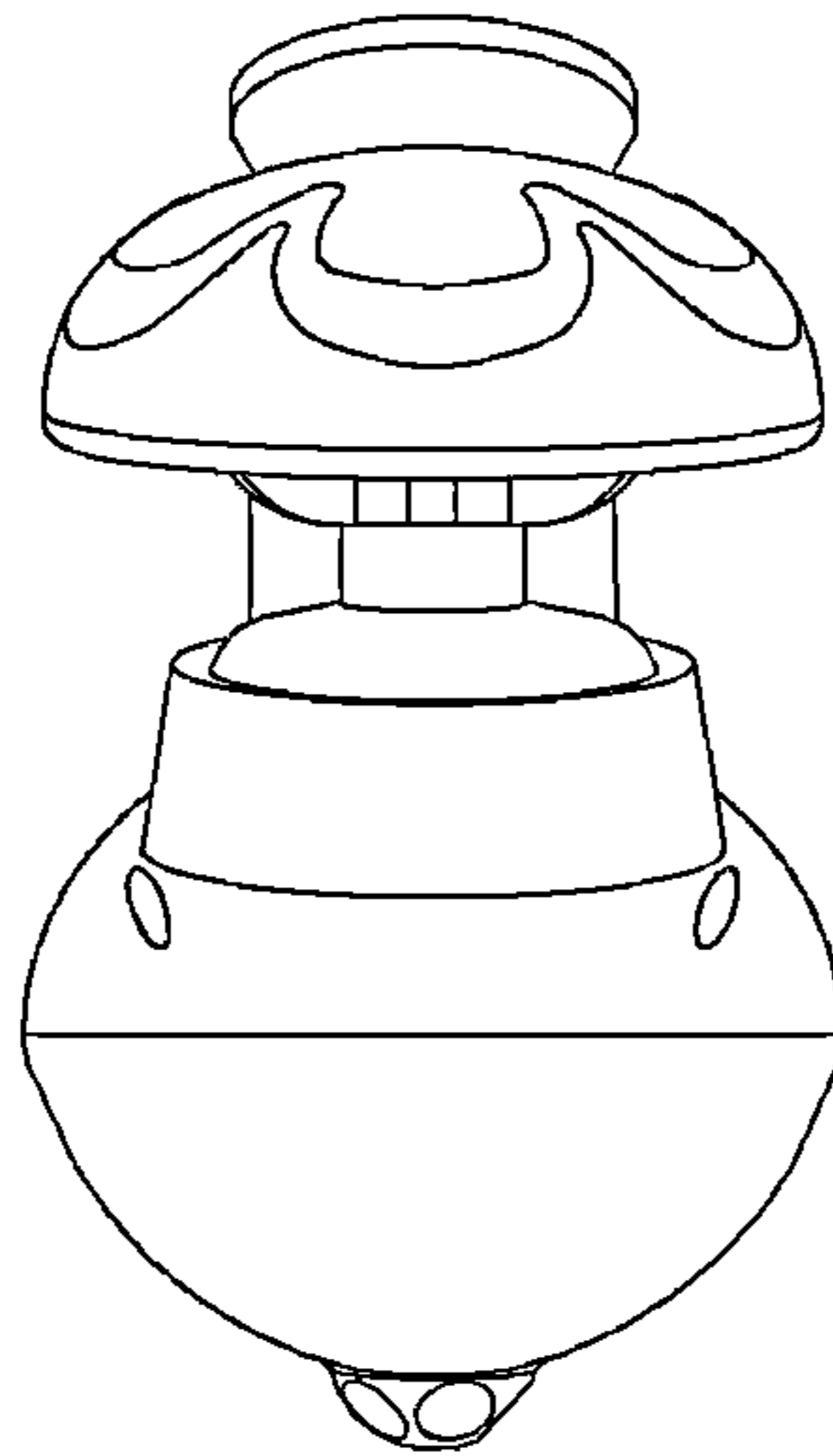

FIG. 7