



US00D729148S

(12) **United States Design Patent**
Kotoku

(10) **Patent No.:** **US D729,148 S**

(45) **Date of Patent:** **** May 12, 2015**

(54) **AUTOMOBILE TIRE**

(56) **References Cited**

(71) Applicant: **The Yokohama Rubber Co., Ltd.**,
Minato-ku, Tokyo (JP)

(72) Inventor: **Koichi Kotoku**, Hiratsuka (JP)

(73) Assignee: **The Yokohama Rubber Co., Ltd.**,
Minato-ku, Tokyo (JP)

(**) Term: **14 Years**

(21) Appl. No.: **29/448,413**

(22) Filed: **Mar. 12, 2013**

(30) **Foreign Application Priority Data**

Sep. 12, 2012 (JP) 2012-022128

(51) **LOC (10) Cl.** **12-15**

(52) **U.S. Cl.**
USPC **D12/574**

(58) **Field of Classification Search**
CPC B60C 1/00
USPC D12/568-603; 152/209.1-209.28
See application file for complete search history.

U.S. PATENT DOCUMENTS

D194,202 S * 12/1962 Tiborez D12/574
D615,026 S * 5/2010 Nakano D12/582
D652,367 S * 1/2012 Lange et al. D12/574

* cited by examiner

Primary Examiner — George D Kirschbaum

(74) *Attorney, Agent, or Firm* — Banner & Witcoff, Ltd.

(57) **CLAIM**

The ornamental design for an automobile tire, as shown and described.

DESCRIPTION

FIG. 1 is a perspective view of front and right side of an automobile tire showing my new design;
FIG. 2 is a front view thereof;
FIG. 3 is a rear view thereof;
FIG. 4 is a left side view thereof;
FIG. 5 is a right side view thereof;
FIG. 6 is a top view thereof;
FIG. 7 is a bottom view thereof; and,
FIG. 8 is an enlarged view at square portion of 8 in FIG. 1 thereof.

The broken lines are shown for illustrative purposes only and form no part of the claimed design. The tread pattern is understood to repeat uniformly throughout the circumference of the tire.

1 Claim, 8 Drawing Sheets

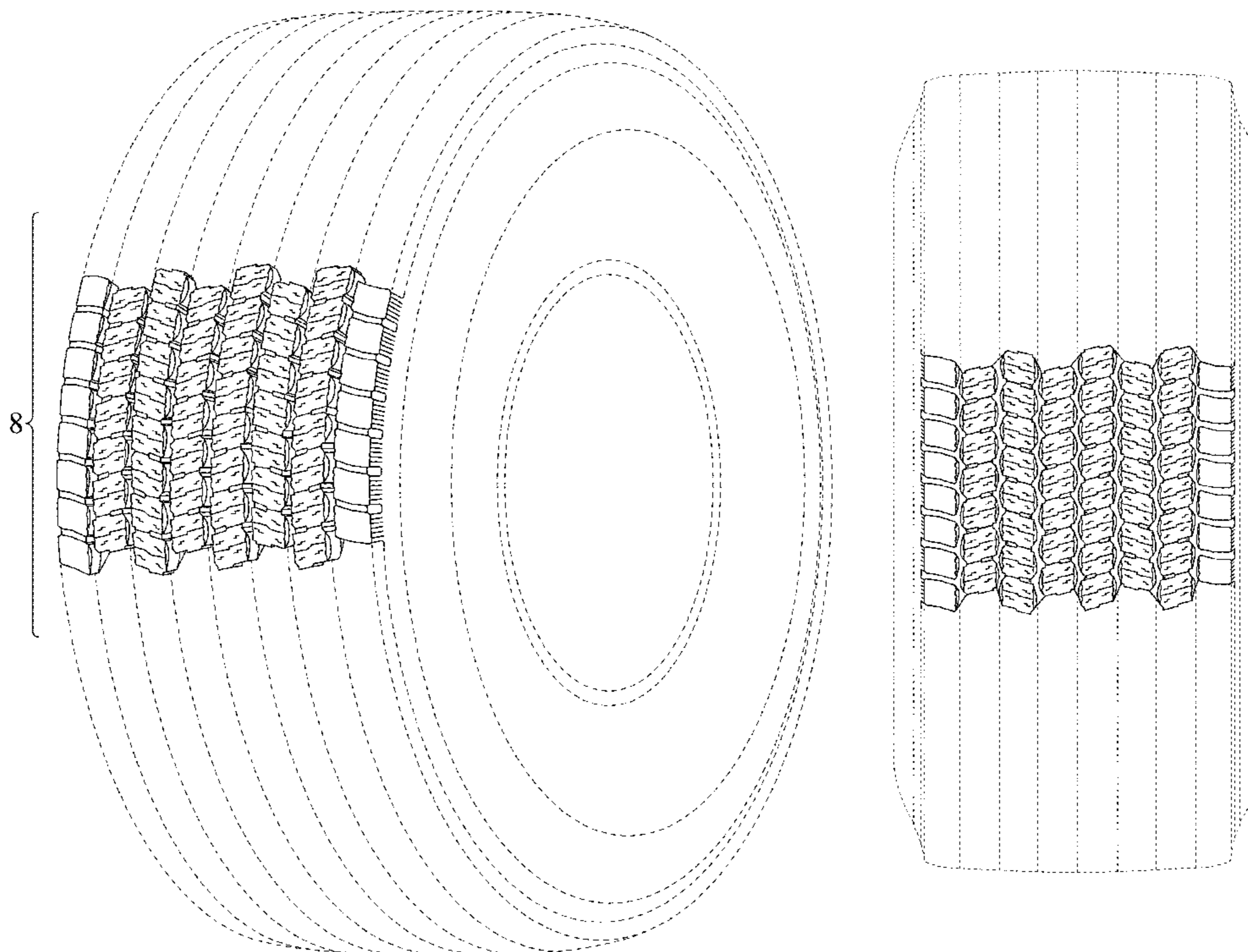

Fig. 1

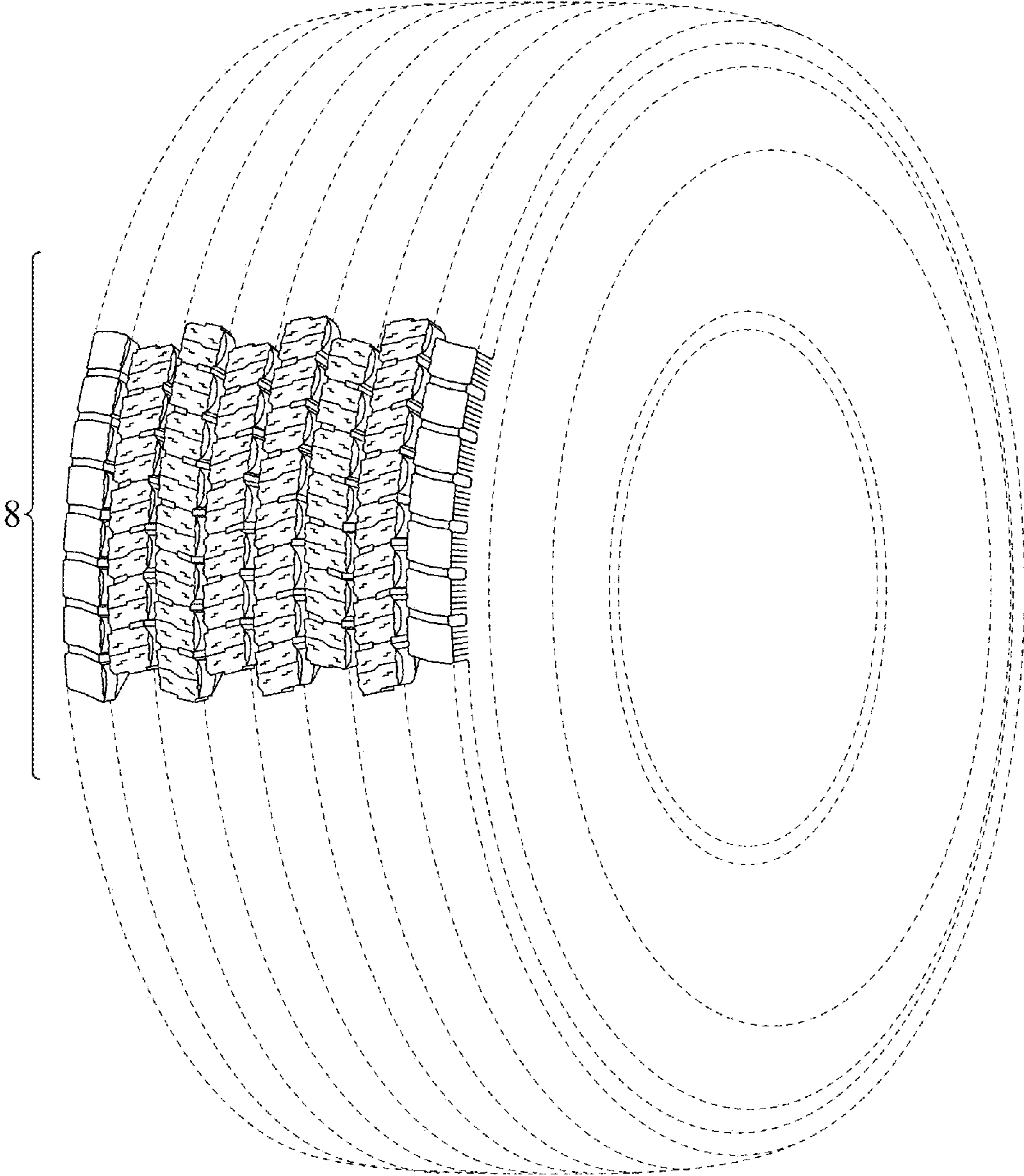

Fig. 2

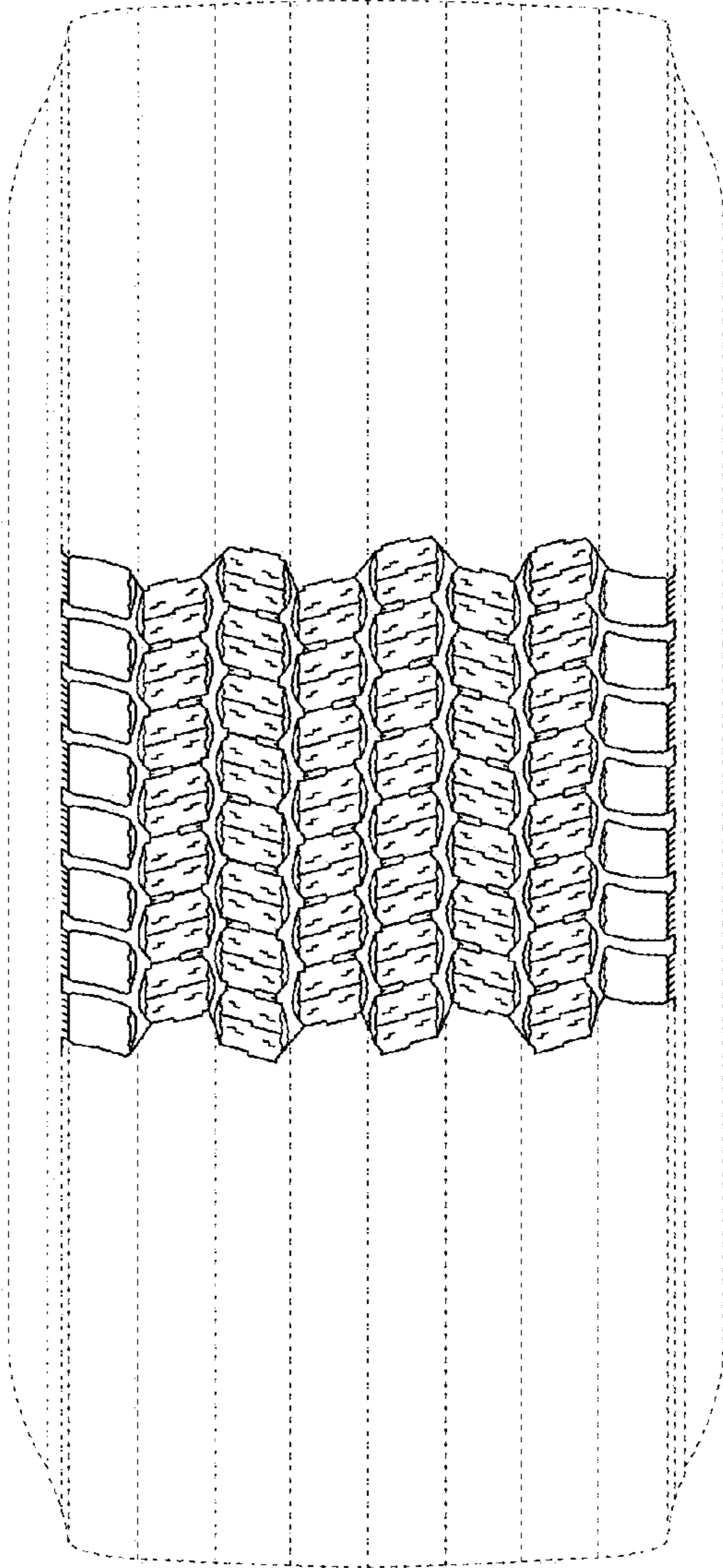

Fig. 3

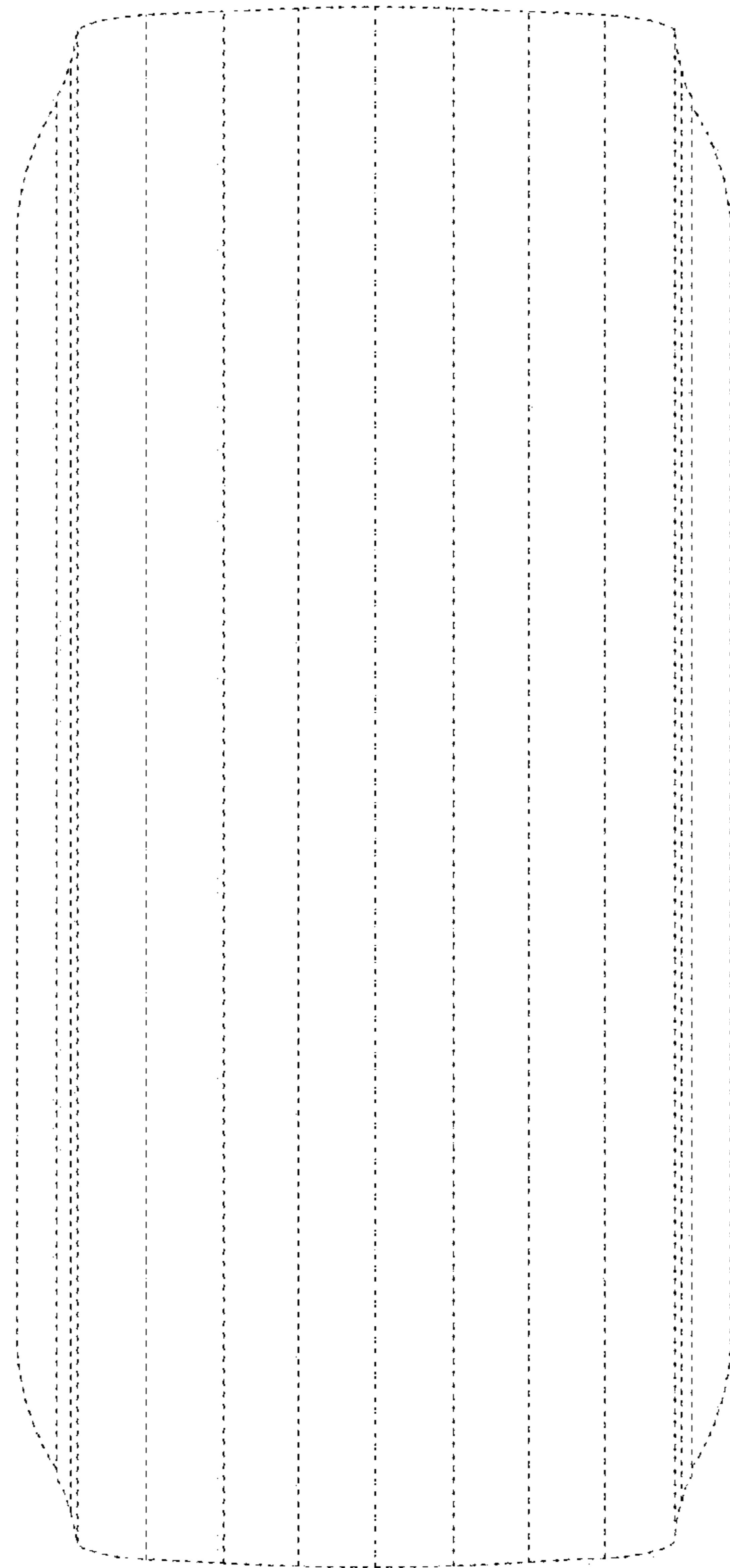

Fig. 4

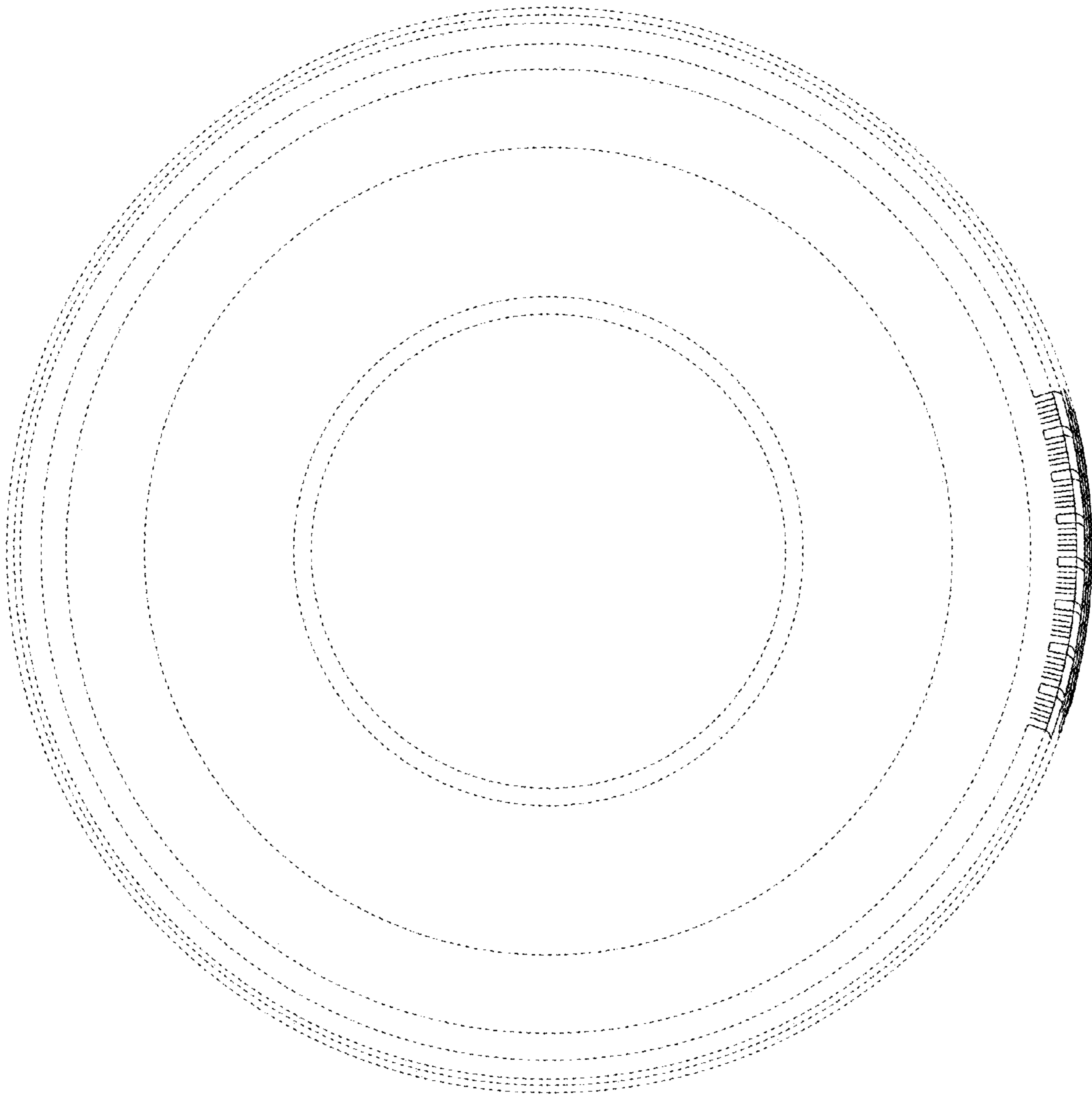

Fig. 5

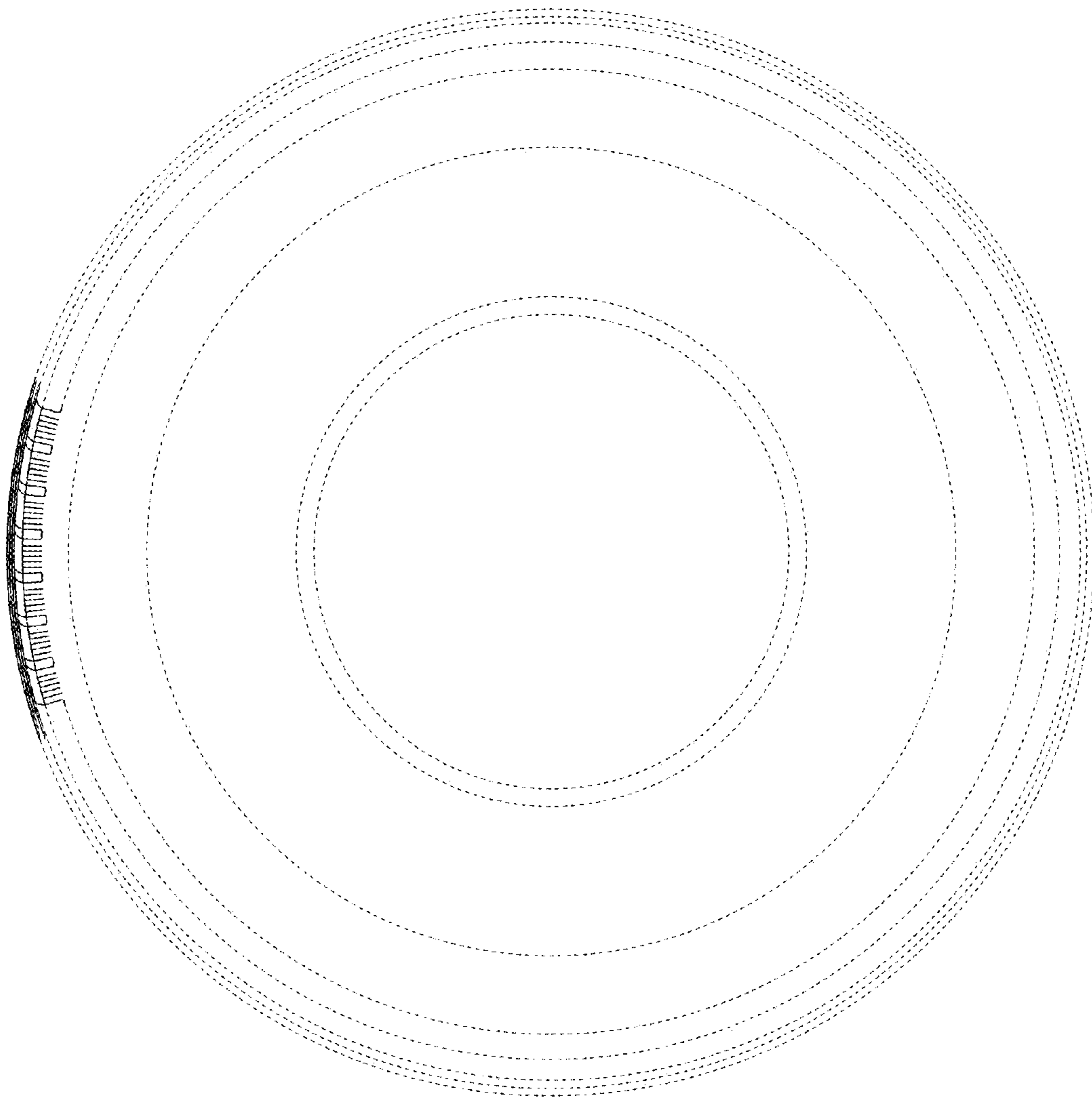

Fig. 6

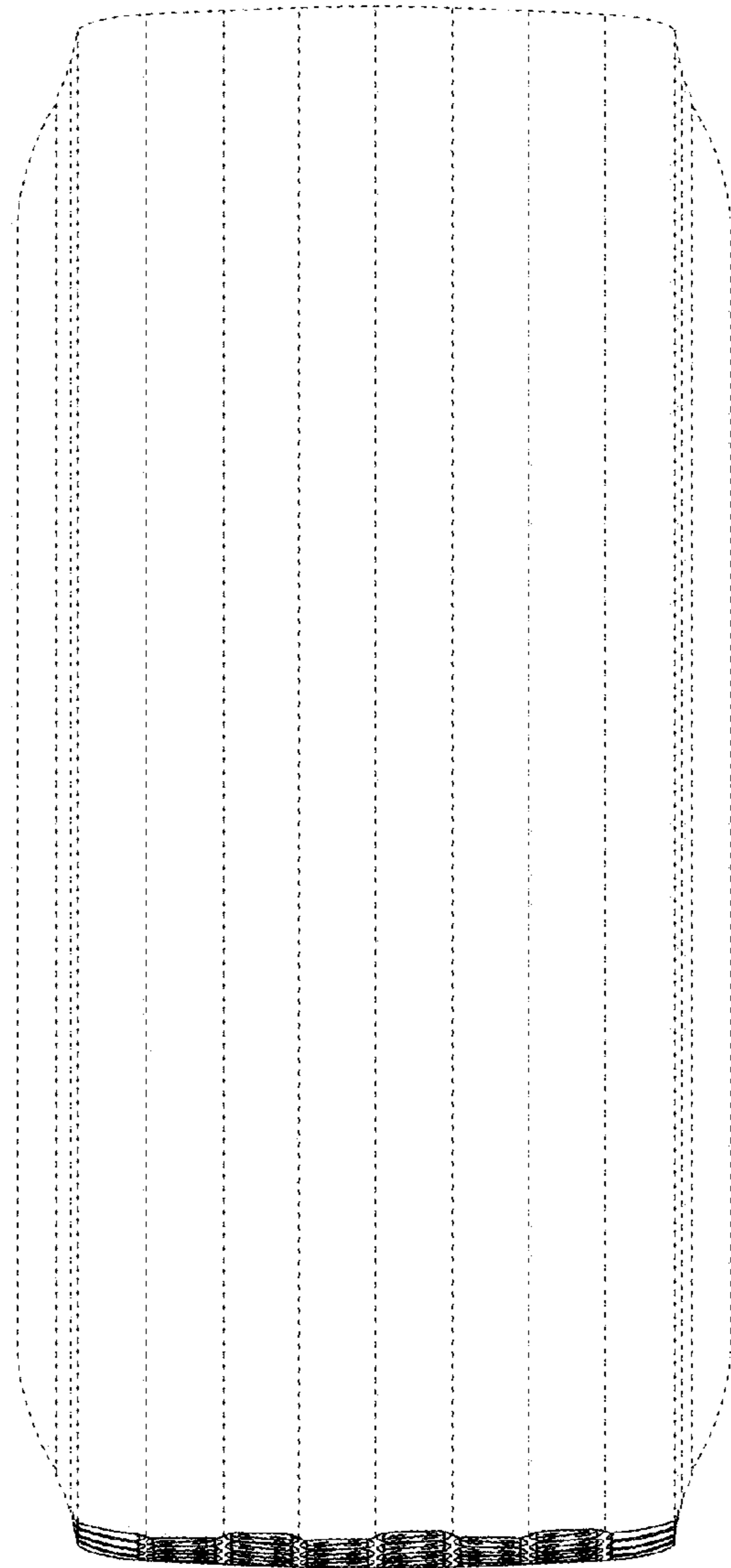

Fig. 7

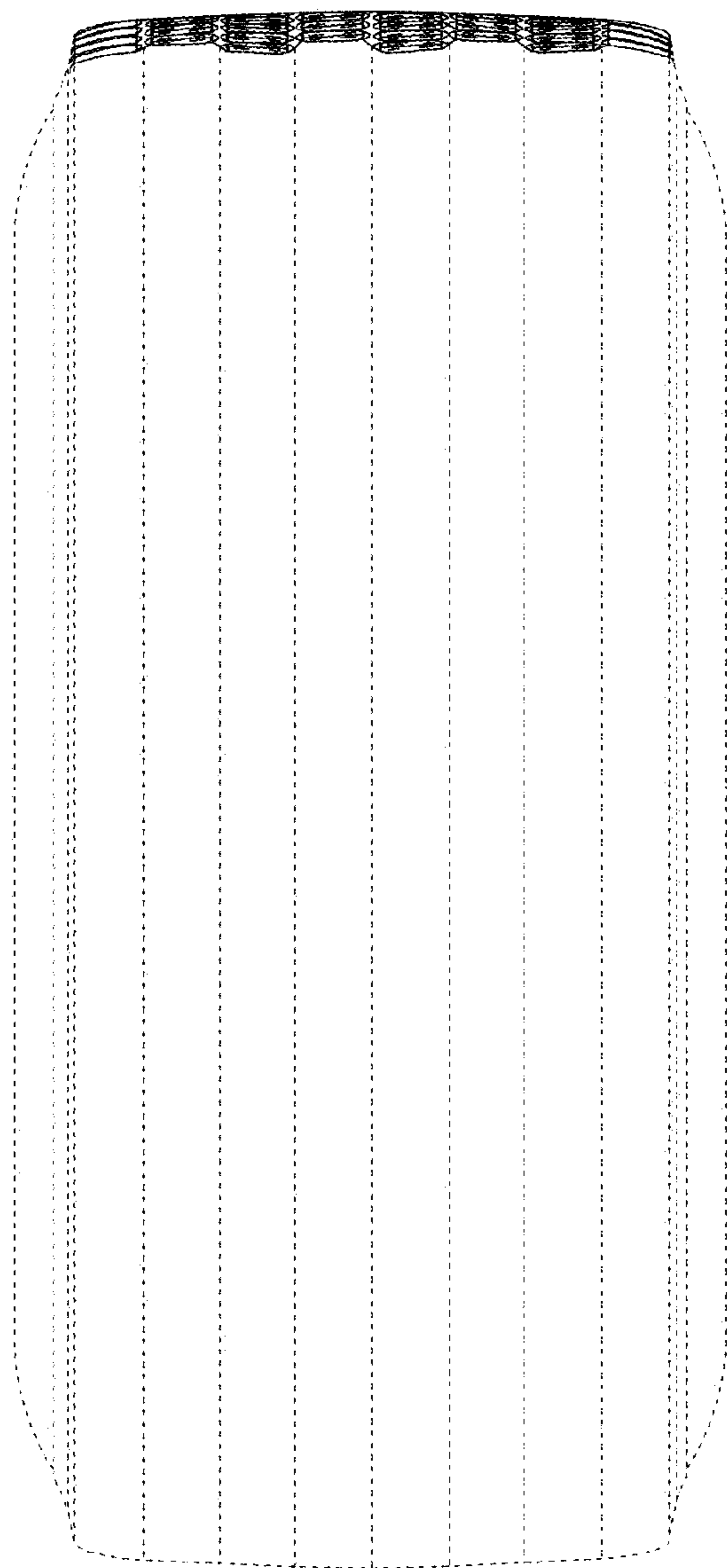

Fig. 8

