



US00D729119S

(12) **United States Design Patent**
Janes

(10) **Patent No.:** **US D729,119 S**

(45) **Date of Patent:** **** May 12, 2015**

(54) **SEAT BELT BUCKLE**

(71) Applicant: **Approved Aeronautics, LLC**, Corona, CA (US)

(72) Inventor: **Dave Janes**, Corona, CA (US)

(73) Assignee: **Approved Aeronautics, LLC**, Corona, CA (US)

(**) Term: **14 Years**

(21) Appl. No.: **29/464,593**

(22) Filed: **Aug. 19, 2013**

(51) **LOC (10) Cl.** **02-07**

(52) **U.S. Cl.**
USPC **D11/216**

(58) **Field of Classification Search**
CPC A44B 99/00; A44B 11/00
USPC D11/1-2, 200-201, 206-210, 214-218;
24/163 R, 169-171, 173, 177-179, 191,
24/194-195, 197, 200, 614-616, 625, 198,
24/578.11, 578.1, 163 K, 114, 455, 573.11,
24/598.2, 69 R; D8/394, 395
See application file for complete search history.

(56) **References Cited**

U.S. PATENT DOCUMENTS

| | | | | |
|-----------|-----|--------|--------|---------|
| 2,826,796 | A * | 3/1958 | Davis | 24/170 |
| 3,165,805 | A * | 1/1965 | Lower | 24/646 |
| D200,772 | S * | 4/1965 | Dahms | D11/216 |
| D327,455 | S * | 6/1992 | Blair | D11/216 |
| 5,123,147 | A * | 6/1992 | Blair | 24/636 |
| D333,640 | S * | 3/1993 | Keller | D11/218 |
| D453,125 | S * | 1/2002 | Citton | D11/216 |

(Continued)

OTHER PUBLICATIONS

http://www.amsafe.com/wp-content/uploads/Lightweight-Seatbelt_US_FINAL.pdf, Amsafe 2012.

<http://www.davisaircraftproducts.com/products/passenger-restraints/aircraft-seat-belts/commercial-passenger-belts.html>, Davis Aircraft Products 2013.

http://www.schroth.com/download/SCHROTH_Aviation_Broschuere.pdf, Schroth 2010.

Primary Examiner — Ralf Seifert

(74) *Attorney, Agent, or Firm* — Jeffrey G. Sheldon; Leech Tishman Fuscaldo & Lampl

(57) **CLAIM**

What is claimed the ornamental design for a seat belt buckle, as shown and described.

DESCRIPTION

FIG. 1 is a perspective view of a seat belt buckle in its closed position according to the present invention, the buckle including a lift cover;

FIG. 2 is a top plan view of the buckle of FIG. 1;

FIG. 3 is a bottom plan view of the buckle of FIG. 1;

FIG. 4 is a side elevation view of the buckle of FIG. 1, where the opposite side elevation view is a mirror image thereof;

FIG. 5 is a front elevation view of the buckle of FIG. 1;

FIG. 6 is a rear elevation view of the buckle of FIG. 1;

FIG. 7 is a perspective view of the lift cover of the buckle of FIG. 1;

FIG. 8 is a side elevation view of the lift cover of the buckle of FIG. 1 wherein the other side elevation view is a mirror image thereof;

FIG. 9 is a front elevation view of the lift cover of the buckle of FIG. 1; and,

FIG. 10 is a bottom plan view of the lift cover of the buckle of FIG. 1.

All portions of the drawings including the belts shown in dashed lines are for illustrative purposes only and form no part of the claimed design.

The broken lines are included for the purpose of illustrating portions of the seat belt buckle that form no part of the claimed design.

1 Claim, 8 Drawing Sheets

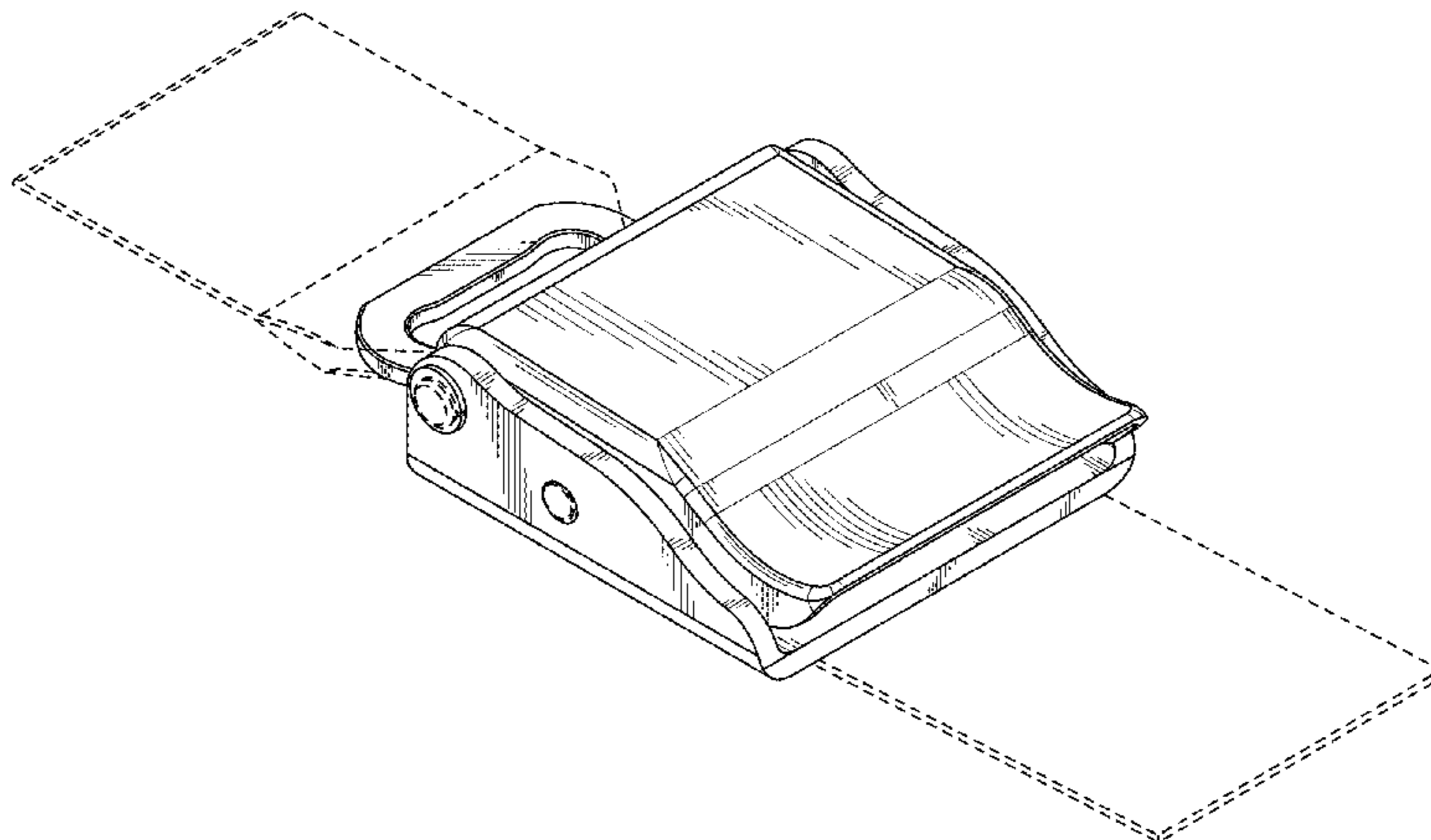

US D729,119 S

Page 2

(56)

References Cited

U.S. PATENT DOCUMENTS

| | | | | |
|----------------|---------|--------------------|---------|---------------------|
| D508,872 S * | 8/2005 | Hoepfner | D11/216 | |
| D559,146 S * | 1/2008 | Kawaguchi | D11/216 | * cited by examiner |
| D600,160 S * | 9/2009 | Kosh et al. | D11/218 | |
| D603,753 S * | 11/2009 | Palmer et al. | D11/216 | |
| 8,561,267 B2 * | 10/2013 | Chang | 24/499 | |

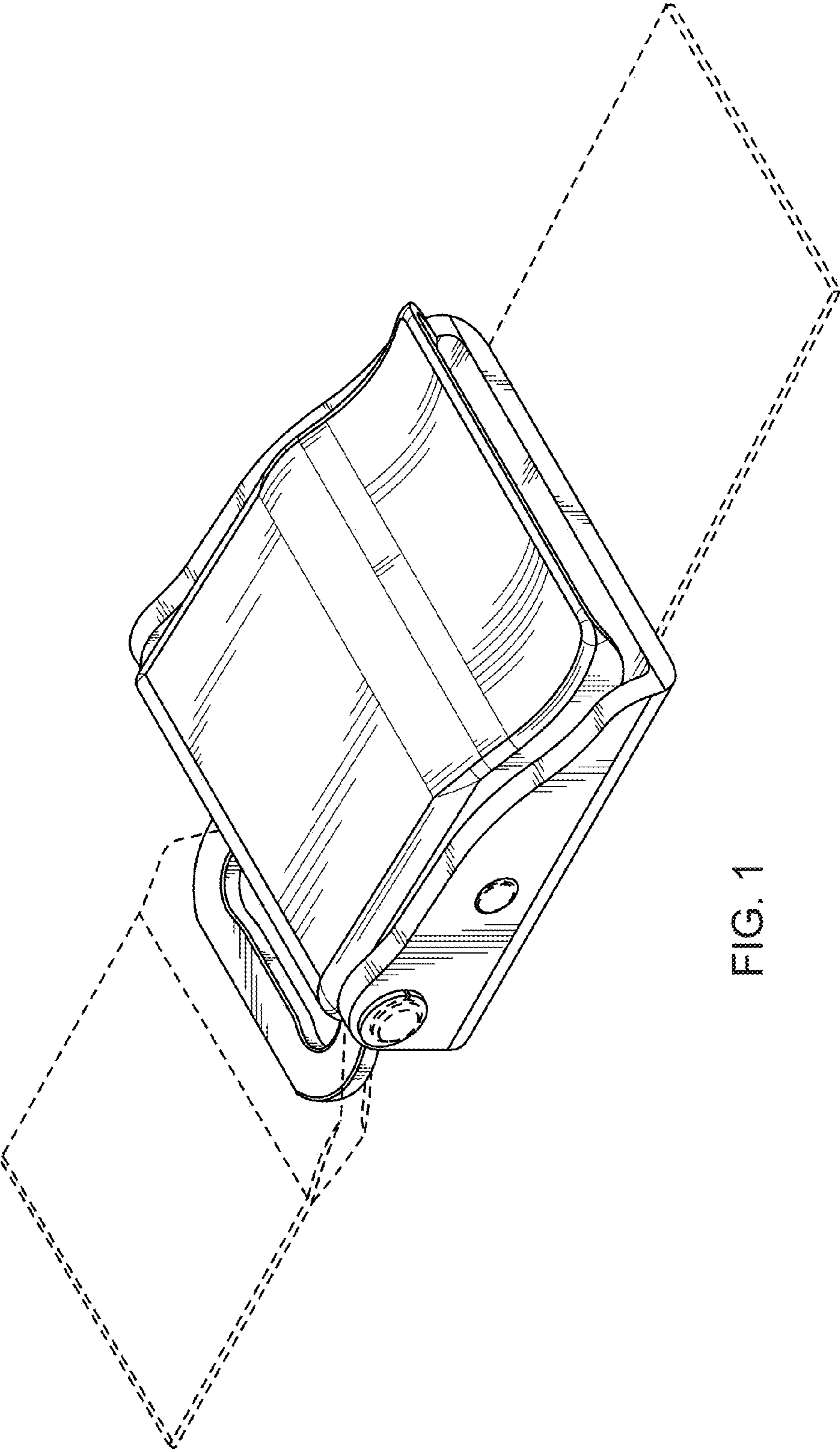

FIG. 1

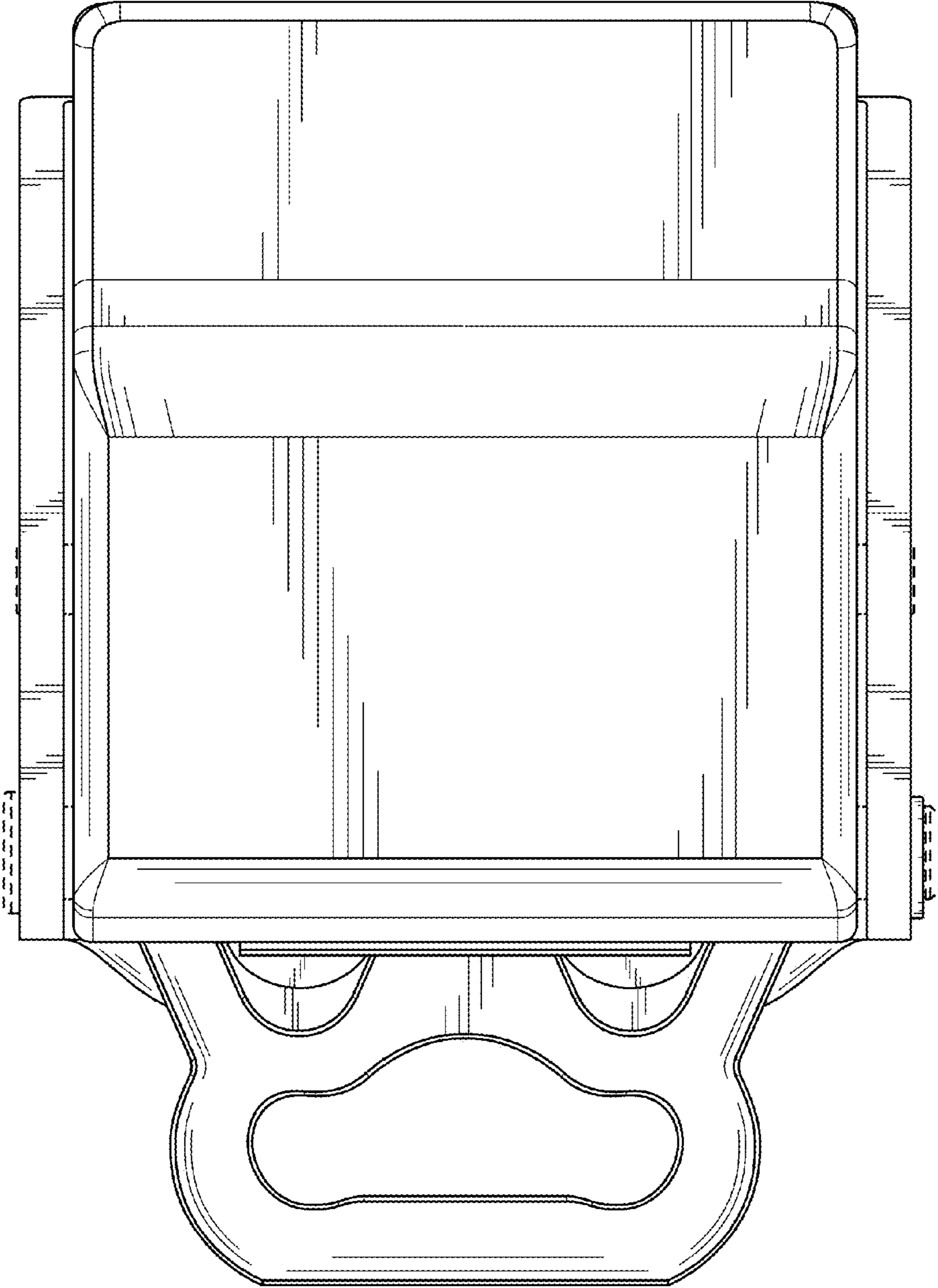

FIG. 2

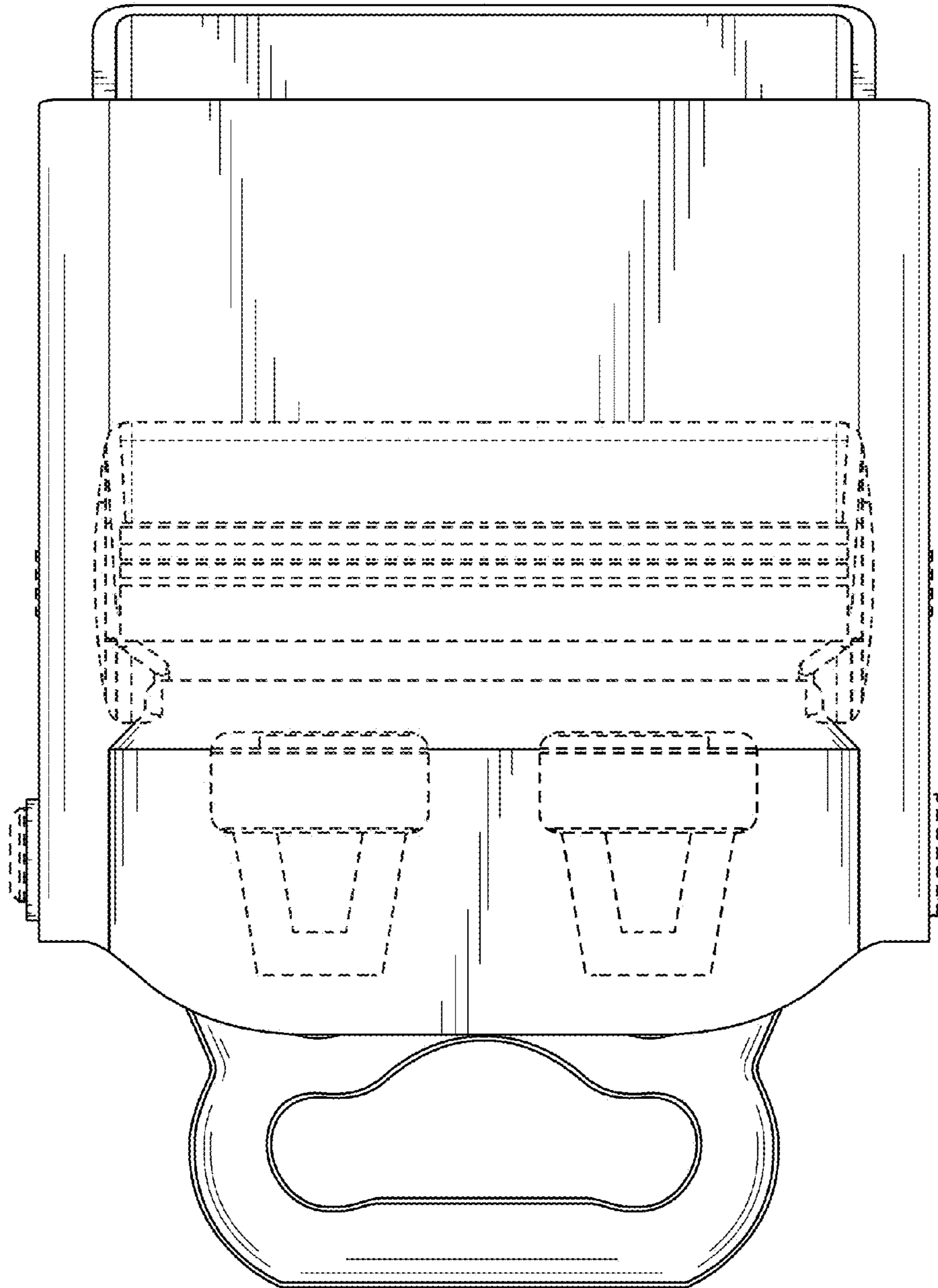

FIG. 3

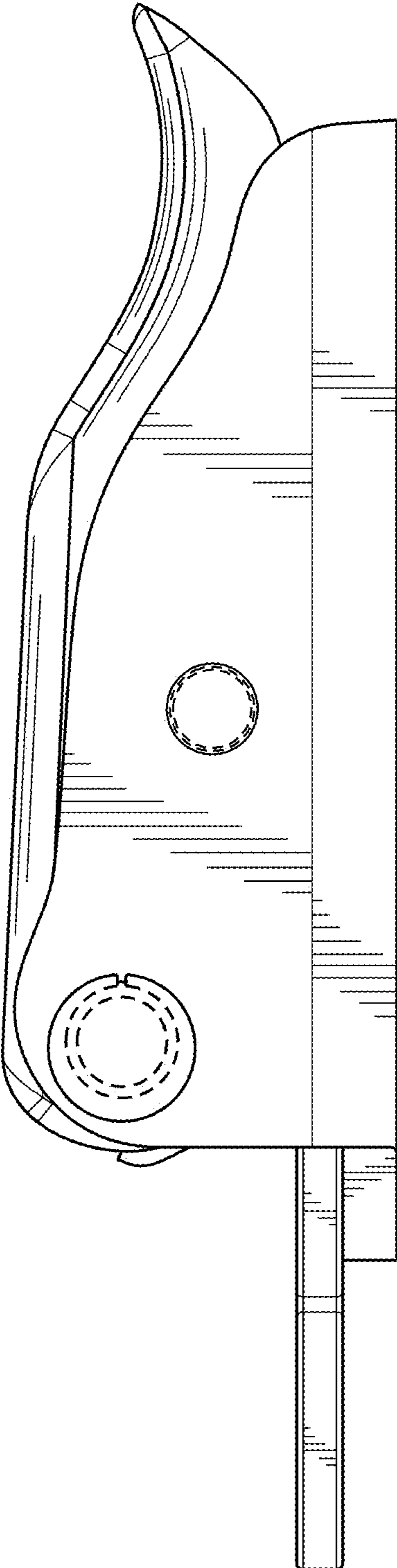

FIG. 4

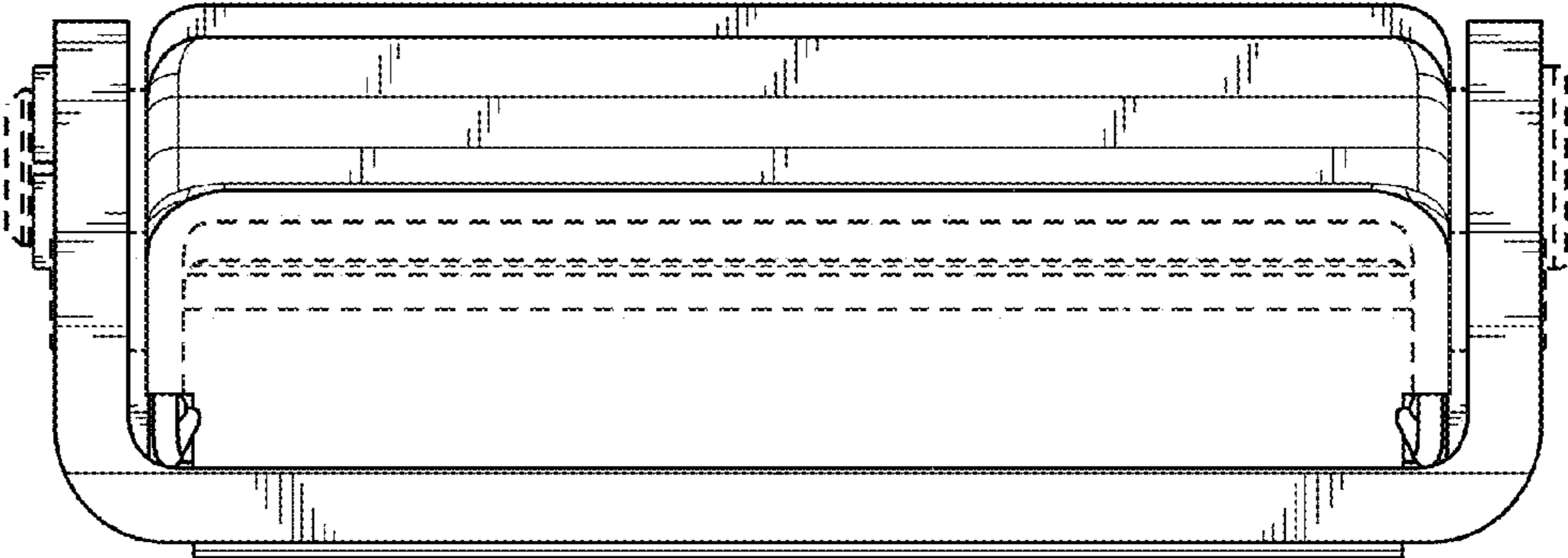

FIG. 5

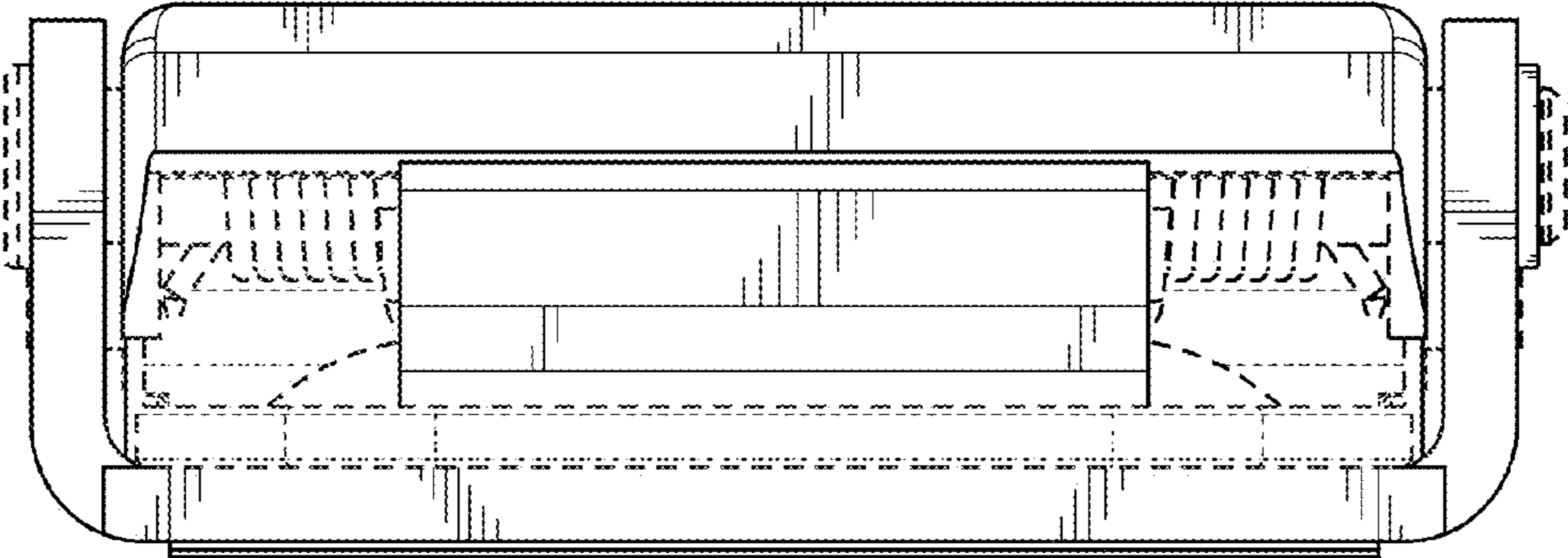

FIG. 6

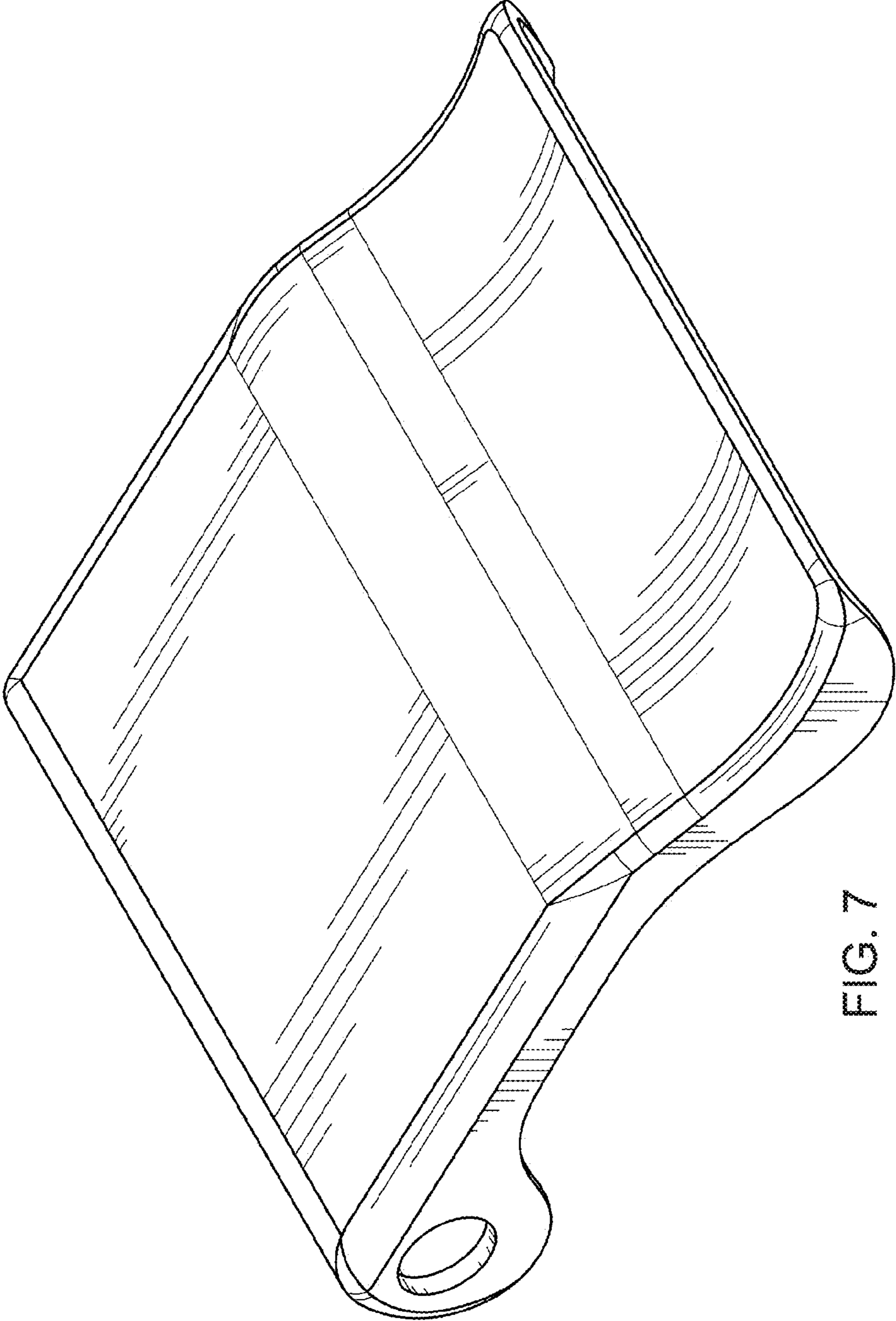

FIG. 7

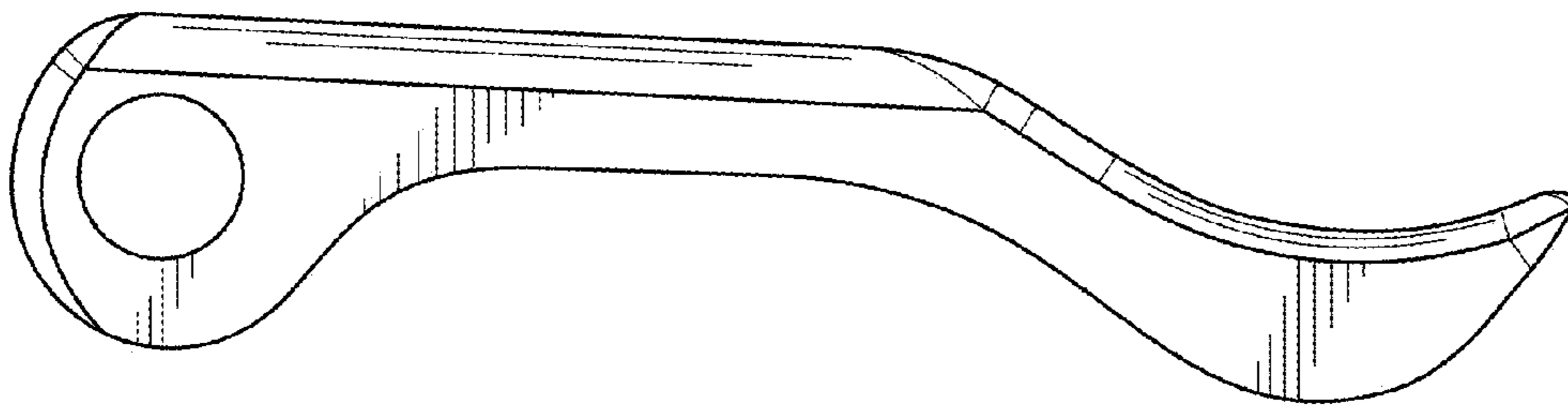

FIG. 8

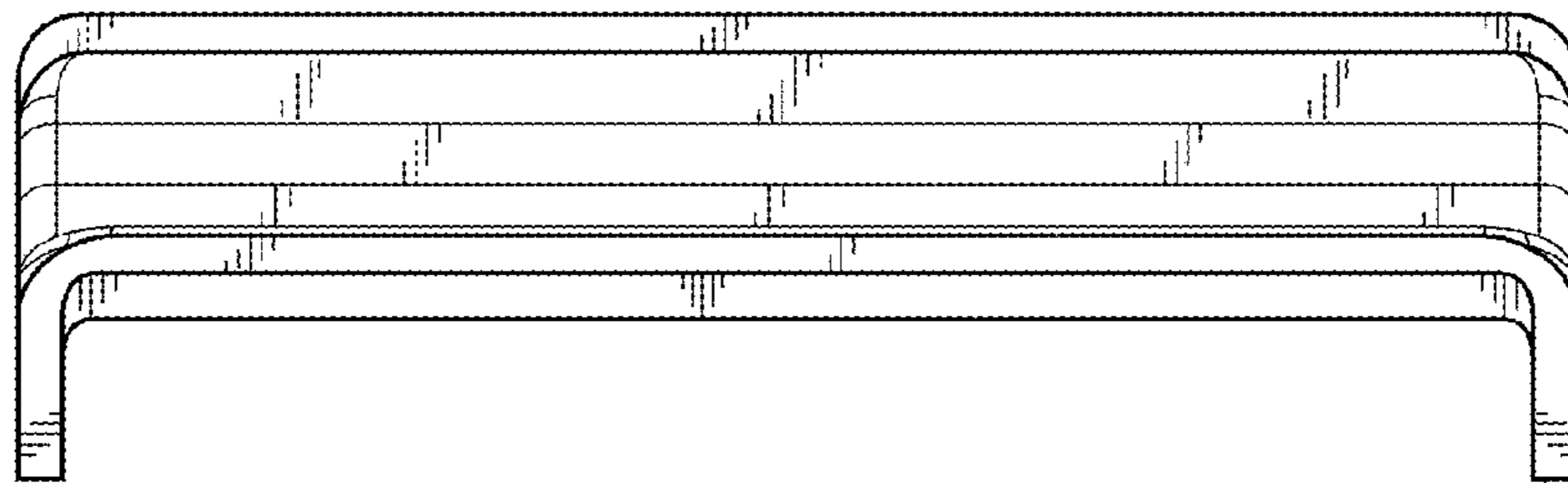

FIG. 9

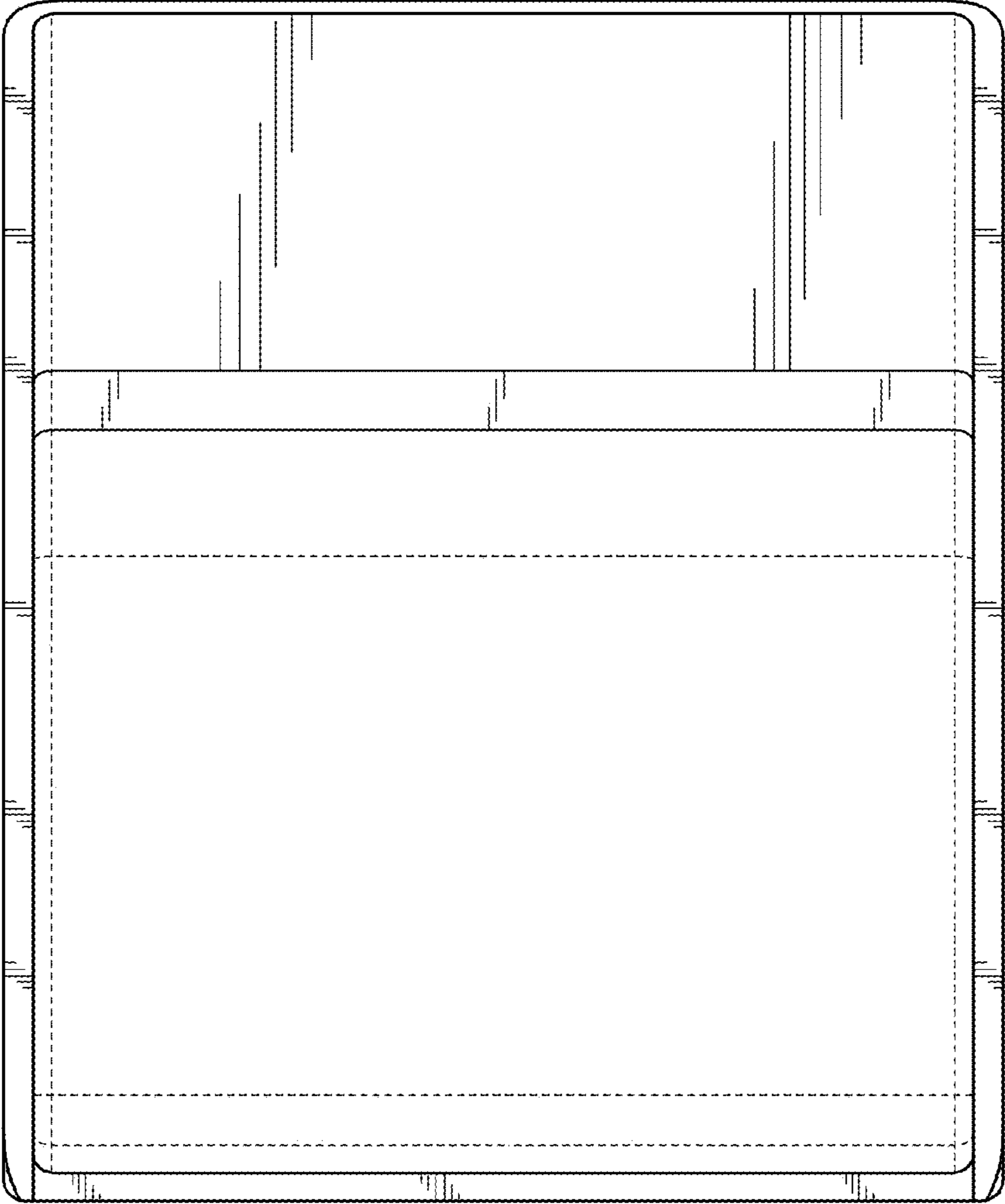

FIG. 10