



US00D728826S

(12) **United States Design Patent**  
**Cyphers et al.**

(10) **Patent No.:** **US D728,826 S**

(45) **Date of Patent:** **\*\* May 5, 2015**

(54) **T-RAIL**

(71) Applicants: **Thomas Jason Cyphers**, Atlanta, GA  
(US); **Cyphers Franklin Reinhardt**,  
Atlanta, GA (US)

(72) Inventors: **Thomas Jason Cyphers**, Atlanta, GA  
(US); **Cyphers Franklin Reinhardt**,  
Atlanta, GA (US)

(\*\*) Term: **14 Years**

(21) Appl. No.: **29/462,266**

(22) Filed: **Aug. 1, 2013**

(51) **LOC (10) Cl.** ..... **25-02**

(52) **U.S. Cl.**

USPC ..... **D25/38.1**

(58) **Field of Classification Search**

USPC ..... D25/38.1, 126; 256/19.21, 22.59,  
256/65.02, 65.04, 65.07, 65.11, 65.15,  
256/65.16

See application file for complete search history.

(56) **References Cited**

U.S. PATENT DOCUMENTS

3,707,276 A \* 12/1972 Francis et al. .... 256/22  
D548,363 S \* 8/2007 Hein ..... D25/38.1  
D661,813 S \* 6/2012 Walker ..... D25/38.1  
2008/0135823 A1 \* 6/2008 Amendola ..... 256/59

\* cited by examiner

*Primary Examiner* — Doris Clark

(74) *Attorney, Agent, or Firm* — James M. Smedley LLC;  
James Michael Smedley, Esq.

(57) **CLAIM**

We claim the ornamental design for a T-rail, as shown and described.

**DESCRIPTION**

FIG. 1 is a top perspective view showing the new design.  
FIG. 2 is a bottom perspective view showing the new design.  
FIG. 3 is a top view showing the new design.  
FIG. 4 is a bottom view showing the new design.  
FIG. 5 is a side view showing the new design, with the opposite side being a mirror image thereof; and,  
FIG. 6 is a front view showing the new design, with the rear view being a mirror image thereof.  
The shading lines shown in the drawings represent the approximate three-dimensional contour of the design, and are not intended to indicate surface decoration.

**1 Claim, 3 Drawing Sheets**

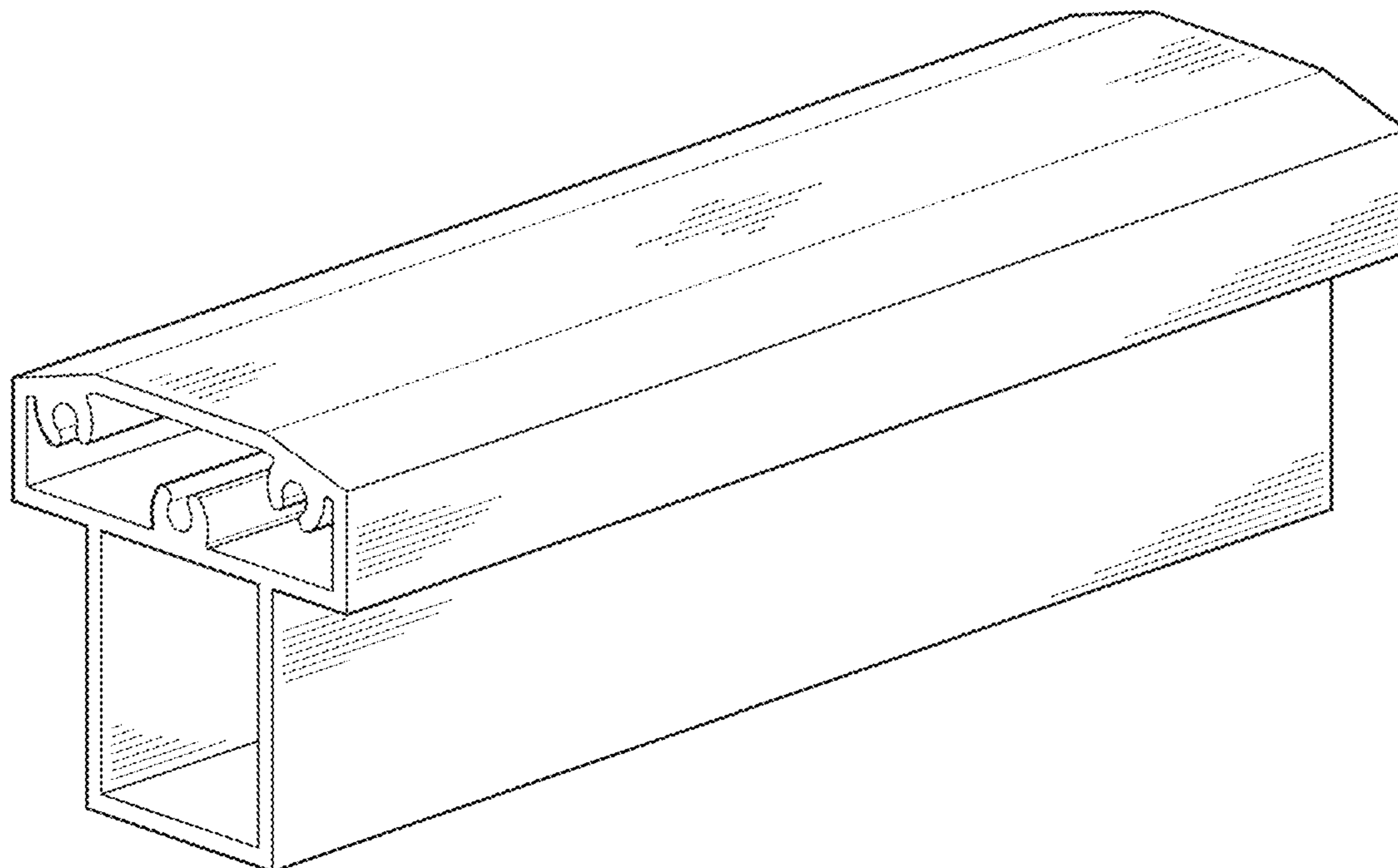

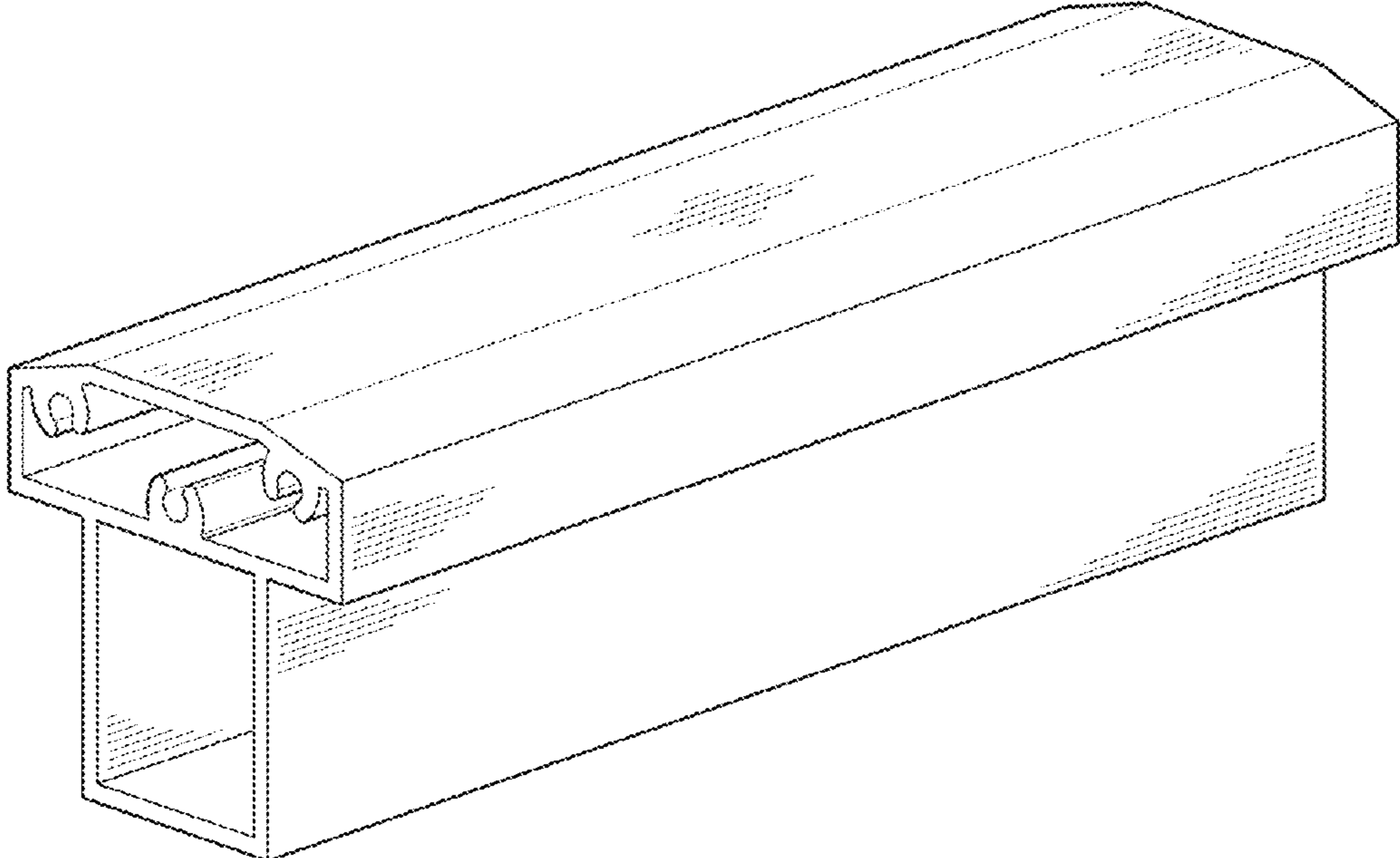

FIG. 1

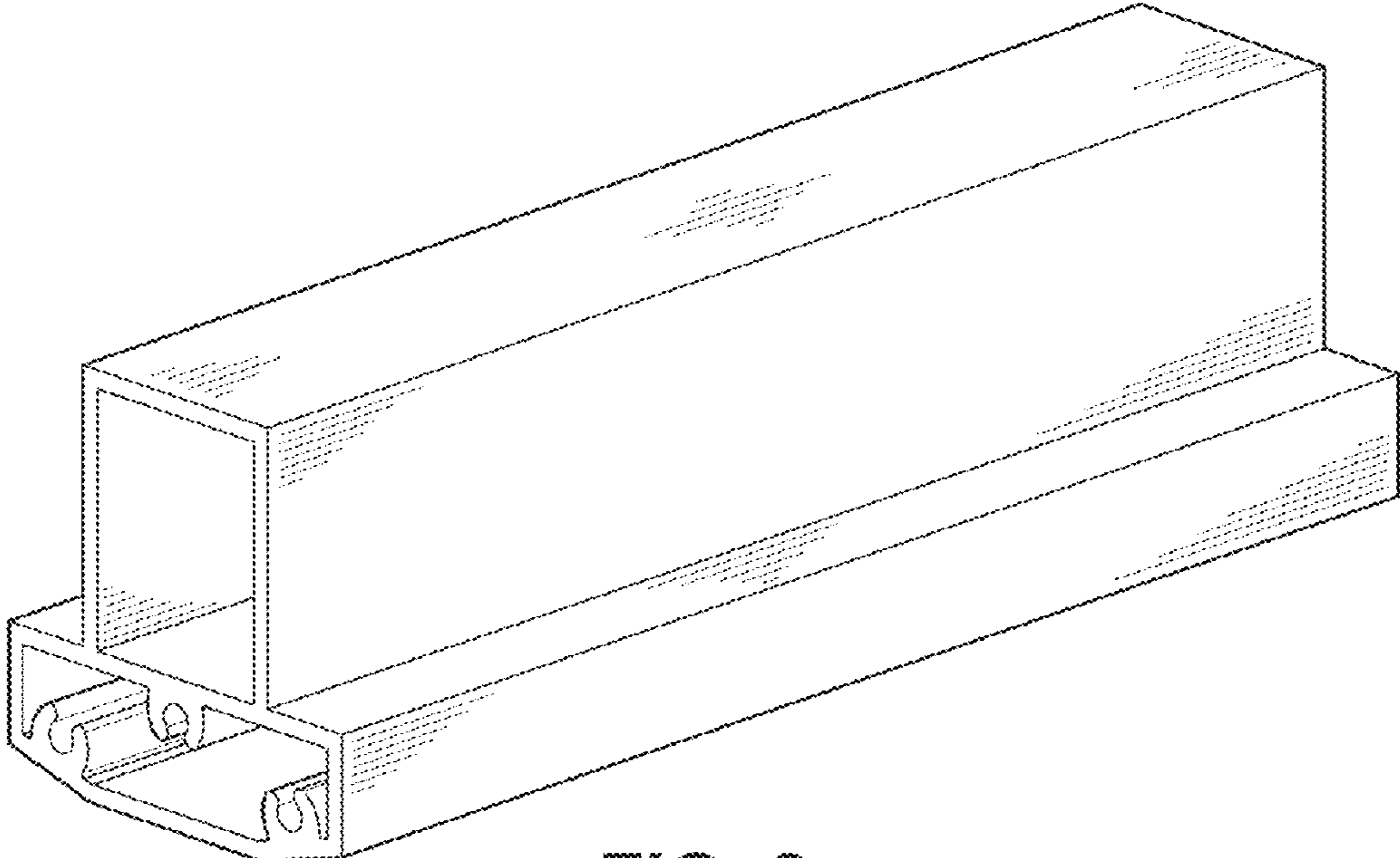

FIG. 2



FIG. 3

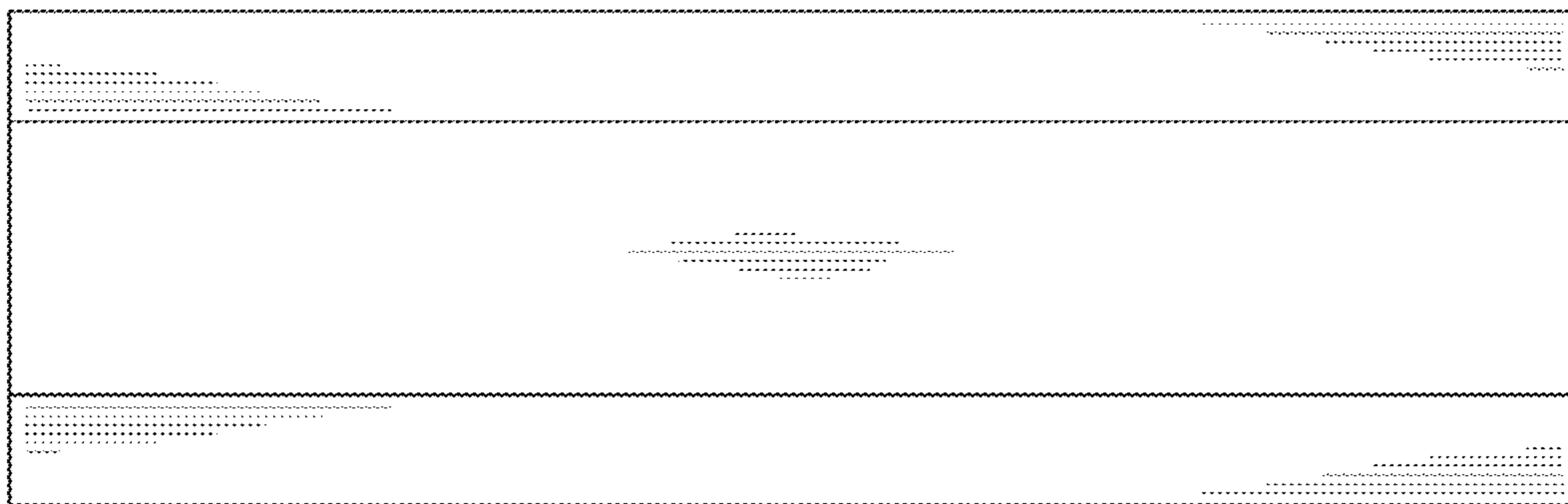

FIG. 4

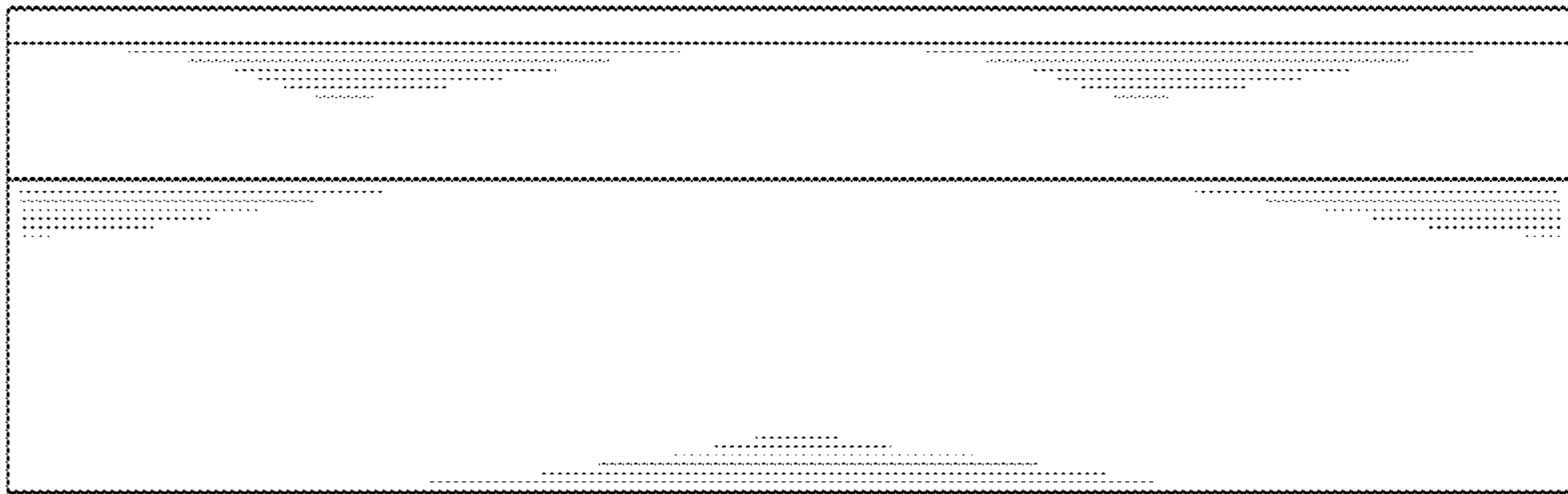

FIG. 5

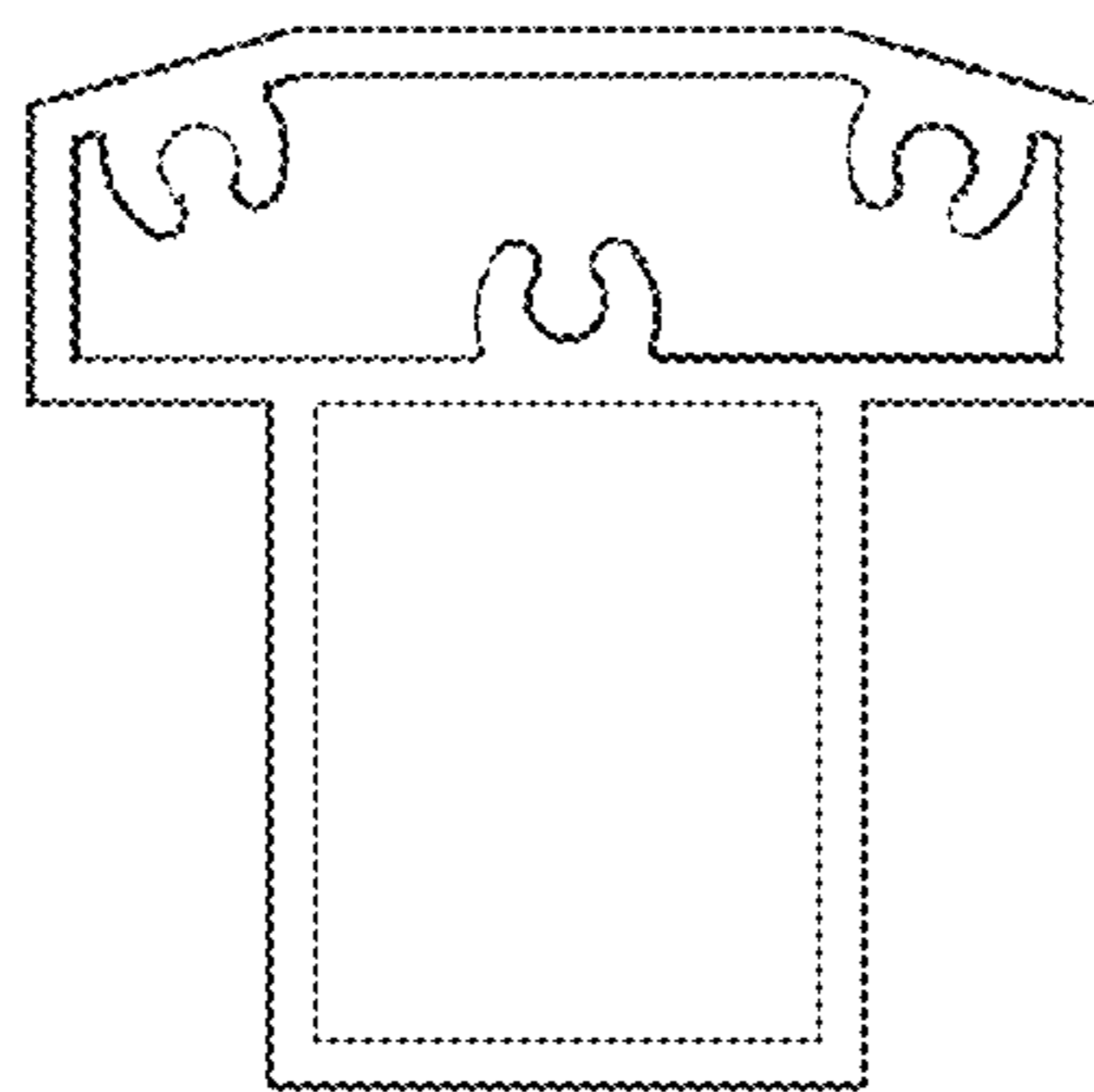

FIG. 6