



US00D728822S

(12) **United States Design Patent**
Ryan et al.

(10) **Patent No.:** **US D728,822 S**

(45) **Date of Patent:** **** May 5, 2015**

(54) **BUILDING**

(71) Applicant: **Purepodz Limited**, Akaroa (NZ)

(72) Inventors: **Grant James Ryan**, Akaroa (NZ); **Peter Lloyd Higgins**, Christchurch (NZ)

(73) Assignee: **Purepodz Limited**, Akaroa (NZ)

(**) Term: **14 Years**

(21) Appl. No.: **29/492,876**

(22) Filed: **Jun. 3, 2014**

(30) **Foreign Application Priority Data**

Dec. 3, 2013 (NZ) 418296

(51) **LOC (10) Cl.** **25-03**

(52) **U.S. Cl.**
USPC **D25/15**

(58) **Field of Classification Search**
USPC D25/1-35; 135/117, 121, 143; 52/63,
52/71, 73
See application file for complete search history.

(56) **References Cited**

U.S. PATENT DOCUMENTS

2,745,420 A * 5/1956 Zitomer 52/63
2,780,843 A * 2/1957 De Sherbinin 52/69

4,188,764 A * 2/1980 Gode 52/481.2
4,571,899 A * 2/1986 Minter 52/60
4,583,333 A * 4/1986 Minter 52/91.1
4,686,805 A * 8/1987 Forslin 52/208
4,726,153 A * 2/1988 Adler et al. 52/63
4,884,376 A * 12/1989 DeBlock et al. 52/92.2
4,918,882 A * 4/1990 Funk 52/86
5,134,813 A * 8/1992 Betts 52/92.3
D335,002 S * 4/1993 Read et al. D30/108

* cited by examiner

Primary Examiner — Garth Rademaker

Assistant Examiner — Samantha Q Lawrence

(74) *Attorney, Agent, or Firm* — Stephen M. De Klerk

(57) **CLAIM**

The design for a building, as shown and described.

DESCRIPTION

FIG. 1 is a perspective view of a building showing our new design;

FIG. 2 is a second perspective view thereof;

FIG. 3 is a third perspective view thereof;

FIG. 4 is a fourth perspective view thereof;

FIG. 5 is a bottom view thereof; and,

FIG. 6 is a top view thereof.

The broken lines shown in FIGS. 1-6 illustrate portions of the building that form no part of the claimed design.

1 Claim, 6 Drawing Sheets

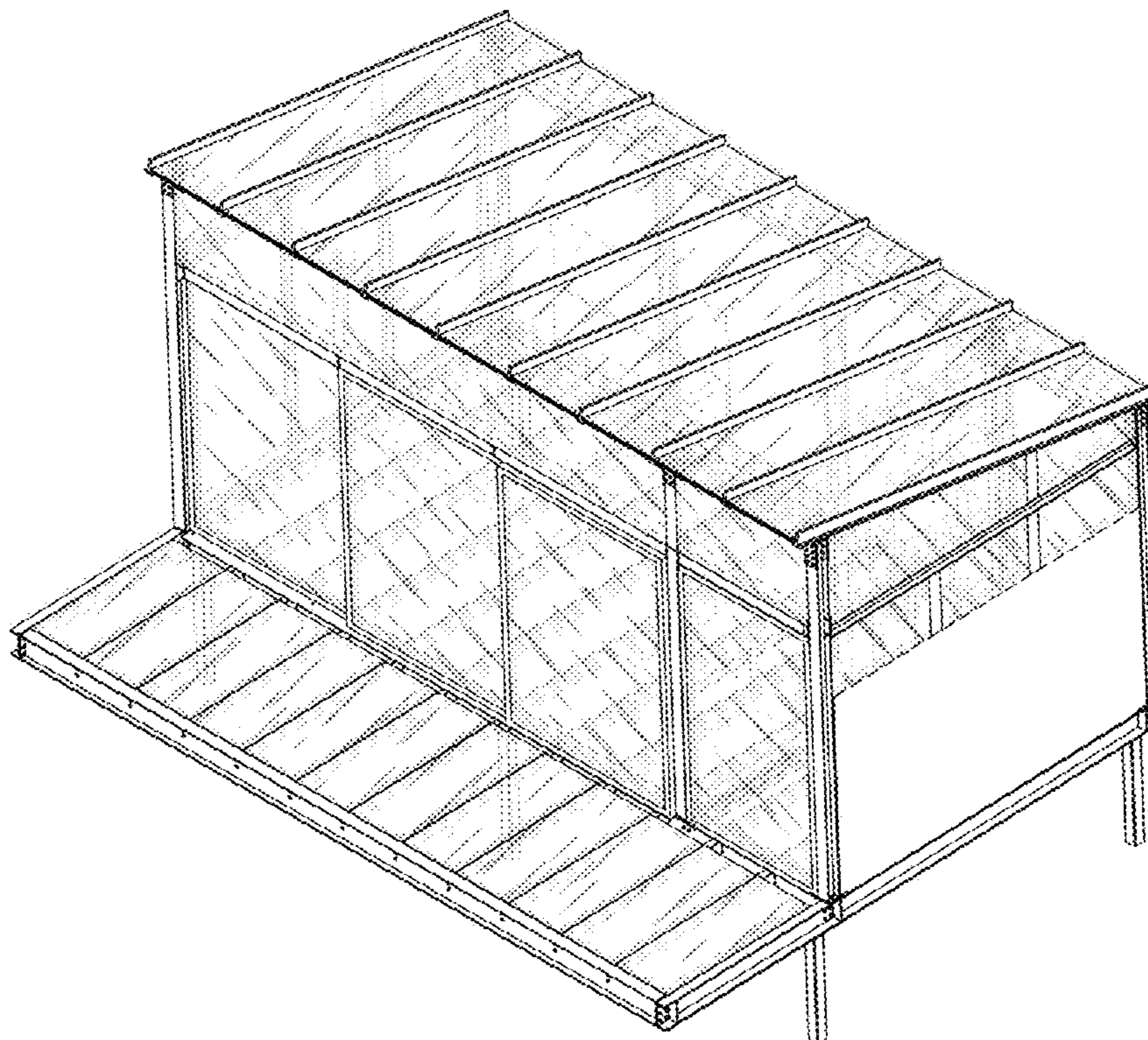

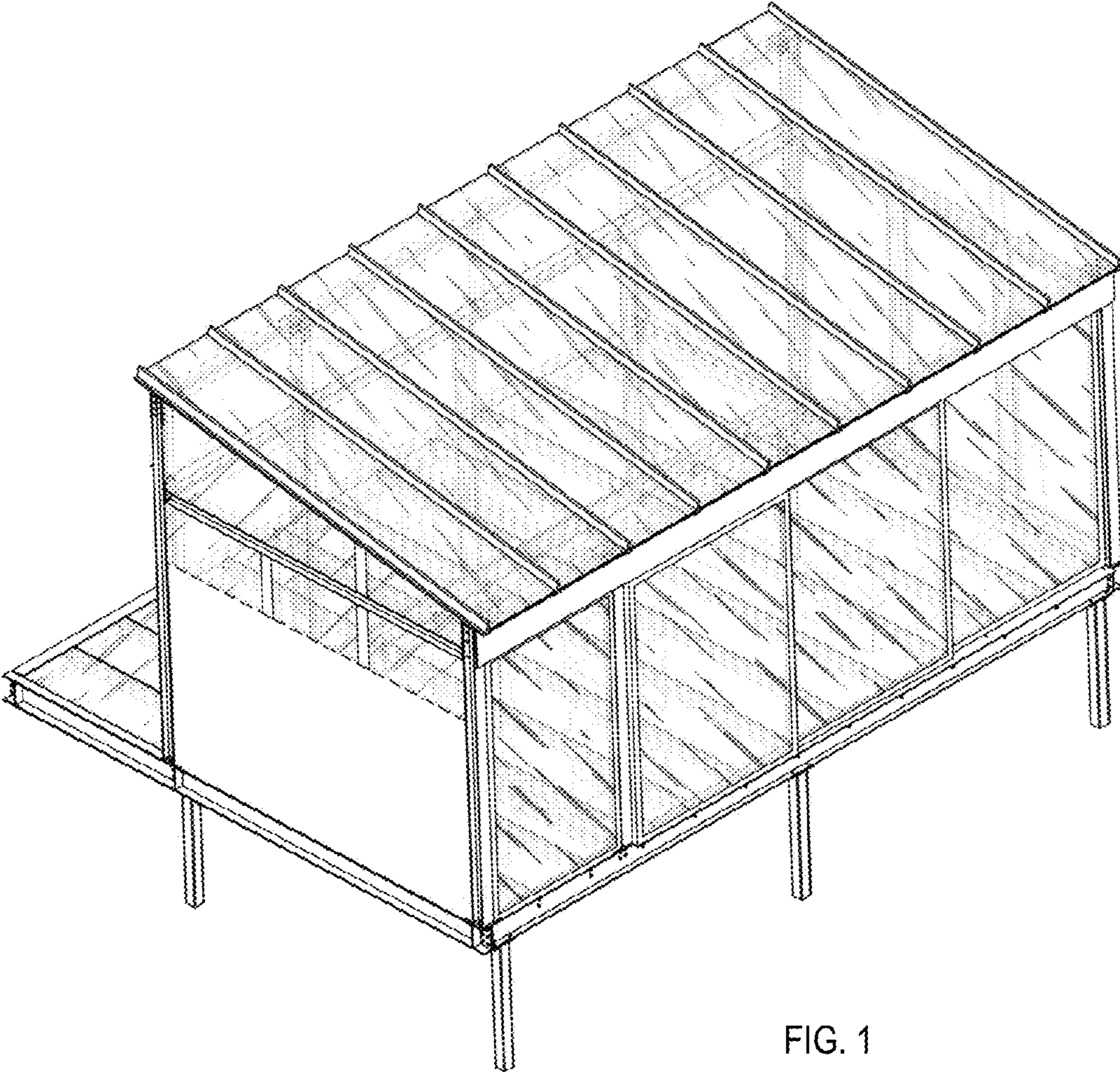

FIG. 1

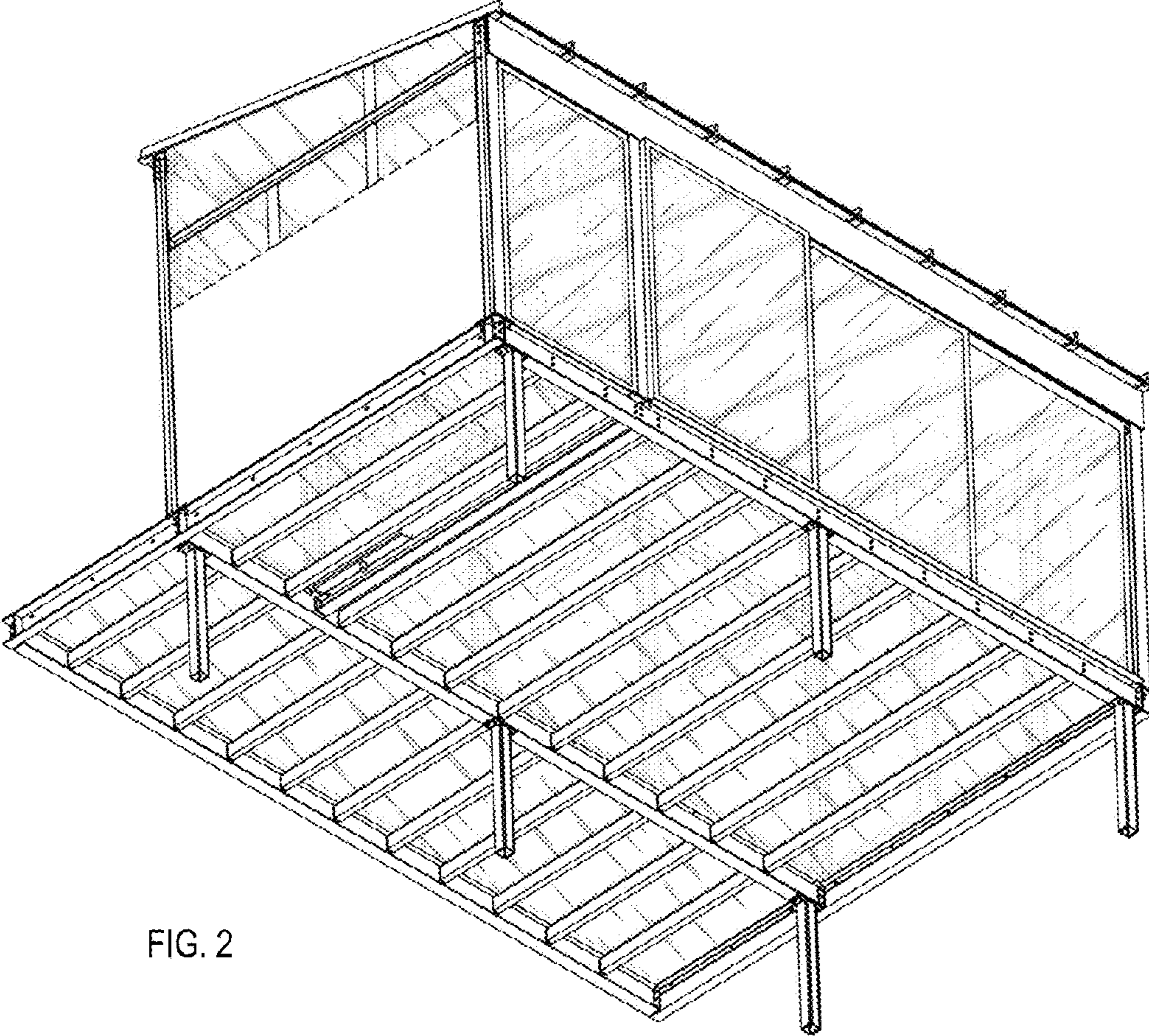

FIG. 2

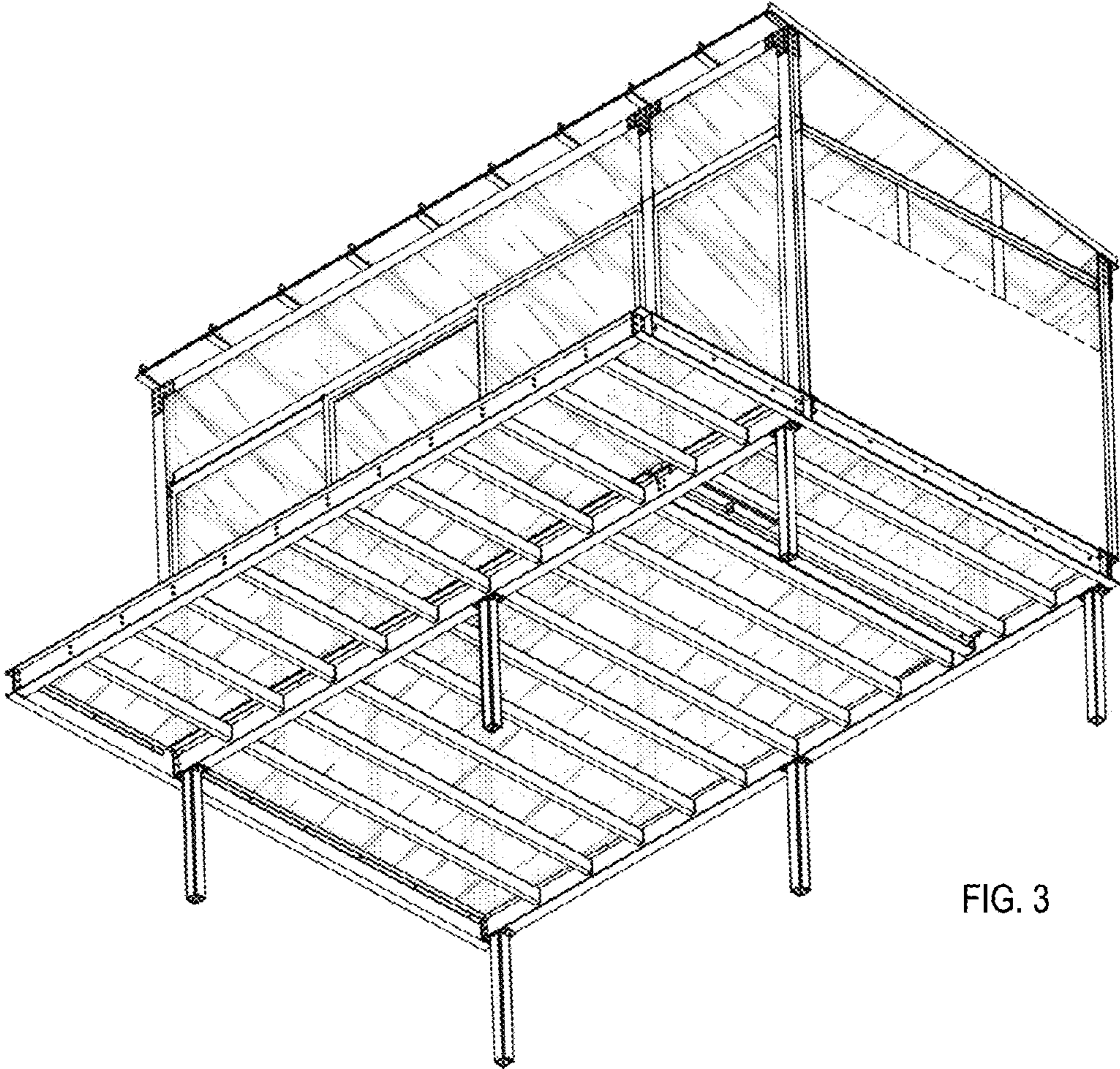

FIG. 3

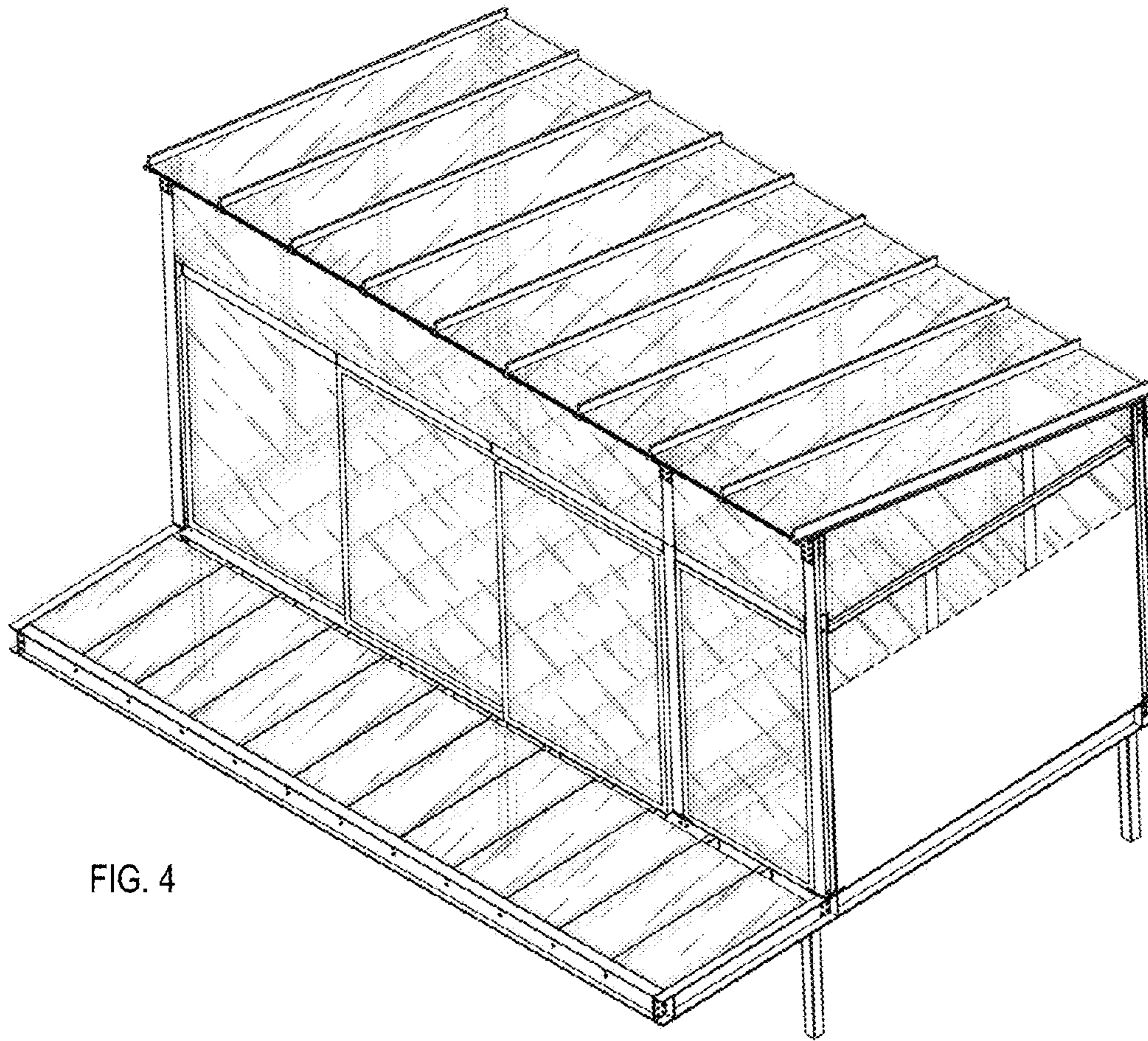

FIG. 4

FIG. 5

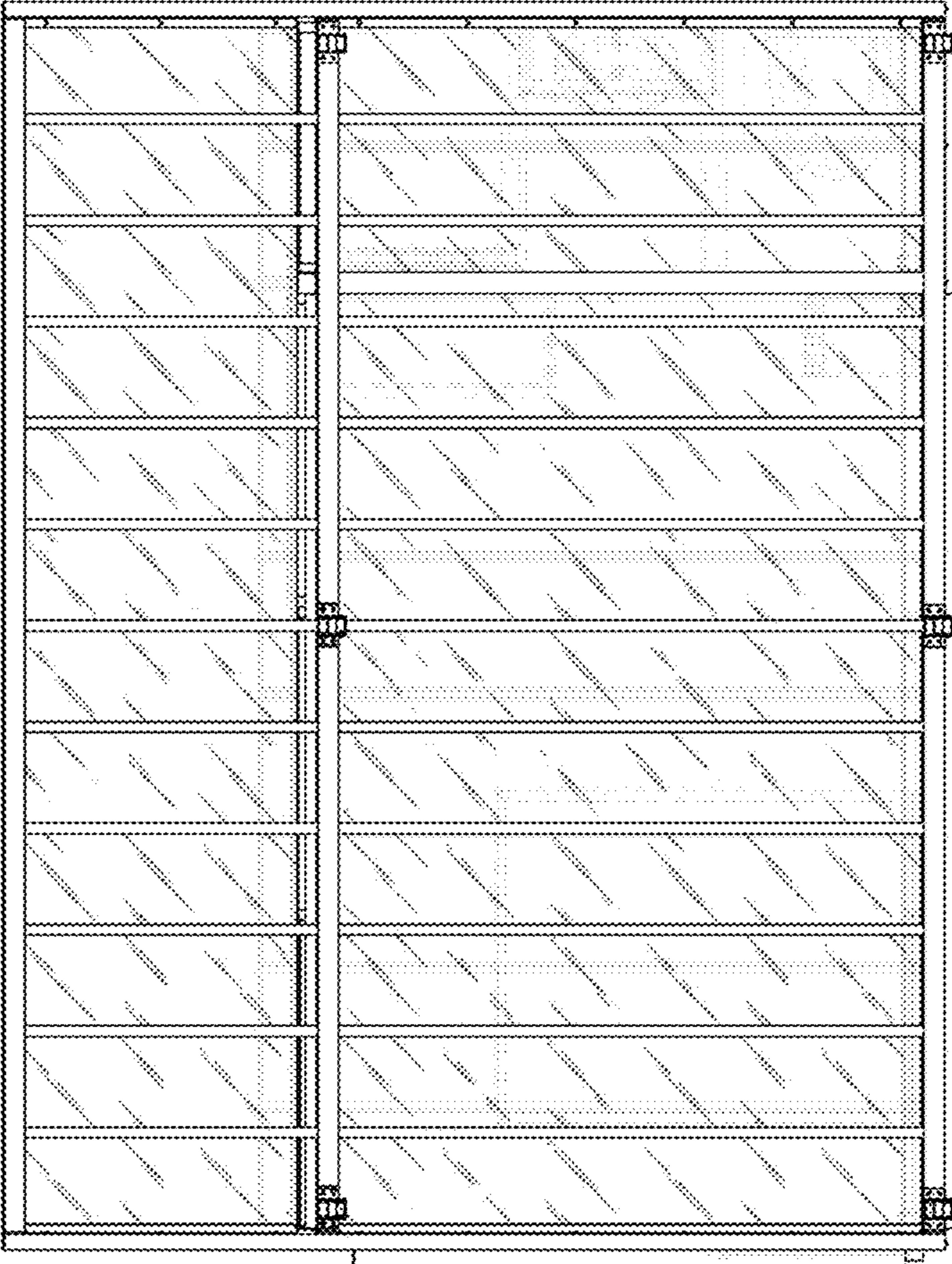

FIG. 6

