



US00D728769S

(12) **United States Design Patent**  
**Dyson et al.**

(10) **Patent No.:** **US D728,769 S**  
(45) **Date of Patent:** **\*\* May 5, 2015**

(54) **FAN**  
(71) Applicant: **Dyson Technology Limited**, Wiltshire (GB)  
(72) Inventors: **James Dyson**, Bristol (GB); **David Dos Reis**, Bristol (GB); **Adam James Bates**, Oxford (GB); **Arran George Smith**, Bristol (GB); **Thomas Richard Mogridge**, Bristol (GB); **Roy Edward Poulton**, Swindon (GB); **Joseph Eric Hodgetts**, Bristol (GB); **David Robert Sunderland**, Bristol (GB)

1,357,261 A 11/1920 Svoboda  
(Continued)

FOREIGN PATENT DOCUMENTS

BE 560119 8/1957  
CA 1055344 5/1979

(Continued)

OTHER PUBLICATIONS

Pisenic Bladeless Fan (16 Inches with Remote Control, Bladeless Fan Air Conditioner 110v, Air Multiplier Table Fans, Green). Amazon.com [online PDF] 4 pages. Posted May 11, 2013[retrieved on Sep. 2, 2014]. Retrieved from Internet: <[http://www.amazon.com/Pisenic-Bladeless-Control-Conditioner-Multiplier/dp/B007VCI78M/ref=pd\\_rhf\\_se\\_p\\_imgnr\\_3/](http://www.amazon.com/Pisenic-Bladeless-Control-Conditioner-Multiplier/dp/B007VCI78M/ref=pd_rhf_se_p_imgnr_3/)>.\*

(Continued)

(73) Assignee: **Dyson Technology Limited**, Malmesbury, Wiltshire (GB)

(\*\*) Term: **14 Years**

(21) Appl. No.: **29/480,896**

(22) Filed: **Jan. 30, 2014**

(30) **Foreign Application Priority Data**

Aug. 1, 2013 (EM) ..... 001379531-0001  
(51) **LOC (10) Cl.** ..... **23-04**

(52) **U.S. Cl.**  
USPC ..... **D23/370; D23/378; D23/342**

(58) **Field of Classification Search**  
USPC ..... D23/336, 342, 370-379, 411, 499; D6/309; 415/90, 110, 119, 126, 148, 415/182.1, 183, 207, 208.1, 208.2, 211.2, 415/230; 416/100, 244 R, 246, 247 R; 261/28, 31, 116; 417/84, 177, 198, 417/313, 423.1, 234; 137/338; 392/361, 392/365, 367

See application file for complete search history.

(56) **References Cited**

U.S. PATENT DOCUMENTS

284,962 A 9/1883 Huston

*Primary Examiner* — Susan Bennett Hattan  
*Assistant Examiner* — Marie Fast Horse  
(74) *Attorney, Agent, or Firm* — Morrison & Foerster LLP

(57) **CLAIM**

We claim the ornamental design for a fan, as shown and described.

**DESCRIPTION**

FIG. 1 is a perspective view of a fan showing our new design; FIG. 2 is a front view thereof; FIG. 3 is a rear view thereof; FIG. 4 is a side view thereof; FIG. 5 is a side view of the opposite side of FIG. 4; FIG. 6 is a top view thereof; and, FIG. 7 is a bottom view thereof.

The broken lines in the drawings consisting of even dashes depict portions of the fan that form no part of the claimed design. The broken lines consisting of uneven dashes depict the bounds of the claim.

**1 Claim, 6 Drawing Sheets**

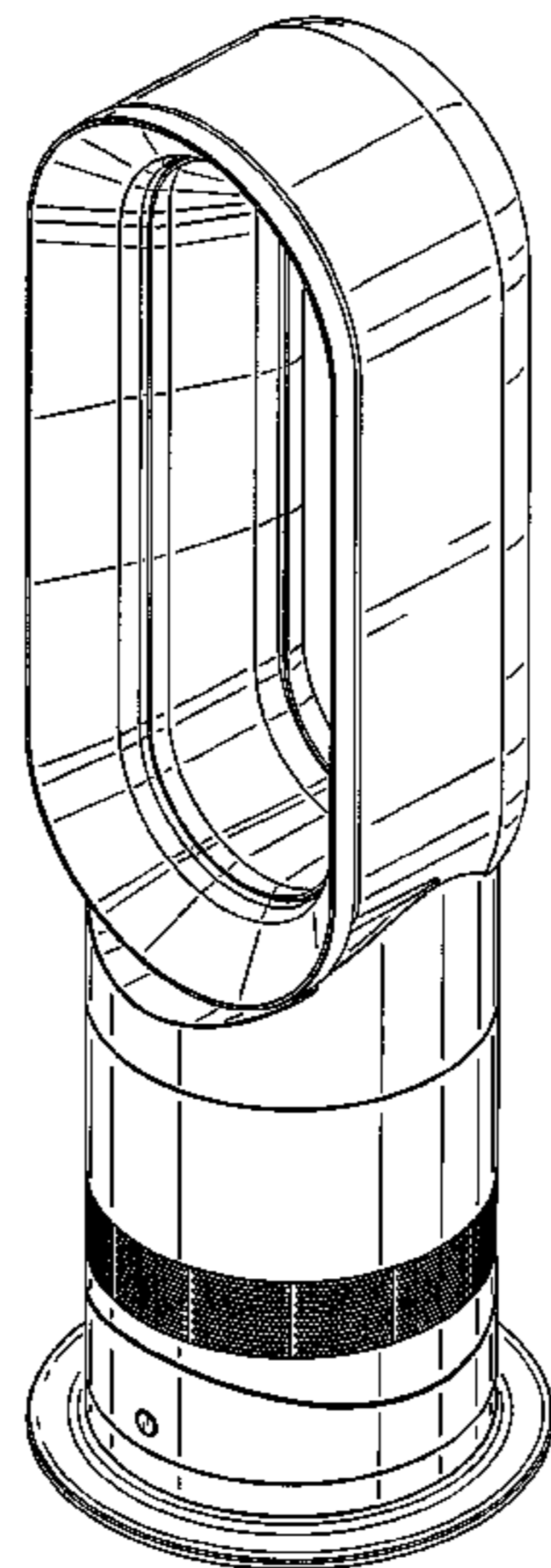

(56)

## References Cited

## U.S. PATENT DOCUMENTS

1,767,060 A	6/1930	Ferguson	5,110,266 A	5/1992	Toyoshima et al.
1,896,869 A	2/1933	Larsh	5,168,722 A	12/1992	Brock
2,014,185 A	9/1935	Martin	5,176,856 A	1/1993	Takahashi et al.
2,035,733 A	3/1936	Wall	5,188,508 A	2/1993	Scott et al.
2,071,266 A	2/1937	Schmidt	D343,231 S *	1/1994	Lim ..... D23/336
D103,476 S	3/1937	Weber	5,296,769 A	3/1994	Havens et al.
2,115,883 A	5/1938	Sher	D346,017 S *	4/1994	Lim ..... D23/336
D115,344 S	6/1939	Chapman	5,310,313 A	5/1994	Chen
2,210,458 A	8/1940	Keilholtz	5,317,815 A	6/1994	Hwang
2,258,961 A	10/1941	Saathoff	5,338,495 A	8/1994	Steiner et al.
2,295,502 A	9/1942	Lamb	5,402,938 A	4/1995	Sweeney
2,336,295 A	12/1943	Reimuller	5,407,324 A	4/1995	Starnes, Jr. et al.
2,363,839 A	11/1944	Demuth	5,425,902 A	6/1995	Miller et al.
2,433,795 A	12/1947	Stokes	5,435,489 A	7/1995	Jenkins et al.
2,473,325 A	6/1949	Aufiero	5,483,616 A	1/1996	Chiu et al.
2,476,002 A	7/1949	Stalker	5,518,370 A	5/1996	Wang et al.
2,488,467 A	11/1949	De Lisio	D374,712 S *	10/1996	Jane et al. .... D23/336
2,510,132 A	6/1950	Morrison	5,609,473 A	3/1997	Litvin
2,544,379 A	3/1951	Davenport	5,645,769 A	7/1997	Tamaru et al.
2,547,448 A	4/1951	Demuth	5,649,370 A	7/1997	Russo
2,583,374 A	1/1952	Hoffman	D382,951 S *	8/1997	Deines et al. .... D23/336
2,620,127 A	12/1952	Radcliffe	5,671,321 A	9/1997	Bagnuolo
2,711,682 A	6/1955	Drechsel	5,677,982 A	10/1997	Levine et al.
2,765,977 A	10/1956	Morrison	5,735,683 A	4/1998	Muschelknautz
2,808,198 A	10/1957	Morrison	5,762,034 A	6/1998	Foss
2,813,673 A	11/1957	Smith	5,762,661 A	6/1998	Kleinberger et al.
2,830,779 A	4/1958	Wentling	5,783,117 A	7/1998	Byassee et al.
2,838,229 A	6/1958	Belanger	5,794,306 A	8/1998	Firdaus
2,922,277 A	1/1960	Bertin	D398,983 S	9/1998	Keller et al.
2,922,570 A	1/1960	Allen	5,841,080 A	11/1998	Lida et al.
3,004,403 A	10/1961	Laporte	5,843,344 A	12/1998	Junket et al.
3,047,208 A	7/1962	Coanda	5,859,952 A	1/1999	Levine et al.
3,270,655 A	9/1966	Guirl et al.	5,862,037 A	1/1999	Behl
D206,973 S	2/1967	De Lisio	5,868,197 A	2/1999	Potier
3,503,138 A	3/1970	Fuchs et al.	5,881,685 A	3/1999	Foss et al.
3,518,776 A	7/1970	Wolff et al.	D415,271 S	10/1999	Feer
3,724,092 A	4/1973	McCleerey	6,015,274 A	1/2000	Bias et al.
3,729,934 A	5/1973	Denning et al.	D423,663 S	4/2000	Rossmann et al.
3,743,186 A	7/1973	Mocarski	6,073,881 A	6/2000	Chen
3,795,367 A	3/1974	Mocarski	D429,808 S	8/2000	Krauss et al.
3,872,916 A	3/1975	Beck	6,123,618 A	9/2000	Day
3,875,745 A	4/1975	Franklin	6,155,782 A	12/2000	Hsu
3,885,891 A	5/1975	Thronson	D435,899 S	1/2001	Melwani
3,943,329 A	3/1976	Hlavac	6,254,337 B1	7/2001	Arnold
4,037,991 A	7/1977	Taylor	6,269,549 B1	8/2001	Carlucci et al.
4,046,492 A	9/1977	Inglis	6,278,248 B1	8/2001	Hong et al.
4,061,188 A	12/1977	Beck	6,282,746 B1	9/2001	Schleeter
4,073,613 A	2/1978	Desty	6,293,121 B1	9/2001	Labrador
4,090,814 A	5/1978	Teodorescu et al.	6,321,034 B2	11/2001	Jones-Lawlor et al.
4,113,416 A	9/1978	Kataoka et al.	6,386,845 B1	5/2002	Bedard
4,136,735 A	1/1979	Beck et al.	6,480,672 B1	11/2002	Rosenzweig et al.
4,173,995 A	11/1979	Beck	6,599,088 B2	7/2003	Stagg
4,180,130 A	12/1979	Beck et al.	6,604,694 B1	8/2003	Kordas et al.
4,184,417 A	1/1980	Chancellor	D483,851 S	12/2003	Fok
4,184,541 A	1/1980	Beck et al.	D485,895 S	1/2004	Melwani
4,192,461 A	3/1980	Arborg	D486,903 S	2/2004	Chiang
4,332,529 A	6/1982	Alperin	6,789,787 B2	9/2004	Stutts
4,336,017 A	6/1982	Desty	6,791,056 B2	9/2004	VanOtteren et al.
4,342,204 A	8/1982	Melikian et al.	6,830,433 B2	12/2004	Birdsell et al.
4,448,354 A	5/1984	Reznick et al.	6,845,971 B2	1/2005	Bachert
4,568,243 A	2/1986	Schubert et al.	D512,772 S	12/2005	Lee
4,630,475 A	12/1986	Mizoguchi	D513,067 S	12/2005	Blateri
4,643,351 A	2/1987	Fukamachi et al.	7,059,826 B2	6/2006	Lasko
4,703,152 A	10/1987	Shih-Chin	7,088,913 B1	8/2006	Verhoorn et al.
4,716,946 A	1/1988	Grigoletto	7,147,336 B1	12/2006	Chou
4,718,870 A	1/1988	Watts	D539,414 S *	3/2007	Russak et al. .... D23/411
4,732,539 A	3/1988	Shin-Chin	7,192,258 B2	3/2007	Kuo et al.
4,734,017 A	3/1988	Levin	7,198,473 B2	4/2007	Stickland et al.
4,790,133 A	12/1988	Stuart	7,412,781 B2	8/2008	Mattinger et al.
4,850,804 A	7/1989	Huang	7,478,993 B2	1/2009	Hong et al.
4,878,620 A	11/1989	Tarleton	7,540,474 B1	6/2009	Huang et al.
4,893,990 A	1/1990	Tomohiro et al.	D595,835 S	7/2009	Fu
4,978,281 A	12/1990	Conger	D598,532 S *	8/2009	Dyson et al. .... D23/370
5,061,405 A	10/1991	Stanek et al.	D602,143 S *	10/2009	Gammack et al. .... D23/370
D325,435 S	4/1992	Coup et al.	D602,144 S *	10/2009	Dyson et al. .... D23/370
			D605,748 S	12/2009	Gammack et al.
			7,660,110 B2	2/2010	Vinson et al.
			7,664,377 B2	2/2010	Liao
			D614,280 S	4/2010	Dyson et al.

(56)

References Cited

U.S. PATENT DOCUMENTS

7,731,050 B2	6/2010	Parks et al.	2009/0039805 A1	2/2009	Tang
7,775,848 B1	8/2010	Auerbach	2009/0060710 A1	3/2009	Gammack et al.
7,806,388 B2	10/2010	Junkel et al.	2009/0060711 A1	3/2009	Gammack et al.
7,841,045 B2	11/2010	Shaanan et al.	2009/0078120 A1	3/2009	Kummer et al.
D633,997 S	3/2011	Hideharu et al.	2009/0120925 A1	5/2009	Lasko
D633,999 S	3/2011	Hideharu et al.	2009/0191054 A1	7/2009	Winkler
7,931,449 B2	4/2011	Fitton et al.	2009/0214341 A1	8/2009	Craig
D638,114 S *	5/2011	Li et al. .... D23/370	2010/0133707 A1	6/2010	Huang
D643,098 S *	8/2011	Wallace et al. .... D23/342	2010/0150699 A1	6/2010	Nicolas et al.
8,002,520 B2	8/2011	Dawson et al.	2010/0162011 A1	6/2010	Min
D646,373 S	10/2011	Liebson et al.	2010/0171465 A1	7/2010	Seal et al.
8,092,166 B2	1/2012	Nicolas et al.	2010/0225012 A1	9/2010	Fitton et al.
8,113,490 B2	2/2012	Chen	2010/0226749 A1	9/2010	Gammack et al.
8,152,495 B2	4/2012	Bogges, Jr. et al.	2010/0226750 A1	9/2010	Gammack
8,246,317 B2	8/2012	Gammack	2010/0226751 A1	9/2010	Gammack et al.
D669,164 S *	10/2012	Hsu .... D23/411	2010/0226752 A1*	9/2010	Gammack et al. .... 415/90
8,308,445 B2	11/2012	Gammack et al.	2010/0226753 A1	9/2010	Dyson et al.
D672,023 S *	12/2012	Wallace et al. .... D23/370	2010/0226754 A1	9/2010	Hutton et al.
D672,024 S *	12/2012	Fitton et al. .... D23/370	2010/0226758 A1	9/2010	Cookson et al.
8,348,629 B2	1/2013	Fitton et al.	2010/0226763 A1	9/2010	Gammack et al.
8,356,804 B2	1/2013	Fitton et al.	2010/0226764 A1	9/2010	Gammack et al.
D678,993 S *	3/2013	Kung-Hua .... D23/370	2010/0226769 A1*	9/2010	Helps .... 415/208.1
8,403,640 B2 *	3/2013	Gammack et al. .... 415/211.2	2010/0226771 A1	9/2010	Crawford et al.
8,408,869 B2	4/2013	Hutton et al.	2010/0226787 A1	9/2010	Gammack et al.
D681,793 S	5/2013	Li	2010/0226797 A1*	9/2010	Fitton et al. .... 417/313
D684,249 S	6/2013	Herbst	2010/0226801 A1*	9/2010	Gammack .... 417/423.1
8,454,322 B2	6/2013	Gammack et al.	2010/0254800 A1	10/2010	Fitton et al.
8,469,660 B2	6/2013	Dyson et al.	2011/0058935 A1	3/2011	Gammack et al.
8,529,226 B2	9/2013	Li	2011/0110805 A1	5/2011	Gammack et al.
8,544,826 B2	10/2013	Ediger et al.	2011/0164959 A1	7/2011	Fitton et al.
D700,959 S	3/2014	Sickinger et al.	2011/0223014 A1	9/2011	Crawford et al.
8,684,687 B2	4/2014	Dyson et al.	2011/0223015 A1	9/2011	Gammack et al.
D705,415 S *	5/2014	Lo .... D23/370	2011/0236228 A1	9/2011	Fitton et al.
8,721,286 B2	5/2014	Gammack et al.	2012/0031509 A1*	2/2012	Wallace et al. .... 137/338
8,721,307 B2	5/2014	Li	2012/0033952 A1*	2/2012	Wallace et al. .... 392/367
8,764,412 B2	7/2014	Gammack et al.	2012/0034108 A1*	2/2012	Wallace et al. .... 417/313
8,783,663 B2	7/2014	Fitton et al.	2012/0039705 A1	2/2012	Gammack
8,784,071 B2 *	7/2014	Gammack .... 417/84	2012/0045315 A1	2/2012	Gammack
2002/0104972 A1	8/2002	Guzorek	2012/0045316 A1	2/2012	Gammack
2002/0106547 A1	8/2002	Sugawara et al.	2012/0057959 A1	3/2012	Hodgson et al.
2003/0059307 A1	3/2003	Moreno et al.	2012/0082561 A1	4/2012	Gammack et al.
2003/0164367 A1	9/2003	Bucher et al.	2012/0093629 A1	4/2012	Fitton et al.
2003/0171093 A1	9/2003	Gumucio Del Pozo	2012/0093630 A1	4/2012	Fitton et al.
2003/0190183 A1	10/2003	Hsing	2012/0114513 A1	5/2012	Simmonds et al.
2004/0022631 A1	2/2004	Birdsell et al.	2012/0230658 A1*	9/2012	Fitton et al. .... 392/361
2004/0049842 A1	3/2004	Prehodka	2012/0308375 A1	12/2012	Gammack
2004/0106370 A1	6/2004	Honda et al.	2013/0011252 A1	1/2013	Crawford et al.
2004/0149881 A1	8/2004	Allen	2013/0026664 A1	1/2013	Staniforth et al.
2005/0031448 A1	2/2005	Lasko et al.	2013/0028763 A1	1/2013	Staniforth et al.
2005/0053465 A1	3/2005	Roach et al.	2013/0028766 A1	1/2013	Staniforth et al.
2005/0069407 A1	3/2005	Winkler et al.	2013/0129490 A1	5/2013	Dos Reis et al.
2005/0128698 A1	6/2005	Huang	2013/0142676 A1	6/2013	Zou
2005/0163670 A1	7/2005	Alleyne et al.	2013/0161842 A1	6/2013	Fitton et al.
2005/0173997 A1	8/2005	Schmid et al.	2013/0199372 A1	8/2013	Nock et al.
2005/0281672 A1	12/2005	Parker et al.	2013/0234346 A1	9/2013	Staniforth et al.
2006/0172682 A1	8/2006	Orr et al.	2013/0234347 A1	9/2013	Staniforth et al.
2006/0199515 A1	9/2006	Lasko et al.	2013/0249122 A1	9/2013	Staniforth et al.
2006/0263073 A1	11/2006	Clarke et al.	2013/0249124 A1	9/2013	Staniforth et al.
2006/0279927 A1	12/2006	Strohm	2013/0249126 A1	9/2013	Staniforth et al.
2007/0035189 A1	2/2007	Matsumoto	2013/0272858 A1	10/2013	Stickney et al.
2007/0041857 A1	2/2007	Fleig	2013/0280051 A1	10/2013	Nicolas et al.
2007/0065280 A1	3/2007	Fok	2013/0280061 A1	10/2013	Stickney
2007/0166160 A1	7/2007	Russak et al.	2013/0280096 A1	10/2013	Gammack et al.
2007/0176502 A1	8/2007	Kasai et al.	2013/0309065 A1	11/2013	Johnson et al.
2007/0224044 A1	9/2007	Hong et al.	2013/0309080 A1	11/2013	Johnson et al.
2007/0237500 A1	10/2007	Wang	2013/0323100 A1	12/2013	Poulton et al.
2007/0269323 A1	11/2007	Zhou et al.	2013/0336771 A1	12/2013	Dyson et al.
2008/0020698 A1	1/2008	Spaggiari	2014/0017069 A1	1/2014	Peters
2008/0124060 A1	5/2008	Gao	2014/0077398 A1	3/2014	Staniforth et al.
2008/0152482 A1	6/2008	Patel	2014/0079566 A1	3/2014	Gammack et al.
2008/0166224 A1	7/2008	Giffin	2014/0084492 A1*	3/2014	Staniforth et al. .... 261/31
2008/0286130 A1	11/2008	Purvines	2014/0210114 A1	7/2014	Staniforth et al.
2008/0314250 A1	12/2008	Cowie et al.	2014/0210115 A1	7/2014	Staniforth et al.
2009/0026850 A1	1/2009	Fu			
2009/0032130 A1	2/2009	Dumas et al.			

(56)

## References Cited

## U.S. PATENT DOCUMENTS

2014/0255173 A1 9/2014 Poulton et al.  
 2014/0255217 A1 9/2014 Li

## FOREIGN PATENT DOCUMENTS

CA	2155482	9/1996	EP	1 094 224	4/2001
CH	346643	5/1960	EP	1 138 954	10/2001
CN	2085866	10/1991	EP	1357296	10/2003
CN	2111392	7/1992	EP	1 779 745	5/2007
CN	2549372	5/2003	EP	1 939 456	7/2008
CN	1437300	8/2003	EP	1 980 432	10/2008
CN	2650005	10/2004	EP	2 000 675	12/2008
CN	2713643	7/2005	EP	2191142	6/2010
CN	1680727	10/2005	EP	2 414 738	2/2012
CN	2833197	11/2006	EP	2 578 889	4/2013
CN	201011346	1/2008	FR	1033034	7/1953
CN	201147215	11/2008	FR	1119439	6/1956
CN	201180678	1/2009	FR	1387334	1/1965
CN	201221477	4/2009	FR	2 375 471	7/1978
CN	101424279	5/2009	FR	2 534 983	4/1984
CN	101451754	6/2009	FR	2 640 857	6/1990
CN	201281416	7/2009	FR	2 658 593	8/1991
CN	201349269	11/2009	FR	2794195	12/2000
CN	101684828	3/2010	FR	2 874 409	2/2006
CN	201486901	5/2010	FR	2 906 980	4/2008
CN	101749288	6/2010	FR	2928706	9/2009
CN	201502549	6/2010	GB	22235	0/1914
CN	201507461	6/2010	GB	383498	11/1932
CN	101825096	9/2010	GB	593828	10/1947
CN	101825101	9/2010	GB	601222	4/1948
CN	101825102	9/2010	GB	633273	12/1949
CN	101825103	9/2010	GB	641622	8/1950
CN	101825104	9/2010	GB	661747	11/1951
CN	201568337	9/2010	GB	863124	3/1961
CN	101858355	10/2010	GB	1067956	5/1967
CN	101936310	1/2011	GB	1 262 131	2/1972
CN	201696365	1/2011	GB	1 265 341	3/1972
CN	201696366	1/2011	GB	1 278 606	6/1972
CN	201739199	2/2011	GB	1 304 560	1/1973
CN	101984299	3/2011	GB	1 403 188	8/1975
CN	101985948	3/2011	GB	1 434 226	5/1976
CN	201763705	3/2011	GB	1 501 473	2/1978
CN	201763706	3/2011	GB	2 094 400	9/1982
CN	201770513	3/2011	GB	2 107 787	5/1983
CN	201771875	3/2011	GB	2 111 125	6/1983
CN	201779080	3/2011	GB	2 178 256	2/1987
CN	201786777	4/2011	GB	2 185 531	7/1987
CN	201786778	4/2011	GB	2 185 533	7/1987
CN	201802648	4/2011	GB	2 218 196	11/1989
CN	301539668	5/2011	GB	2 236 804	4/1991
CN	102095236	6/2011	GB	2 240 268	7/1991
CN	201858204	6/2011	GB	2 242 935	10/1991
CN	201874898	6/2011	GB	2 285 504	7/1995
CN	201874901	6/2011	GB	2 289 087	11/1995
CN	201917047	8/2011	GB	2383277	6/2003
CN	102251973	11/2011	GB	2 428 569	2/2007
CN	102287357	12/2011	GB	2 452 593	3/2009
CN	102367813	3/2012	GB	2452490	3/2009
CN	202267207	6/2012	GB	2463698	3/2010
CN	301949285	6/2012	GB	2464736	4/2010
CN	202431623	9/2012	GB	2466058	6/2010
DE	1 291 090	3/1969	GB	2468312	9/2010
DE	24 51 557	5/1976	GB	2468313	9/2010
DE	27 48 724	5/1978	GB	2468315	9/2010
DE	3644567	7/1988	GB	2468317	9/2010
DE	195 10 397	9/1996	GB	2468319	9/2010
DE	197 12 228	10/1998	GB	2468320	9/2010
DE	100 00 400	3/2001	GB	2468323	9/2010
DE	10041805	6/2002	GB	2468328	9/2010
DE	10 2009 007 037	8/2010	GB	2468329	9/2010
EP	0 044 494	1/1982	GB	2468331	9/2010
EP	0 186 581	7/1986	GB	2468369	9/2010
EP	0 459 812	12/1991	GB	2468498	9/2010
EP	0 784 947	7/1997	GB	2473037	3/2011
			GB	2479760	10/2011
			GB	2482547	2/2012
			GB	2484671	4/2012
			GB	2484695	4/2012
			GB	2484761	4/2012
			GB	2493231	1/2013
			GB	2493505	2/2013
			GB	2493507	2/2013
			GB	2500011	9/2013
			JP	31-13055	8/1956

(56)

## References Cited

## FOREIGN PATENT DOCUMENTS

JP	35-4369	3/1960
JP	39-7297	3/1964
JP	46-7230	12/1971
JP	47-21718	10/1972
JP	49-43764	4/1974
JP	49-150403	12/1974
JP	51-7258	1/1976
JP	52-121045	9/1977
JP	53-60100	5/1978
JP	56-167897	12/1981
JP	57-71000	5/1982
JP	57-157097	9/1982
JP	61-31830	2/1986
JP	61-116093	6/1986
JP	61-280787	12/1986
JP	62-98099	5/1987
JP	62-223494	10/1987
JP	63-36794	3/1988
JP	63-179198	7/1988
JP	63-198933	12/1988
JP	63-306340	12/1988
JP	64-21300	2/1989
JP	64-58955	3/1989
JP	64-83884	3/1989
JP	1-138399	5/1989
JP	1-224598	9/1989
JP	2-146294	6/1990
JP	2-218890	8/1990
JP	2-248690	10/1990
JP	3-52515	5/1991
JP	3-267598	11/1991
JP	3-286775	12/1991
JP	4-43895	2/1992
JP	4-366330	12/1992
JP	5-99386	4/1993
JP	5-157093	6/1993
JP	5-164089	6/1993
JP	5-263786	10/1993
JP	6-74190	3/1994
JP	6-86898	3/1994
JP	6-147188	5/1994
JP	6-257591	9/1994
JP	6-280800	10/1994
JP	6-336113	12/1994
JP	7-190443	7/1995
JP	8-21400	1/1996
JP	8-72525	3/1996
JP	8-313019	11/1996
JP	9-100800	4/1997
JP	9-178083	7/1997
JP	9-287600	11/1997
JP	11-502586	3/1999
JP	11-227866	8/1999
JP	2000-55419	2/2000
JP	2000-116179	4/2000
JP	2000-201723	7/2000
JP	2001-17358	1/2001
JP	2002-21797	1/2002
JP	2002-138829	5/2002
JP	2002-213388	7/2002
JP	2003-4265	1/2003
JP	2003-329273	11/2003
JP	2004-8275	1/2004
JP	2004-208935	7/2004
JP	2004-216221	8/2004
JP	2005-201507	7/2005
JP	2005-307985	11/2005
JP	2006-89096	4/2006
JP	2006-189221	7/2006
JP	3127331	11/2006
JP	2007-138763	6/2007
JP	2007-138789	6/2007
JP	2008-39316	2/2008
JP	2008-100204	5/2008
JP	3144127	8/2008

JP	3146538	10/2008
JP	2008-294243	12/2008
JP	2009-44568	2/2009
JP	2009-62986	3/2009
JP	D1371413	10/2009
JP	2009-275925	11/2009
JP	D1376284	12/2009
JP	2010-46411	3/2010
JP	2010-131259	6/2010
JP	2010-203760	9/2010
JP	2010-203764	9/2010
JP	2012-31806	2/2012
KR	1999-002660	1/1999
KR	10-2005-0102317	10/2005
KR	2007-0007997	1/2007
KR	20-0448319	3/2010
KR	10-2010-0055611	5/2010
KR	10-0985378	9/2010
TW	517825	1/2003
TW	589932	6/2004
TW	M394383	12/2010
TW	M399207	3/2011
TW	M407299	7/2011
WO	WO-90/13478	11/1990
WO	WO-95/06822	3/1995
WO	WO-02/073096	9/2002
WO	WO-03/058795	7/2003
WO	WO-03/069931	8/2003
WO	WO-2005/050026	6/2005
WO	WO-2005/057091	6/2005
WO	WO-2006/008021	1/2006
WO	WO-2006/012526	2/2006
WO	WO-2007/024955	3/2007
WO	WO-2007/048205	5/2007
WO	WO-2008/014641	2/2008
WO	WO-2008/024569	2/2008
WO	WO-2008/139491	11/2008
WO	WO-2009/030879	3/2009
WO	WO-2009/030881	3/2009
WO	WO-2010/100449	9/2010
WO	WO-2010/100451	9/2010
WO	WO-2010/100452	9/2010
WO	WO-2010/100453	9/2010
WO	WO-2010/100462	9/2010
WO	WO-2011/050041	4/2011
WO	WO-2011/147318	12/2011
WO	WO-2012/006882	1/2012
WO	WO-2012/033517	3/2012
WO	WO-2012/052737	4/2012
WO	WO-2013/014419	1/2013
WO	WO-2013/132218	9/2013

## OTHER PUBLICATIONS

Dos Reis et al., U.S. Office Action mailed Sep. 23, 2014, directed to U.S. Appl. No. 29/466,240; 9 pages.

Dos Reis et al., U.S. Office Action mailed Sep. 24, 2014, directed to U.S. Appl. No. 29/466,229; 9 pages.

Dos Reis et al., U.S. Office Action mailed Sep. 19, 2014, directed to U.S. Appl. No. 29/466,190; 9 pages.

Mcperson et al., U.S. Office Action mailed Sep. 19, 2014, directed to U.S. Appl. No. 29/466,094; 8 pages.

Mcperson et al., U.S. Office Action mailed Sep. 19, 2014, directed to U.S. Appl. No. 29/466,241; 8 pages.

Mcperson et al., U.S. Office Action mailed Sep. 19, 2014, directed to U.S. Appl. No. 29/466,253; 7 pages.

Dyson et al., U.S. Office Action mailed Sep. 12, 2014, directed to U.S. Appl. No. 29/480,915; 9 pages.

Poulton et al., U.S. Office Action mailed Sep. 12, 2014, directed to U.S. Appl. No. 29/480,919; 10 pages.

Deniss. (Sep. 9, 2010) "iFan, The Chinese Clone of the Dyson Air Multiplier," located at <<http://chinitech.com/en/chinese-clones/ifan-le-clone-chinois-du-dyson-air-multiplier>> visited on Aug. 29, 2014. (6 pages).

Amee. (Mar. 29, 2012) "Breeze Right Bladeless Fan Up to 41% Off," located at <<http://madamedeals.com/breeze-right-bladeless-fan-up-to-41-off/>> visited on Sep. 3, 2014. (2 pages).

(56)

**References Cited**

## OTHER PUBLICATIONS

Questel. (Jun. 11, 2014) "Designs-Questel" located at <<http://sobjprd.questel.fr/export/QPTUJ214/pdf2/19f053ea-a60f-4c58-9232-c458147a9adf-224304.pdf>> visited on Sep. 4, 2014. (67 pages).

Steiner, L., (May 14, 2013) "Dyson Fan Heater Review: Cozy Up to Dyson Fan Heater," located at <<http://www.vissbiz.com/dyson-fan-heater-review/cozy-up-to-dyson-fan-heater/>> visited on Sep. 3, 2014. (3 pages).

Lee. (Nov. 15, 2011) "Fan with No Blades EBH107," located at <[http://www.weiku.com/products/12806615/Fan\\_With\\_No\\_Blades\\_EBH107.html](http://www.weiku.com/products/12806615/Fan_With_No_Blades_EBH107.html)> visited on Nov. 4, 2014. (4 pages).

Reba, I. (1966). "Applications of the Coanda Effect," *Scientific American* 214:84-92.

Third Party Submission Under 37 CFR 1.99 filed Jun. 2, 2011, directed to U.S. Appl. No. 12/203,698; 3 pages.

Gammack et al., U.S. Office Action mailed Dec. 9, 2010, directed to U.S. Appl. No. 12/203,698; 10 pages.

Gammack et al., U.S. Office Action mailed Jun. 21, 2011, directed to U.S. Appl. No. 12/203,698; 11 pages.

Gammack et al., U.S. Office Action mailed Sep. 17, 2012, directed to U.S. Appl. No. 13/114,707; 12 pages.

Gammack et al., U.S. Office Action mailed Dec. 10, 2010, directed to U.S. Appl. No. 12/230,613; 12 pages.

Gammack et al., U.S. Office Action mailed May 13, 2011, directed to U.S. Appl. No. 12/230,613; 13 pages.

Gammack et al., U.S. Office Action mailed Sep. 7, 2011, directed to U.S. Appl. No. 12/230,613; 15 pages.

Gammack et al., U.S. Office Action mailed Jun. 8, 2012, directed to U.S. Appl. No. 12/230,613; 15 pages.

Gammack et al., U.S. Office Action mailed Aug. 20, 2012, directed to U.S. Appl. No. 12/945,558; 15 pages.

Gammack et al., U.S. Office Action mailed Feb. 28, 2013, directed to U.S. Appl. No. 12/945,558; 16 pages.

Gammack et al., U.S. Office Action mailed Jun. 12, 2013, directed to U.S. Appl. No. 12/945,558; 20 pages.

Fitton et al., U.S. Office Action mailed Nov. 30, 2010 directed to U.S. Appl. No. 12/560,232; 9 pages.

Nicolas et al., U.S. Office Action mailed Mar. 7, 2011, directed to U.S. Appl. No. 12/622,844; 10 pages.

Nicolas et al., U.S. Office Action mailed Sep. 8, 2011, directed to U.S. Appl. No. 12/622,844; 11 pages.

Helps et al., U.S. Office Action mailed Feb. 15, 2013, directed to U.S. Appl. No. 12/716,694; 12 pages.

Gammack et al., U.S. Office Action mailed Dec. 9, 2010, directed to U.S. Appl. No. 12/716,781; 17 pages.

Gammack et al., U.S. Office Action mailed Jun. 24, 2011, directed to U.S. Appl. No. 12/716,781; 19 pages.

Gammack et al., U.S. Office Action mailed May 29, 2013, directed to U.S. Appl. No. 13/588,666; 11 pages.

Gammack et al., U.S. Office Action mailed Sep. 27, 2013, directed to U.S. Appl. No. 13/588,666; 10 pages.

Gammack et al., U.S. Office Action mailed Mar. 14, 2013, directed to U.S. Appl. No. 12/716,740; 15 pages.

Gammack et al., U.S. Office Action mailed Sep. 6, 2013, directed to U.S. Appl. No. 12/716,740; 15 pages.

Gammack et al., U.S. Office Action mailed Apr. 24, 2014, directed to U.S. Appl. No. 12/716,740; 16 pages.

Li et al., U.S. Office Action mailed Oct. 25, 2013, directed to U.S. Appl. No. 13/686,480; 17 pages.

Fitton et al., U.S. Office Action mailed Jun. 13, 2014, directed to U.S. Appl. No. 13/274,998; 11 pages.

Fitton et al., U.S. Office Action mailed Jun. 13, 2014, directed to U.S. Appl. No. 13/275,034; 10 pages.

Gammack et al., U.S. Office Action mailed Feb. 14, 2013, directed to U.S. Appl. No. 12/716,515; 21 pages.

Gammack et al., U.S. Office Action mailed Aug. 19, 2013, directed to U.S. Appl. No. 12/716,515; 20 pages.

Gammack et al., U.S. Office Action mailed Feb. 10, 2014, directed to U.S. Appl. No. 12/716,515; 21 pages.

Fitton et al., U.S. Office Action mailed Mar. 30, 2012, directed to U.S. Appl. No. 12/716,707; 7 pages.

Fitton et al., U.S. Office Action mailed Dec. 31, 2013, directed to U.S. Appl. No. 13/718,693; 8 pages.

Staniforth et al., U.S. Office Action mailed Sep. 18, 2014, directed to U.S. Appl. No. 13/559,142; 18 pages.

Gammack et al., U.S. Office Action mailed Oct. 18, 2012, directed to U.S. Appl. No. 12/917,247; 11 pages.

Gammack et al., U.S. Office Action mailed Sep. 3, 2014, directed to U.S. Appl. No. 13/861,891; 7 pages.

Wallace et al., U.S. Office Action mailed Jun. 7, 2013, directed to U.S. Appl. No. 13/192,223; 30 pages.

Wallace et al., U.S. Office Action mailed Oct. 23, 2013, directed to U.S. Appl. No. 13/192,223; 18 pages.

Gammack et al., U.S. Office Action mailed Apr. 12, 2011, directed to U.S. Appl. No. 12/716,749; 8 pages.

Gammack et al., U.S. Office Action mailed Sep. 1, 2011, directed to U.S. Appl. No. 12/716,749; 9 pages.

Gammack et al., U.S. Office Action mailed Jun. 25, 2012, directed to U.S. Appl. No. 12/716,749; 11 pages.

Gammack et al., U.S. Office Action mailed May 24, 2011, directed to U.S. Appl. No. 12/716,613; 9 pages.

Fitton et al., U.S. Office Action mailed Mar. 8, 2011, directed to U.S. Appl. No. 12/716,780; 12 pages.

Fitton et al., U.S. Office Action mailed Sep. 6, 2011, directed to U.S. Appl. No. 12/716,780; 16 pages.

\* cited by examiner

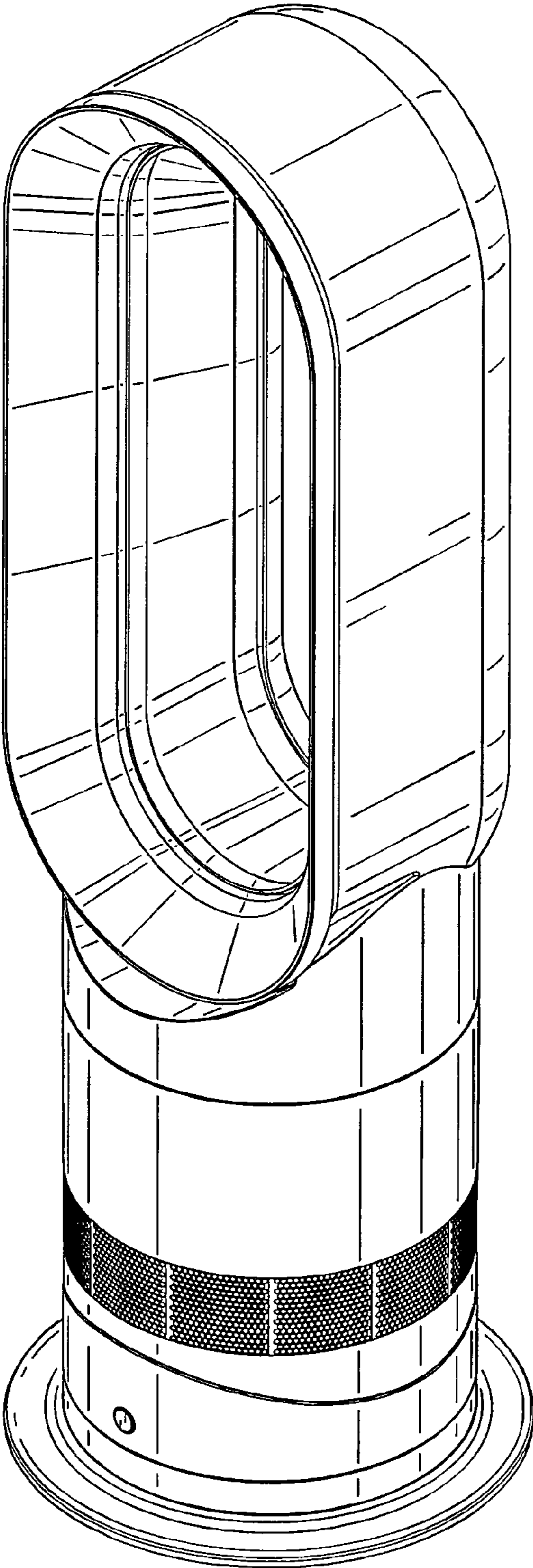

FIG. 1

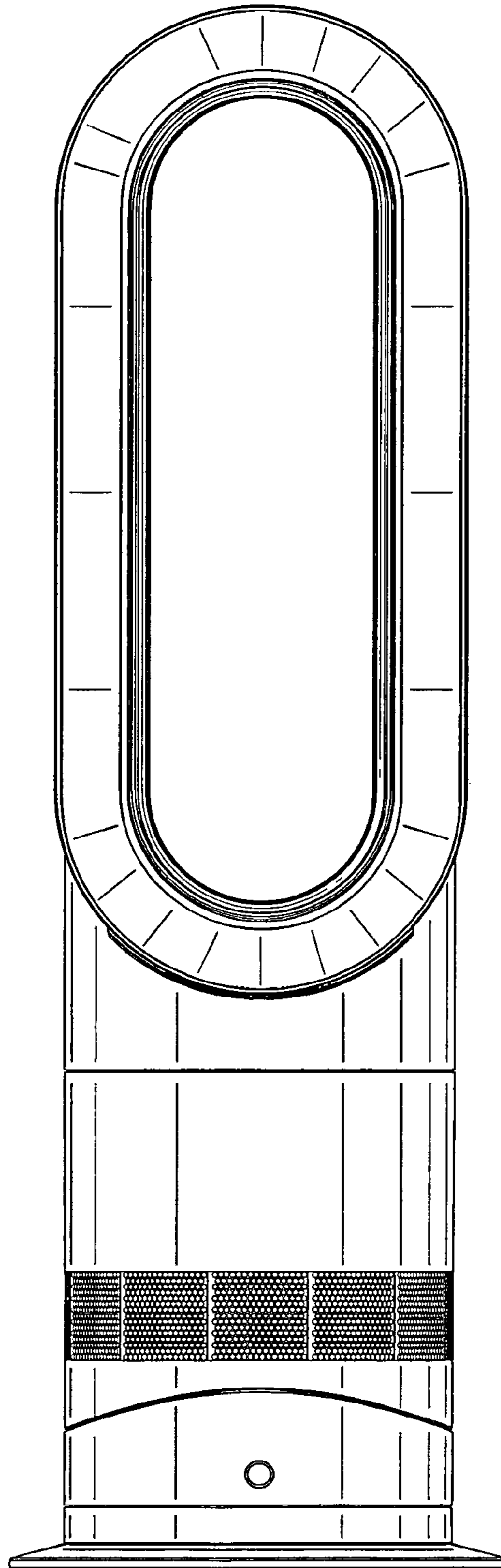

FIG. 2



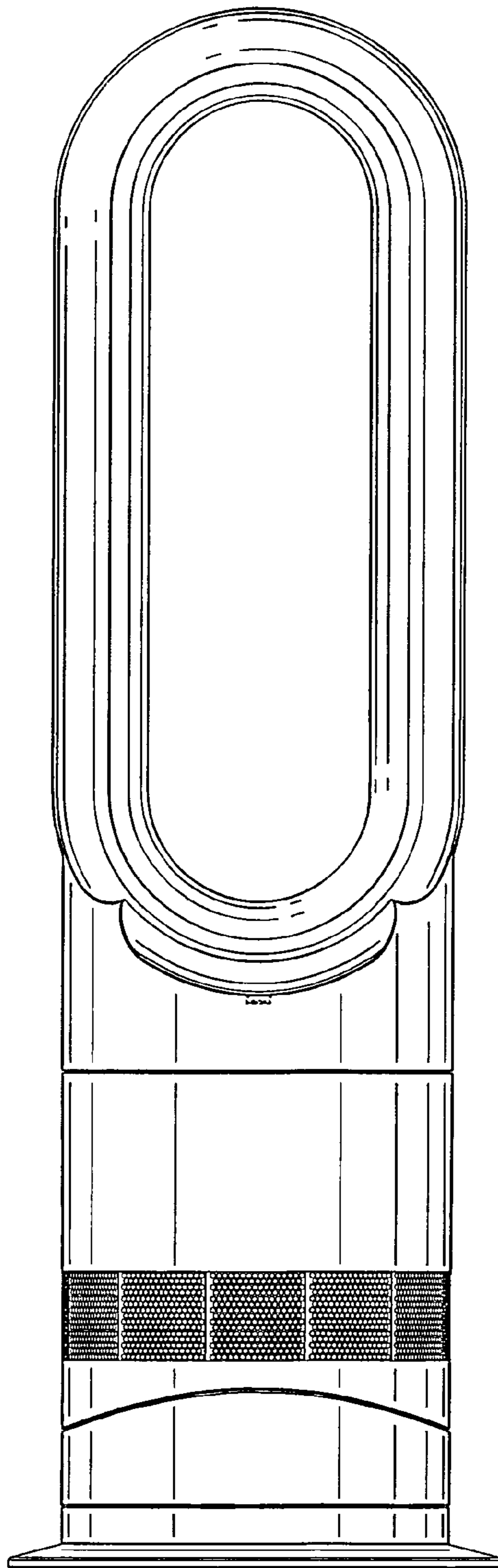

FIG. 3

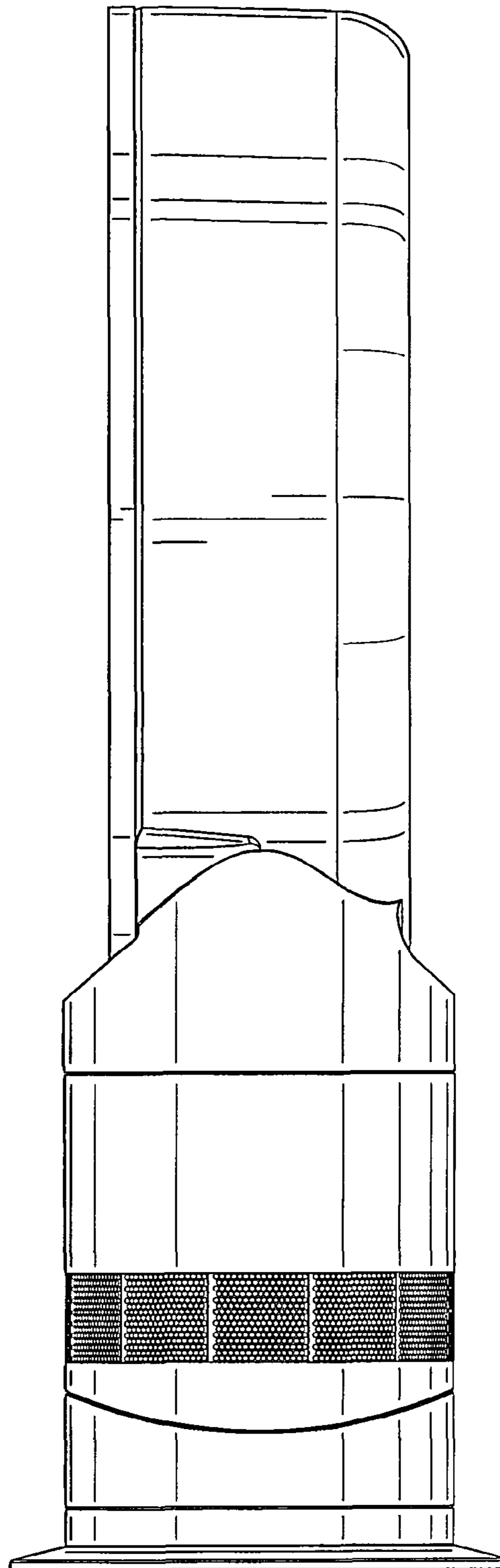

FIG. 4

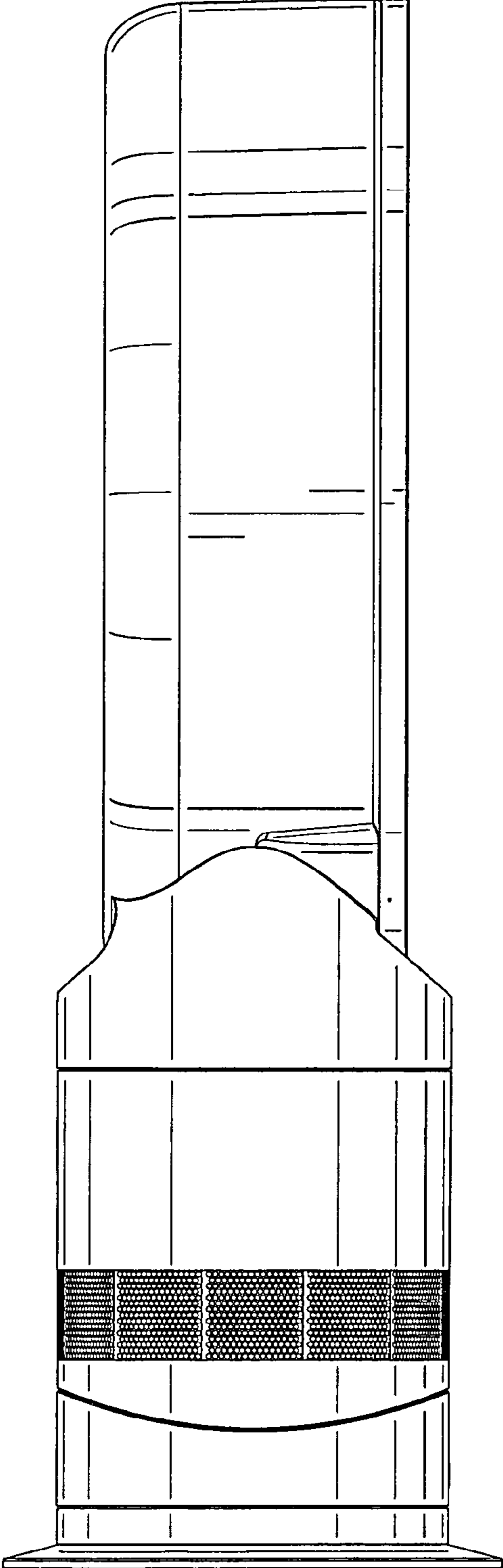

FIG. 5

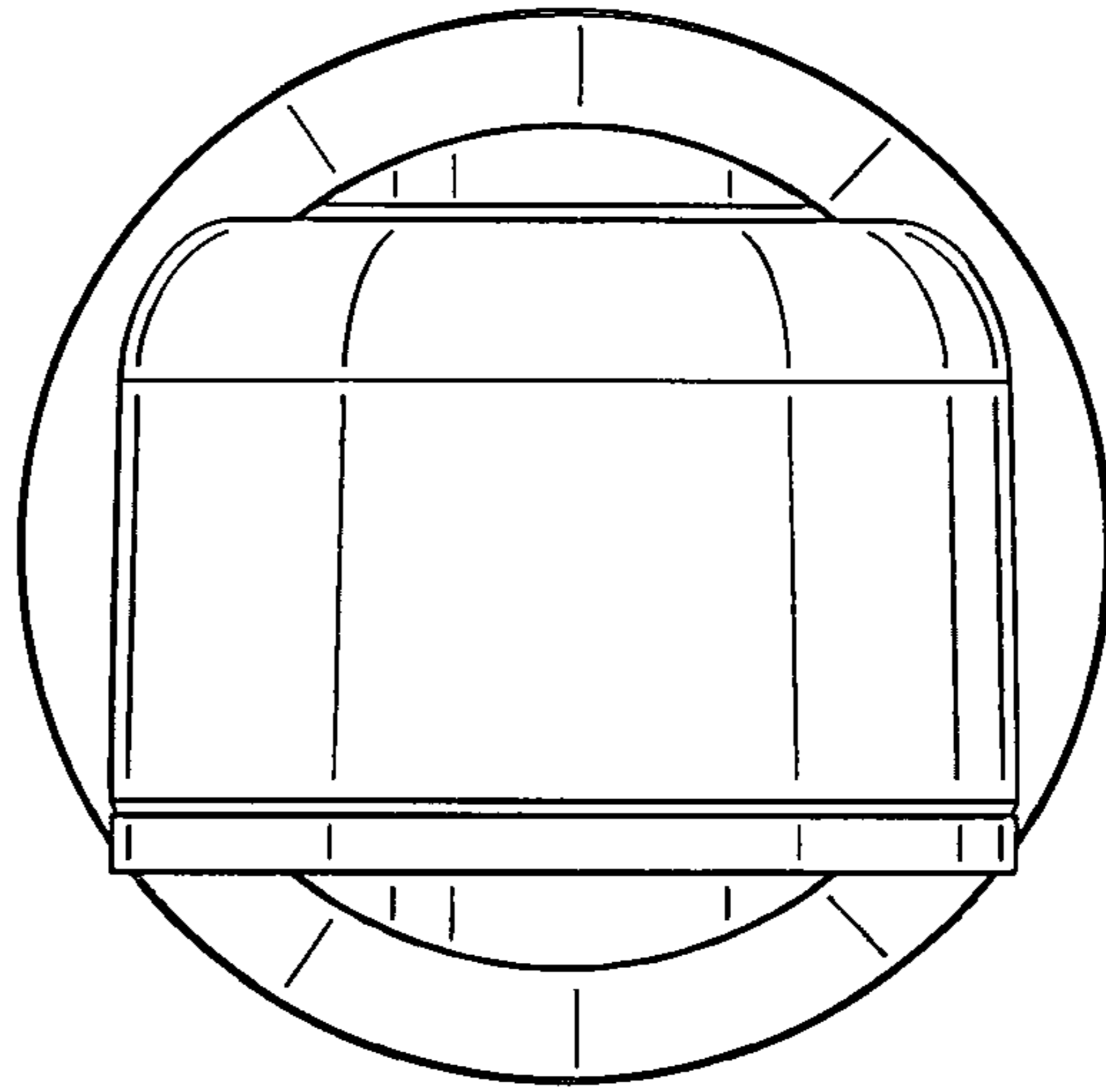

FIG. 6

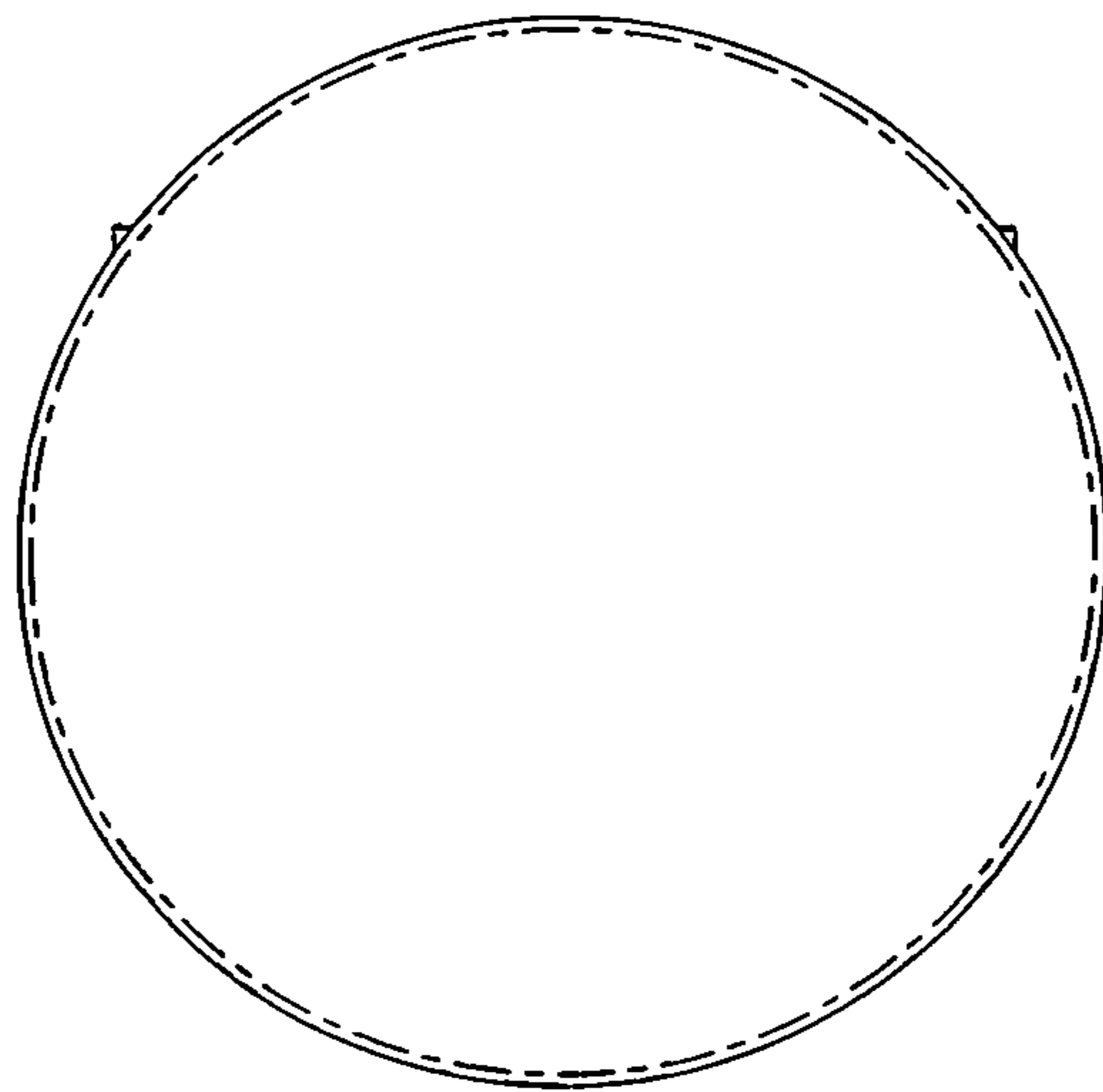

FIG. 7