



US00D728648S

(12) **United States Design Patent**
Kang et al.

(10) **Patent No.:** **US D728,648 S**

(45) **Date of Patent:** **** May 5, 2015**

(54) **RESISTANCE SPOT WELDING ELECTRODE**

(56) **References Cited**

(71) Applicant: **Korea Institute of Industrial Technology**, Chungcheongnam-do (KR)

U.S. PATENT DOCUMENTS

(72) Inventors: **Mun Jin Kang**, Incheon (KR); **Dong Cheol Kim**, Incheon (KR); **Cheol Hee Kim**, Incheon (KR); **Hyun Jun Yun**, Gyeonggi-do (KR)

D127,474	S	*	5/1941	Holden	D23/213
2,440,463	A	*	4/1948	Cornwall	219/119
D269,617	S	*	7/1983	Nippert	D15/144
D290,807	S	*	7/1987	Nippert	D8/30
D295,361	S	*	4/1988	Grant et al.	D8/30
5,266,776	A	*	11/1993	Boisvert et al.	219/121.39
5,310,988	A	*	5/1994	Couch et al.	219/121.52
D362,860	S	*	10/1995	Carkhuff	D15/144
D365,345	S	*	12/1995	Carkhuff	D15/144
D369,648	S	*	5/1996	Fowler	D23/213
D371,058	S	*	6/1996	Walters	D8/30
D384,682	S	*	10/1997	Turner et al.	D15/144
D409,211	S	*	5/1999	Hidaka	D15/144
D417,459	S	*	12/1999	Shintani et al.	D15/144
D420,374	S	*	2/2000	Zigliotto	D15/144
D446,530	S	*	8/2001	Kuraoka et al.	D15/144
D461,225	S	*	8/2002	Chen	D23/223
D520,106	S	*	5/2006	Jones et al.	D23/213
D520,107	S	*	5/2006	Jones et al.	D23/213
7,360,930	B2	*	4/2008	Yu	362/392
7,538,294	B2	*	5/2009	Scotchmer	219/119
7,828,462	B2	*	11/2010	Jensen et al.	362/249.02
D636,002	S	*	4/2011	Bruckner et al.	D15/144
8,471,169	B2	*	6/2013	Mukae et al.	219/86.1
D719,200	S	*	12/2014	Hassan	D15/144

(73) Assignee: **Korea Institute of Industrial Technology**, Cheonan-si, Chungcheongnam-do (KR)

(**) Term: **14 Years**

(21) Appl. No.: **29/439,649**

(22) Filed: **Dec. 13, 2012**

(30) **Foreign Application Priority Data**

Jun. 14, 2012 (KR) 30-2012-0029122

(51) **LOC (10) Cl.** **15-09**

(52) **U.S. Cl.**
CPC **H01T 13/20** (2013.01); **H01T 13/02** (2013.01); **H01T 13/00** (2013.01)

USPC **D15/144**

(58) **Field of Classification Search**

CPC B06B 1/00; B06B 2201/72; B06B 3/00; B29C 65/08; B01J 19/008; B01J 19/10; B23K 1/06; B23K 20/10; B23K 20/106; H01L 24/78; H01L 2224/48; H01L 2224/78; H01L 2924/01013; H01L 2924/01039; H01L 2924/01082; H01L 2924/00014; H01L 2924/01005; H01L 2924/01006; H01L 2924/01033

USPC 4/286, 288, 292, 496, 507-509, 541; 15/406; 29/890.141-890.143; 128/66; 156/73.1, 73.3, 580.1, 580.2; 165/95; 181/139, 142; 209/346, 365.1; 222/566; 228/1.1, 110.1; 239/428.5, 239/459, 525-528, 589, 602; 261/DIG. 75; 310/323.19, 325; 333/145; 604/22; D8/2, 70; D12/345; D15/144-144.2; D23/19, 34, 38, 41, 213, 223, 226

See application file for complete search history.

FOREIGN PATENT DOCUMENTS

KR	300696521.0000	*	6/2013
KR	300696522.0000	*	6/2013
KR	300696523.0000	*	6/2013

OTHER PUBLICATIONS

g_spotweld-pic-071.jpg [online]. www.basicwelding.org, 2012 [retrieved on Apr. 7, 2014]. Retrieved from the Internet: <URL: http://www.basicwelding.org/wp-content/uploads/2012/10/1g_spotweld-pic-071.jpg>.*
Cap Electrodes [online]. T.J. Snow Co., 2013 [retrieved on Apr. 7, 2014]. Retrieved from the Internet: <URL: http://www.tjsnow.com/supplies/centerline/centerline_electrodes.htm>.*
BB Series Full Cone Wide-angle Spray Nozzle [online]. Green Spray Technology, 2013 [retrieved on May 6, 2014]. Retrieved from the Internet: <URL: http://www.gsspraying.com/html/Full_1283_504.html>.*

* cited by examiner

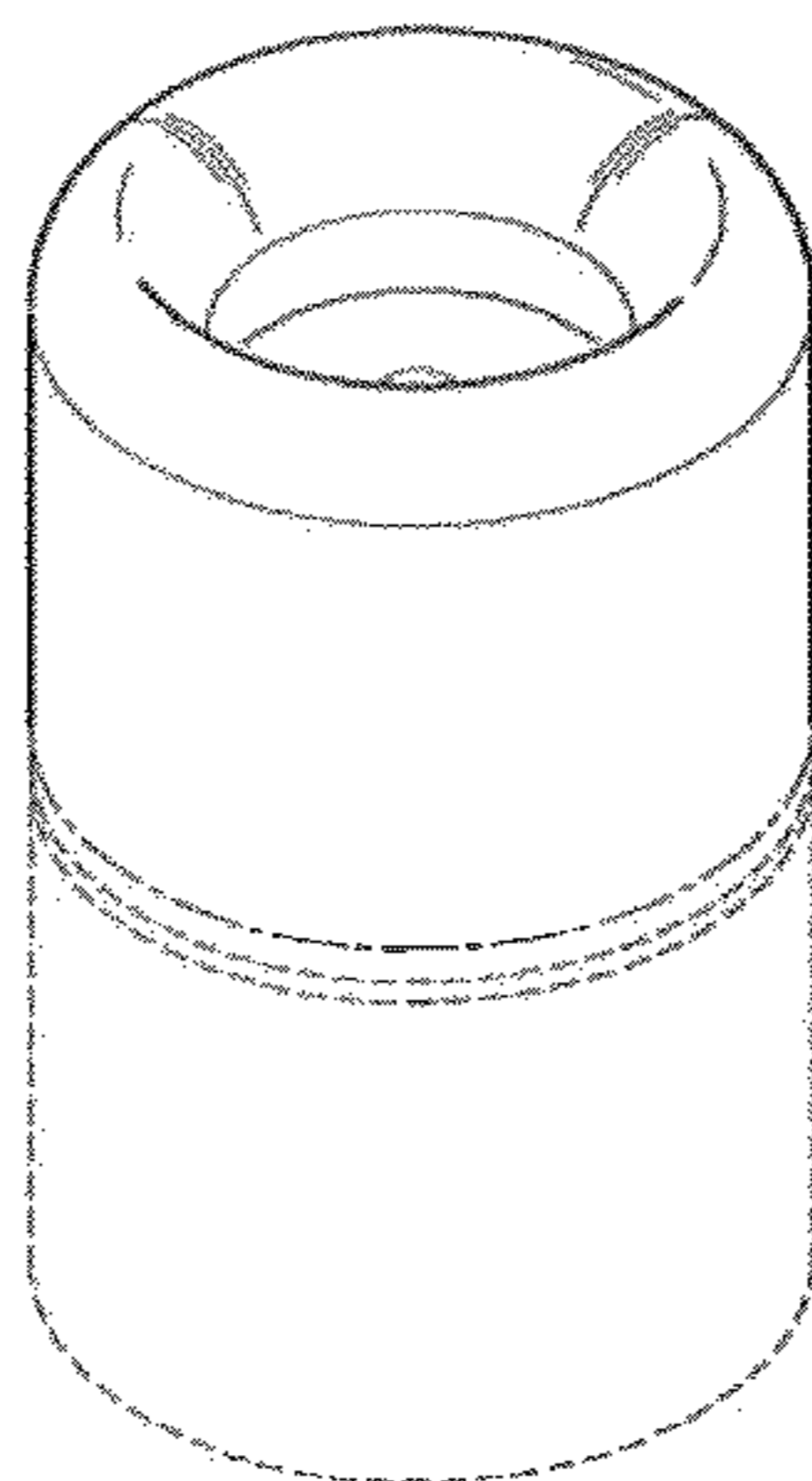

Primary Examiner — Deanna L Pratt
(74) Attorney, Agent, or Firm — Ladas & Parry LLP

(57)

CLAIM

The ornamental design for a resistance spot welding electrode, as shown and described.

DESCRIPTION

FIG. 1 is a perspective view of our new design for a resistance spot welding electrode;

FIG. 2 is a front view of the resistance spot welding electrode shown in FIG. 1;

FIG. 3 is a rear view of the resistance spot welding electrode shown in FIG. 1;

FIG. 4 is a top view of the resistance spot welding electrode shown in FIG. 1;

FIG. 5 is a bottom view of the resistance spot welding electrode shown in FIG. 1;

FIG. 6 is a left side view of the resistance spot welding electrode shown in FIG. 1;

FIG. 7 is a right side view of the resistance spot welding electrode shown in FIG. 1; and,

FIG. 8 is a cross-sectional view of the resistance spot welding electrode shown in FIG. 1.

The evenly-spaced broken lines illustrate portions of the resistance spot welding electrode which form no part of the claimed design. The dash-dot-dash-type broken line illustrates the boundary of the claim and forms no part thereof.

1 Claim, 4 Drawing Sheets

FIG. 1

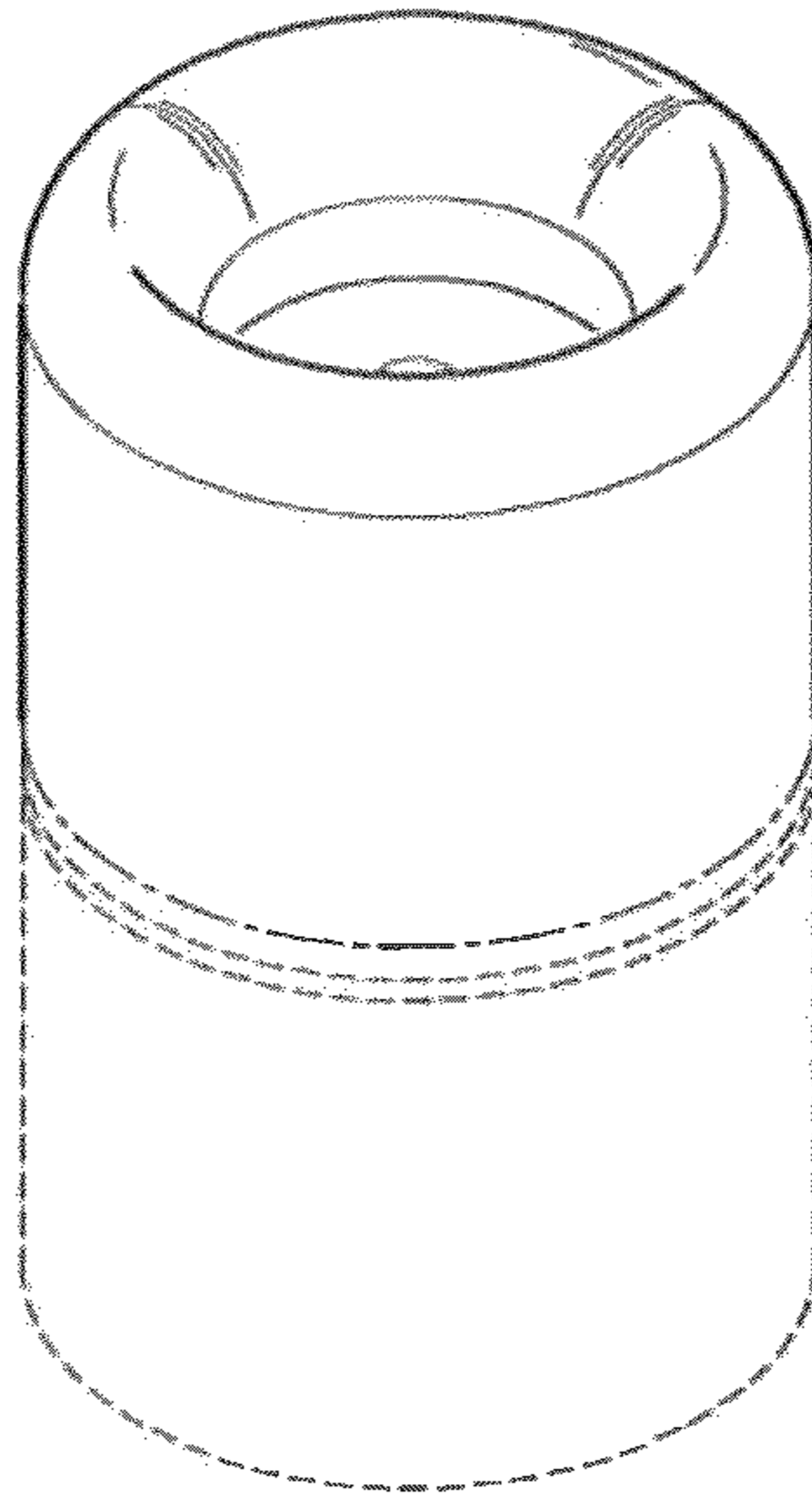

FIG. 2

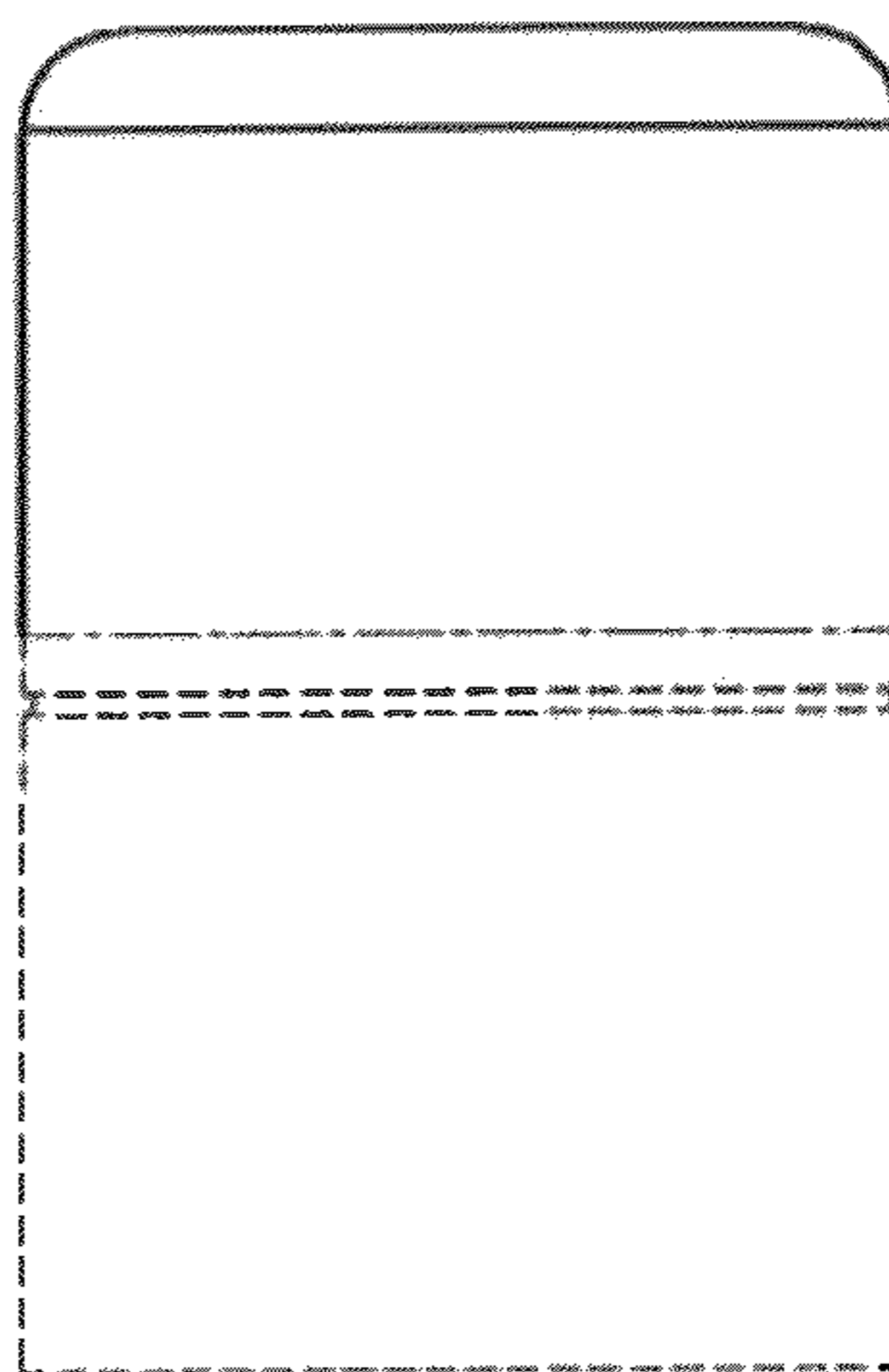

FIG. 3

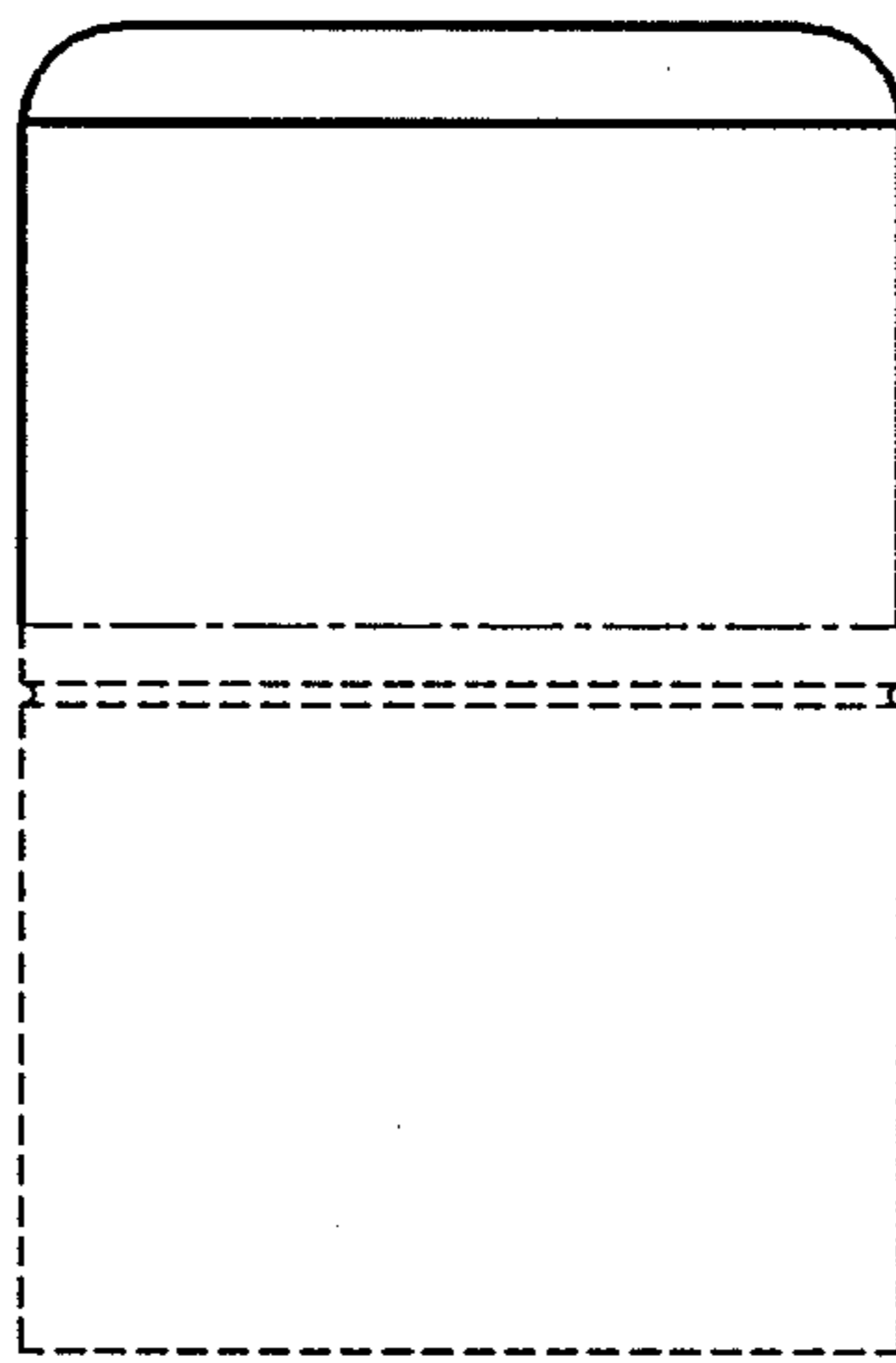

FIG. 4

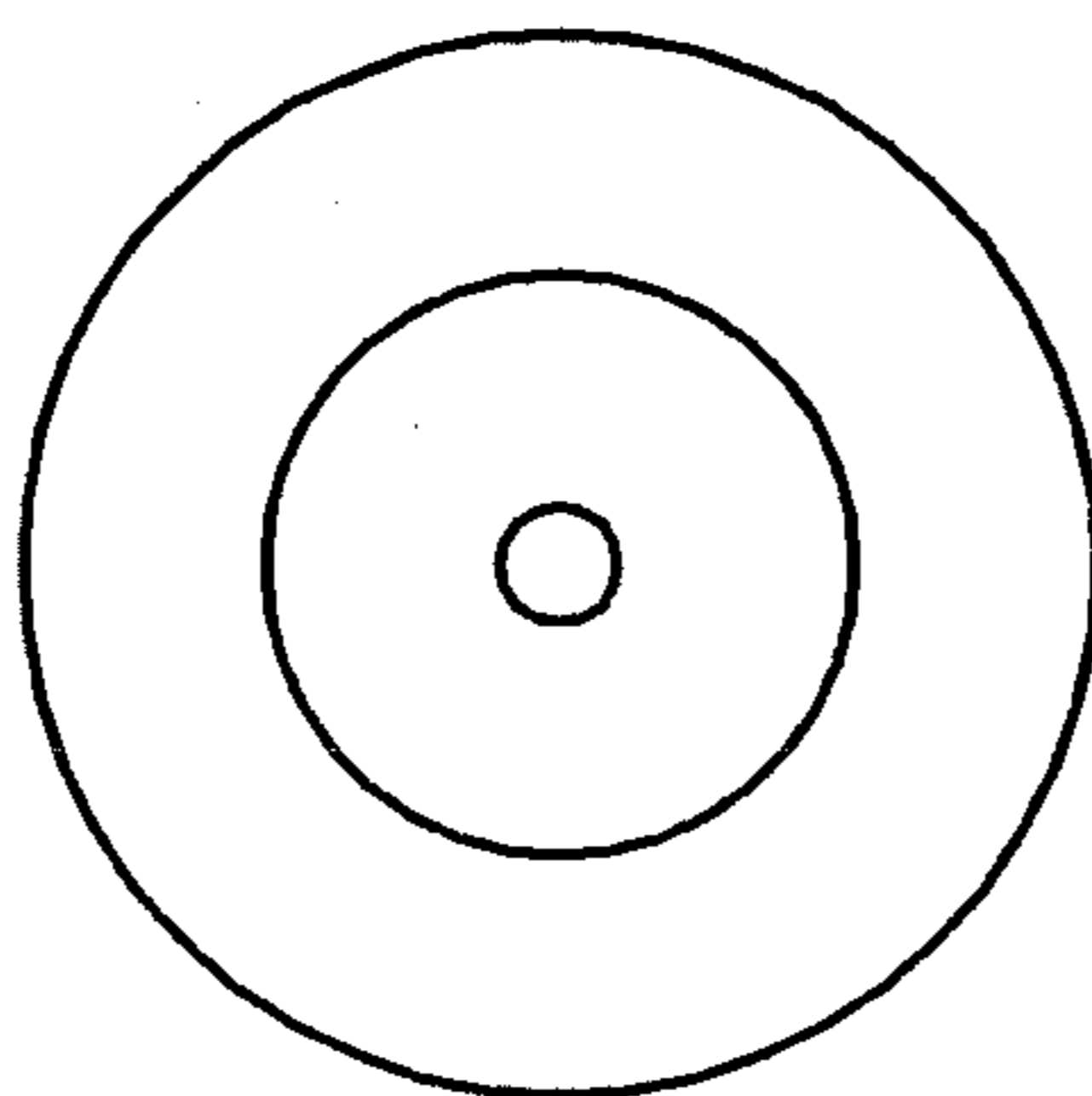

FIG. 5

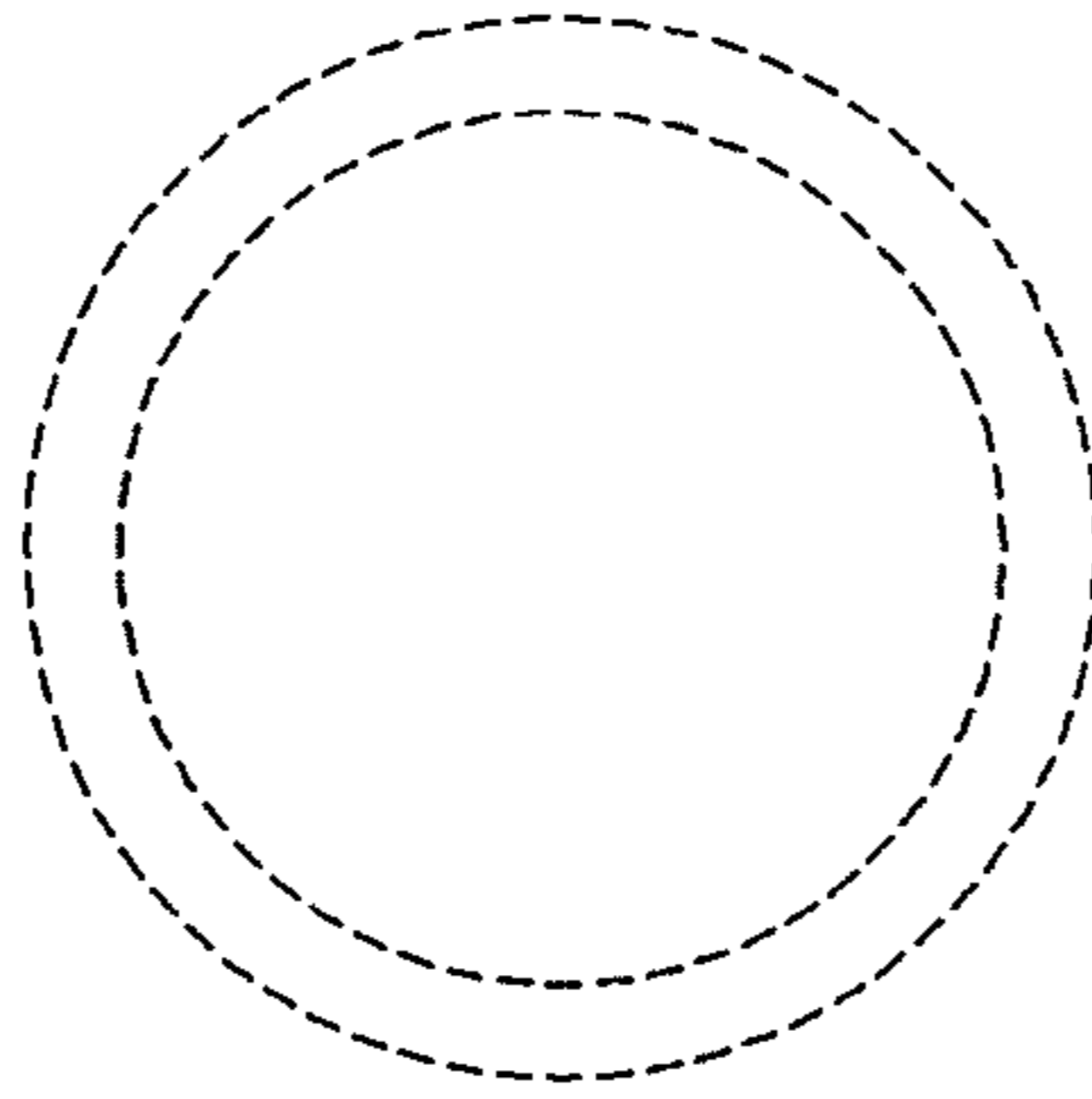

FIG. 6

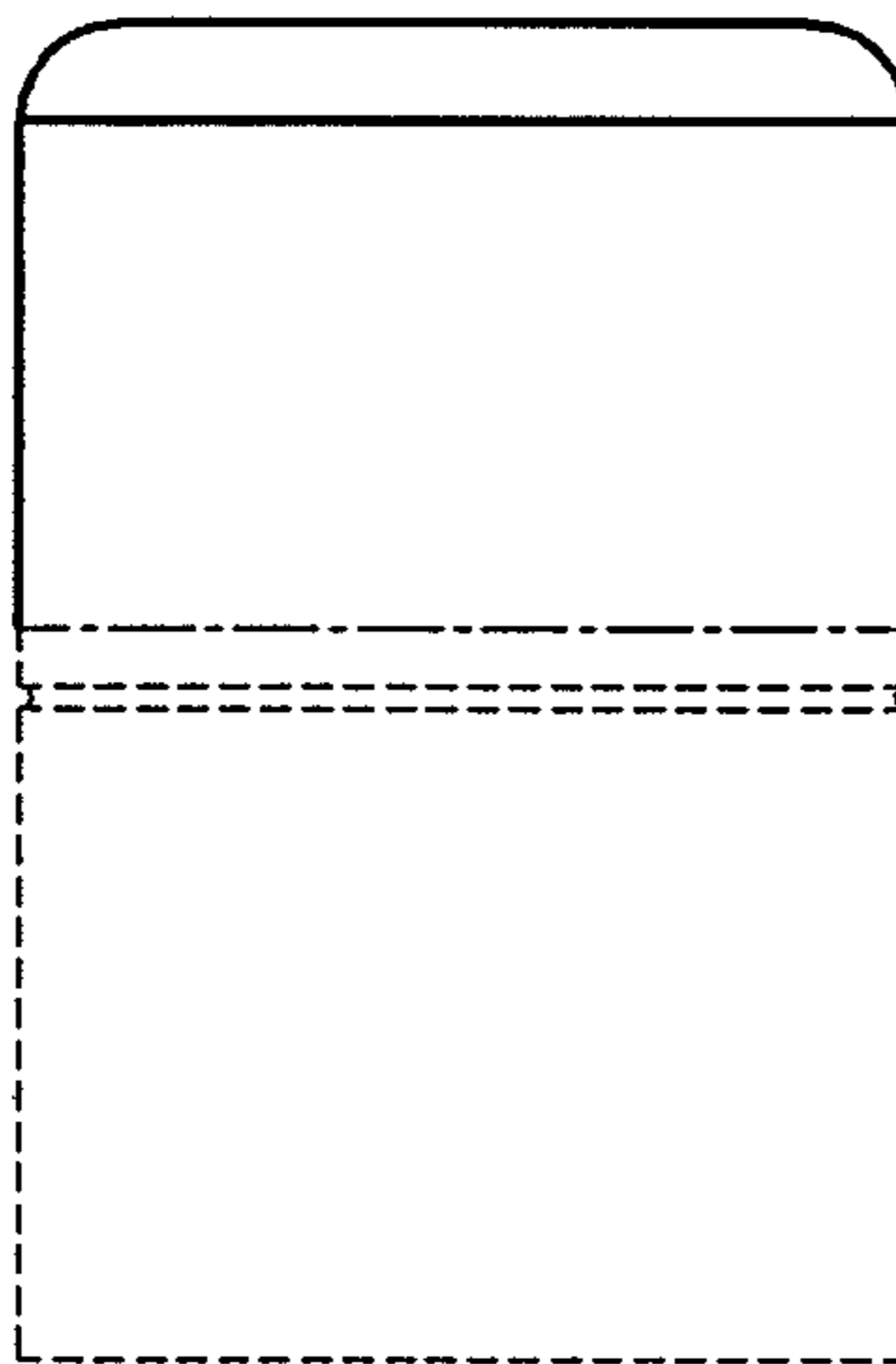

FIG. 7

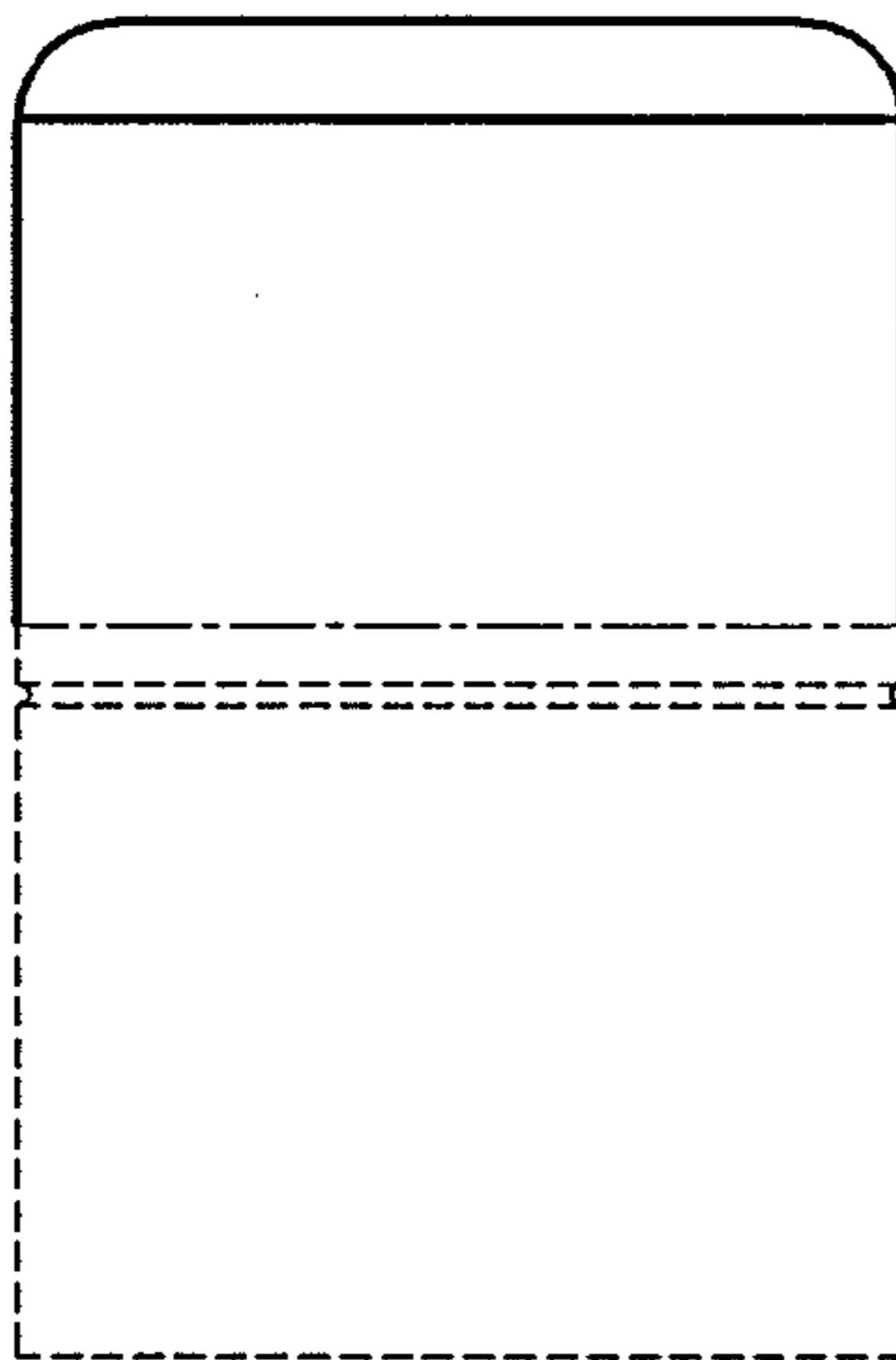

FIG. 8

