

US00D728452S

(12) **United States Design Patent**
Sano et al.

(10) **Patent No.:** **US D728,452 S**

(45) **Date of Patent:** **** May 5, 2015**

(54) **TREAD PORTION OF AN AUTOMOBILE TIRE**

(71) Applicant: **Bridgestone Corporation**, Chuo-ku, Tokyo (JP)

(72) Inventors: **Keisuke Sano**, Chuo-ku (JP); **Kenta Sumitomo**, Chuo-ku (JP)

(73) Assignee: **Bridgestone Corporation**, Tokyo (JP)

(**) Term: **14 Years**

(21) Appl. No.: **29/493,918**

(22) Filed: **Jun. 16, 2014**

(30) **Foreign Application Priority Data**

Feb. 20, 2014 (JP) 2014-003498

(51) **LOC (10) Cl.** **12-15**

(52) **U.S. Cl.**
USPC **D12/521; D12/524**

(58) **Field of Classification Search**
CPC B60C 11/0304; B60C 11/0302; B60C 11/0306; B60C 11/0309; B60C 11/0318; B60C 11/0311; B60C 11/042; B60C 11/13; B60C 11/00; B60C 11/11; B60C 11/12
USPC D12/505-532
See application file for complete search history.

(56) **References Cited**

U.S. PATENT DOCUMENTS

D546,272 S *	7/2007	Shinohara et al.	D12/521
D651,160 S *	12/2011	Jacobs	D12/524
D665,728 S *	8/2012	Kiwaki	D12/524
D667,358 S *	9/2012	Fontaine et al.	D12/524
D706,707 S *	6/2014	Jacobs	D12/524
D709,435 S *	7/2014	Jacobs	D12/524

* cited by examiner

Primary Examiner — Stacia Cadmus

(74) *Attorney, Agent, or Firm* — Sughrue Mion, PLLC

(57) **CLAIM**

The ornamental design for a tread portion of an automobile tire, as shown and described.

DESCRIPTION

FIG. 1 is a perspective view of a tread portion of an automobile tire showing our design;
FIG. 2 is a front view thereof;
FIG. 3 is a top view thereof;
FIG. 4 is a right side view thereof;
FIG. 5 is a left side view thereof;
FIG. 6 is a rear view thereof;
FIG. 7 is a fragmentary enlarged front view showing the details of the tread portion thereof; and,
FIG. 8 is a section view taken along line 8-8 in FIG. 7.
The broken lines are used to show portions of the tire that are not being claimed, and thus form no part of the claimed design.

1 Claim, 8 Drawing Sheets

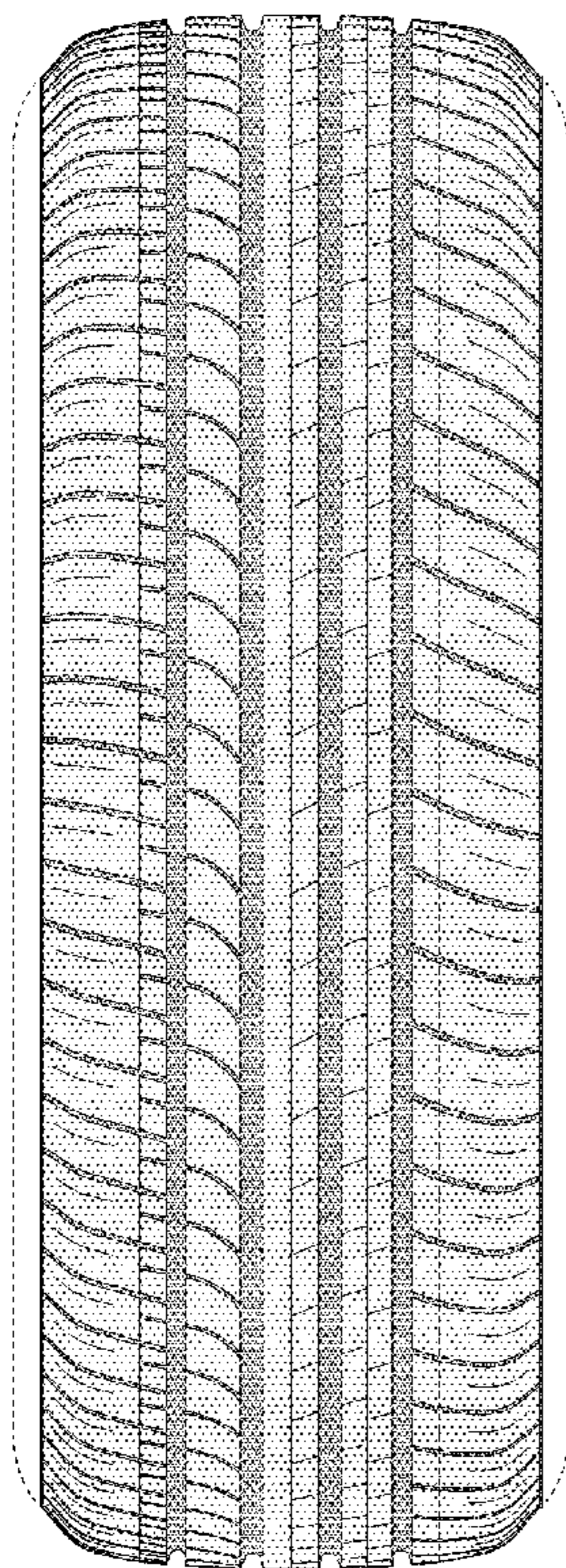

8
↑

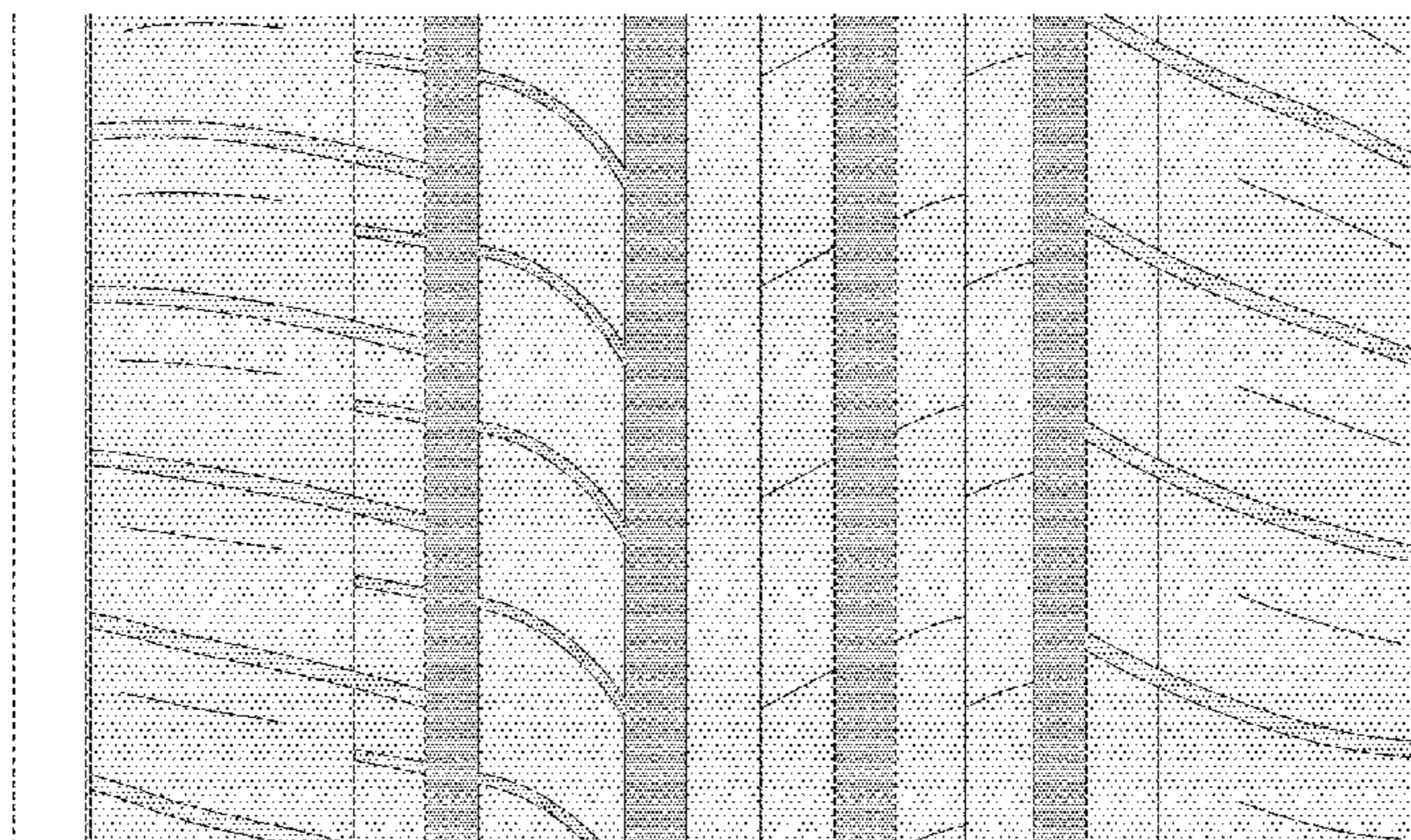

8
↑

FIG. 1

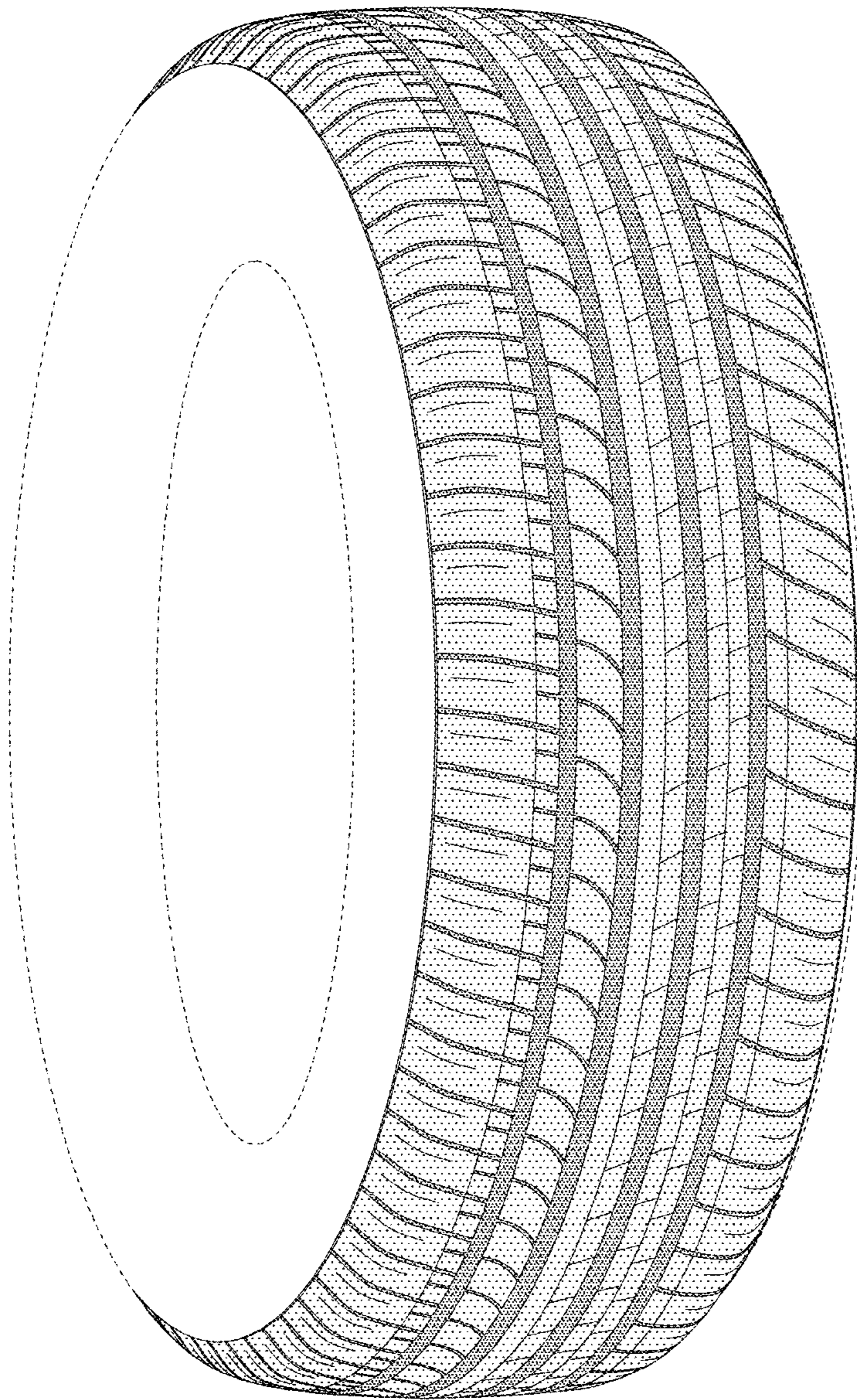

FIG. 2

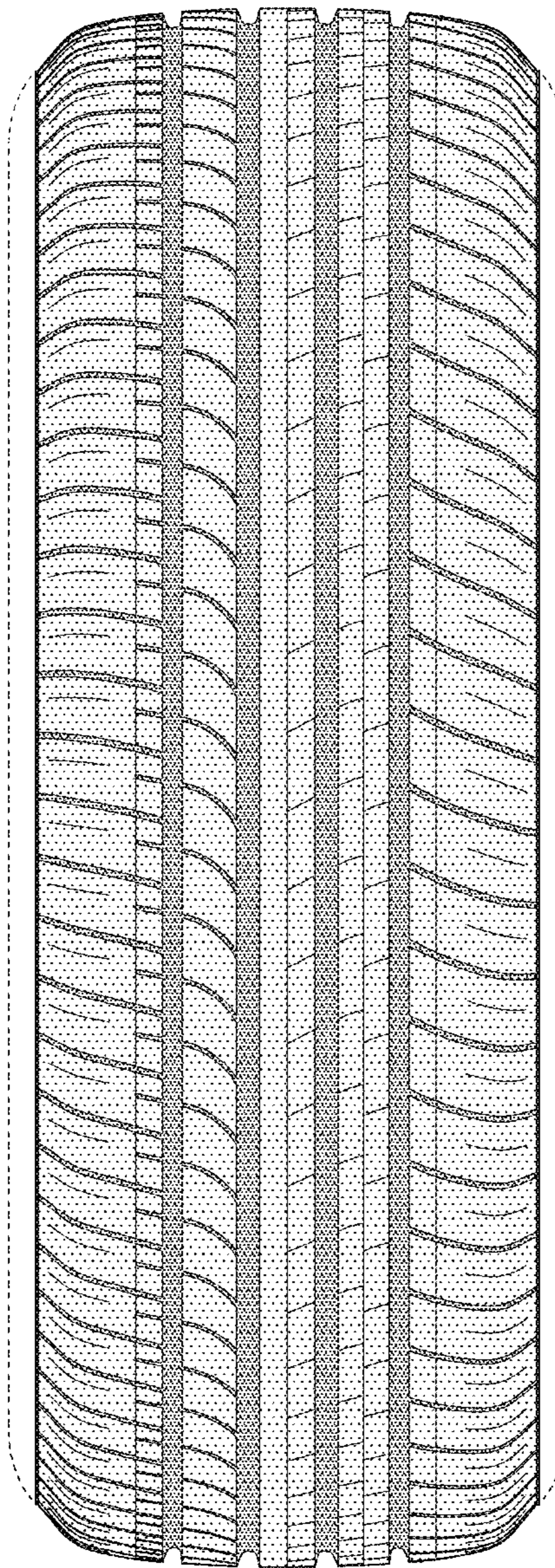

FIG. 3

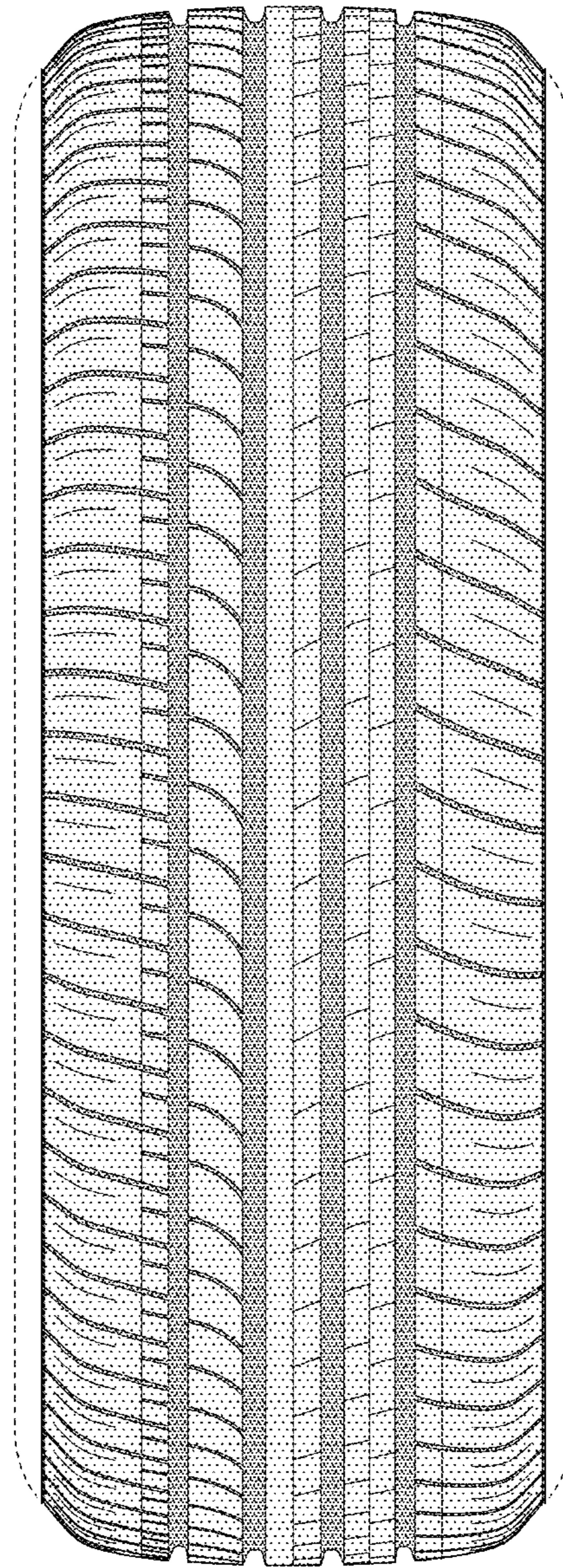

FIG. 4

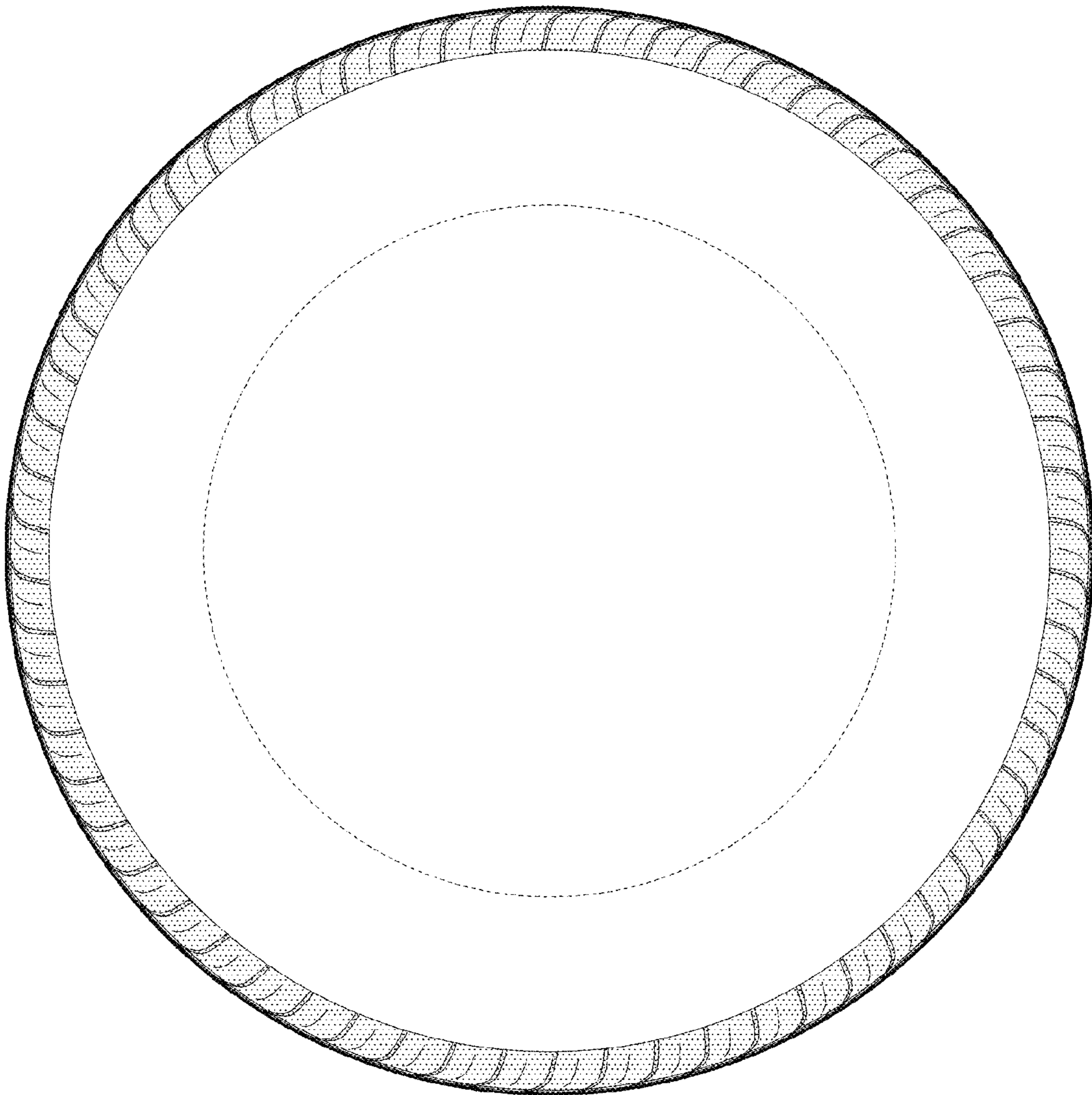

FIG. 5

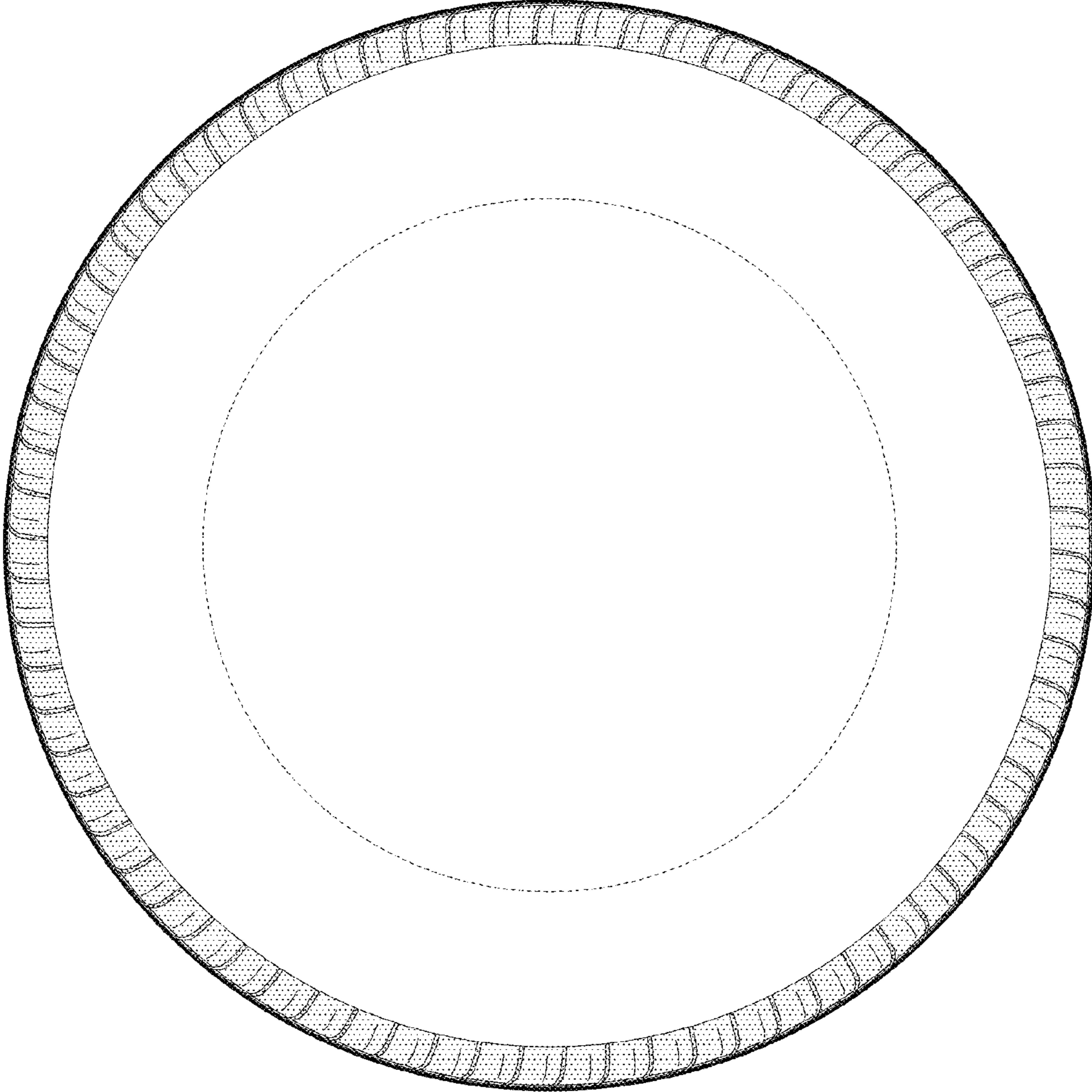

FIG. 6

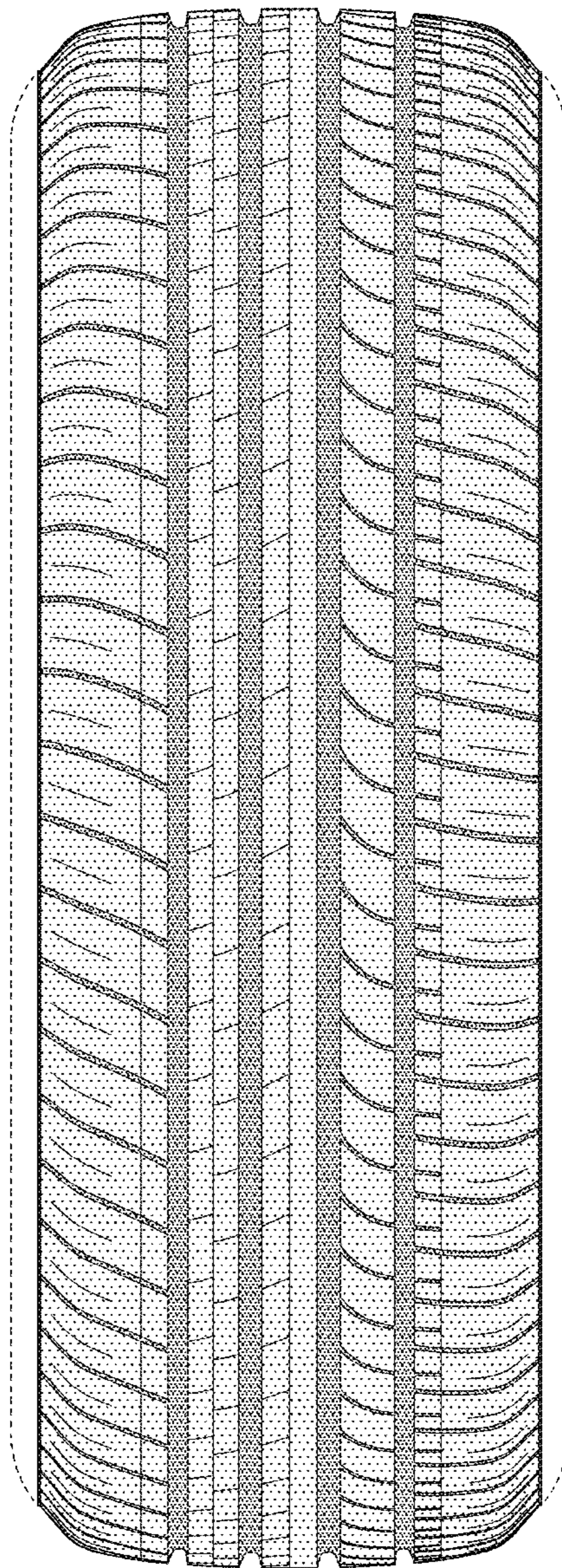

FIG. 7

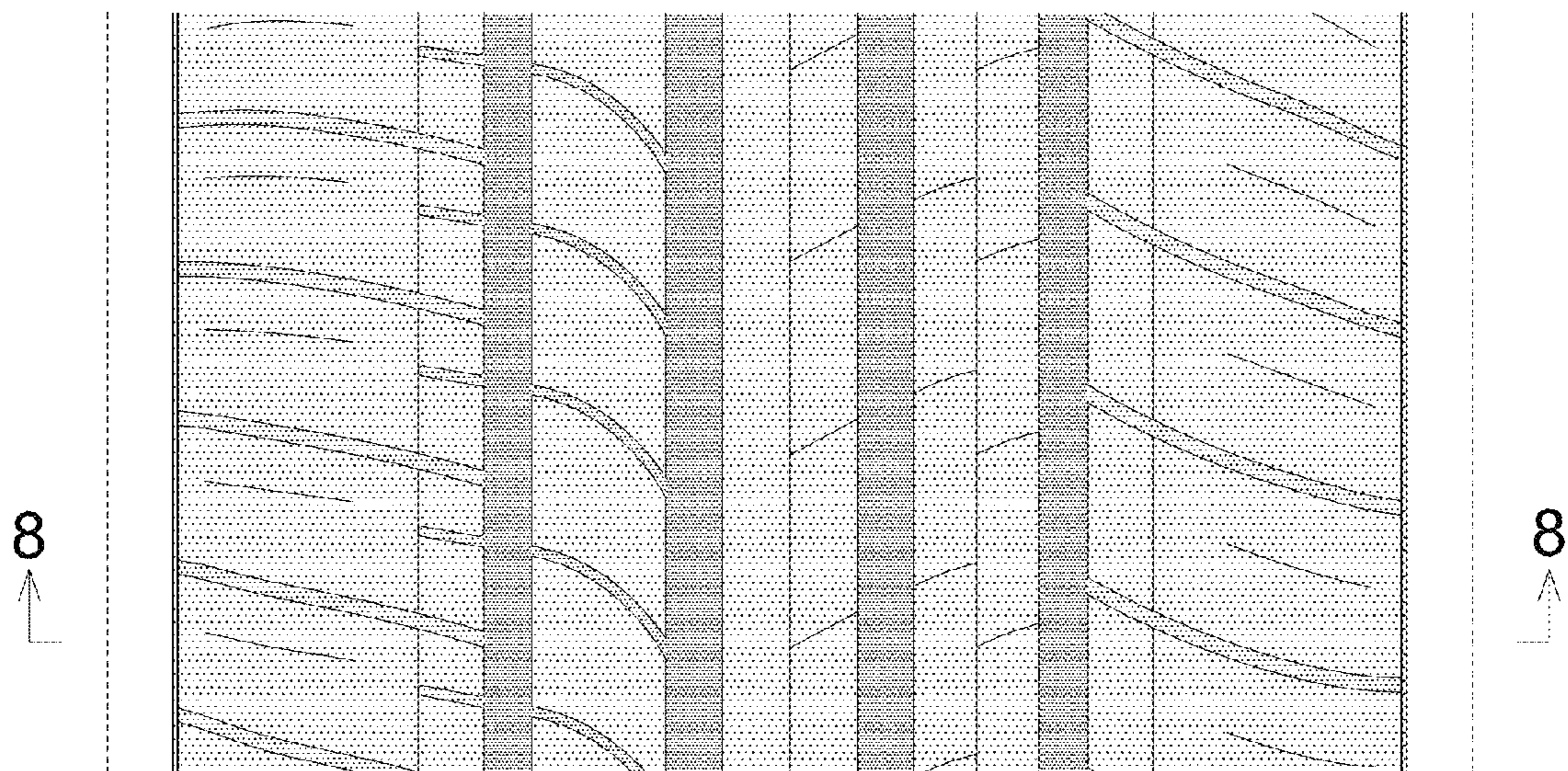

FIG. 8

