



US00D728177S

(12) **United States Design Patent**
Ishibashi et al.

(10) **Patent No.:** **US D728,177 S**
(45) **Date of Patent:** **** Apr. 28, 2015**

(54) **ROLLER SHAFT FOR SUBSTRATE
CLEANING**

(71) Applicant: **Ebara Corporation**, Tokyo (JP)

(72) Inventors: **Tomoatsu Ishibashi**, Tokyo (JP);
Hiroshi Kojima, Tokyo (JP)

(73) Assignee: **Ebara Corporation**, Tokyo (JP)

(**) Term: **14 Years**

(21) Appl. No.: **29/461,043**

(22) Filed: **Jul. 18, 2013**

(30) **Foreign Application Priority Data**

Feb. 1, 2013 (JP) 2013-002015

(51) **LOC (10) Cl.** **08-99**

(52) **U.S. Cl.**
USPC **D32/25; D32/35; D8/399**

(58) **Field of Classification Search**
USPC D32/1, 3, 5, 7, 13, 14, 19, 21, 23, 25,
D32/27, 29, 32, 33, 35; 15/77, 102, 230,
15/230.12, 230.14, 230.16; 134/6;
451/194; D8/349, 354, 356, 363, 379,
D8/382, 383, 385, 386, 387, 394, 397,
D8/399; D15/14, 16, 28, 29, 72, 89, 130,
D15/142; D18/10, 40, 46, 58, 34.2, 34.8
See application file for complete search history.

(56) **References Cited**

U.S. PATENT DOCUMENTS

3,426,365 A * 2/1969 Ament et al. 4/405
D241,074 S * 8/1976 Hasmisch D18/58
D269,852 S * 7/1983 Frieberg D8/399
D293,812 S * 1/1988 Roth D32/25
D357,030 S * 4/1995 McKenna D15/143
5,745,945 A * 5/1998 Manfredi et al. 15/77
6,240,588 B1 * 6/2001 Dickey et al. 15/102
6,254,167 B1 * 7/2001 Goto et al. 15/250.3

D447,755 S * 9/2001 Howard D15/72
6,308,369 B1 10/2001 Garcia et al.
6,330,729 B1 * 12/2001 Brunelli et al. 15/102
6,371,421 B1 * 4/2002 Ma et al. D8/399
6,467,120 B1 * 10/2002 Ziemins et al. 15/102

(Continued)

Primary Examiner — Jeffrey D Asch

Assistant Examiner — Natasha Vujcic

(74) *Attorney, Agent, or Firm* — Pearne & Gordon LLP

(57) **CLAIM**

The ornamental design for a roller shaft for substrate cleaning, as shown and described.

DESCRIPTION

FIG. 1 is a front view of a roller shaft for substrate cleaning showing our new design;
FIG. 2 is a rear view thereof;
FIG. 3 is a plane view thereof;
FIG. 4 is a right side view thereof;
FIG. 5 is an enlarged front view thereof;
FIG. 6 is an enlarged perspective view thereof;
FIG. 7 is another front view, showing the cross-sectional cut line thereof;
FIG. 8 is a cross-section view taken along the line 8-8 of FIG. 1 thereof;
FIG. 9 is an enlarged plane view of portion 9 of FIG. 3 thereof;
FIG. 10 is an enlarged right side view of portion 10 of FIG. 4 thereof; and,
FIG. 11 is a cross-section view taken along the line 11-11 of FIG. 7 thereof.

The internal material revealed by the cross-sectional slice, illustrated in FIGS. 8 and 11, forms no part of the claimed design.

The particular cross-hatching patterns in FIGS. 8 and 11 do not represent any particular materials.

The broken lines in the drawings illustrate portions of the roller shaft for substrate cleaning. the broken lines form no part of the claimed design.

1 Claim, 3 Drawing Sheets

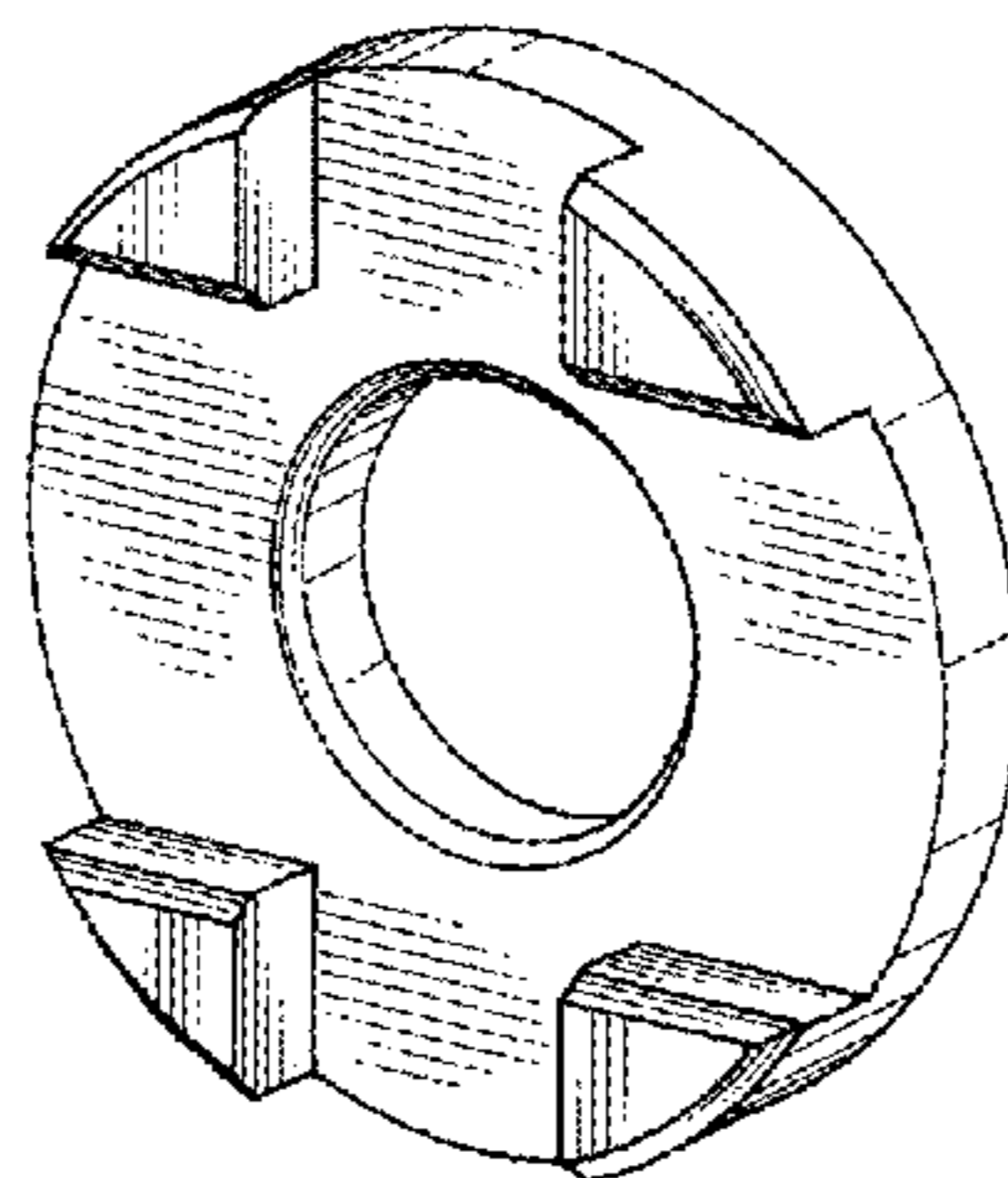

(56)

References Cited

U.S. PATENT DOCUMENTS

D468,190	S *	1/2003	Kennedy et al.	D15/72	8,092,730	B2 *	1/2012	Wargo et al.	15/102
6,502,273	B1 *	1/2003	Mihara et al.	15/102	D658,978	S *	5/2012	Linares	D8/399
6,523,210	B1 *	2/2003	Andros	15/102	8,372,210	B2 *	2/2013	Sin et al.	134/26
6,598,255	B1 *	7/2003	Gohda et al.	15/102	8,496,758	B2 *	7/2013	Idani	15/102
D481,498	S *	10/2003	Pinedo	D32/25	8,533,895	B2 *	9/2013	Benson	15/102
6,802,099	B2 *	10/2004	Murakami et al.	15/102	D707,408	S *	6/2014	Ishibashi	D32/25
D508,750	S *	8/2005	Rashidi	D26/74	D710,062	S *	7/2014	Ishibashi et al.	D32/25
D558,048	S *	12/2007	Perkitny	D9/434	D710,191	S *	8/2014	Yamazaki	D8/399
7,735,177	B1 *	6/2010	Farber et al.	15/102	8,826,778	B1 *	9/2014	Minnick	81/124.2
D622,920	S	8/2010	Bejtlich, III		D718,340	S *	11/2014	Damshak et al.	D15/14
7,955,693	B2 *	6/2011	Drury	15/103.5	2009/0026671	A1 *	1/2009	Kojima et al.	267/121
					2013/0312790	A1 *	11/2013	Ishibashi	134/6
					2014/0295716	A1 *	10/2014	Kojima et al.	439/877

* cited by examiner

FIG. 1

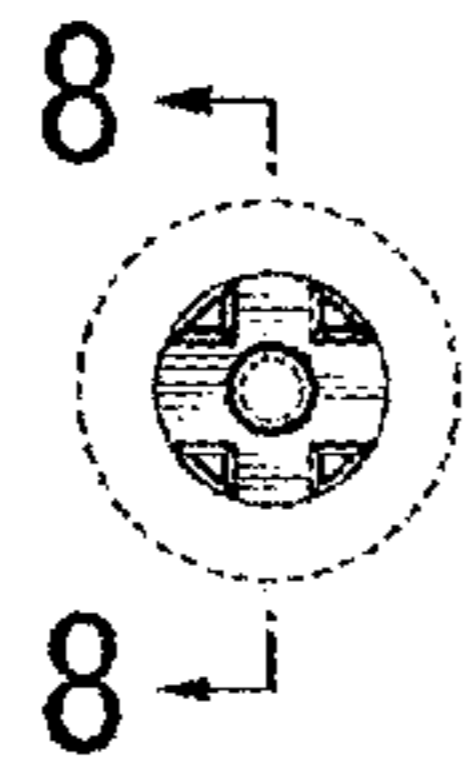

FIG. 2

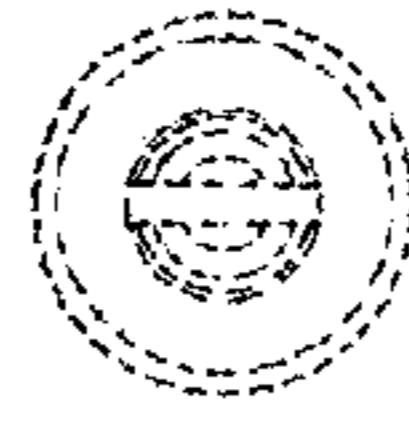

FIG. 3

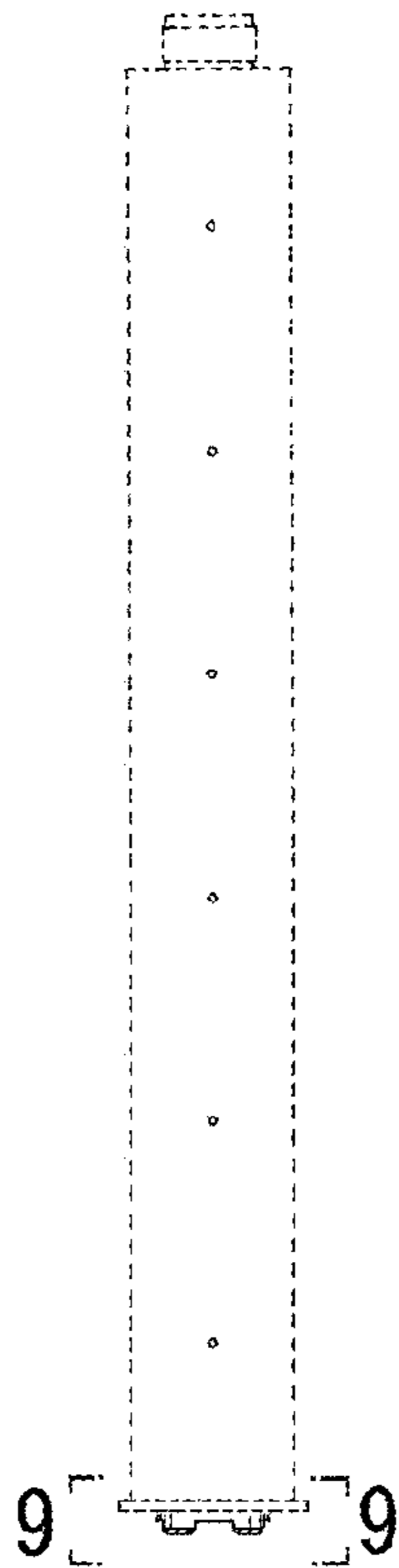

FIG. 4

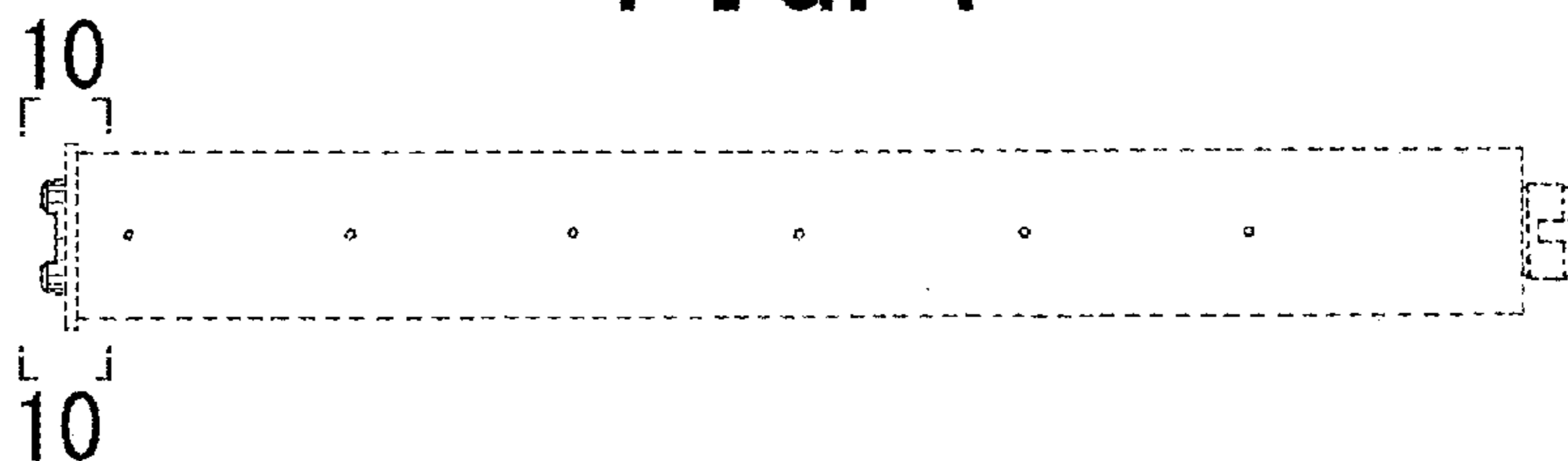

FIG. 5

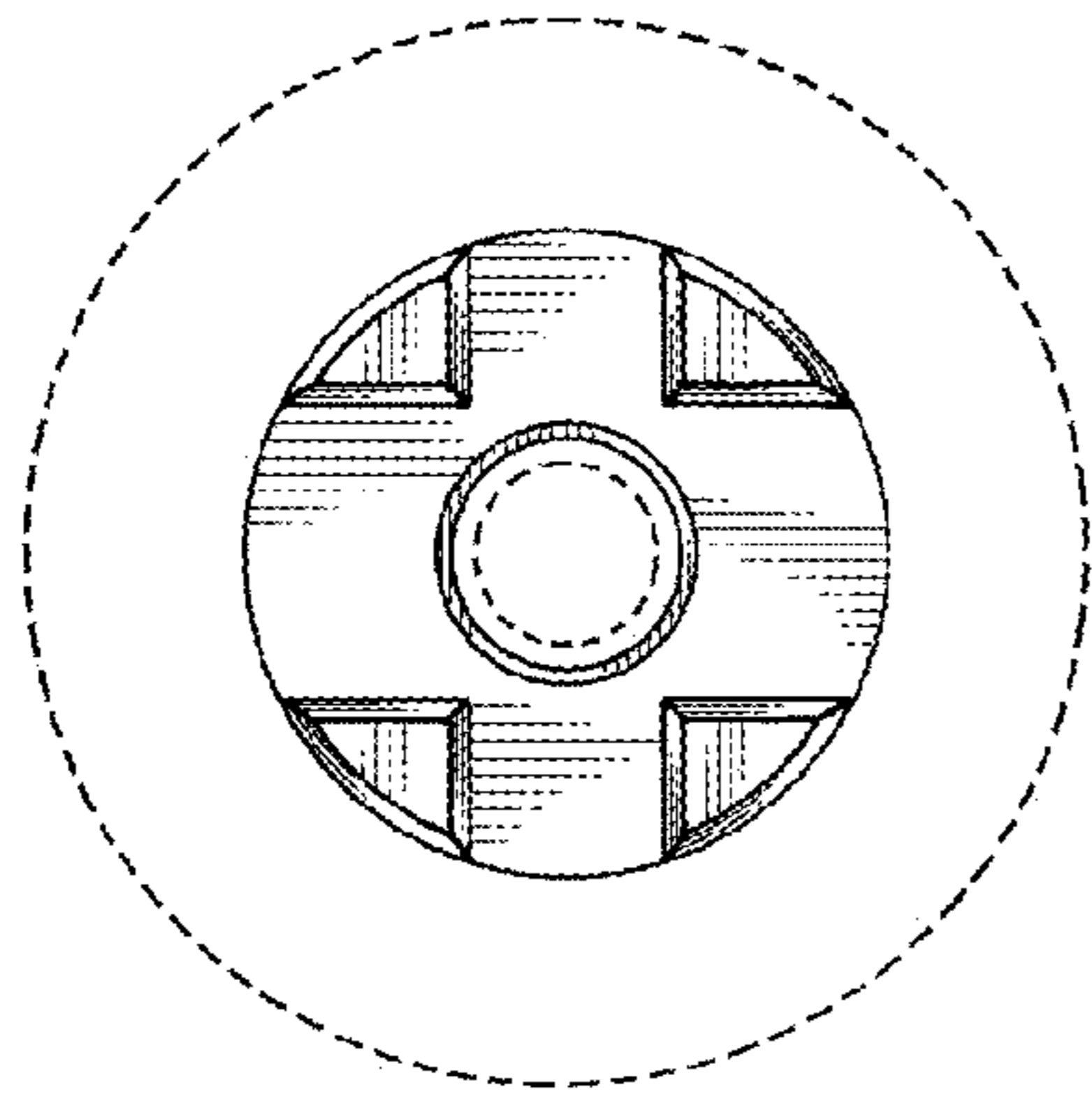

FIG. 6

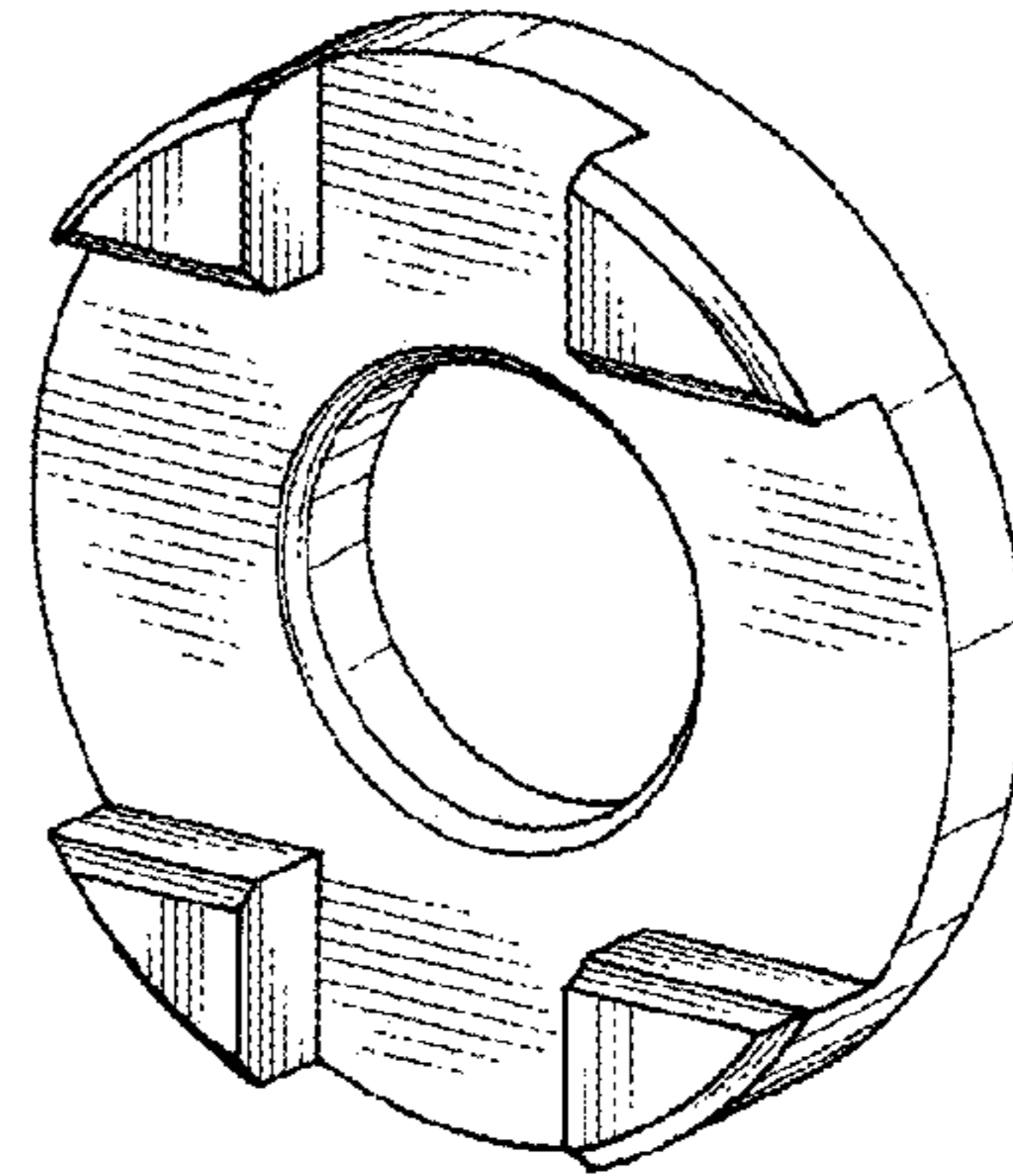

FIG. 7

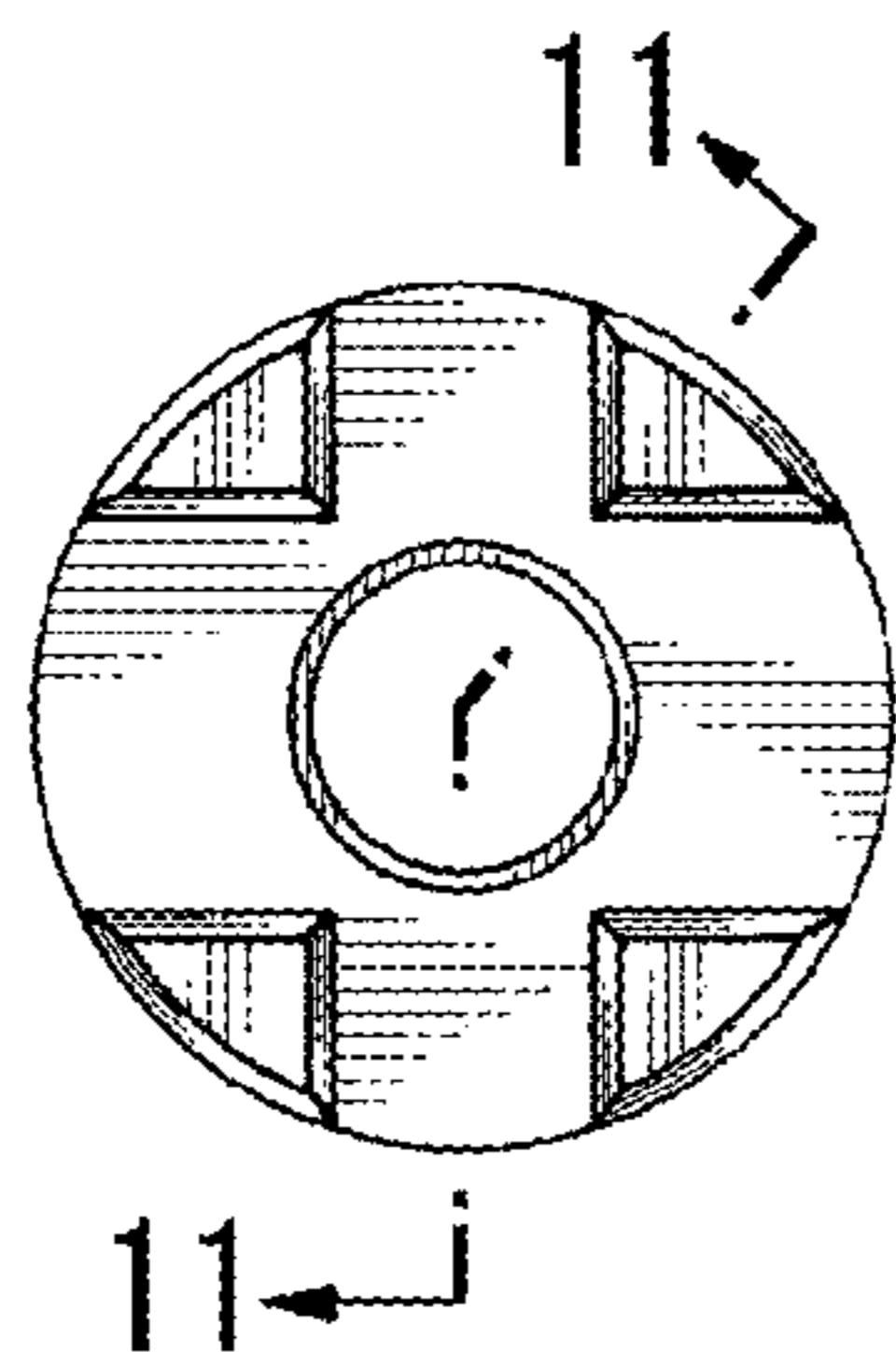

FIG. 8

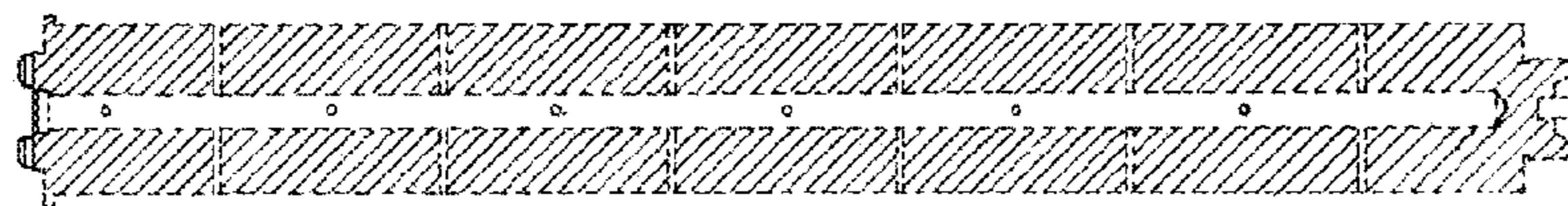

FIG. 9

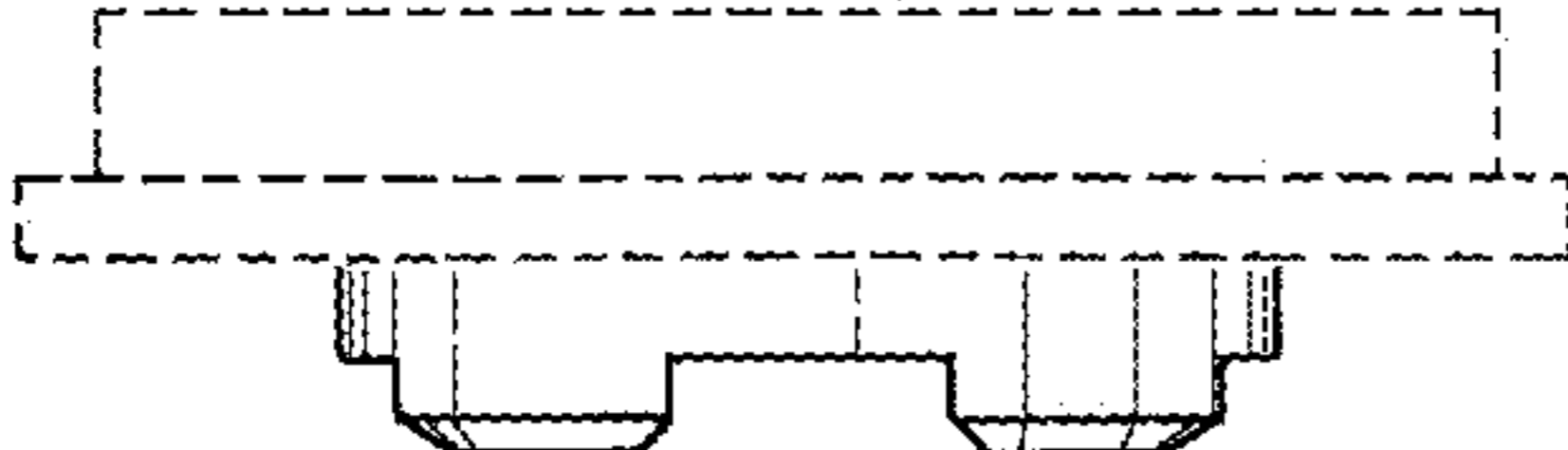

FIG. 10

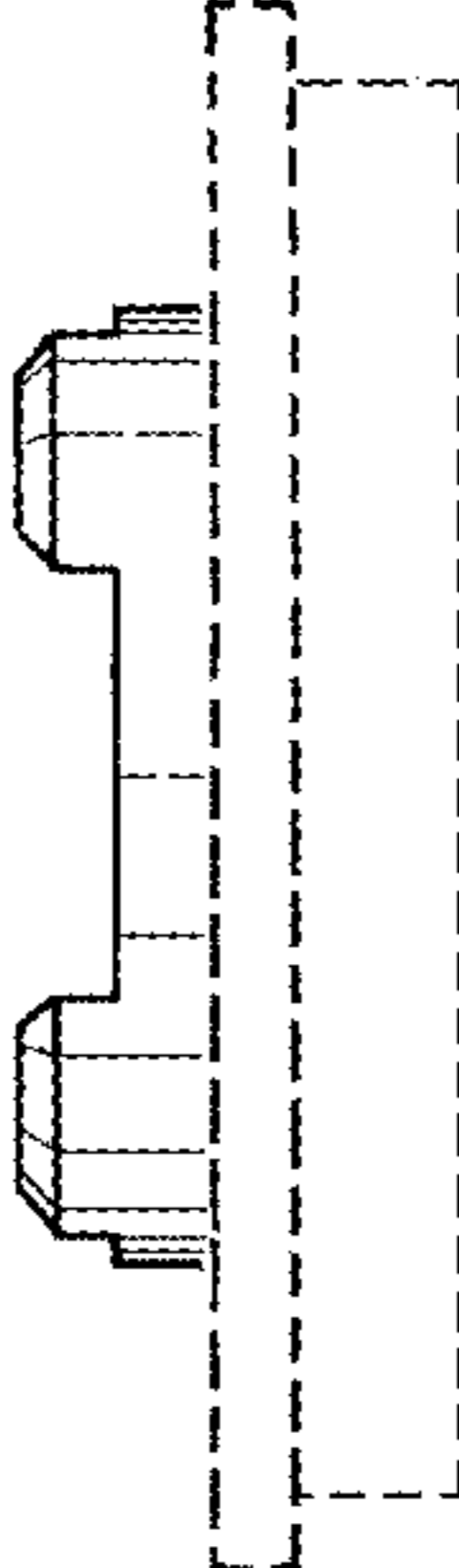

FIG. 11

