



US00D728092S

(12) **United States Design Patent**
Poulton et al.

(10) **Patent No.:** **US D728,092 S**
(45) **Date of Patent:** **** Apr. 28, 2015**

(54) **FAN**
(71) Applicant: **Dyson Technology Limited**, Wiltshire (GB)

2,014,185 A 9/1935 Martin
2,035,733 A 3/1936 Wall
2,071,266 A 2/1937 Schmidt
D103,476 S 3/1937 Weber

(Continued)

(72) Inventors: **Roy Edward Poulton**, Swindon (GB);
Joseph Eric Hodgetts, Bristol (GB);
David Robert Sunderland, Bristol (GB)

FOREIGN PATENT DOCUMENTS

BE 560119 8/1957
CA 1055344 5/1979

(Continued)

(73) Assignee: **Dyson Technology Limited**, Malmesbury, Wiltshire (GB)

OTHER PUBLICATIONS

(**) Term: **14 Years**

Dyson Fan Heater Review (Cozy up to Dyson Fan Heater). vissbiz.com [online] pp. 1 and 2 of 3, Posted Apr. 14, 2014 [retrieved on 2014/09/2014]. Retrieved from Internet: <<http://www.vissbiz.com/dyson-fan-heater-review/cozy-up-to-dyson-fan-heater/>>.*

(Continued)

(21) Appl. No.: **29/480,919**

(22) Filed: **Jan. 30, 2014**

(30) **Foreign Application Priority Data**

Aug. 1, 2013 (EM) 001379531-0005

(51) **LOC (10) Cl.** **23-04**

(52) **U.S. Cl.**
USPC **D23/370; D23/378; D23/342**

(58) **Field of Classification Search**
USPC D23/332-350, 370-379, 411, 499;
D6/309; 415/90, 110, 119, 126, 148,
415/182.1, 183, 207, 208.1, 208.2, 211.2,
415/230; 416/100, 244 R, 246, 247 R;
261/28, 31, 116; 417/84, 177, 198,
417/313, 423.1, 234; 137/338; 392/361,
392/365, 367; 126/110 B, 90 A, 92 A
See application file for complete search history.

Primary Examiner — Susan Bennett Hattan

Assistant Examiner — Marie Fast Horse

(74) *Attorney, Agent, or Firm* — Morrison & Foerster LLP

(57) **CLAIM**

We claim the ornamental design for a fan, as shown and described.

DESCRIPTION

FIG. 1 is a perspective view of a fan showing our new design; FIG. 2 is a front view thereof; FIG. 3 is a rear view thereof; FIG. 4 is a side view thereof; FIG. 5 is a side view of the opposite side of FIG. 4; FIG. 6 is a top view thereof; and, FIG. 7 is a bottom view thereof.

The broken lines in the drawings consisting of even dashes depict portions of the fan that form no part of the claimed design.

(56) **References Cited**

U.S. PATENT DOCUMENTS

284,962 A 9/1883 Huston
1,357,261 A 11/1920 Svoboda
1,767,060 A 6/1930 Ferguson
1,896,869 A 2/1933 Larsh

1 Claim, 6 Drawing Sheets

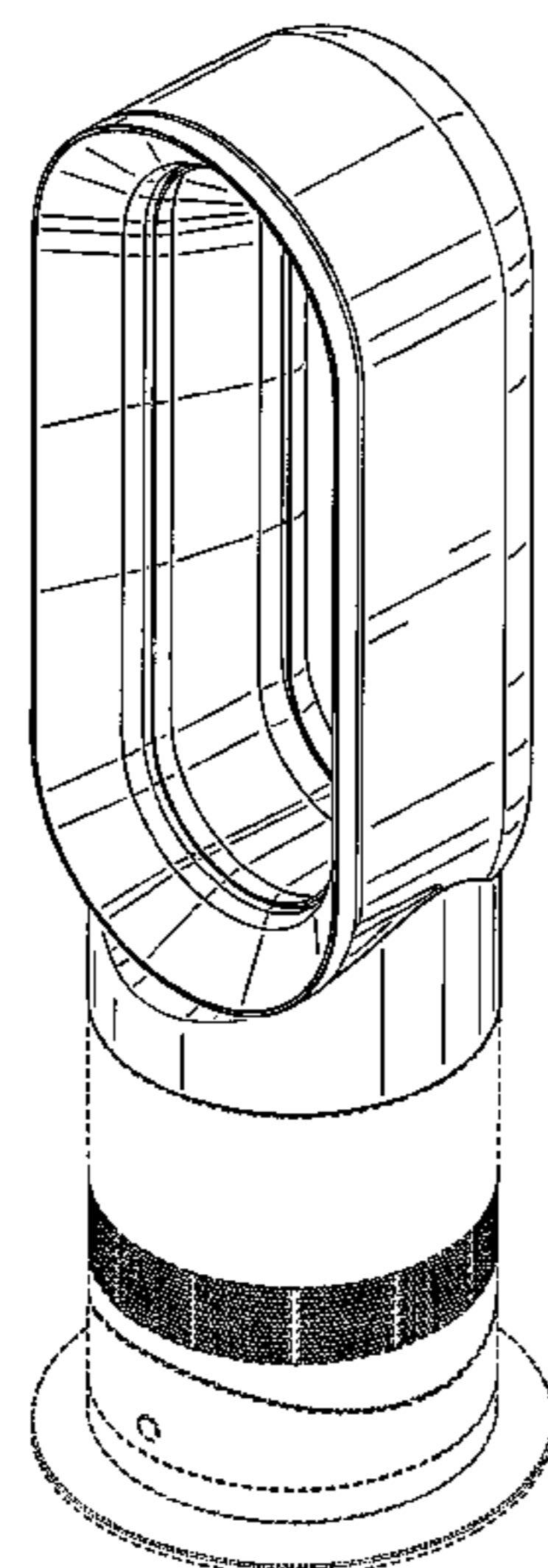

(56)

References Cited

U.S. PATENT DOCUMENTS

2,115,883	A	5/1938	Sher	D346,017	S	4/1994	Lim	
D115,344	S	6/1939	Chapman	5,310,313	A	5/1994	Chen	
2,210,458	A	8/1940	Keilholtz	5,317,815	A	6/1994	Hwang	
2,258,961	A	10/1941	Saathoff	5,338,495	A	8/1994	Steiner et al.	
2,295,502	A	9/1942	Lamb	5,402,938	A	4/1995	Sweeney	
2,336,295	A	12/1943	Reimuller	5,407,324	A	4/1995	Starnes, Jr. et al.	
2,363,839	A	11/1944	Demuth	5,425,902	A	6/1995	Miller et al.	
2,433,795	A	12/1947	Stokes	5,435,489	A	7/1995	Jenkins et al.	
2,473,325	A	6/1949	Aufiero	5,483,616	A	1/1996	Chiu et al.	
2,476,002	A	7/1949	Stalker	5,518,370	A	5/1996	Wang et al.	
2,488,467	A	11/1949	De Lisio	D374,712	S	10/1996	Jane et al.	
2,510,132	A	6/1950	Morrison	5,609,473	A	3/1997	Litvin	
2,544,379	A	3/1951	Davenport	5,645,769	A	7/1997	Tamaru et al.	
2,547,448	A	4/1951	Demuth	5,649,370	A	7/1997	Russo	
2,583,374	A	1/1952	Hoffman	D382,951	S	8/1997	Deines et al.	
2,620,127	A	12/1952	Radcliffe	5,671,321	A	9/1997	Bagnuolo	
2,711,682	A	6/1955	Drechsel	5,677,982	A	10/1997	Levine et al.	
2,765,977	A	10/1956	Morrison	5,735,683	A	4/1998	Muschelknautz	
2,808,198	A	10/1957	Morrison	5,762,034	A	6/1998	Foss	
2,813,673	A	11/1957	Smith	5,762,661	A	6/1998	Kleinberger et al.	
2,830,779	A	4/1958	Wentling	5,783,117	A	7/1998	Byassee et al.	
2,838,229	A	6/1958	Belanger	5,794,306	A	8/1998	Firdaus	
2,922,277	A	1/1960	Bertin	D398,983	S	9/1998	Keller et al.	
2,922,570	A	1/1960	Allen	5,841,080	A	11/1998	Lida et al.	
3,004,403	A	10/1961	Laporte	5,843,344	A	12/1998	Junkel et al.	
3,047,208	A	7/1962	Coanda	5,859,952	A	1/1999	Levine et al.	
3,270,655	A	9/1966	Guirl et al.	5,862,037	A	1/1999	Behl	
D206,973	S	2/1967	De Lisio	5,868,197	A	2/1999	Potier	
3,503,138	A	3/1970	Fuchs et al.	5,881,685	A	3/1999	Foss et al.	
3,518,776	A	7/1970	Wolff et al.	D415,271	S	10/1999	Feer	
3,724,092	A	4/1973	McCleerey	6,015,274	A	1/2000	Bias et al.	
3,729,934	A	5/1973	Denning et al.	D423,663	S	4/2000	Rossmann et al.	
3,743,186	A	7/1973	Mocarski	6,073,881	A	6/2000	Chen	
3,795,367	A	3/1974	Mocarski	D429,808	S	8/2000	Krauss et al.	
3,872,916	A	3/1975	Beck	6,123,618	A	9/2000	Day	
3,875,745	A	4/1975	Franklin	6,155,782	A	12/2000	Hsu	
3,885,891	A	5/1975	Thronndson	D435,899	S	1/2001	Melwani	
3,943,329	A	3/1976	Hlavac	6,254,337	B1	7/2001	Arnold	
4,037,991	A	7/1977	Taylor	6,269,549	B1	8/2001	Carlucci et al.	
4,046,492	A	9/1977	Inglis	6,278,248	B1	8/2001	Hong et al.	
4,061,188	A	12/1977	Beck	6,282,746	B1	9/2001	Schleeter	
4,073,613	A	2/1978	Desty	6,293,121	B1	9/2001	Labrador	
4,090,814	A	5/1978	Teodorescu et al.	6,321,034	B2	11/2001	Jones-Lawlor et al.	
4,113,416	A	9/1978	Kataoka et al.	6,386,845	B1	5/2002	Bedard	
4,136,735	A	1/1979	Beck et al.	6,480,672	B1	11/2002	Rosenzweig et al.	
4,173,995	A	11/1979	Beck	6,599,088	B2	7/2003	Stagg	
4,180,130	A	12/1979	Beck et al.	6,604,694	B1	8/2003	Kordas et al.	
4,184,417	A	1/1980	Chancellor	D483,851	S	12/2003	Fok	
4,184,541	A	1/1980	Beck et al.	D485,895	S	1/2004	Melwani	
4,192,461	A	3/1980	Arborg	D486,903	S	2/2004	Chiang	
4,332,529	A	6/1982	Alperin	6,789,787	B2	9/2004	Stutts	
4,336,017	A	6/1982	Desty	6,791,056	B2	9/2004	VanOtteren et al.	
4,342,204	A	8/1982	Melikian et al.	6,830,433	B2	12/2004	Birdsell et al.	
4,448,354	A	5/1984	Reznick et al.	6,845,971	B2	1/2005	Bachert	
4,568,243	A	2/1986	Schubert et al.	D512,772	S	12/2005	Lee	
4,630,475	A	12/1986	Mizoguchi	D513,067	S	12/2005	Blateri	D23/335
4,643,351	A	2/1987	Fukamachi et al.	7,059,826	B2	6/2006	Lasko	
4,703,152	A	10/1987	Shih-Chin	7,088,913	B1	8/2006	Verhoorn et al.	
4,716,946	A	1/1988	Grigoletto	7,147,336	B1	12/2006	Chou	
4,718,870	A	1/1988	Watts	D539,414	S	3/2007	Russak et al.	D23/411
4,732,539	A	3/1988	Shin-Chin	7,192,258	B2	3/2007	Kuo et al.	
4,734,017	A	3/1988	Levin	7,198,473	B2	4/2007	Stickland et al.	
4,790,133	A	12/1988	Stuart	7,412,781	B2	8/2008	Mattinger et al.	
4,850,804	A	7/1989	Huang	7,478,993	B2	1/2009	Hong et al.	
4,878,620	A	11/1989	Tarleton	7,540,474	B1	6/2009	Huang et al.	
4,893,990	A	1/1990	Tomohiro et al.	D595,835	S	7/2009	Fu	
4,978,281	A	12/1990	Conger	D598,532	S	8/2009	Dyson et al.	D23/370
5,061,405	A	10/1991	Stanek et al.	D602,143	S	10/2009	Gammack et al.	
D325,435	S	4/1992	Coup et al.	D602,144	S	10/2009	Dyson et al.	D23/370
5,110,266	A	5/1992	Toyoshima et al.	D605,748	S	12/2009	Gammack et al.	D23/370
5,168,722	A	12/1992	Brock	7,660,110	B2	2/2010	Vinson et al.	
5,176,856	A	1/1993	Takahashi et al.	7,664,377	B2	2/2010	Liao	
5,188,508	A	2/1993	Scott et al.	D614,280	S	4/2010	Dyson et al.	
D343,231	S	1/1994	Lim	7,731,050	B2	6/2010	Parks et al.	
5,296,769	A	3/1994	Havens et al.	7,775,848	B1	8/2010	Auerbach	
				7,806,388	B2	10/2010	Junkel et al.	
				7,841,045	B2	11/2010	Shaanan et al.	
				D633,997	S	3/2011	Hideharu et al.	D23/370
				D633,999	S	3/2011	Hideharu et al.	D23/370

(56)

References Cited

U.S. PATENT DOCUMENTS

7,931,449 B2	4/2011	Fitton et al.	2009/0214341 A1	8/2009	Craig
D638,114 S	5/2011	Li et al.	2010/0133707 A1	6/2010	Huang
D643,098 S *	8/2011	Wallace et al. D23/342	2010/0150699 A1	6/2010	Nicolas et al.
8,002,520 B2	8/2011	Dawson et al.	2010/0162011 A1	6/2010	Min
D646,373 S	10/2011	Liebson et al.	2010/0171465 A1	7/2010	Seal et al.
8,092,166 B2	1/2012	Nicolas et al.	2010/0225012 A1	9/2010	Fitton et al.
8,113,490 B2	2/2012	Chen	2010/0226749 A1	9/2010	Gammack et al.
8,152,495 B2	4/2012	Boggess, Jr. et al.	2010/0226750 A1	9/2010	Gammack
8,246,317 B2	8/2012	Gammack	2010/0226751 A1	9/2010	Gammack et al.
D669,164 S	10/2012	Hsu	2010/0226752 A1	9/2010	Gammack et al.
8,308,445 B2	11/2012	Gammack et al.	2010/0226753 A1	9/2010	Dyson et al.
D672,023 S *	12/2012	Wallace et al. D23/370	2010/0226754 A1	9/2010	Hutton et al.
D672,024 S	12/2012	Fitton et al.	2010/0226758 A1	9/2010	Cookson et al.
8,348,629 B2	1/2013	Fitton et al.	2010/0226763 A1	9/2010	Gammack et al.
8,356,804 B2	1/2013	Fitton et al.	2010/0226764 A1	9/2010	Gammack et al.
D678,993 S	3/2013	Kung-Hua	2010/0226769 A1	9/2010	Helps
8,403,640 B2	3/2013	Gammack et al.	2010/0226771 A1	9/2010	Crawford et al.
8,408,869 B2	4/2013	Hutton et al.	2010/0226787 A1	9/2010	Gammack et al.
D681,793 S	5/2013	Li	2010/0226797 A1	9/2010	Fitton et al.
D684,249 S	6/2013	Herbst	2010/0226801 A1	9/2010	Gammack
8,454,322 B2	6/2013	Gammack et al.	2010/0254800 A1	10/2010	Fitton et al.
8,469,660 B2	6/2013	Dyson et al.	2011/0058935 A1	3/2011	Gammack et al.
8,529,226 B2	9/2013	Li	2011/0110805 A1	5/2011	Gammack et al.
8,544,826 B2	10/2013	Ediger et al.	2011/0164959 A1	7/2011	Fitton et al.
D700,959 S	3/2014	Sickinger et al.	2011/0223014 A1	9/2011	Crawford et al.
8,684,687 B2	4/2014	Dyson et al.	2011/0223015 A1	9/2011	Gammack et al.
D705,415 S	5/2014	Lo	2011/0236228 A1	9/2011	Fitton et al.
8,721,286 B2	5/2014	Gammack et al.	2012/0031509 A1 *	2/2012	Wallace et al. 137/338
8,721,307 B2	5/2014	Li	2012/0033952 A1 *	2/2012	Wallace et al. 392/367
8,764,412 B2	7/2014	Gammack et al.	2012/0034108 A1 *	2/2012	Wallace et al. 417/313
8,783,663 B2	7/2014	Fitton et al.	2012/0039705 A1	2/2012	Gammack
8,784,071 B2	7/2014	Gammack	2012/0045315 A1	2/2012	Gammack
2002/0104972 A1	8/2002	Guzorek	2012/0045316 A1	2/2012	Gammack
2002/0106547 A1	8/2002	Sugawara et al.	2012/0057959 A1	3/2012	Hodgson et al.
2003/0059307 A1	3/2003	Moreno et al.	2012/0082561 A1	4/2012	Gammack et al.
2003/0164367 A1	9/2003	Bucher et al.	2012/0093629 A1	4/2012	Fitton et al.
2003/0171093 A1	9/2003	Gumucio Del Pozo	2012/0093630 A1	4/2012	Fitton et al.
2003/0190183 A1	10/2003	Hsing	2012/0114513 A1	5/2012	Simmonds et al.
2004/0022631 A1	2/2004	Birdsell et al.	2012/0230658 A1 *	9/2012	Fitton et al. 392/361
2004/0049842 A1	3/2004	Prehodka	2012/0308375 A1	12/2012	Gammack
2004/0106370 A1	6/2004	Honda et al.	2013/0011252 A1	1/2013	Crawford et al.
2004/0149881 A1	8/2004	Allen	2013/0026664 A1	1/2013	Staniforth et al.
2005/0031448 A1	2/2005	Lasko et al.	2013/0028763 A1	1/2013	Staniforth et al.
2005/0053465 A1	3/2005	Roach et al.	2013/0028766 A1	1/2013	Staniforth et al.
2005/0069407 A1	3/2005	Winkler et al.	2013/0129490 A1	5/2013	Dos Reis et al.
2005/0128698 A1	6/2005	Huang	2013/0142676 A1	6/2013	Zou
2005/0163670 A1	7/2005	Alleyne et al.	2013/0161842 A1	6/2013	Fitton et al.
2005/0173997 A1	8/2005	Schmid et al.	2013/0199372 A1	8/2013	Nock et al.
2005/0281672 A1	12/2005	Parker et al.	2013/0234346 A1	9/2013	Staniforth et al.
2006/0172682 A1	8/2006	Orr et al.	2013/0234347 A1	9/2013	Staniforth et al.
2006/0199515 A1	9/2006	Lasko et al.	2013/0249122 A1	9/2013	Staniforth et al.
2006/0263073 A1	11/2006	Clarke et al.	2013/0249124 A1	9/2013	Staniforth et al.
2006/0279927 A1	12/2006	Strohm	2013/0249126 A1	9/2013	Staniforth et al.
2007/0035189 A1	2/2007	Matsumoto	2013/0272858 A1	10/2013	Stickney et al.
2007/0041857 A1	2/2007	Fleig	2013/0280051 A1	10/2013	Nicolas et al.
2007/0065280 A1	3/2007	Fok	2013/0280061 A1	10/2013	Stickney
2007/0166160 A1	7/2007	Russak et al.	2013/0280096 A1	10/2013	Gammack et al.
2007/0176502 A1	8/2007	Kasai et al.	2013/0309065 A1	11/2013	Johnson et al.
2007/0224044 A1	9/2007	Hong et al.	2013/0309080 A1	11/2013	Johnson et al.
2007/0237500 A1	10/2007	Wang	2013/0323100 A1	12/2013	Poulton et al.
2007/0269323 A1	11/2007	Zhou et al.	2013/0336771 A1	12/2013	Dyson et al.
2008/0020698 A1	1/2008	Spaggiari	2014/0017069 A1	1/2014	Peters
2008/0124060 A1	5/2008	Gao	2014/0077398 A1	3/2014	Staniforth et al.
2008/0152482 A1	6/2008	Patel	2014/0079566 A1	3/2014	Gammack et al.
2008/0166224 A1	7/2008	Giffin	2014/0084492 A1 *	3/2014	Staniforth et al. 261/31
2008/0286130 A1	11/2008	Purvines	2014/0210114 A1	7/2014	Staniforth et al.
2008/0314250 A1	12/2008	Cowie et al.	2014/0210115 A1	7/2014	Staniforth et al.
2009/0026850 A1	1/2009	Fu	2014/0255173 A1	9/2014	Poulton et al.
2009/0032130 A1	2/2009	Dumas et al.	2014/0255217 A1	9/2014	Li
2009/0039805 A1	2/2009	Tang			
2009/0060710 A1	3/2009	Gammack et al.			
2009/0060711 A1	3/2009	Gammack et al.			
2009/0078120 A1	3/2009	Kummer et al.			
2009/0120925 A1	5/2009	Lasko			
2009/0191054 A1	7/2009	Winkler			

FOREIGN PATENT DOCUMENTS

CA	2155482	9/1996
CH	346643	5/1960
CN	2085866	10/1991
CN	2111392	7/1992
CN	2549372	5/2003
CN	1437300	8/2003
CN	2650005	10/2004

(56)

References Cited

FOREIGN PATENT DOCUMENTS			FR		
			FR	2 375 471	7/1978
			FR	2 534 983	4/1984
			FR	2 640 857	6/1990
			FR	2 658 593	8/1991
			FR	2794195	12/2000
			FR	2 874 409	2/2006
			FR	2 906 980	4/2008
			FR	2928706	9/2009
			GB	22235	0/1914
			GB	383498	11/1932
			GB	593828	10/1947
			GB	601222	4/1948
			GB	633273	12/1949
			GB	641622	8/1950
			GB	661747	11/1951
			GB	863124	3/1961
			GB	1067956	5/1967
			GB	1 262 131	2/1972
			GB	1 265 341	3/1972
			GB	1 278 606	6/1972
			GB	1 304 560	1/1973
			GB	1 403 188	8/1975
			GB	1 434 226	5/1976
			GB	1 501 473	2/1978
			GB	2 094 400	9/1982
			GB	2 107 787	5/1983
			GB	2 111 125	6/1983
			GB	2 178 256	2/1987
			GB	2 185 531	7/1987
			GB	2 185 533	7/1987
			GB	2 218 196	11/1989
			GB	2 236 804	4/1991
			GB	2 240 268	7/1991
			GB	2 242 935	10/1991
			GB	2 285 504	7/1995
			GB	2 289 087	11/1995
			GB	2383277	6/2003
			GB	2 428 569	2/2007
			GB	2 452 593	3/2009
			GB	2452490	3/2009
			GB	2463698	3/2010
			GB	2464736	4/2010
			GB	2466058	6/2010
			GB	2468312	9/2010
			GB	2468313	9/2010
			GB	2468315	9/2010
			GB	2468317	9/2010
			GB	2468319	9/2010
			GB	2468320	9/2010
			GB	2468323	9/2010
			GB	2468328	9/2010
			GB	2468329	9/2010
			GB	2468331	9/2010
			GB	2468369	9/2010
			GB	2468498	9/2010
			GB	2473037	3/2011
			GB	2479760	10/2011
			GB	2482547	2/2012
			GB	2484671	4/2012
			GB	2484695	4/2012
			GB	2484761	4/2012
			GB	2493231	1/2013
			GB	2493505	2/2013
			GB	2493507	2/2013
			GB	2500011	9/2013
			JP	31-13055	8/1956
			JP	35-4369	3/1960
			JP	39-7297	3/1964
			JP	46-7230	12/1971
			JP	47-21718	10/1972
			JP	49-43764	4/1974
			JP	49-150403	12/1974
			JP	51-7258	1/1976
			JP	52-121045	9/1977
			JP	53-60100	5/1978
			JP	56-167897	12/1981
			JP	57-71000	5/1982
			JP	57-157097	9/1982
			JP	61-31830	2/1986
CN	2713643	7/2005			
CN	1680727	10/2005			
CN	2833197	11/2006			
CN	201011346	1/2008			
CN	201147215	11/2008			
CN	201180678	1/2009			
CN	201221477	4/2009			
CN	101424279	5/2009			
CN	101451754	6/2009			
CN	201281416	7/2009			
CN	201349269	11/2009			
CN	101684828	3/2010			
CN	201486901	5/2010			
CN	101749288	6/2010			
CN	201502549	6/2010			
CN	201507461	6/2010			
CN	101825096	9/2010			
CN	101825101	9/2010			
CN	101825102	9/2010			
CN	101825103	9/2010			
CN	101825104	9/2010			
CN	201568337	9/2010			
CN	101858355	10/2010			
CN	101936310	1/2011			
CN	201696365	1/2011			
CN	201696366	1/2011			
CN	201739199	2/2011			
CN	101984299	3/2011			
CN	101985948	3/2011			
CN	201763705	3/2011			
CN	201763706	3/2011			
CN	201770513	3/2011			
CN	201771875	3/2011			
CN	201779080	3/2011			
CN	201786777	4/2011			
CN	201786778	4/2011			
CN	201802648	4/2011			
CN	301539668	5/2011			
CN	102095236	6/2011			
CN	201858204	6/2011			
CN	201874898	6/2011			
CN	201874901	6/2011			
CN	201917047	8/2011			
CN	102251973	11/2011			
CN	102287357	12/2011			
CN	102367813	3/2012			
CN	202267207	6/2012			
CN	301949285	6/2012			
CN	202431623	9/2012			
DE	1 291 090	3/1969			
DE	24 51 557	5/1976			
DE	27 48 724	5/1978			
DE	3644567	7/1988			
DE	195 10 397	9/1996			
DE	197 12 228	10/1998			
DE	100 00 400	3/2001			
DE	10041805	6/2002			
DE	10 2009 007 037	8/2010			
EP	0 044 494	1/1982			
EP	0 186 581	7/1986			
EP	0 459 812	12/1991			
EP	0 784 947	7/1997			
EP	1 094 224	4/2001			
EP	1 138 954	10/2001			
EP	1357296	10/2003			
EP	1 779 745	5/2007			
EP	1 939 456	7/2008			
EP	1 980 432	10/2008			
EP	2 000 675	12/2008			
EP	2191142	6/2010			
EP	2 414 738	2/2012			
EP	2 578 889	4/2013			
FR	1033034	7/1953			
FR	1119439	6/1956			
FR	1.387334	1/1965			

(56)

References Cited

FOREIGN PATENT DOCUMENTS			OTHER PUBLICATIONS		
JP	61-116093	6/1986	KR	10-2005-0102317	10/2005
JP	61-280787	12/1986	KR	2007-0007997	1/2007
JP	62-98099	5/1987	KR	20-0448319	3/2010
JP	62-223494	10/1987	KR	10-2010-0055611	5/2010
JP	63-36794	3/1988	KR	10-0985378	9/2010
JP	63-179198	7/1988	TW	517825	1/2003
JP	63-198933	12/1988	TW	589932	6/2004
JP	63-306340	12/1988	TW	M394383	12/2010
JP	64-21300	2/1989	TW	M399207	3/2011
JP	64-58955	3/1989	TW	M407299	7/2011
JP	64-83884	3/1989	WO	WO-90/13478	11/1990
JP	1-138399	5/1989	WO	WO-95/06822	3/1995
JP	1-224598	9/1989	WO	WO-02/073096	9/2002
JP	2-146294	6/1990	WO	WO-03/058795	7/2003
JP	2-218890	8/1990	WO	WO-03/069931	8/2003
JP	2-248690	10/1990	WO	WO-2005/050026	6/2005
JP	3-52515	5/1991	WO	WO-2005/057091	6/2005
JP	3-267598	11/1991	WO	WO-2006/008021	1/2006
JP	3-286775	12/1991	WO	WO-2006/012526	2/2006
JP	4-43895	2/1992	WO	WO-2007/024955	3/2007
JP	4-366330	12/1992	WO	WO-2007/048205	5/2007
JP	5-99386	4/1993	WO	WO-2008/014641	2/2008
JP	5-157093	6/1993	WO	WO-2008/024569	2/2008
JP	5-164089	6/1993	WO	WO-2008/139491	11/2008
JP	5-263786	10/1993	WO	WO-2009/030879	3/2009
JP	6-74190	3/1994	WO	WO-2009/030881	3/2009
JP	6-86898	3/1994	WO	WO-2010/100449	9/2010
JP	6-147188	5/1994	WO	WO-2010/100451	9/2010
JP	6-257591	9/1994	WO	WO-2010/100452	9/2010
JP	6-280800	10/1994	WO	WO-2010/100453	9/2010
JP	6-336113	12/1994	WO	WO-2010/100462	9/2010
JP	7-190443	7/1995	WO	WO-2011/050041	4/2011
JP	8-21400	1/1996	WO	WO-2011/147318	12/2011
JP	8-72525	3/1996	WO	WO-2012/006882	1/2012
JP	8-313019	11/1996	WO	WO-2012/033517	3/2012
JP	9-100800	4/1997	WO	WO-2012/052737	4/2012
JP	9-178083	7/1997	WO	WO-2013/014419	1/2013
JP	9-287600	11/1997	WO	WO-2013/132218	9/2013
JP	11-502586	3/1999			
JP	11-227866	8/1999			
JP	2000-55419	2/2000			
JP	2000-116179	4/2000			
JP	2000-201723	7/2000			
JP	2001-17358	1/2001			
JP	2002-21797	1/2002			
JP	2002-138829	5/2002			
JP	2002-213388	7/2002			
JP	2003-4265	1/2003			
JP	2003-329273	11/2003			
JP	2004-8275	1/2004			
JP	2004-208935	7/2004			
JP	2004-216221	8/2004			
JP	2005-201507	7/2005			
JP	2005-307985	11/2005			
JP	2006-89096	4/2006			
JP	2006-189221	7/2006			
JP	3127331	11/2006			
JP	2007-138763	6/2007			
JP	2007-138789	6/2007			
JP	2008-39316	2/2008			
JP	2008-100204	5/2008			
JP	3144127	8/2008			
JP	3146538	10/2008			
JP	2008-294243	12/2008			
JP	2009-44568	2/2009			
JP	2009-62986	3/2009			
JP	D1371413	10/2009			
JP	2009-275925	11/2009			
JP	D1376284	12/2009			
JP	2010-46411	3/2010			
JP	2010-131259	6/2010			
JP	2010-203760	9/2010			
JP	2010-203764	9/2010			
JP	2012-31806	2/2012			
KR	1999-002660	1/1999			

Pisenic Bladeless Fan (16 Inches with Remote Control, Bladeless Fan Air Conditioner 110v, Air Multiplier Table Fans, Green). Amazon.com [online PDF] 4 pages. Posted May 11, 2013 [retrieved on Sep. 2, 2014]. Retrieved from Internet: <http://www.amazon.com/Pisenic-Bladeless-Control-Conditioner-Multiplier/dp/B007VCI78M/ref=pd_rhf_se_p_imgnr_3/>.*

Dos Reis et al., U.S. Office Action mailed Sep. 23, 2014, directed to U.S. Appl. No. 29/466,240; 9 pages.

Dos Reis et al., U.S. Office Action mailed Sep. 24, 2014, directed to U.S. Appl. No. 29/466,229; 9 pages.

Dos Reis et al., U.S. Office Action mailed Sep. 19, 2014, directed to U.S. Appl. No. 29/466,190; 9 pages.

Mcperson et al., U.S. Office Action mailed Sep. 19, 2014, directed to U.S. Appl. No. 29/466,094; 8 pages.

Mcperson et al., U.S. Office Action mailed Sep. 19, 2014, directed to U.S. Appl. No. 29/466,241; 8 pages.

Mcperson et al., U.S. Office Action mailed Sep. 19, 2014, directed to U.S. Appl. No. 29/466,253; 7 pages.

Dyson et al., U.S. Office Action mailed Sep. 12, 2014, directed to U.S. Appl. No. 29/480,896; 10 pages.

Dyson et al., U.S. Office Action mailed Sep. 12, 2014, directed to U.S. Appl. No. 29/480,915; 9 pages.

Deniss. (Sep. 9, 2010) "iFan, The Chinese Clone of the Dyson Air Multiplier," located at <<http://chinitech.com/en/chinese-clones/ifan-le-clone-chinois-du-dyson-air-multiplier>> visited on Aug. 29, 2014. (6 pages).

Amee. (Mar. 29, 2012) "Breeze Right Bladeless Fan Up to 41% Off," located at <<http://madamedeals.com/breeze-right-bladeless-fan-up-to-41-off/>> visited on Sep. 3, 2014. (2 pages).

Questel. (Jun. 11, 2014) "Designs-Questel" located at <<http://sobjprd.questel.fr/export/QPTUJ214/pdf2/19f053ea-a60f-4c58-9232-c458147a9adf-224304.pdf/>> visited on Sep. 4, 2014. (67 pages).

(56)

References Cited

OTHER PUBLICATIONS

Lee. (Nov. 15, 2011) "Fan with No Blades EBH107," located at <http://www.weiku.com/products/12806615/Fan_With_No_Blades_EBH107.html> visited on Nov. 4, 2014. (4 pages).

Reba, I. (1966). "Applications of the Coanda Effect," *Scientific American* 214:84-92.

Third Party Submission Under 37 CFR 1.99 filed Jun. 2, 2011, directed to U.S. Appl. No. 12/203,698; 3 pages.

Gammack et al., U.S. Office Action mailed Dec. 9, 2010, directed to U.S. Appl. No. 12/203,698; 10 pages.

Gammack et al., U.S. Office Action mailed Jun. 21, 2011, directed to U.S. Appl. No. 12/203,698; 11 pages.

Gammack et al., U.S. Office Action mailed Sep. 17, 2012, directed to U.S. Appl. No. 13/114,707; 12 pages.

Gammack et al., U.S. Office Action mailed Dec. 10, 2010, directed to U.S. Appl. No. 12/230,613; 12 pages.

Gammack et al., U.S. Office Action mailed May 13, 2011, directed to U.S. Appl. No. 12/230,613; 13 pages.

Gammack et al., U.S. Office Action mailed Sep. 7, 2011, directed to U.S. Appl. No. 12/230,613; 15 pages.

Gammack et al., U.S. Office Action mailed Jun. 8, 2012, directed to U.S. Appl. No. 12/230,613; 15 pages.

Gammack et al., U.S. Office Action mailed Aug. 20, 2012, directed to U.S. Appl. No. 12/945,558; 15 pages.

Gammack et al., U.S. Office Action mailed Feb. 28, 2013, directed to U.S. Appl. No. 12/945,558; 16 pages.

Gammack et al., U.S. Office Action mailed Jun. 12, 2013, directed to U.S. Appl. No. 12/945,558; 20 pages.

Fitton et al., U.S. Office Action mailed Nov. 30, 2010 directed to U.S. Appl. No. 12/560,232; 9 pages.

Nicolas et al., U.S. Office Action mailed Mar. 7, 2011, directed to U.S. Appl. No. 12/622,844; 10 pages.

Nicolas et al., U.S. Office Action mailed Sep. 8, 2011, directed to U.S. Appl. No. 12/622,844; 11 pages.

Helps et al., U.S. Office Action mailed Feb. 15, 2013, directed to U.S. Appl. No. 12/716,694; 12 pages.

Gammack et al., U.S. Office Action mailed Dec. 9, 2010, directed to U.S. Appl. No. 12/716,781; 17 pages.

Gammack et al., U.S. Office Action mailed Jun. 24, 2011, directed to U.S. Appl. No. 12/716,781; 19 pages.

Gammack et al., U.S. Office Action mailed May 29, 2013, directed to U.S. Appl. No. 13/588,666; 11 pages.

Gammack et al., U.S. Office Action mailed Sep. 27, 2013, directed to U.S. Appl. No. 13/588,666; 10 pages.

Gammack et al., U.S. Office Action mailed Mar. 14, 2013, directed to U.S. Appl. No. 12/716,740; 15 pages.

Gammack et al., U.S. Office Action mailed Sep. 6, 2013, directed to U.S. Appl. No. 12/716,740; 15 pages.

Gammack et al., U.S. Office Action mailed Apr. 24, 2014, directed to U.S. Appl. No. 12/716,740; 16 pages.

Li et al., U.S. Office Action mailed Oct. 25, 2013, directed to U.S. Appl. No. 13/686,480; 17 pages.

Fitton et al., U.S. Office Action mailed Jun. 13, 2014, directed to U.S. Appl. No. 13/274,998; 11 pages.

Fitton et al., U.S. Office Action mailed Jun. 13, 2014, directed to U.S. Appl. No. 13/275,034; 10 pages.

Gammack et al., U.S. Office Action mailed Feb. 14, 2013, directed to U.S. Appl. No. 12/716,515; 21 pages.

Gammack et al., U.S. Office Action mailed Aug. 19, 2013, directed to U.S. Appl. No. 12/716,515; 20 pages.

Gammack et al., U.S. Office Action mailed Feb. 10, 2014, directed to U.S. Appl. No. 12/716,515; 21 pages.

Fitton et al., U.S. Office Action mailed Mar. 30, 2012, directed to U.S. Appl. No. 12/716,707; 7 pages.

Fitton et al., U.S. Office Action mailed Dec. 31, 2013, directed to U.S. Appl. No. 13/718,693; 8 pages.

Staniforth et al., U.S. Office Action mailed Sep. 18, 2014, directed to U.S. Appl. No. 13/559,142; 18 pages.

Gammack et al., U.S. Office Action mailed Oct. 18, 2012, directed to U.S. Appl. No. 12/917,247; 11 pages.

Gammack et al., U.S. Office Action mailed Sep. 3, 2014, directed to U.S. Appl. No. 13/861,891; 7 pages.

Wallace et al., U.S. Office Action mailed Jun. 7, 2013, directed to U.S. Appl. No. 13/192,223; 30 pages.

Wallace et al., U.S. Office Action mailed Oct. 23, 2013, directed to U.S. Appl. No. 13/192,223; 18 pages.

Gammack et al., U.S. Office Action mailed Apr. 12, 2011, directed to U.S. Appl. No. 12/716,749; 8 pages.

Gammack et al., U.S. Office Action mailed Sep. 1, 2011, directed to U.S. Appl. No. 12/716,749; 9 pages.

Gammack et al., U.S. Office Action mailed Jun. 25, 2012, directed to U.S. Appl. No. 12/716,749; 11 pages.

Gammack et al., U.S. Office Action mailed May 24, 2011, directed to U.S. Appl. No. 12/716,613; 9 pages.

Fitton et al., U.S. Office Action mailed Mar. 8, 2011, directed to U.S. Appl. No. 12/716,780; 12 pages.

Fitton et al., U.S. Office Action mailed Sep. 6, 2011, directed to U.S. Appl. No. 12/716,780; 16 pages.

* cited by examiner

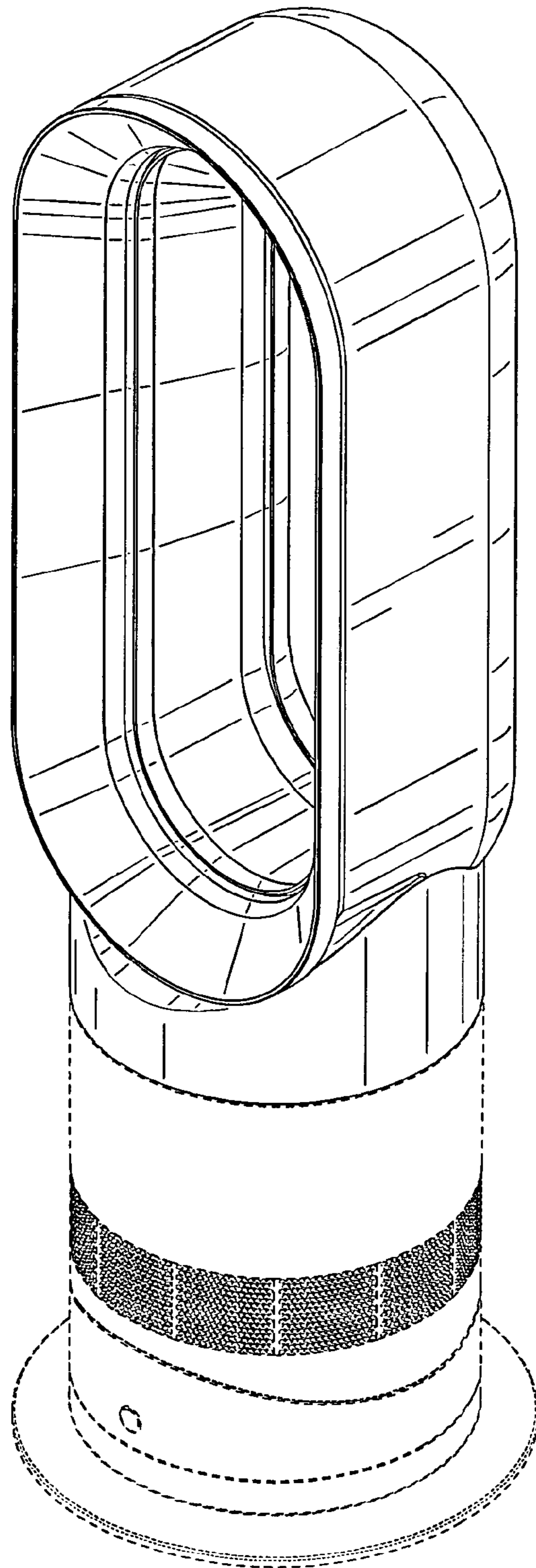

FIG. 1

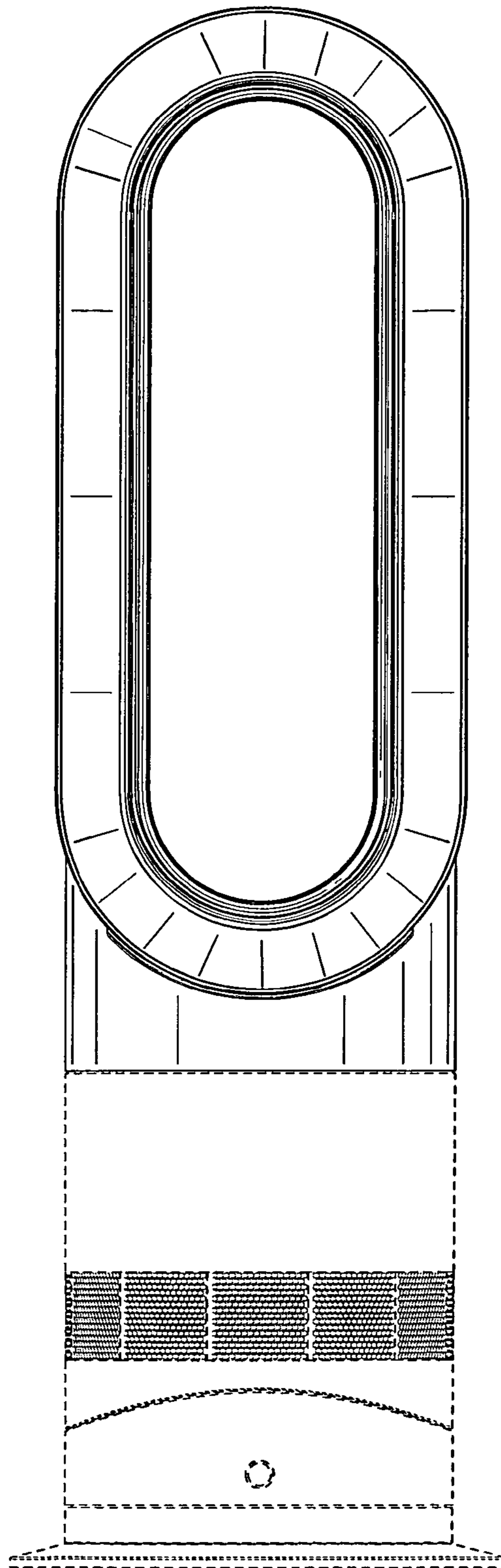

FIG. 2

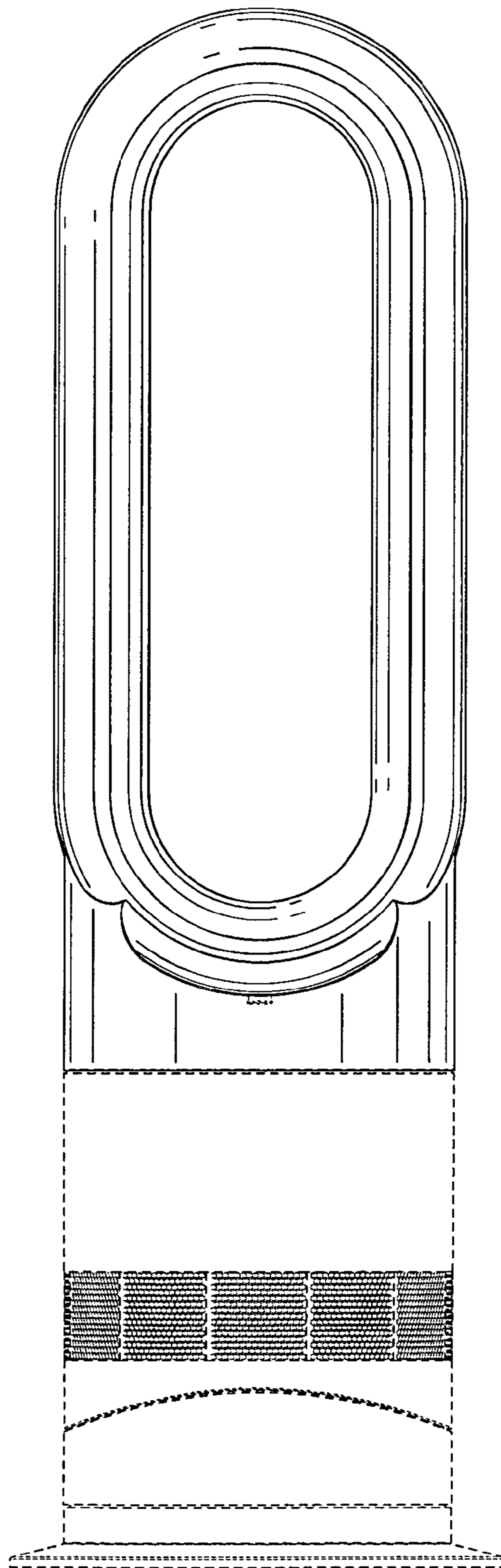

FIG. 3

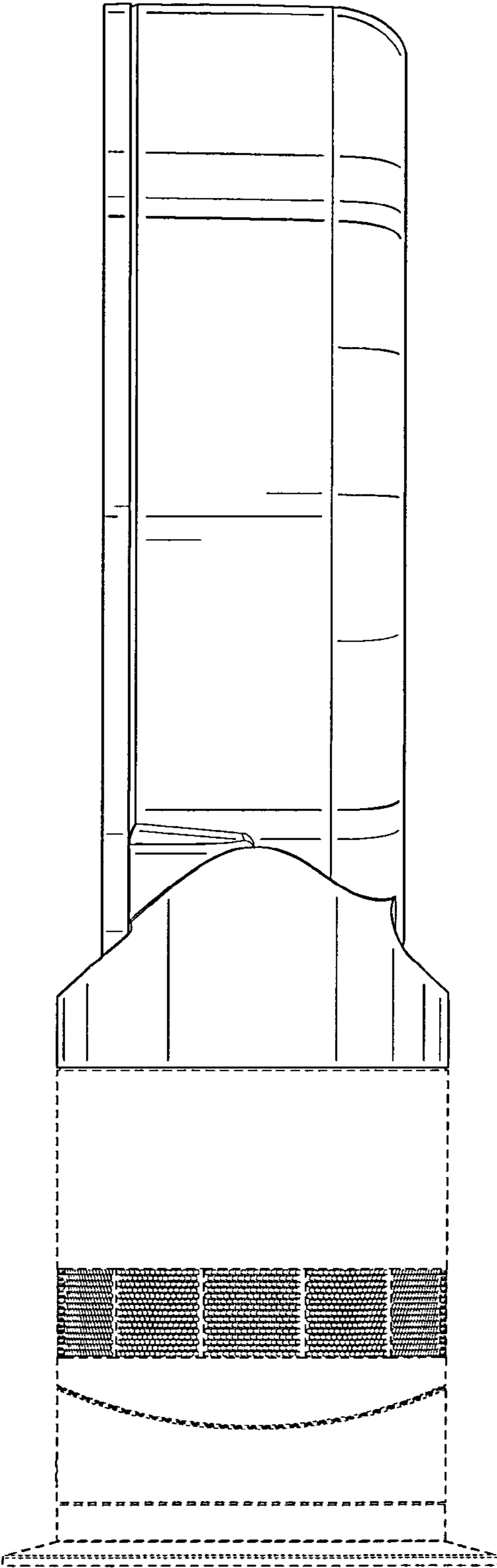

FIG. 4

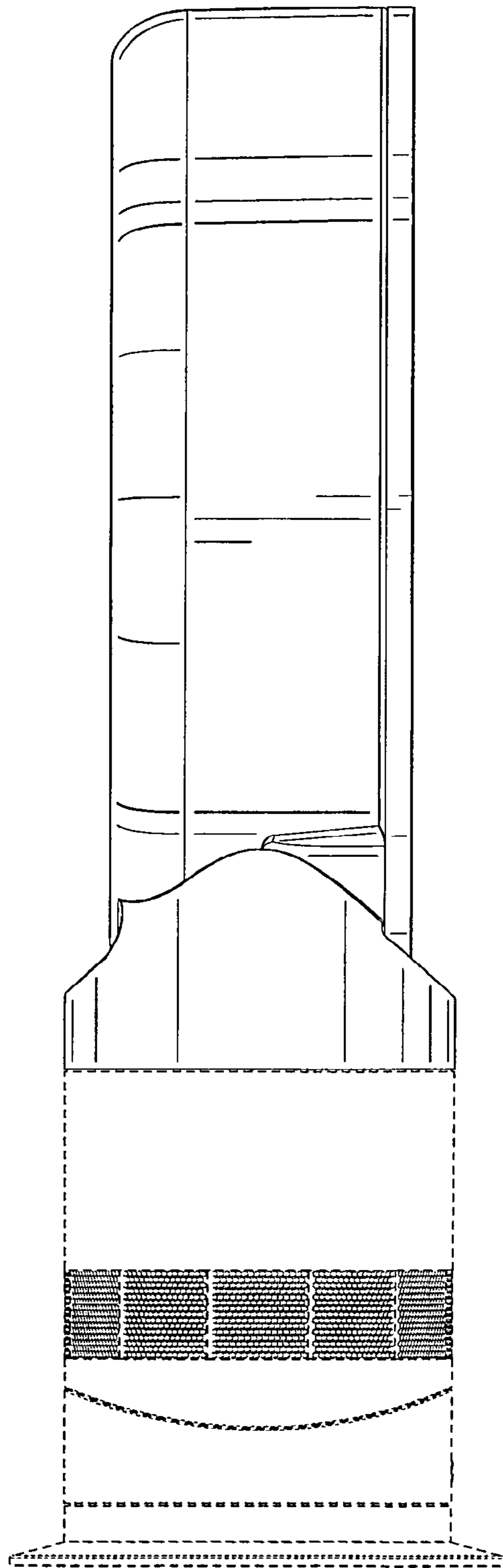

FIG. 5

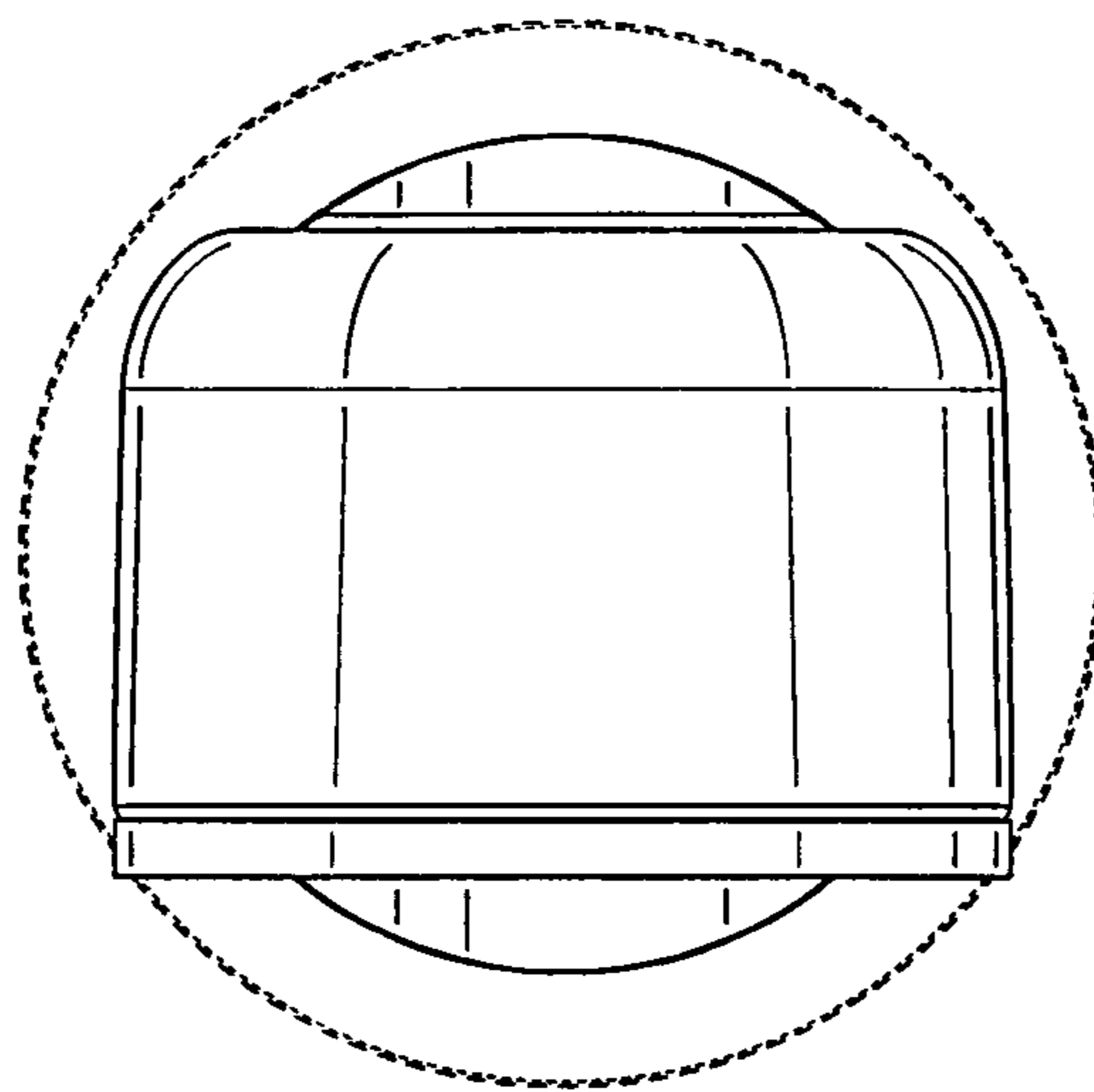

FIG. 6

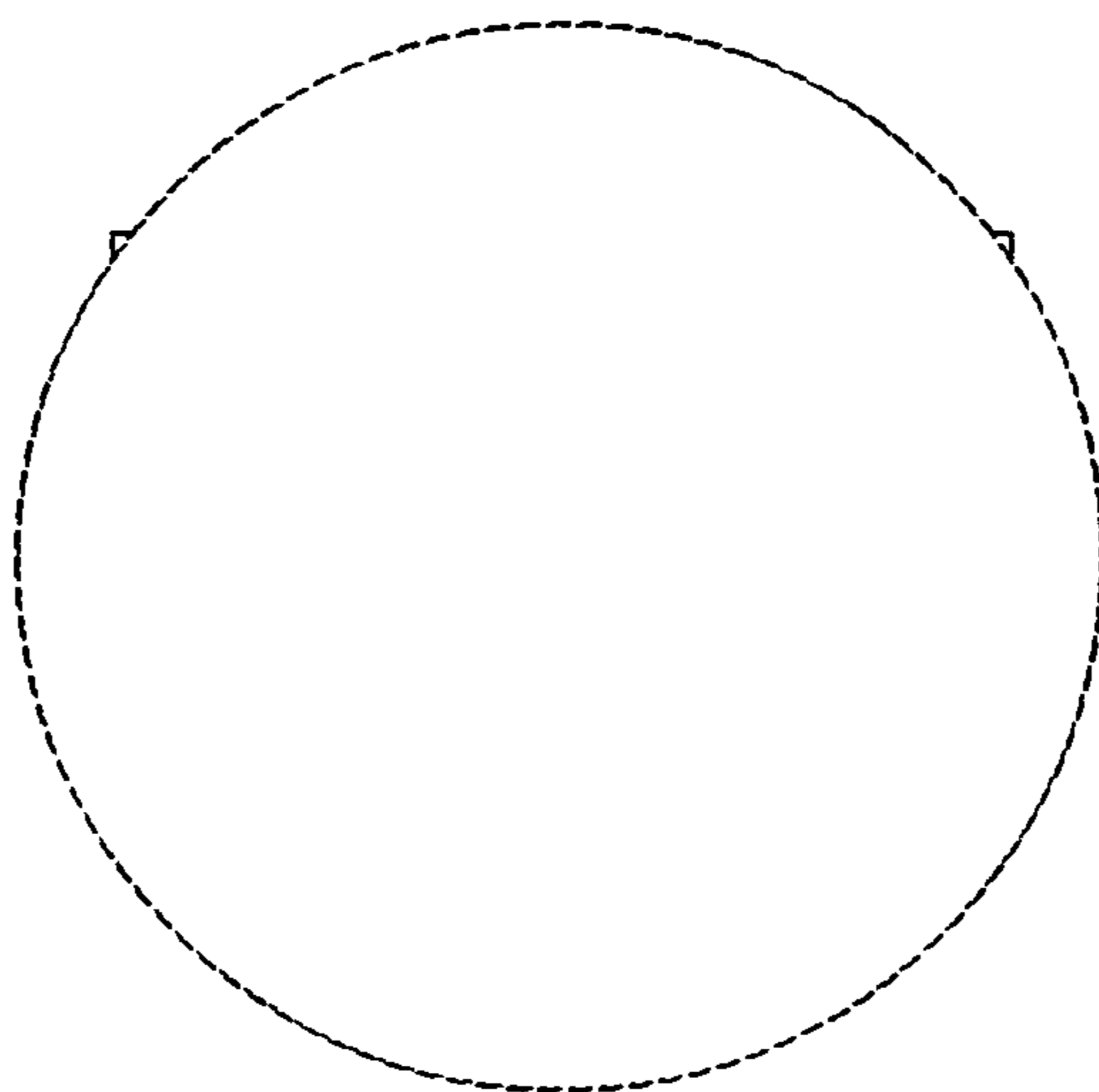

FIG. 7