

US00D728084S

(12) **United States Design Patent**  
**Lyons et al.**

(10) **Patent No.:** **US D728,084 S**  
(45) **Date of Patent:** **\*\* Apr. 28, 2015**

(54) **CURVED DOOR**

FOREIGN PATENT DOCUMENTS

(71) Applicant: **AS IP Holdco, LLC**, Piscataway, NJ  
(US)

DE 4125069 3/1992

(72) Inventors: **Alison J. Lyons**, Morristown, NJ (US);  
**Drew Yuhas**, Pennington, NJ (US)

OTHER PUBLICATIONS

(73) Assignee: **AS IP Holdco, LLC**, Piscataway, NJ  
(US)

MTI Baths, Enclosures—Shower Enclosures—Crescent Bow-Front Enclosure—N60BF, <http://mtibaths.com/products/enclosures/shower/N60BF>, retrieved on Mar. 11, 2013.

(\*\*) Term: **14 Years**

MTI Baths, Shower Bases—Designer Shower Bases—MTSB-6027-36, <http://mtibaths.com/products/shower-bases/designer/MTSB-6027-36>, retrieved on Mar. 11, 2013.

(21) Appl. No.: **29/459,399**

Fleurco, Novara, Bowfront 60, Curved Door and Panel, <http://fleurco.com/shower-doors/novara-bowfront-60.aspx>, retrieved on Mar. 11, 2013.

(22) Filed: **Jun. 28, 2013**

Fleurco, Roma, Bowfront, Curved Door and Panel, <http://fleurco.com/shower-doors/roma-bowfront.aspx>, retrieved on Mar. 11, 2013.

(51) **LOC (10) Cl.** ..... **23-02**

Fleurco, Banyo, Amalfi Bowfront, Semi-Frameless Curved Sliding Door With Return Panel, <http://fleurco.com/shower-doors/banyo-amalfi-bowfront-2-sides-semi-frameless-sliding-door.aspx>, retrieved on Mar. 11, 2013.

(52) **U.S. Cl.**

USPC ..... **D23/305**

(58) **Field of Classification Search**

USPC ..... D23/275, 279, 283, 303, 305;  
49/40-41, 409-412, 370; D25/48.1,  
D25/48.3; 160/201, 214; 4/552, 557, 607,  
4/610, 661

See application file for complete search history.

Fleurco, Sorrento, Bowfront, Curved Door and Panel With Return Panel, <http://fleurco.com/shower-doors/Bowfront-Curved-Door-and-Panel-with-Return-panel-131.aspx>, retrieved on Mar. 11, 2013.

Fleurco, Bowfront Acrylic Shower Base, <http://fleurco.com/bases/Bowfront-Acrylic-Shower-Base.aspx>, retrieved on Mar. 11, 2013.  
English abstract of DE4125069 (A1).

\* cited by examiner

(56) **References Cited**

U.S. PATENT DOCUMENTS

D217,866 S	6/1970	Myers	
4,807,312 A *	2/1989	Baus	4/607
4,882,795 A	11/1989	Baus	
4,974,269 A	12/1990	Baus	
D352,548 S	11/1994	Pinsky et al.	
D374,917 S	10/1996	Casden	
5,575,022 A *	11/1996	Duffy et al.	4/607
D392,724 S	3/1998	Lenardon	
6,023,889 A	2/2000	Husting et al.	
D444,862 S	7/2001	Slothower	
6,698,037 B2	3/2004	Lippe	
6,792,721 B1 *	9/2004	Montanari	4/613
D571,441 S	6/2008	Sauvageau et al.	
D590,052 S *	4/2009	Murphy	D23/283
8,495,772 B2 *	7/2013	Boonstra	4/557
D709,601 S *	7/2014	Sullivan	D23/305
2003/0208842 A1	11/2003	Laws	
2010/0031438 A1	2/2010	Boonstra	

*Primary Examiner* — Robert Delehanty

(74) *Attorney, Agent, or Firm* — Ladas & Parry LLP

(57) **CLAIM**

We claim the ornamental design for a curved door, as shown and described.

**DESCRIPTION**

FIG. 1 is a perspective view showing our new design according to a first embodiment, in particular showing a perspective view of a curved bypass door with both (sliding) doors closed. FIG. 2 is a front view showing our new design according to the first embodiment, in particular showing a front view of a curved bypass door with both doors closed.

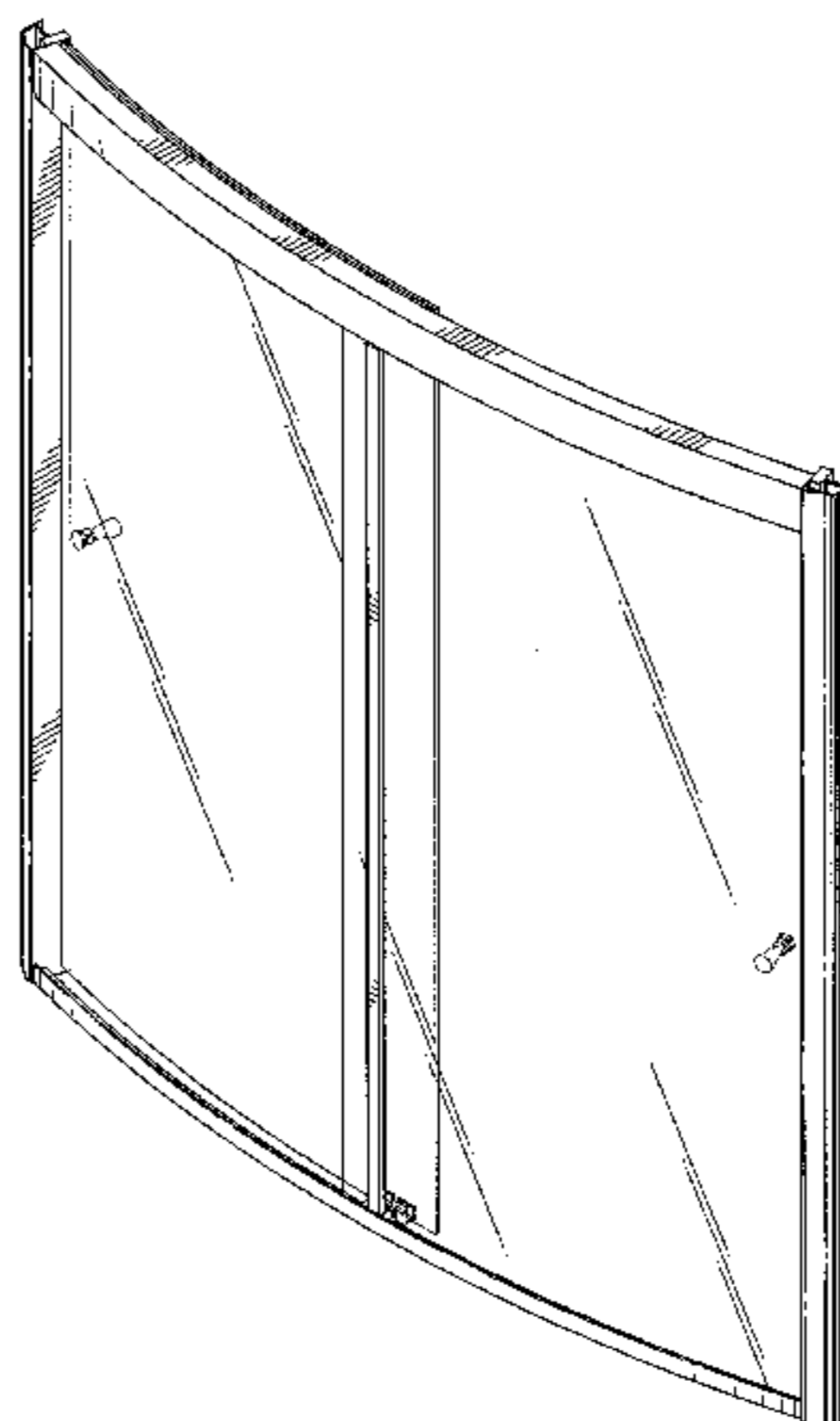

FIG. 3 is a back view showing our new design according to the first embodiment, in particular showing a back view of a curved bypass door with both doors closed.

FIG. 4 is a left side view showing our new design according to the first embodiment.

FIG. 5 is a right side view showing our new design according to the first embodiment.

FIG. 6 is a top view showing our new design according to the first embodiment.

FIG. 7 is a bottom view showing our new design according to the first embodiment.

FIG. 8 is a perspective view showing our new design according to the first embodiment, in particular showing a perspective view of a curved bypass door with both doors closed and a wall surround and tub base shown in broken lines.

FIG. 9 is a perspective view showing our new design according to the first embodiment, in particular showing a perspective view of a curved bypass door with both doors closed and a wall surround and shower base shown in broken lines.

FIG. 10 is a perspective view showing our new design according to the first embodiment, in particular showing a perspective view of a curved bypass door with the right door open.

FIG. 11 is a perspective view showing our new design according to the first embodiment, in particular showing a perspective view of a curved bypass door with the left door open.

FIG. 12 is a perspective view showing our new design according to a second embodiment, in particular showing a perspective view of a curved door with one side (the right door) fixed and the left (sliding) door closed.

FIG. 13 is a front view showing our new design according to the second embodiment, in particular showing a front view of a curved door with one side (the right door) fixed and the left door closed.

FIG. 14 is a back view showing our new design according to the second embodiment, in particular showing a back view of a curved door with one side (the right door) fixed and the left door closed.

FIG. 15 is a left side view showing our new design according to the second embodiment.

FIG. 16 is a right side view showing our new design according to the second embodiment.

FIG. 17 is a top view showing our new design according to the second embodiment with the left door closed.

FIG. 18 is a bottom view showing our new design according to the second embodiment with the left door closed.

FIG. 19 is a perspective view showing our new design according to the second embodiment, in particular showing a perspective view of a curved door with one side (the right door) fixed and the left door open.

FIG. 20 is a perspective view showing our new design according to the second embodiment, in particular showing a perspective view of a curved door with one side (the right door) fixed and the left door closed and a wall surround and shower base shown in broken lines.

FIG. 21 is a perspective view showing our new design according to the second embodiment, in particular showing a perspective view of a curved door with one side (the right door) fixed and the left door closed and a wall surround and tub base shown in broken lines.

FIG. 22 is a perspective view showing our new design according to a third embodiment, in particular showing a perspective view of a curved door with one side (the left door) fixed and the right (sliding) door closed.

FIG. 23 is a front view showing our new design according to the third embodiment, in particular showing a front view of a curved door with one side (the left door) fixed and the right door closed.

FIG. 24 is a back view showing our new design according to the third embodiment, in particular showing a back view of a curved door with one side (the left door) fixed and the right door closed.

FIG. 25 is a left side view showing our new design according to the third embodiment.

FIG. 26 is a right side view showing our new design according to the third embodiment.

FIG. 27 is a top view showing our new design according to the third embodiment with the right door closed.

FIG. 28 is a bottom view showing our new design according to the third embodiment with the right door closed.

FIG. 29 is a perspective view showing our new design according to the third embodiment, in particular showing a perspective view of a curved door with one side (the left door) fixed and the right door open.

FIG. 30 is a perspective view showing our new design according to the third embodiment, in particular showing a perspective view of a curved door with one side (the left door) fixed and the right door closed and a wall surround and shower base shown in broken lines.

FIG. 31 is a perspective view showing our new design according to the third embodiment, in particular showing a perspective view of a curved door with one side (the left door) fixed and the right door closed and a wall surround and tub base shown in broken lines.

FIG. 32 is a perspective view showing our new design according to a fourth embodiment, in particular showing a perspective view of a curved bypass door with both (sliding) doors closed and knobs shown in solid lines.

FIG. 33 is a front view showing our new design according to the fourth embodiment, in particular showing a front view of a curved bypass door with both doors closed.

FIG. 34 is a back view showing our new design according to the fourth embodiment, in particular showing a back view of a curved bypass door with both doors closed.

FIG. 35 is a left side view showing our new design according to the fourth embodiment.

FIG. 36 is a right side view showing our new design according to the fourth embodiment.

FIG. 37 is a top view showing our new design according to the fourth embodiment; and,

FIG. 38 is a bottom view showing our new design according to the fourth embodiment.

The curved door is particularly usable with a shower or tub. The broken lines shown in the drawings represent unclaimed portions of the design.

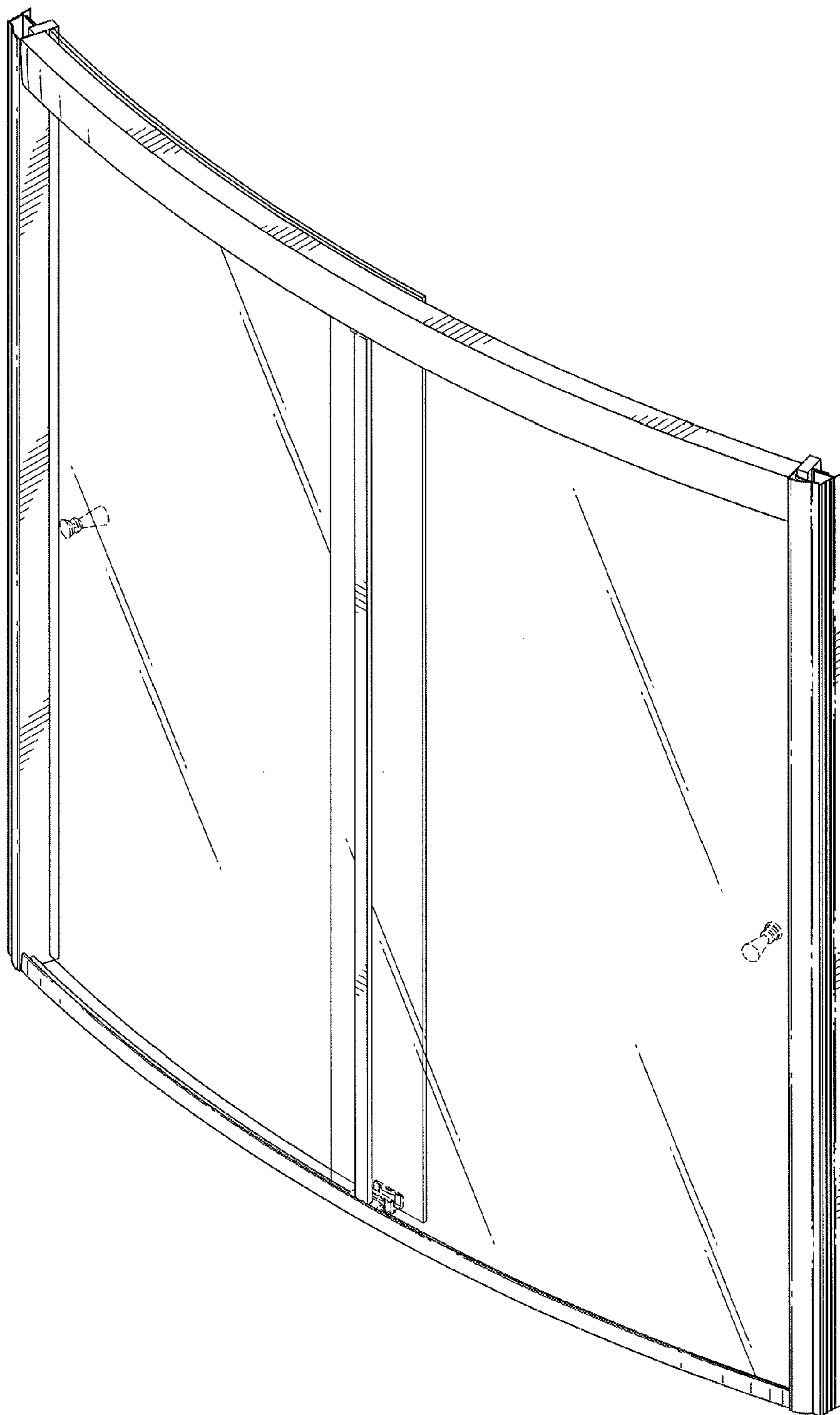

FIG. 1

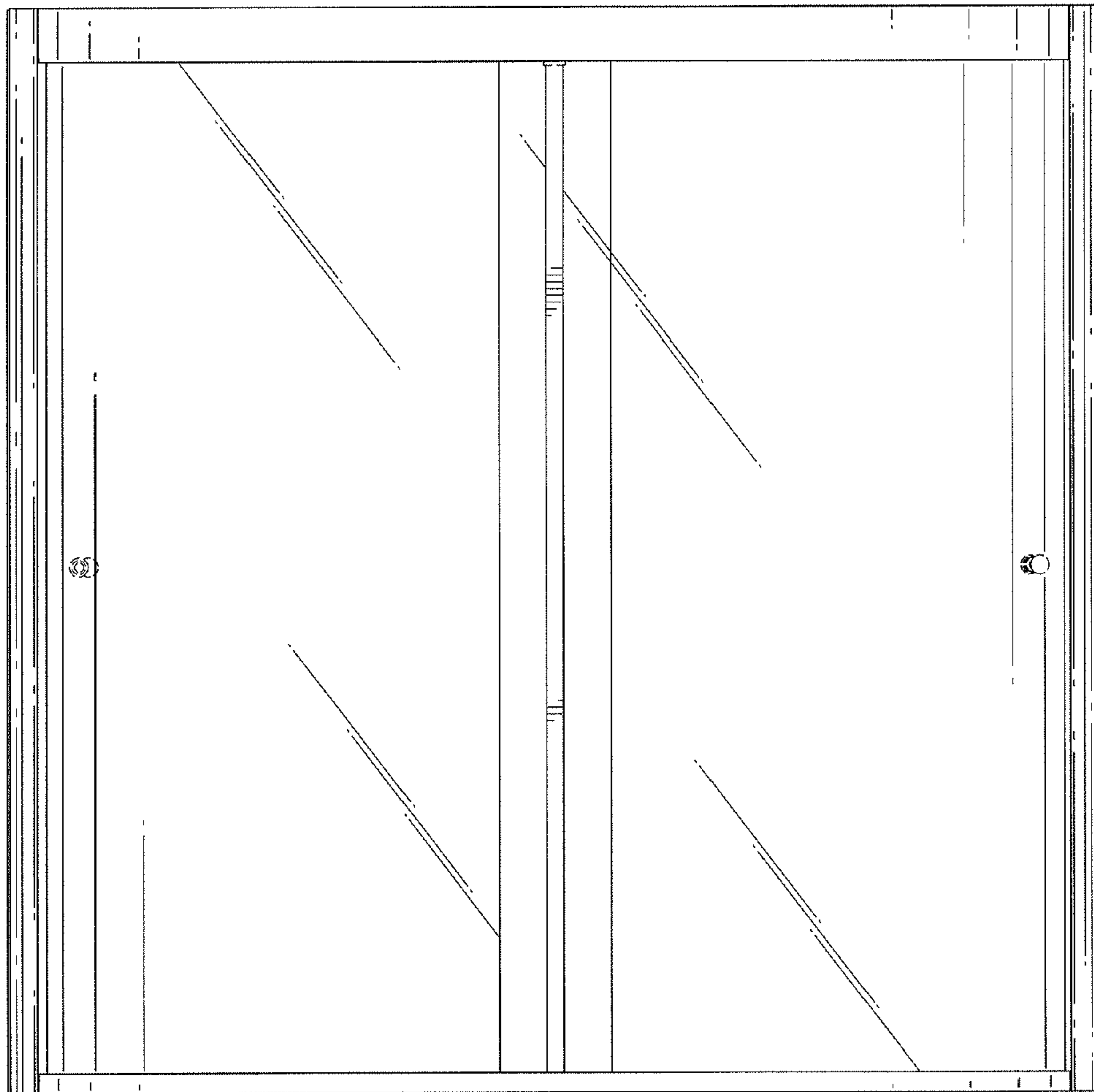

FIG. 2

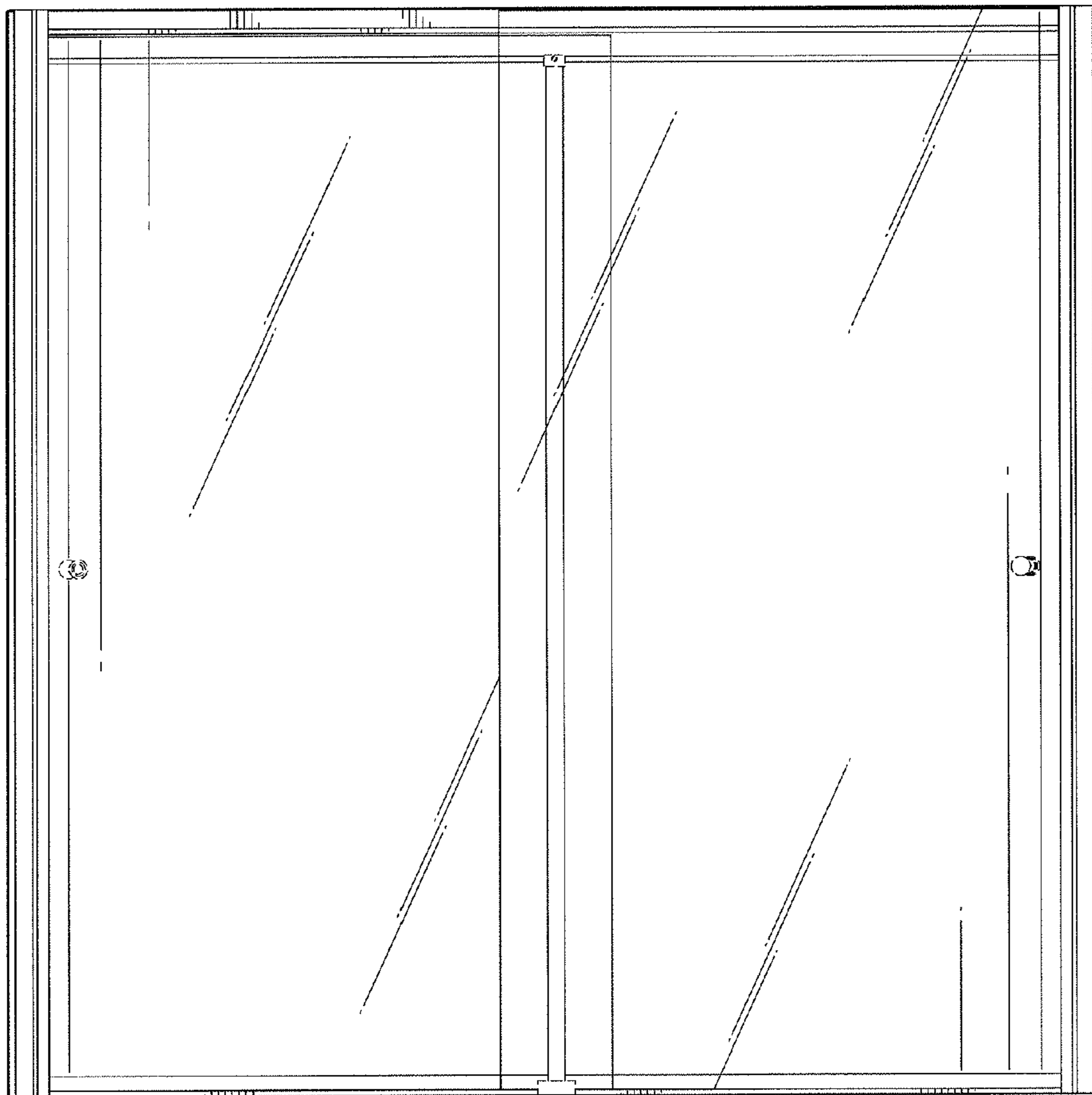

FIG.3

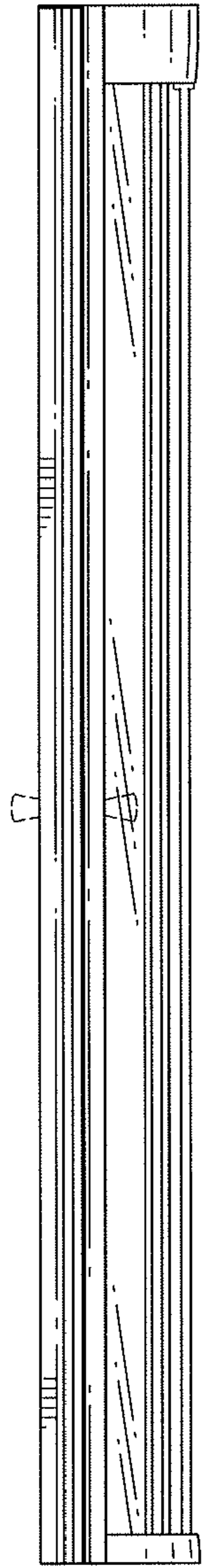

FIG. 4

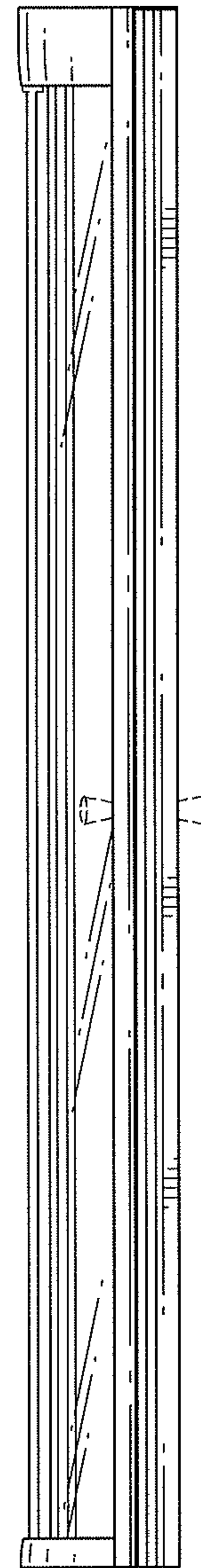

FIG. 5

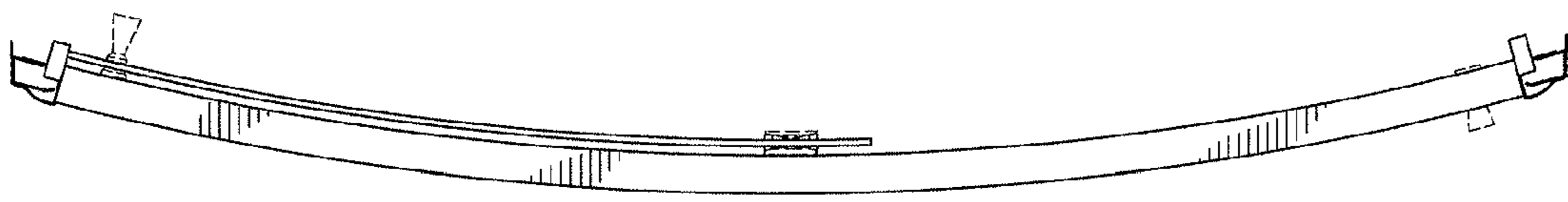

FIG. 6

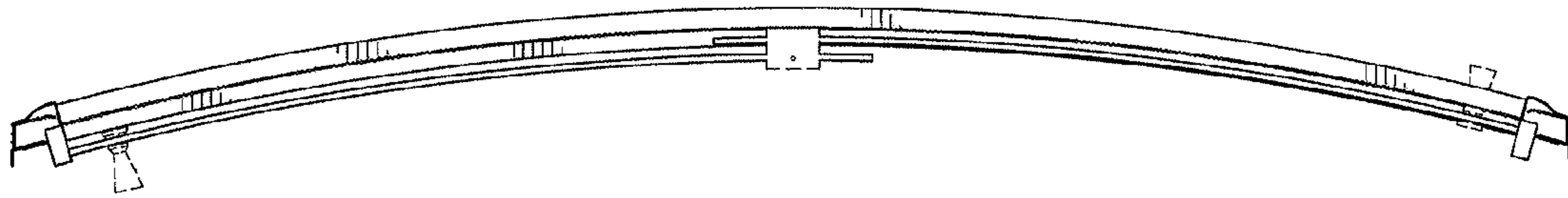

FIG. 7

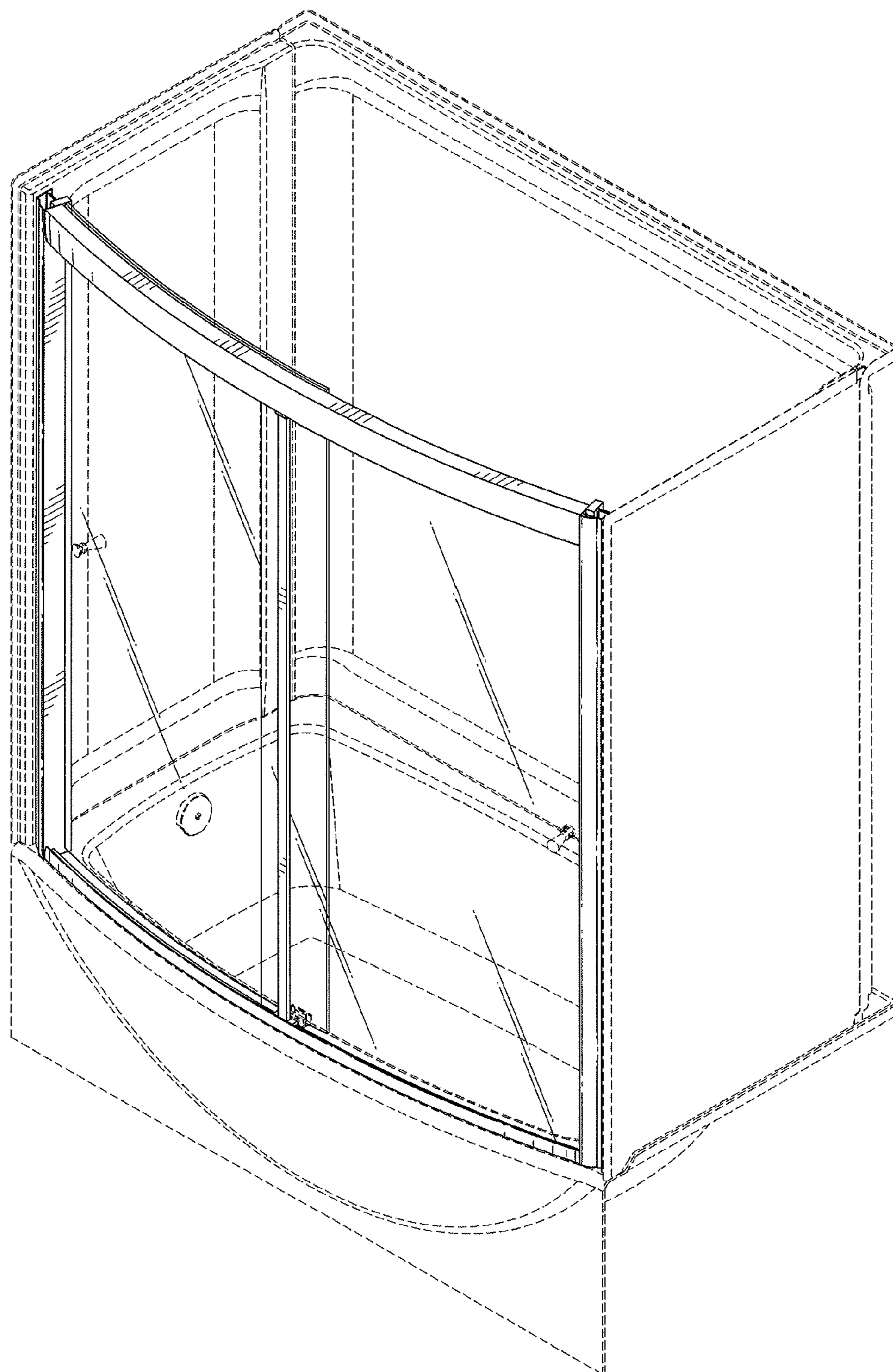

FIG. 8



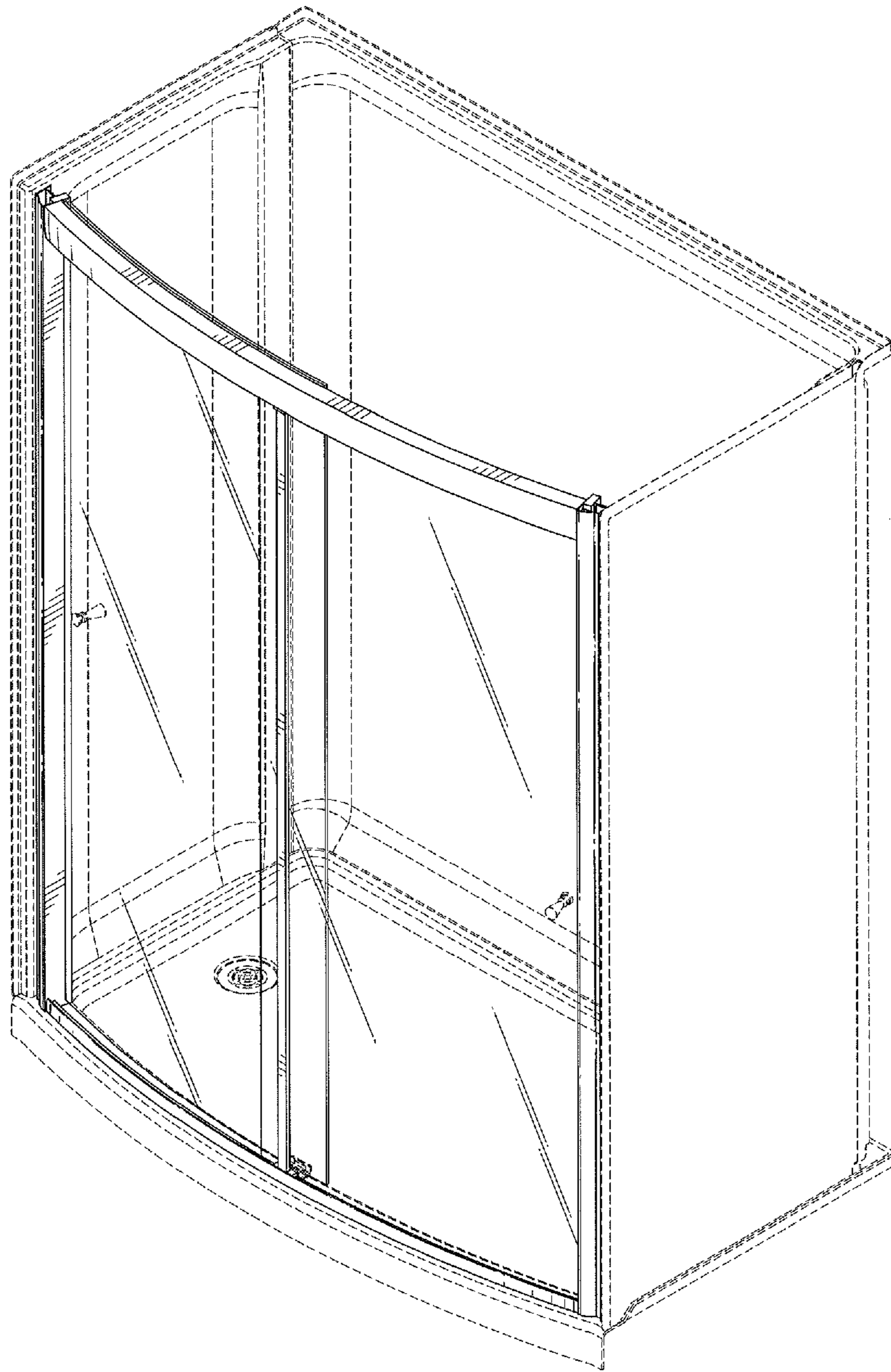

FIG. 9

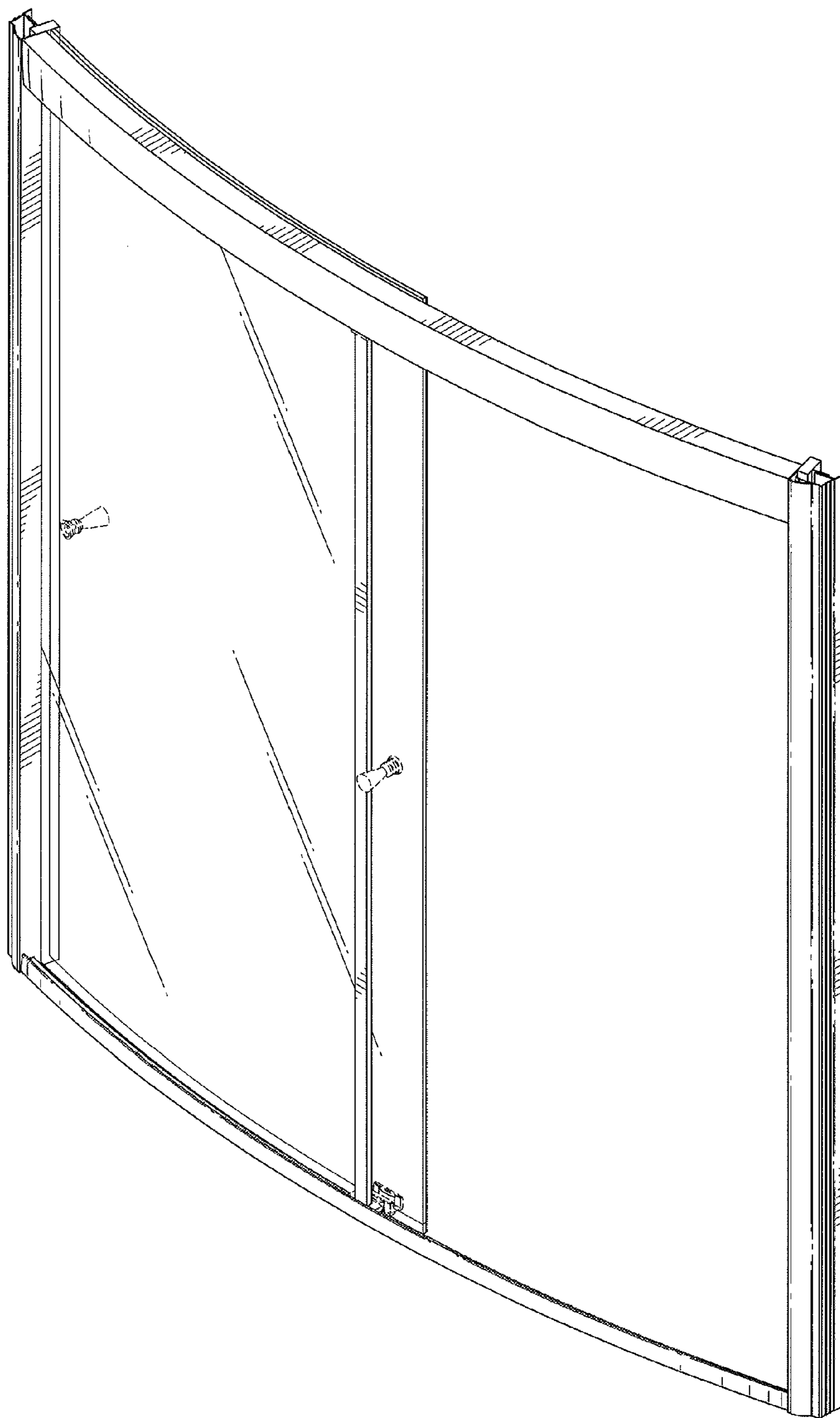

FIG. 10

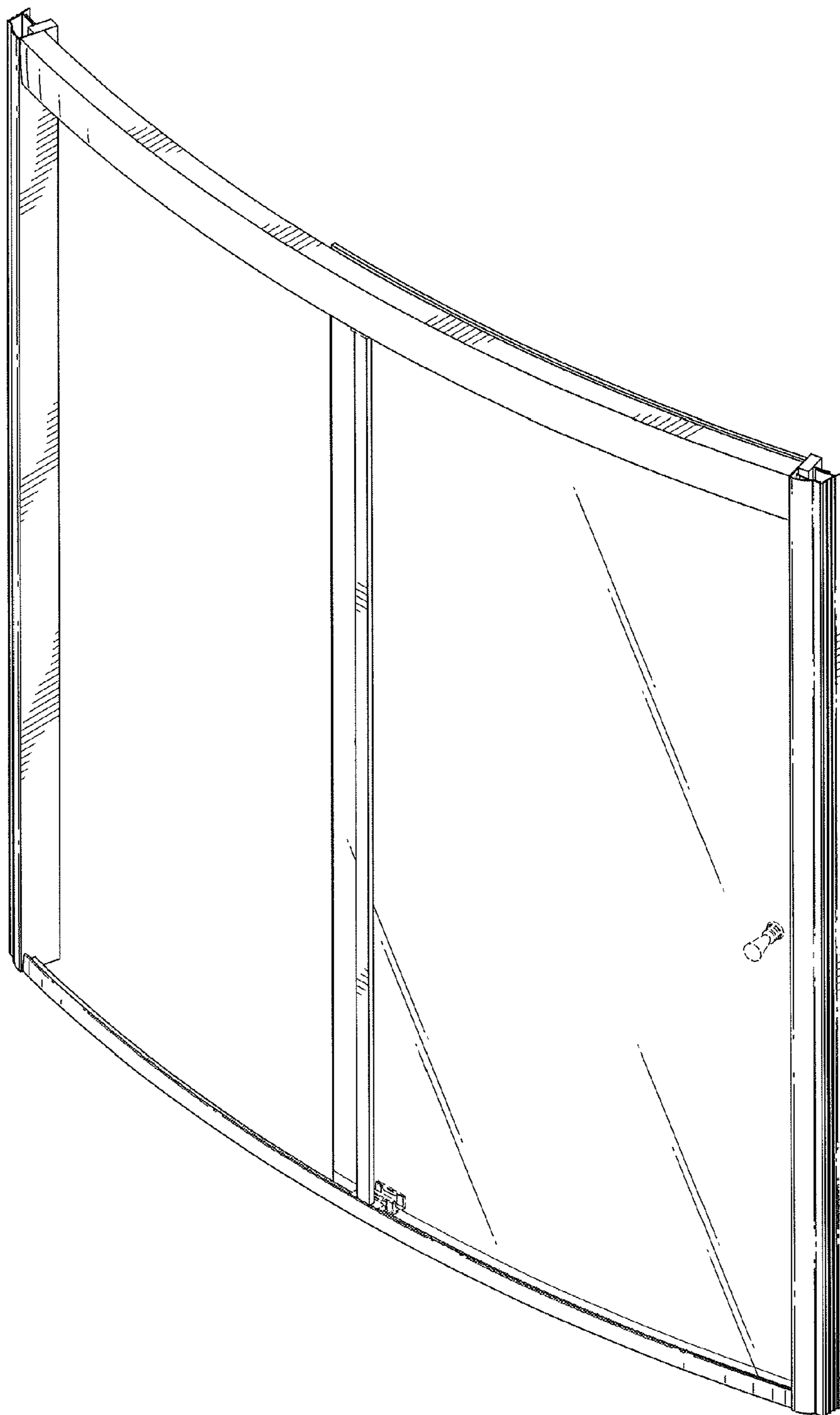

FIG. 11

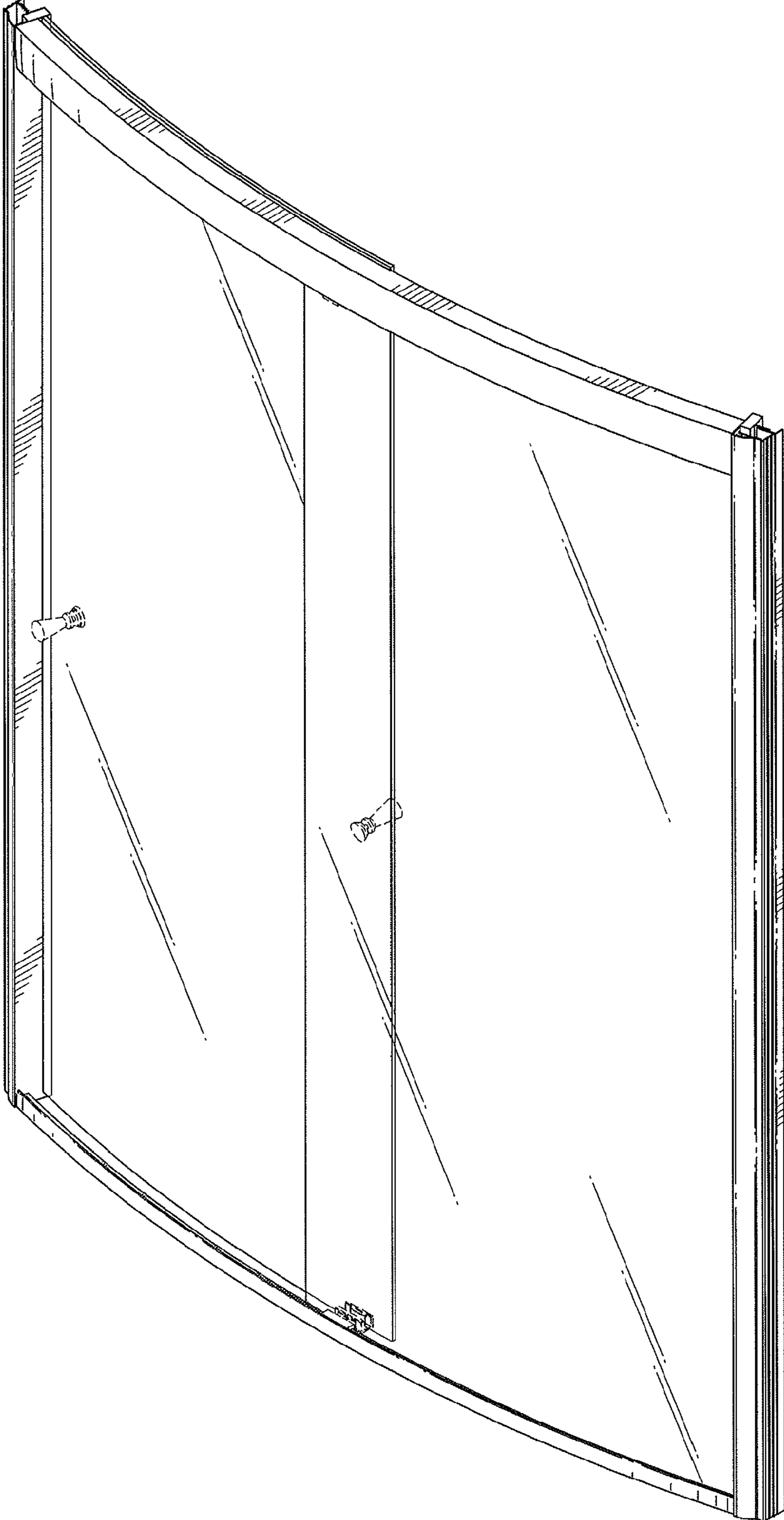

FIG. 12

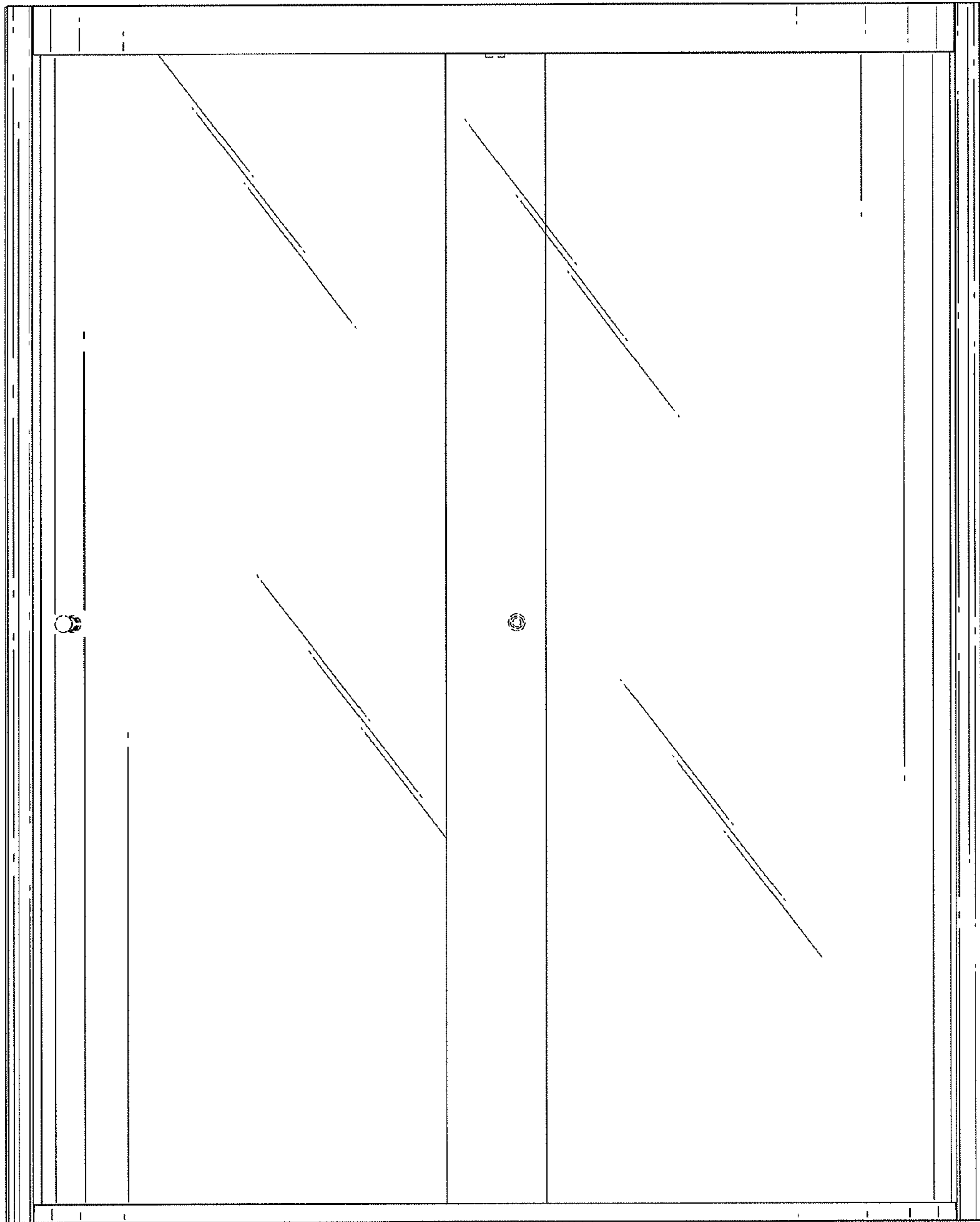

FIG. 13

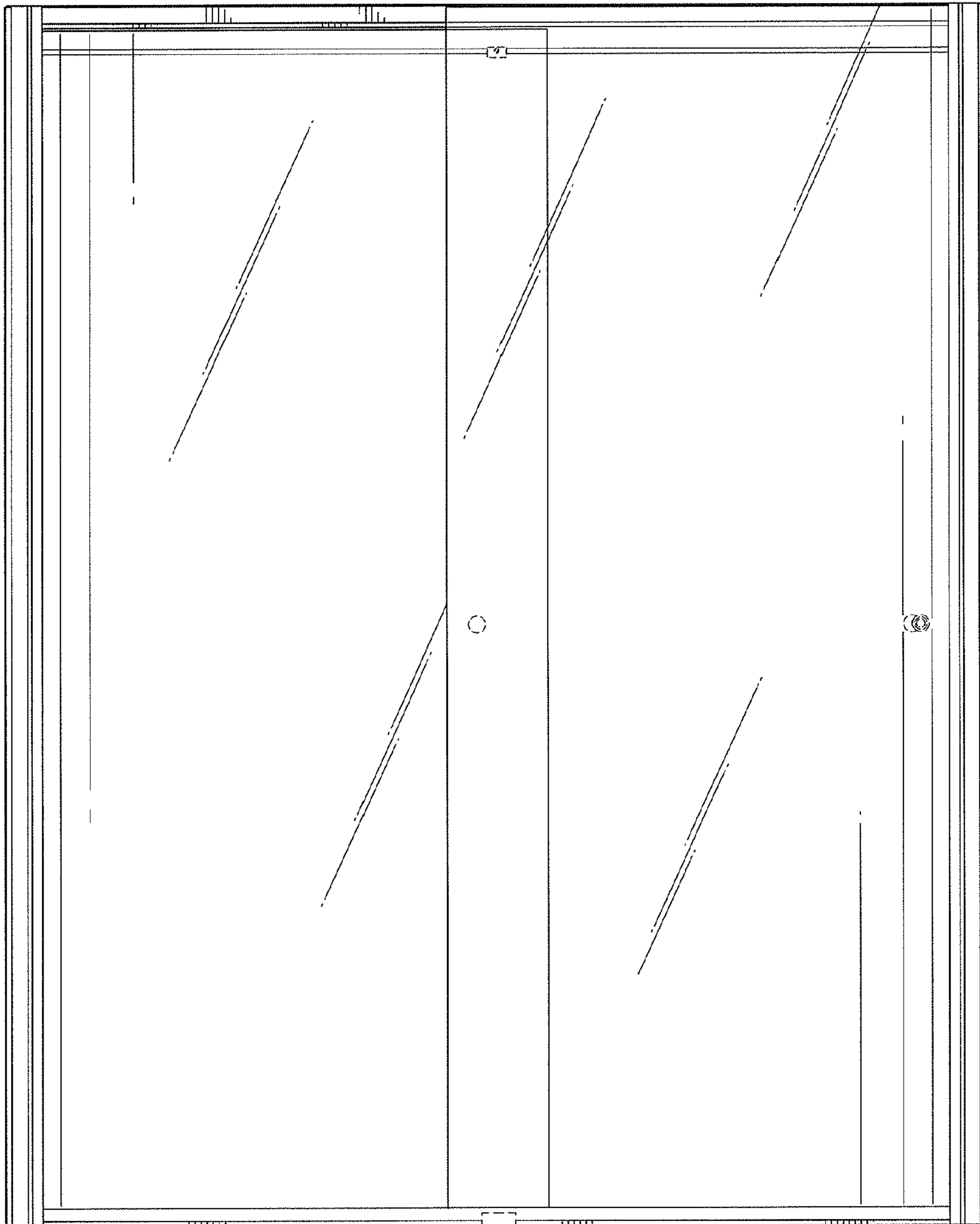

FIG.14

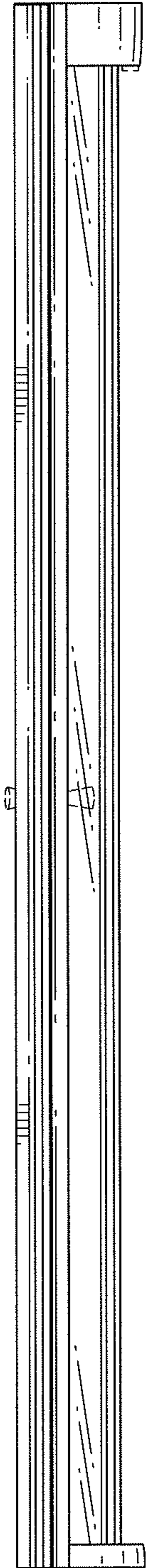

FIG. 15

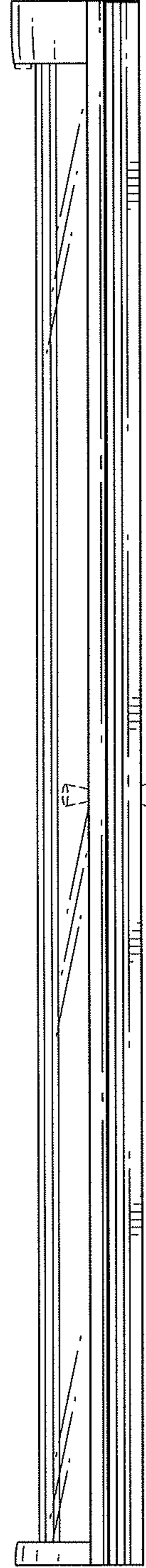

FIG. 16

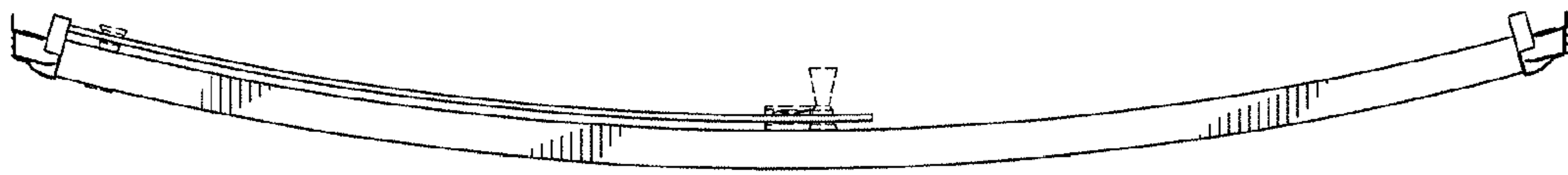

FIG. 17

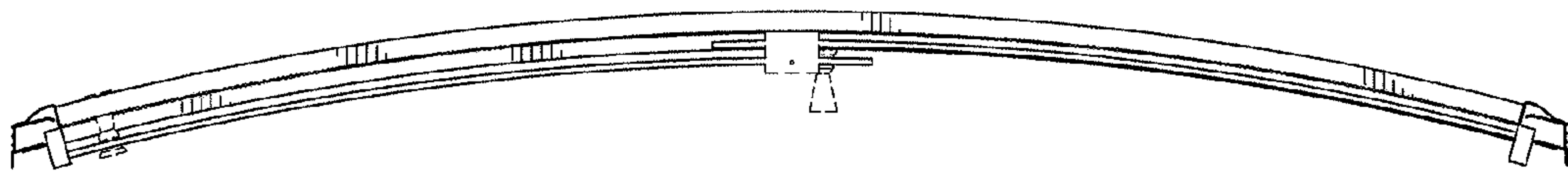

FIG. 18



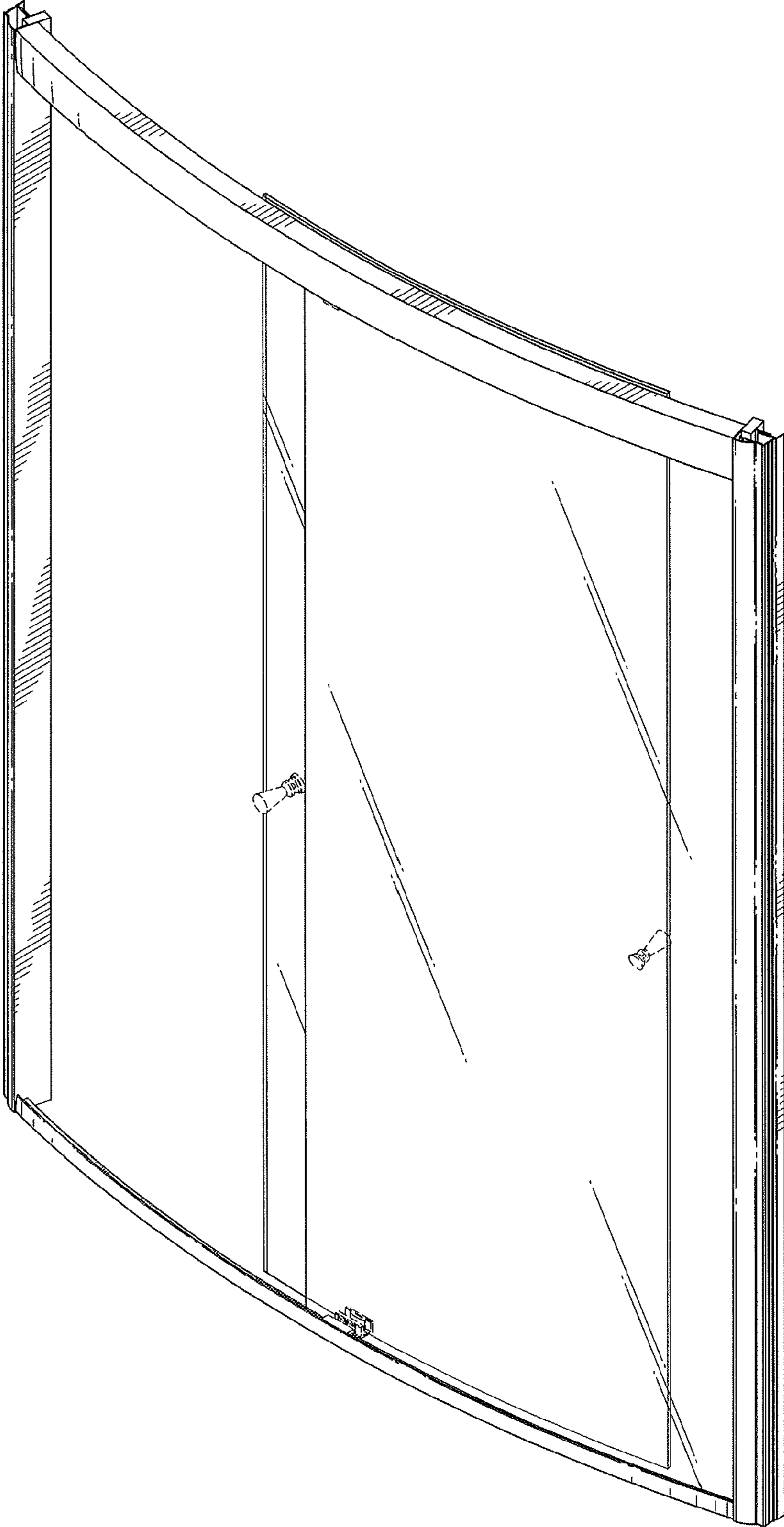

FIG. 19

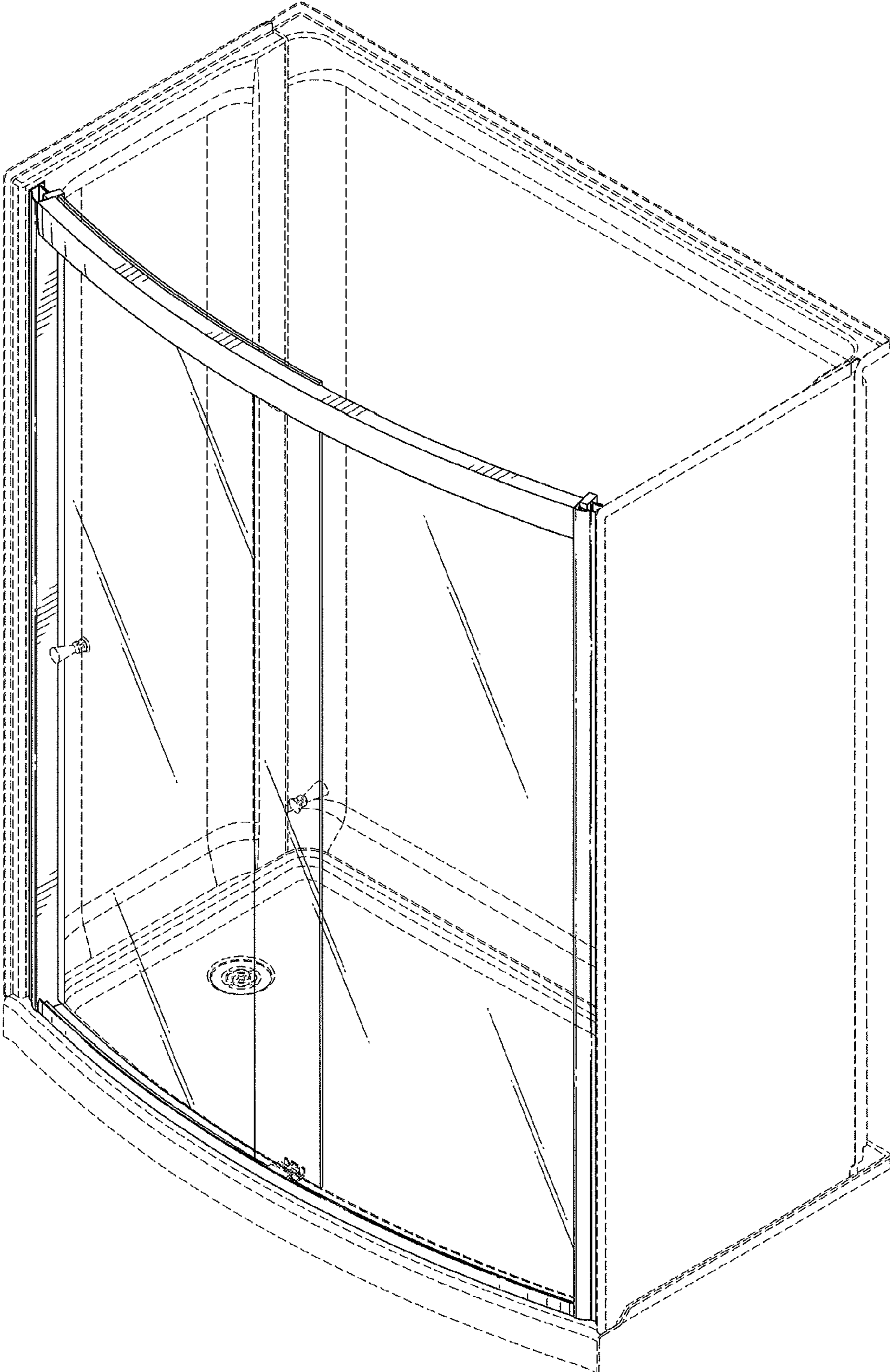

FIG. 20

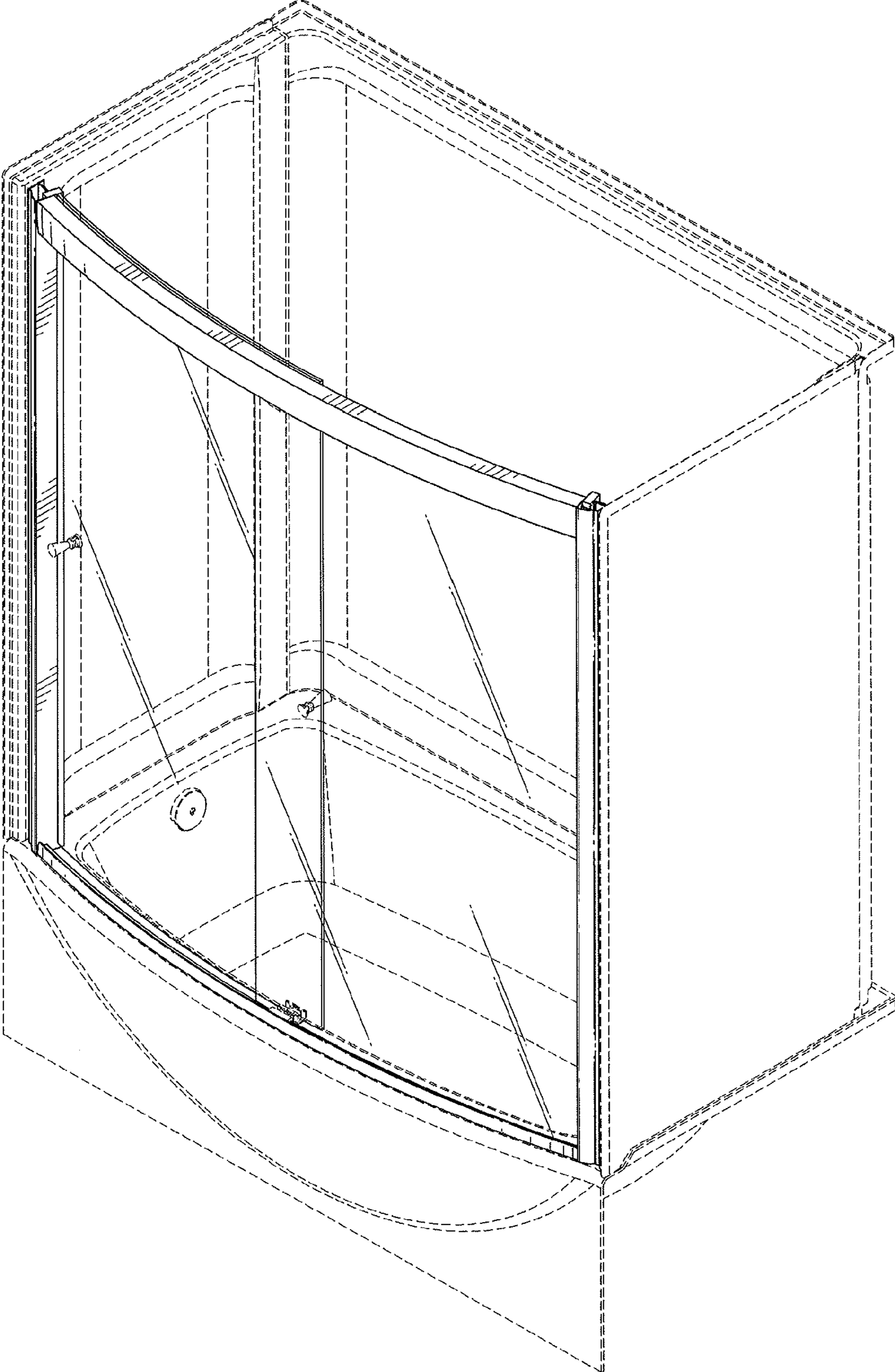

FIG.21

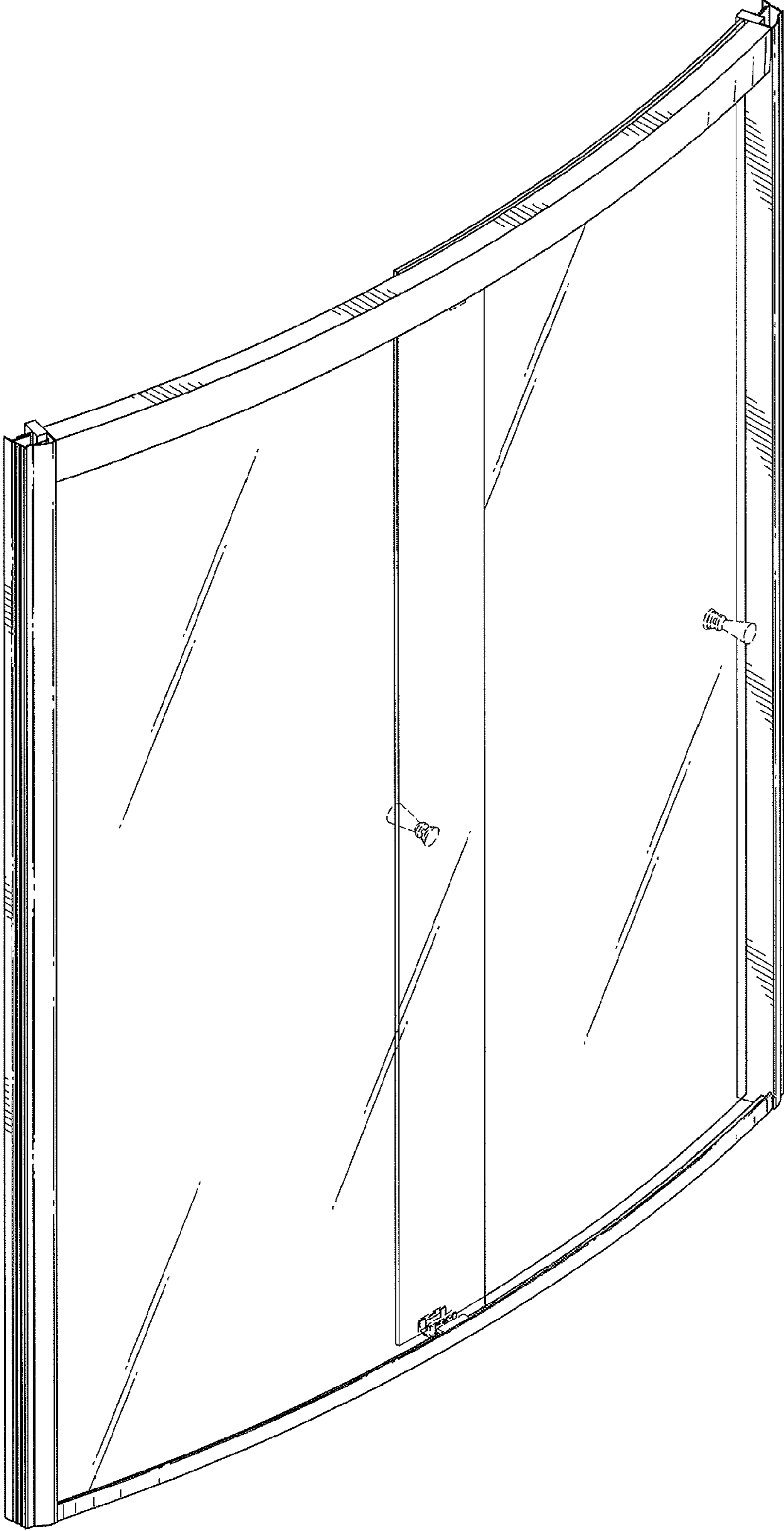

FIG. 22

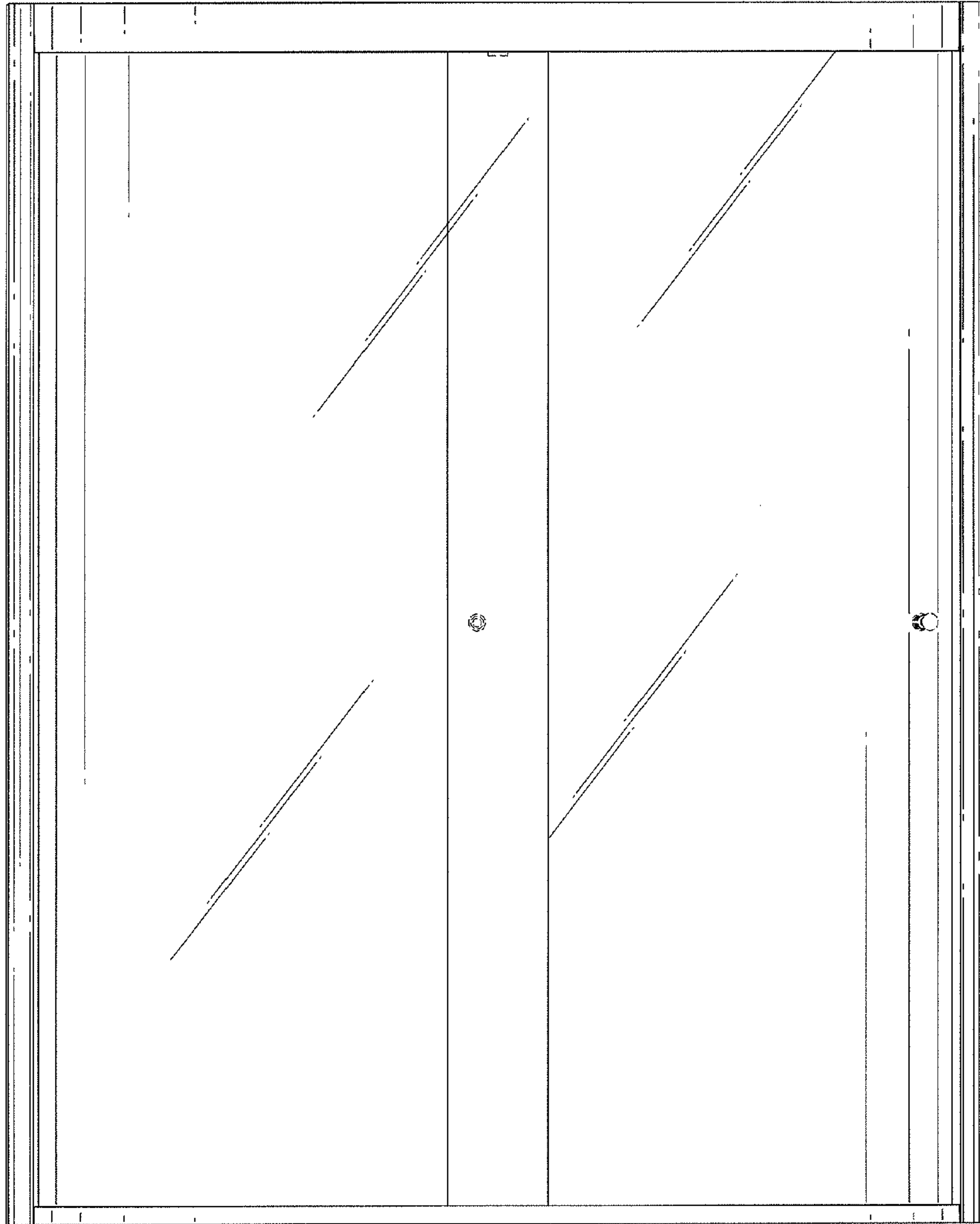

FIG.23

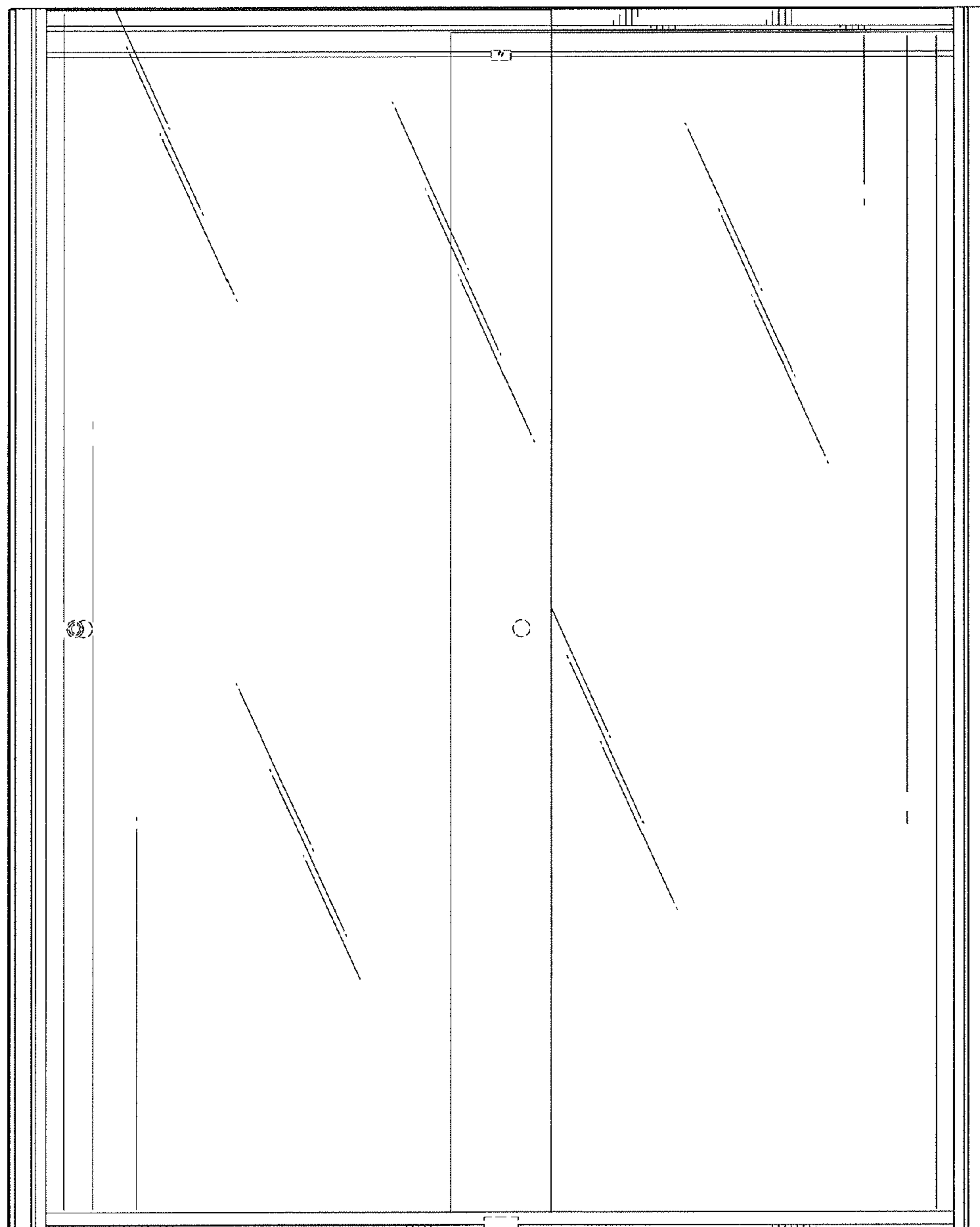

FIG.24

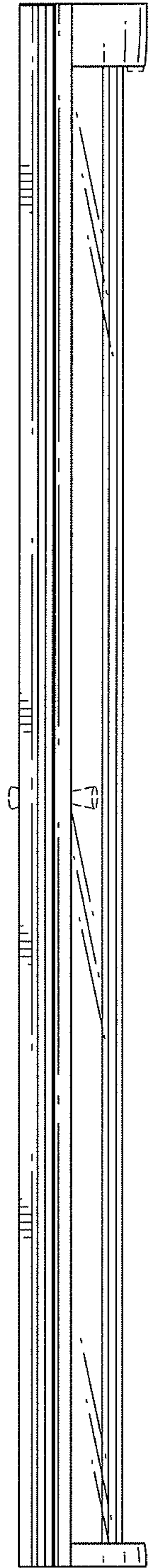

FIG. 25

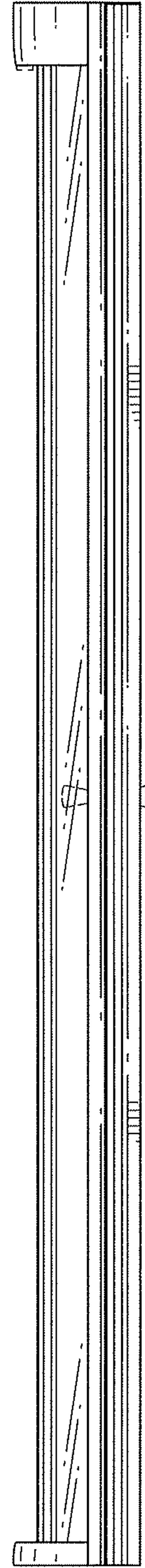

FIG. 26

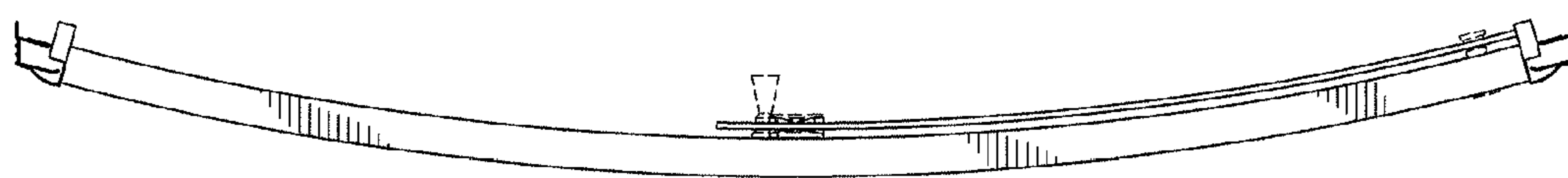

FIG. 27

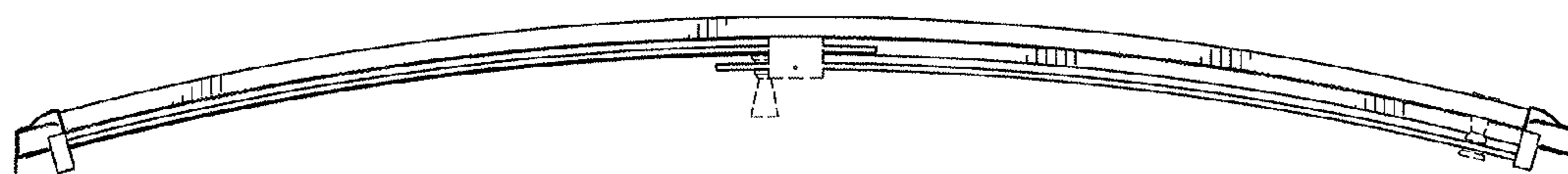

FIG. 28





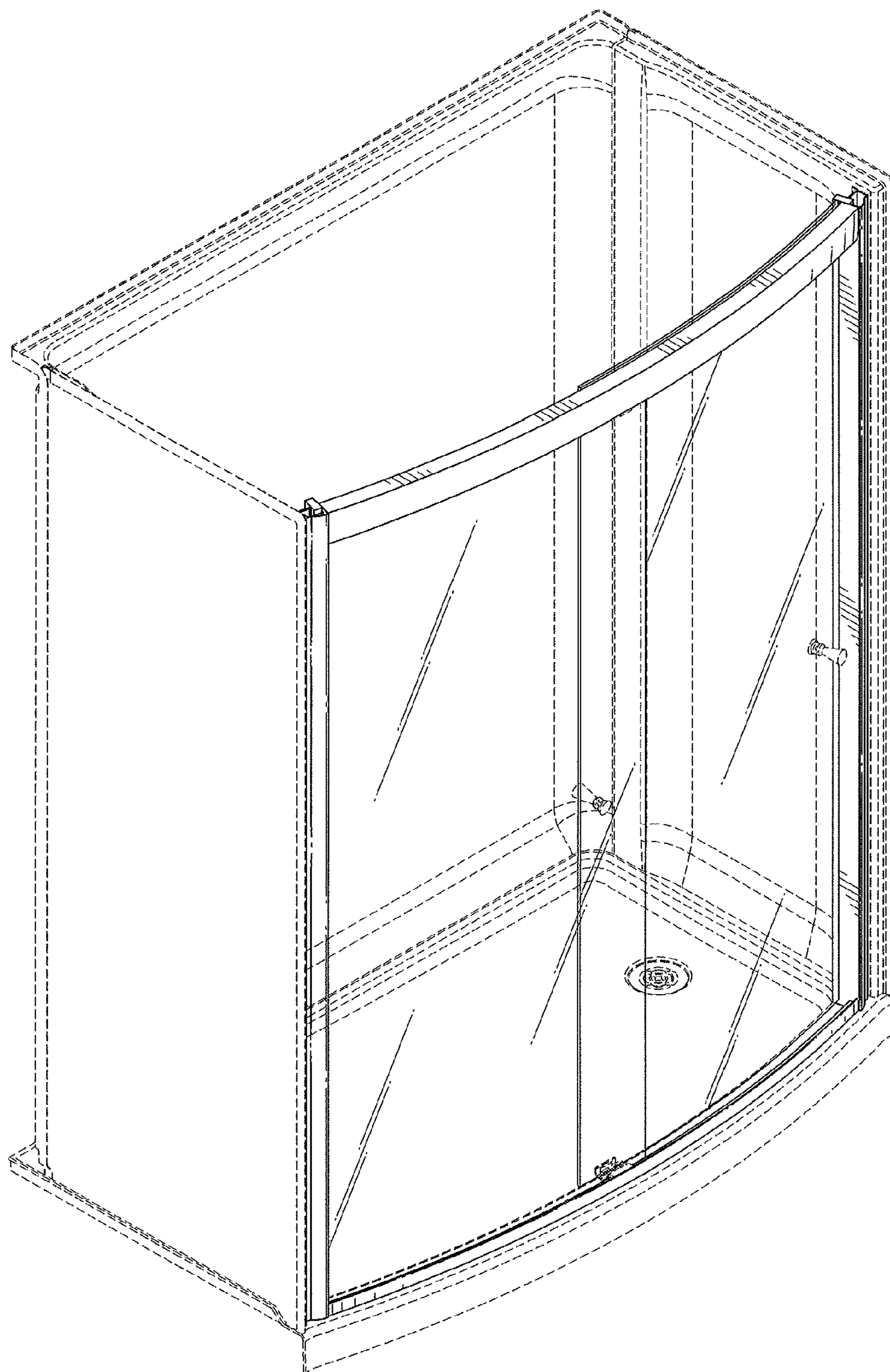

FIG. 30

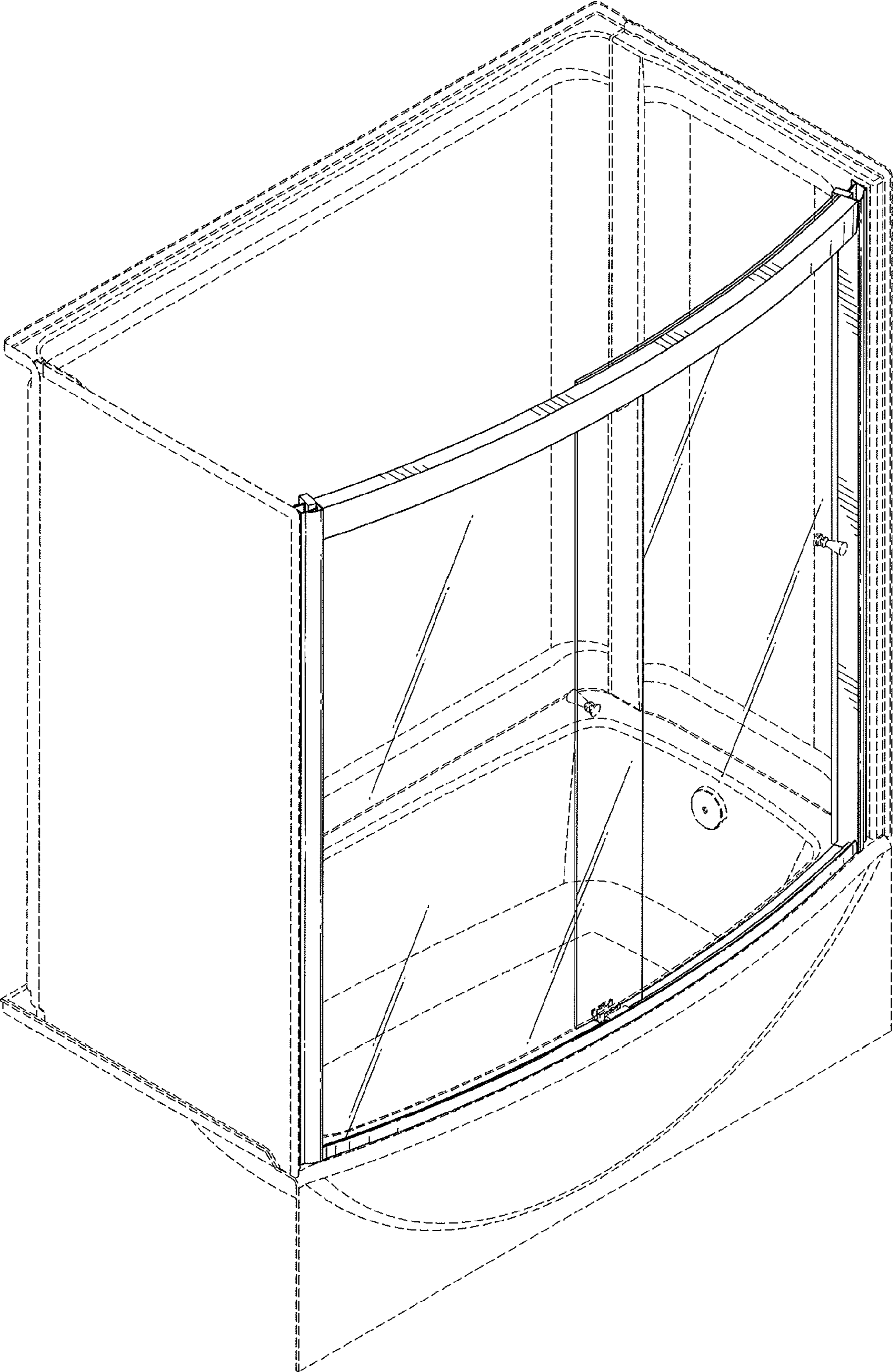

FIG.31

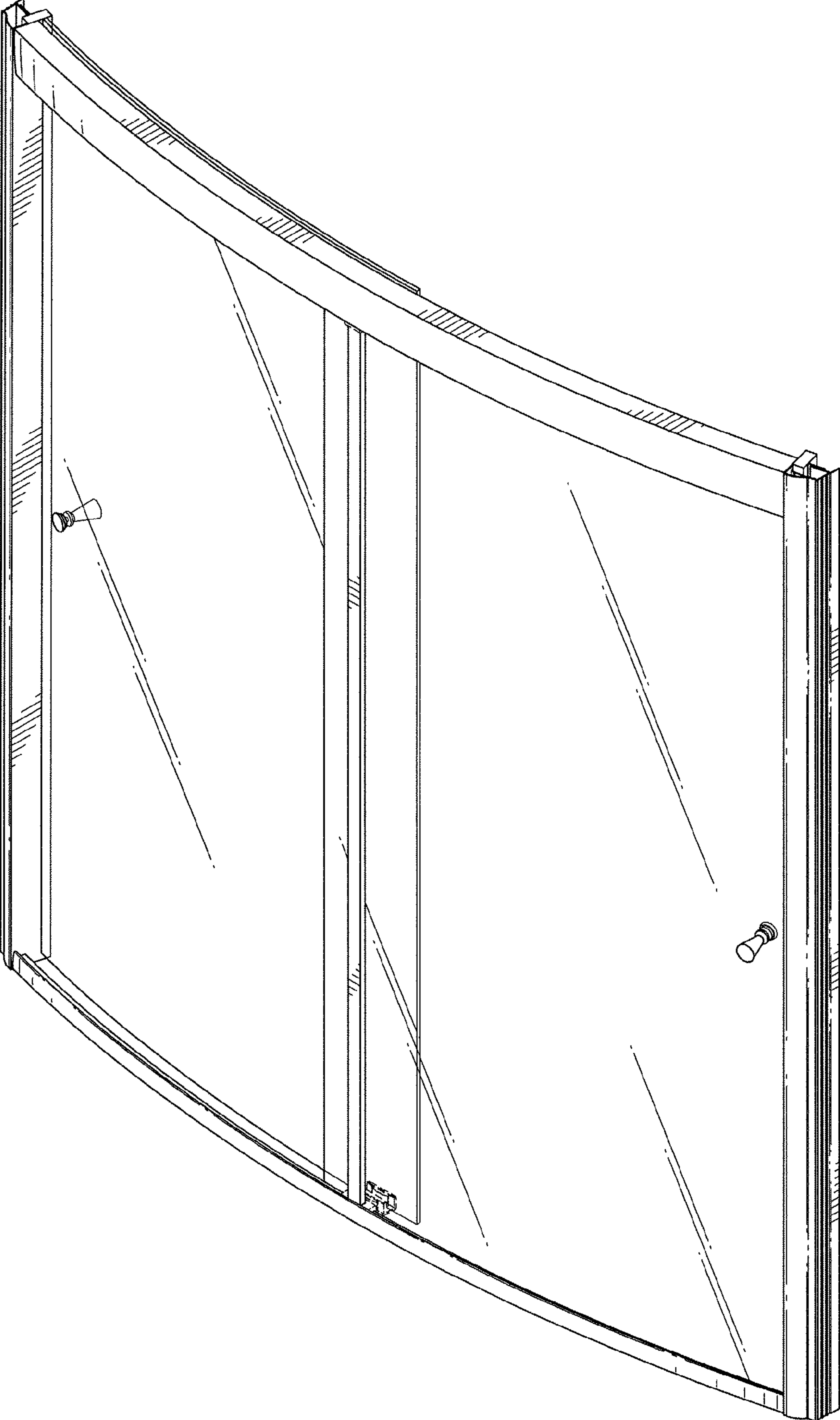

FIG.32

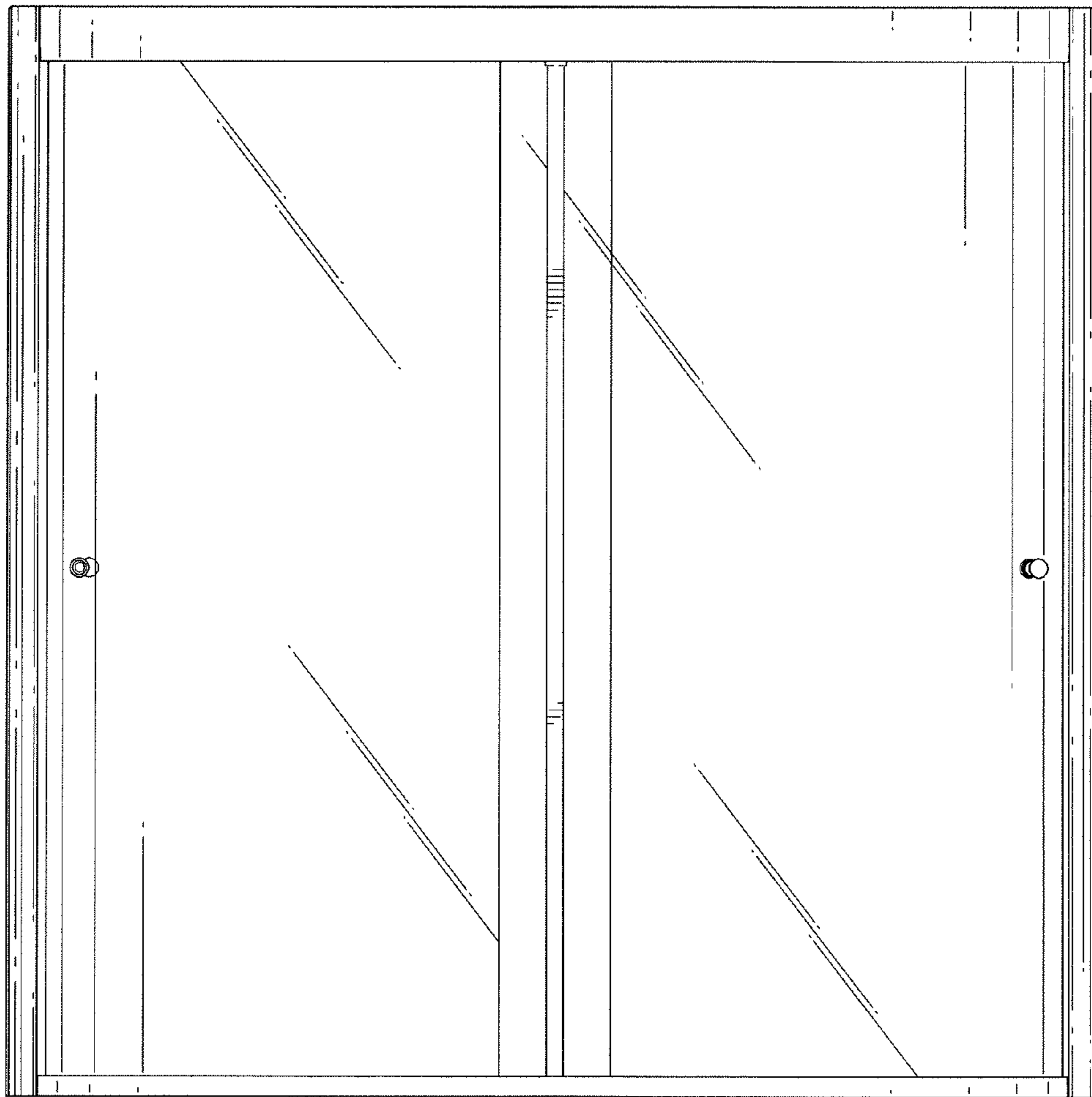

FIG. 33

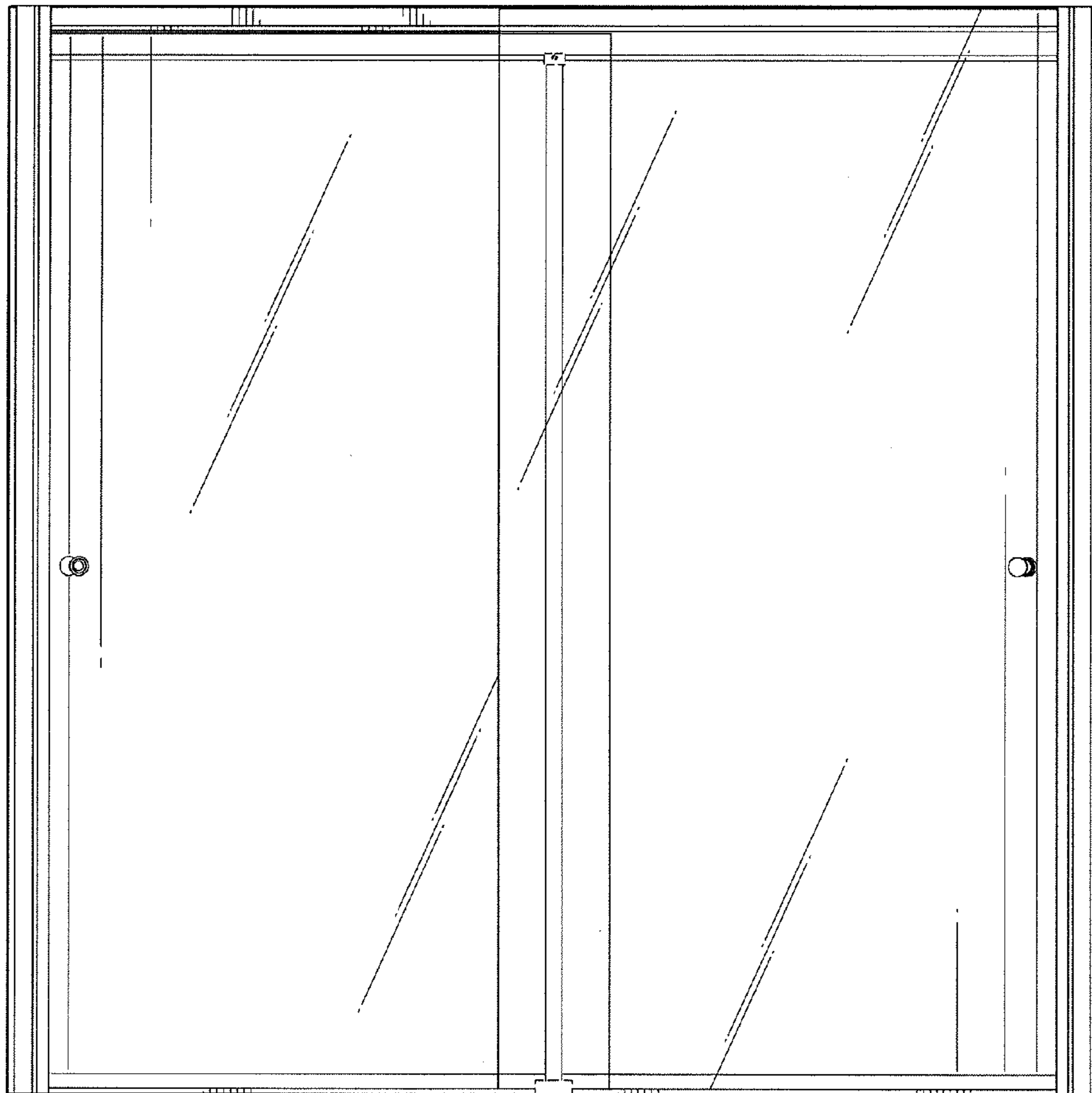

FIG.34

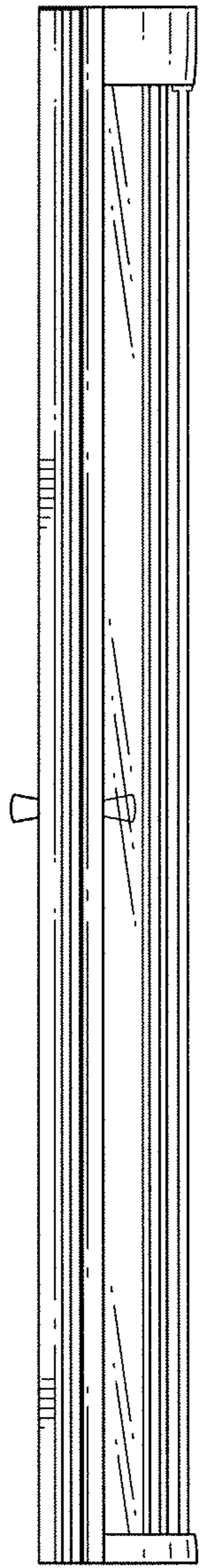

FIG. 35

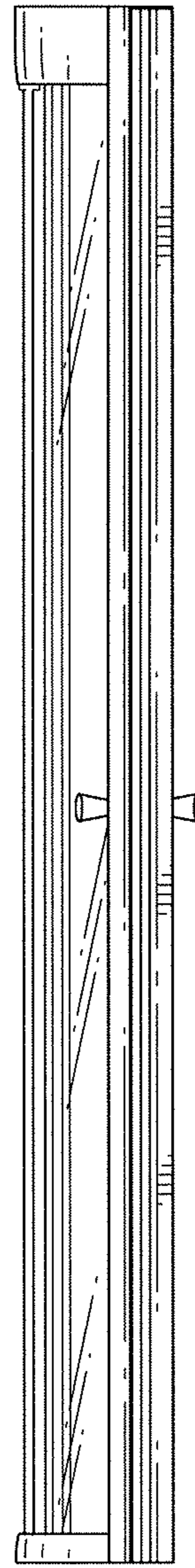

FIG. 36

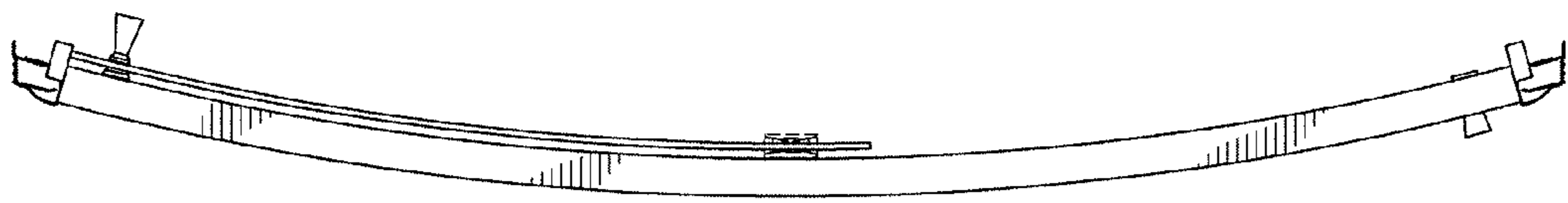

FIG. 37

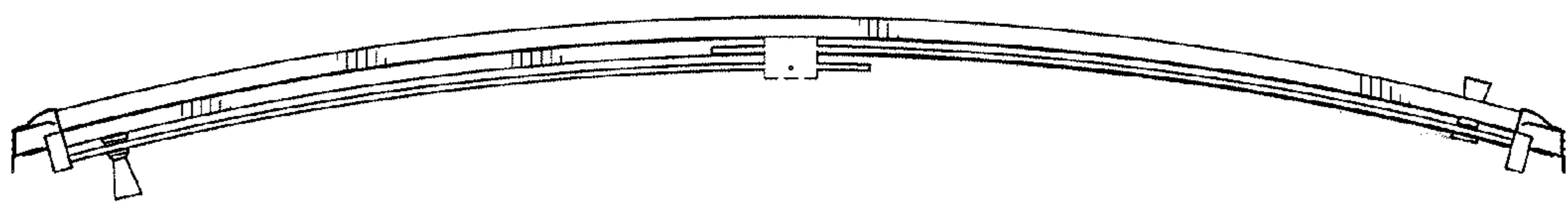

FIG. 38