



US00D727852S

(12) **United States Design Patent**
Buck et al.

(10) **Patent No.:** **US D727,852 S**
(45) **Date of Patent:** **** Apr. 28, 2015**

(54) **GROUND SHIELD FOR A RIGHT ANGLE ELECTRICAL CONNECTOR**

(75) Inventors: **Jonathan E. Buck**, Hershey, PA (US);
Stuart C. Stoner, Lewisberry, PA (US);
Steven E. Minich, York, PA (US);
Douglas M. Johnescu, York, PA (US);
Stephen B. Smith, Mechanicsburg, PA (US)

(73) Assignee: **FCI Americas Technology LLC**,
Carson City, NV (US)

(**) Term: **14 Years**

(21) Appl. No.: **29/418,299**

(22) Filed: **Apr. 13, 2012**

(51) **LOC (10) Cl.** **13-03**

(52) **U.S. Cl.**
USPC **D13/154**

(58) **Field of Classification Search**
USPC D13/146, 147, 149, 154, 184, 199;
439/74, 108, 180, 252, 246, 258, 278,
439/374, 378, 379, 381, 527, 529, 533, 660,
439/717, 865-894, 953; 174/16.3; 257/697,
257/727; 361/769

See application file for complete search history.

(56) **References Cited**

U.S. PATENT DOCUMENTS

318,186 A 5/1885 Hertzog
1,477,527 A 12/1923 Raettig

(Continued)

FOREIGN PATENT DOCUMENTS

DE 1665181 4/1974
DE 3529218 2/1986

(Continued)

OTHER PUBLICATIONS

International Patent Application No. PCT/US2013/035915: International Search Report dated Jul. 25, 2013, 17 pages.

(Continued)

Primary Examiner — Daniel Bui

(74) *Attorney, Agent, or Firm* — Baker & Hostetler LLP

(57) **CLAIM**

The ornamental design for a ground shield for a right angle electrical connector, as shown and described.

DESCRIPTION

In a preferred embodiment, the nature of this product is an electrical component that can take the form of a ground shield for a right angle electrical connector.

FIG. 1 is a top, left, front perspective view of a first embodiment of a ground shield for a right angle electrical connector showing our new design;

FIG. 2 is a bottom, right, rear perspective view thereof;

FIG. 3 is a top, front, left perspective view thereof;

FIG. 4 is a front elevation view thereof;

FIG. 5 is a rear elevation view thereof;

FIG. 6 is a top plan view thereof;

FIG. 7 is a bottom plan view thereof;

FIG. 8 is a left side elevation view thereof;

FIG. 9 is a right side elevation view thereof;

FIG. 10 is a top, left, front perspective view of a second embodiment of a ground shield for a right angle electrical connector showing our new design;

FIG. 11 is a bottom, right, rear perspective view thereof;

FIG. 12 is a top, rear, left perspective view thereof;

FIG. 13 is a front elevation view thereof;

FIG. 14 is a rear elevation view thereof;

FIG. 15 is a top plan view thereof;

FIG. 16 is a bottom plan view thereof;

FIG. 17 is a left side elevation view thereof; and,

FIG. 18 is a right side elevation view thereof.

The broken line in the drawing is for the purpose of illustrating unclaimed environment only and forms no part of the claimed design.

1 Claim, 10 Drawing Sheets

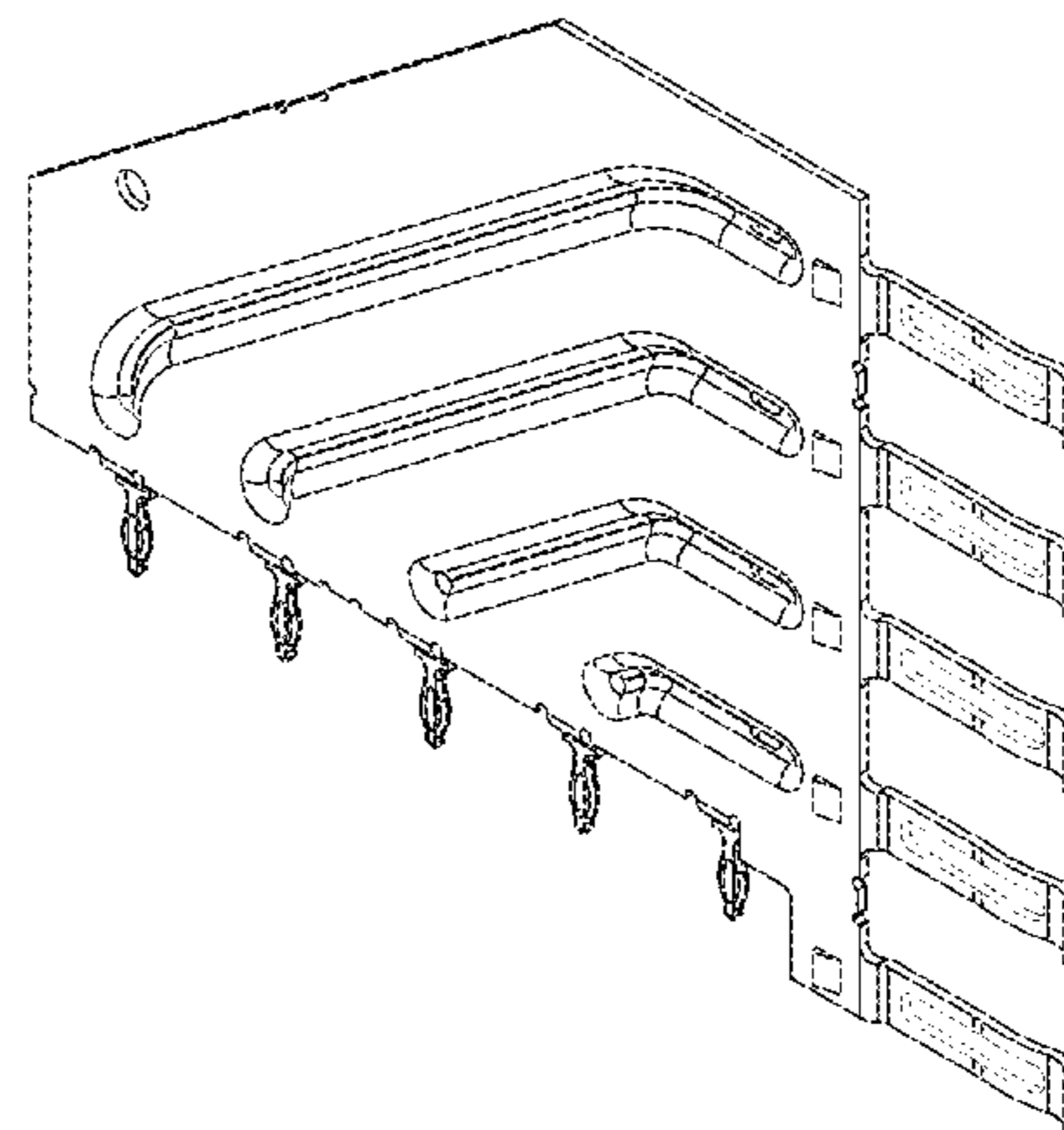
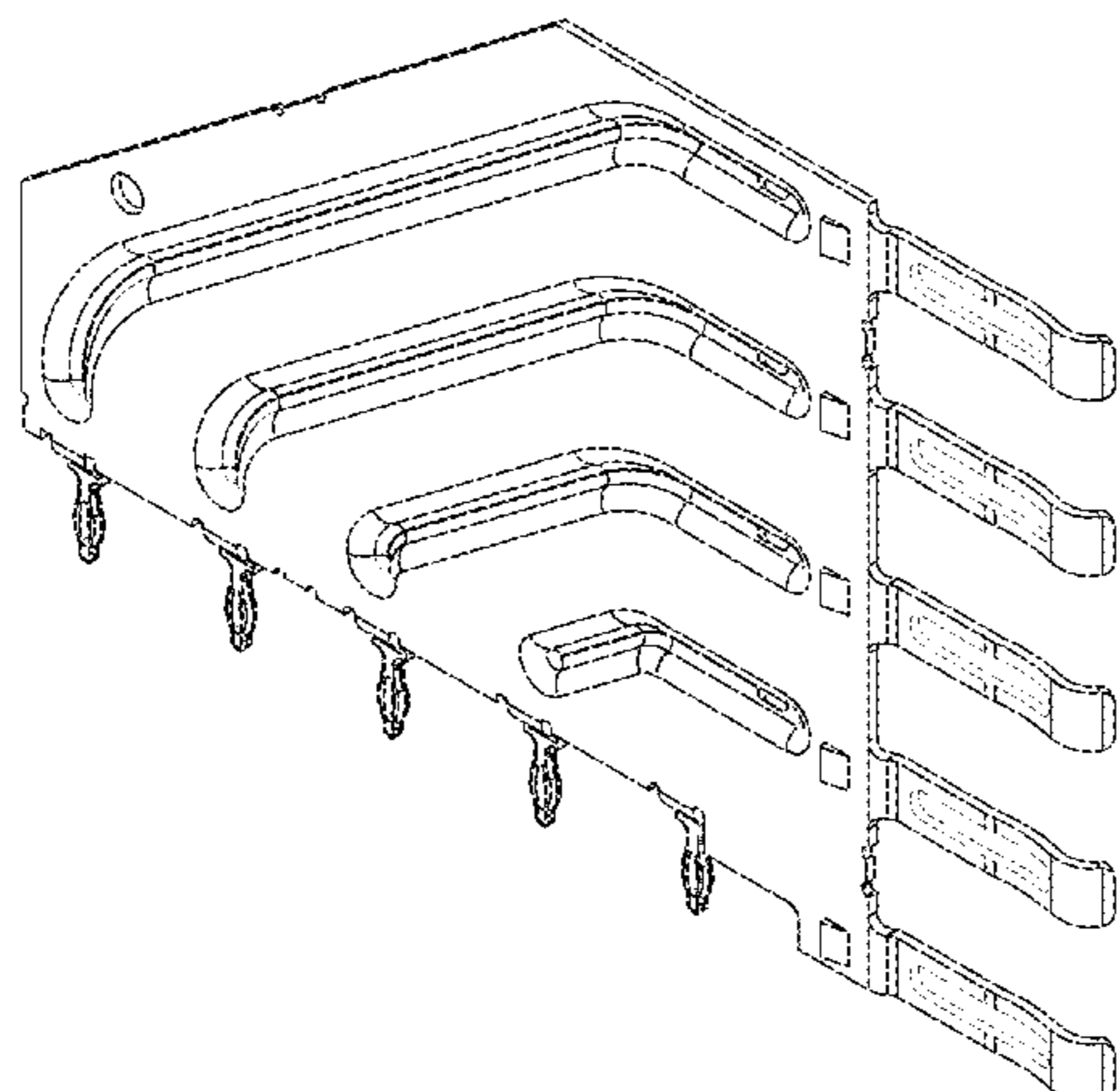

(56)

References Cited

U.S. PATENT DOCUMENTS

D86,515 S	3/1932	Cox	4,533,187 A	8/1985	Kirkman
2,231,347 A	2/1941	Reutter	4,536,955 A	8/1985	Gudgeon
2,248,675 A	7/1941	Huppert	4,545,610 A	10/1985	Lakritz et al.
2,430,011 A	11/1947	Gillentine	4,552,425 A	11/1985	Billman
2,664,552 A	12/1953	Ericsson et al.	4,560,222 A	12/1985	Dambach
2,759,163 A	8/1956	Ustin et al.	4,564,259 A	1/1986	Vandame
2,762,022 A	9/1956	Benander et al.	4,592,846 A	6/1986	Metzger et al.
2,849,700 A	4/1958	Perkin	4,596,428 A	6/1986	Tengler
2,844,644 A	7/1958	Soule, Jr.	4,596,433 A	6/1986	Oesterheld et al.
2,858,372 A	10/1958	Kaufman	4,624,604 A	11/1986	Wagner et al.
3,011,143 A	11/1961	Dean	4,632,476 A	12/1986	Schell
3,115,379 A	12/1963	McKee	4,641,426 A	2/1987	Hartman et al.
3,178,669 A	4/1965	Roberts	4,655,515 A	4/1987	Hamsher, Jr. et al.
3,179,738 A	4/1965	Lyon	4,664,309 A	5/1987	Allen et al.
3,208,030 A	9/1965	Evans et al.	4,664,456 A	5/1987	Blair et al.
3,286,220 A	11/1966	Marley et al.	4,664,458 A	5/1987	Worth
3,320,658 A	5/1967	Bolda et al.	4,678,250 A	7/1987	Romine et al.
3,343,120 A	9/1967	Whiting	4,685,886 A	8/1987	Denlinger et al.
3,366,729 A	1/1968	Pauza	4,705,205 A	11/1987	Allen et al.
3,411,127 A	11/1968	Adams	4,705,332 A	11/1987	Sadigh-Behzadi
3,420,087 A	1/1969	Hatfield et al.	4,717,360 A	1/1988	Czaja
D213,697 S	4/1969	Oxley	4,722,470 A	2/1988	Johary
3,482,201 A	12/1969	Schneck	4,762,500 A	8/1988	Dola et al.
3,514,740 A	5/1970	Filson et al.	4,767,344 A	8/1988	Noschese
3,538,486 A	11/1970	Shlesinger, Jr.	4,776,803 A	10/1988	Pretchel et al.
3,560,908 A	2/1971	Dell et al.	4,782,893 A	11/1988	Thomas
3,591,834 A	7/1971	Kolias	4,790,763 A	12/1988	Weber et al.
3,634,811 A	1/1972	Teagno	4,806,107 A	2/1989	Arnold et al.
3,641,475 A	2/1972	Irish et al.	4,815,987 A	3/1989	Kawano et al.
3,663,925 A	5/1972	Proctor	4,818,237 A	4/1989	Weber
3,669,054 A	6/1972	Desso et al.	4,820,169 A	4/1989	Weber et al.
3,692,994 A	9/1972	Hirschman et al.	4,820,182 A	4/1989	Harwath et al.
3,701,076 A	10/1972	Irish	4,824,383 A	4/1989	Lemke
3,719,981 A	3/1973	Steitz	4,830,264 A	5/1989	Bitailou et al.
3,732,697 A	5/1973	Dickson	4,836,791 A	6/1989	Grabbe et al.
3,748,633 A	7/1973	Lundergan	4,844,813 A	7/1989	Helfgott et al.
3,827,005 A	7/1974	Friend	4,846,727 A	7/1989	Glover et al.
3,845,451 A	10/1974	Neidecker	4,850,887 A	7/1989	Sugawara
3,864,004 A	2/1975	Friend	4,854,899 A	8/1989	Matthews
3,865,462 A	2/1975	Cobaugh et al.	4,867,713 A	9/1989	Ozu et al.
3,867,008 A	2/1975	Gartland, Jr.	4,871,110 A	10/1989	Fukasawa et al.
3,871,015 A	3/1975	Lin et al.	4,878,611 A	11/1989	LoVasco et al.
3,889,364 A	6/1975	Krueger	4,881,905 A	11/1989	Demler et al.
3,942,856 A	3/1976	Mindheim et al.	4,882,554 A	11/1989	Akaba et al.
3,972,580 A	8/1976	Pemberton et al.	4,884,335 A	12/1989	McCoy et al.
4,030,792 A	6/1977	Fuerst	4,898,539 A	2/1990	Glover et al.
4,056,302 A	11/1977	Braun et al.	4,900,271 A	2/1990	Colleran et al.
4,070,088 A	1/1978	Vaden	4,904,212 A	2/1990	Durbin et al.
4,076,362 A	2/1978	Ichimura	4,907,990 A	3/1990	Bertho et al.
4,082,407 A	4/1978	Smorzaniuk et al.	4,908,129 A	3/1990	Finsterwalder et al.
4,097,266 A	6/1978	Takahashi et al.	4,913,664 A	4/1990	Dixon et al.
4,136,919 A	1/1979	Howard et al.	4,915,641 A	4/1990	Miskin et al.
4,140,361 A	2/1979	Sochor	4,917,616 A	4/1990	Demler, Jr. et al.
4,159,861 A	7/1979	Anhalt	4,952,172 A	8/1990	Barkus et al.
4,217,024 A	8/1980	Aldridge et al.	4,963,102 A	10/1990	Gettig et al.
4,232,924 A	11/1980	Kline et al.	4,965,699 A	10/1990	Jordan et al.
4,260,212 A	4/1981	Ritchie et al.	4,973,257 A	11/1990	Lhotak
4,274,700 A	6/1981	Keglewitsch et al.	4,973,271 A	11/1990	Ishizuka et al.
4,288,139 A	9/1981	Cobaugh et al.	4,974,119 A	11/1990	Martin
4,371,912 A	2/1983	Guzik	4,975,069 A	12/1990	Fedder et al.
4,380,518 A	4/1983	Wydro, Sr.	4,975,084 A	12/1990	Fedder et al.
4,383,724 A	5/1983	Verhoeven	4,979,074 A	12/1990	Morley et al.
4,395,086 A	7/1983	Marsh	4,997,390 A	3/1991	Scholz et al.
4,396,140 A	8/1983	Jaffe et al.	5,004,426 A	4/1991	Barnett
4,402,563 A	9/1983	Sinclair	5,016,968 A	5/1991	Hammond et al.
4,403,821 A	9/1983	Zimmerman et al.	5,024,372 A	6/1991	Altman et al.
4,448,467 A	5/1984	Weidler	5,024,610 A	6/1991	French et al.
4,462,534 A	7/1984	Bitailou et al.	5,035,631 A	7/1991	Piorunneck et al.
4,464,003 A	8/1984	Goodman et al.	5,035,639 A	7/1991	Kilpatrick et al.
4,473,113 A	9/1984	Whitfield et al.	5,046,960 A	9/1991	Fedder et al.
4,473,477 A	9/1984	Beall	5,052,953 A	10/1991	Weber
D275,849 S	10/1984	Sakurai	5,055,054 A	10/1991	Doutrich
4,482,937 A	11/1984	Berg	5,060,844 A	10/1991	Behun et al.
4,505,529 A	3/1985	Barkus	5,065,282 A	11/1991	Polonio
4,523,296 A	6/1985	Healy, Jr.	5,066,236 A	11/1991	Broeksteeg
			5,077,893 A	1/1992	Mosquera et al.
			5,082,459 A	1/1992	Billman et al.
			5,083,238 A	1/1992	Bousman
			5,093,986 A	3/1992	Mandai et al.

(56)

References Cited

U.S. PATENT DOCUMENTS

5,094,623 A	3/1992	Scharf et al.	5,429,521 A	7/1995	Morlion et al.
5,094,634 A	3/1992	Dixon et al.	5,431,332 A	7/1995	Kirby et al.
5,098,311 A	3/1992	Roath et al.	5,431,578 A	7/1995	Wayne
5,104,332 A	4/1992	McCoy	5,433,617 A	7/1995	Morlion et al.
5,104,341 A	4/1992	Gilissen et al.	5,433,618 A	7/1995	Morlion et al.
5,111,991 A	5/1992	Clawson et al.	5,435,482 A	7/1995	Variot et al.
5,117,331 A	5/1992	Gebara	5,442,852 A	8/1995	Danner
5,118,027 A	6/1992	Braun et al.	5,445,313 A	8/1995	Boyd et al.
5,120,237 A	6/1992	Fussell	5,457,342 A	10/1995	Herbst, II
5,127,839 A	7/1992	Korsunsky et al.	5,458,426 A	10/1995	Ito
5,131,871 A	7/1992	Banakis et al.	5,462,456 A	10/1995	Howell
5,137,959 A	8/1992	Block et al.	5,467,913 A	11/1995	Namekawa et al.
5,139,426 A	8/1992	Barkus et al.	5,474,472 A	12/1995	Niwa et al.
5,145,104 A	9/1992	Apap et al.	5,475,922 A	12/1995	Tamura et al.
5,151,056 A	9/1992	McClune	5,477,933 A	12/1995	Nguyen
5,152,700 A	10/1992	Bogursky et al.	5,489,750 A	2/1996	Sakemi et al.
5,161,987 A	11/1992	Sinisi	5,490,040 A	2/1996	Gaudenzi et al.
5,163,337 A	11/1992	Herron et al.	5,491,303 A	2/1996	Weiss
5,163,849 A	11/1992	Fogg et al.	5,492,266 A	2/1996	Hoebener et al.
5,167,528 A	12/1992	Nishiyama et al.	5,495,668 A	3/1996	Furusawa et al.
5,169,337 A	12/1992	Ortega et al.	5,496,183 A	3/1996	Soes et al.
5,174,770 A	12/1992	Sasaki et al.	5,498,167 A	3/1996	Seto et al.
5,181,855 A	1/1993	Mosquera et al.	5,499,487 A	3/1996	McGill
5,194,480 A	3/1993	Block et al.	5,504,277 A	4/1996	Danner
5,199,885 A	4/1993	Korsunsky et al.	5,511,987 A	4/1996	Shinchi
5,203,075 A	4/1993	Angulas et al.	5,512,519 A	4/1996	Hwang
5,207,372 A	5/1993	Funari et al.	5,516,030 A	5/1996	Denton
5,213,868 A	5/1993	Liberty et al.	5,516,032 A	5/1996	Sakemi et al.
5,214,308 A	5/1993	Nishiguchi	5,518,410 A	5/1996	Masami
5,217,381 A	6/1993	Zell et al.	5,519,580 A	5/1996	Natarajan et al.
5,222,649 A	6/1993	Funari et al.	5,522,727 A	6/1996	Saito et al.
5,224,867 A	7/1993	Ohtsuki et al.	5,533,915 A	7/1996	Deans
5,228,864 A	7/1993	Fusselman et al.	5,534,127 A	7/1996	Sakai
5,229,016 A	7/1993	Hayes et al.	5,539,153 A	7/1996	Schwiebert et al.
5,238,414 A	8/1993	Yaegashi et al.	5,542,174 A	8/1996	Chiu
5,254,012 A	10/1993	Wang	5,542,174 A	8/1996	Chiu
5,255,839 A	10/1993	Da Costa Alves et al.	5,542,174 A	8/1996	Chiu
5,257,941 A	11/1993	Lwee et al.	5,558,542 A	9/1996	O'Sullivan et al.
5,261,155 A	11/1993	Angulas et al.	5,564,952 A	10/1996	Davis et al.
5,269,453 A	12/1993	Melton et al.	5,575,688 A	11/1996	Crane, Jr.
5,274,918 A	1/1994	Reed	5,577,928 A	11/1996	Duclos
5,275,330 A	1/1994	Isaacs et al.	5,580,283 A	12/1996	O'Sullivan et al.
5,276,964 A	1/1994	Anderson, Jr. et al.	5,586,908 A	12/1996	Lorrain
5,277,624 A	1/1994	Champion et al.	5,586,914 A	12/1996	Foster, Jr. et al.
5,284,287 A	2/1994	Wilson et al.	5,588,859 A	12/1996	Maurice
5,285,163 A	2/1994	Liotta	5,590,463 A	1/1997	Feldman et al.
5,286,212 A	2/1994	Broeksteeg	5,591,118 A	1/1997	Bierck
5,288,949 A	2/1994	Crafts	5,591,941 A	1/1997	Acocella et al.
5,295,843 A	3/1994	Davis et al.	5,593,322 A	1/1997	Swamy et al.
5,298,791 A	3/1994	Liberty et al.	5,605,417 A	2/1997	Englert et al.
5,302,135 A	4/1994	Lee	5,609,502 A	3/1997	Thumma
5,321,582 A	6/1994	Casperson	5,613,882 A	3/1997	Hnatuck et al.
5,324,569 A	6/1994	Nagesh et al.	5,618,187 A	4/1997	Goto
5,342,211 A	8/1994	Broeksteeg	5,634,821 A	6/1997	Crane, Jr.
5,344,327 A	9/1994	Brunker et al.	5,637,008 A	6/1997	Kozel
5,346,118 A	9/1994	Degani et al.	5,637,019 A	6/1997	Crane, Jr. et al.
5,354,219 A	10/1994	Wanjura	5,643,009 A	7/1997	Dinkel et al.
5,355,283 A	10/1994	Marrs et al.	5,664,968 A	9/1997	Micklevicz
5,356,300 A	10/1994	Costello et al.	5,664,973 A	9/1997	Emmert et al.
5,356,301 A	10/1994	Champion et al.	5,667,392 A	9/1997	Kocher et al.
5,357,050 A	10/1994	Baran et al.	5,672,064 A	9/1997	Provencher et al.
5,358,417 A	10/1994	Schmedding	5,691,041 A	11/1997	Frankeny et al.
5,377,902 A	1/1995	Hayes	5,691,041 A	11/1997	Frankeny et al.
5,381,314 A	1/1995	Rudy, Jr. et al.	D387,733 S	12/1997	Lee
5,382,168 A	1/1995	Azuma et al.	5,697,799 A	12/1997	Consoli et al.
D355,409 S	2/1995	Krokaugger	5,702,255 A	12/1997	Murphy et al.
5,387,111 A	2/1995	DeSantis et al.	5,713,746 A	2/1998	Olson et al.
5,387,139 A	2/1995	McKee et al.	5,718,606 A	2/1998	Rigby et al.
5,395,250 A	3/1995	Englert, Jr. et al.	5,727,963 A	3/1998	LeMaster
5,400,949 A	3/1995	Hirvonen et al.	5,730,609 A	3/1998	Harwath
5,403,206 A	4/1995	McNamara et al.	5,733,453 A	3/1998	DeBusk
5,409,157 A	4/1995	Nagesh et al.	5,741,144 A	4/1998	Elco et al.
5,410,807 A	5/1995	Bross et al.	5,741,161 A	4/1998	Cahaly et al.
5,427,543 A	6/1995	Dynia	5,742,484 A	4/1998	Gillette et al.
5,429,520 A	7/1995	Morlion et al.	5,743,009 A	4/1998	Matsui et al.
			5,743,765 A	4/1998	Andrews et al.
			5,745,349 A	4/1998	Lemke
			5,746,608 A	5/1998	Taylor
			5,749,746 A	5/1998	Tan et al.
			5,755,595 A	5/1998	Davis et al.
			5,766,023 A	6/1998	Noschese et al.
			5,772,451 A	6/1998	Dozier, II et al.

(56)

References Cited

U.S. PATENT DOCUMENTS

5,782,644 A	7/1998	Kiat	6,152,747 A	11/2000	McNamara
5,787,971 A	8/1998	Dodson	6,152,756 A	11/2000	Huang et al.
5,795,191 A	8/1998	Preputnick et al.	6,154,742 A	11/2000	Herriot
5,810,607 A	9/1998	Shih et al.	6,171,115 B1	1/2001	Mickiewicz et al.
5,817,973 A	10/1998	Elco et al.	6,171,149 B1	1/2001	Van Zanten
5,827,094 A	10/1998	Aizawa et al.	6,174,198 B1	1/2001	Wu et al.
5,831,314 A	11/1998	Wen	6,179,663 B1	1/2001	Bradley et al.
5,833,475 A	11/1998	Mitra	6,180,891 B1	1/2001	Murdeshwar
5,846,024 A	12/1998	Mao et al.	6,183,287 B1	2/2001	Po
5,851,121 A	12/1998	Thenaisie et al.	6,183,301 B1	2/2001	Paagman
5,853,797 A	12/1998	Fuchs et al.	6,190,213 B1	2/2001	Reichart et al.
5,857,857 A	1/1999	Fukuda	6,193,537 B1	2/2001	Harper, Jr. et al.
5,860,816 A	1/1999	Provencher et al.	6,196,871 B1	3/2001	Szu
5,871,362 A	2/1999	Campbell et al.	6,202,916 B1	3/2001	Updike et al.
5,874,776 A	2/1999	Kresge et al.	6,206,722 B1	3/2001	Ko et al.
5,876,219 A	3/1999	Taylor	6,206,735 B1	3/2001	Zanolli
5,876,222 A	3/1999	Gardner et al.	6,210,197 B1	4/2001	Yu
5,876,248 A	3/1999	Brunker et al.	6,210,240 B1	4/2001	Comerci et al.
5,882,214 A	3/1999	Hillbish et al.	6,212,755 B1	4/2001	Shimada et al.
5,883,782 A	3/1999	Thurston et al.	6,215,180 B1	4/2001	Chen et al.
5,887,158 A	3/1999	Sample et al.	6,219,913 B1	4/2001	Uchiyama
5,888,884 A	3/1999	Wojnarowski	6,220,884 B1	4/2001	Lin
5,892,791 A	4/1999	Moon	6,220,895 B1	4/2001	Lin
5,893,761 A	4/1999	Longueville	6,220,896 B1	4/2001	Bertoncini et al.
5,902,136 A	5/1999	Lemke et al.	6,227,882 B1	5/2001	Ortega et al.
5,904,581 A	5/1999	Pope et al.	6,231,391 B1	5/2001	Ramey et al.
5,913,702 A	6/1999	Garcin	6,234,851 B1	5/2001	Phillips
5,919,050 A	7/1999	Kehley et al.	6,238,225 B1	5/2001	Middlehurst et al.
5,930,114 A	7/1999	Kuzmin et al.	6,241,535 B1	6/2001	Lemke et al.
5,938,479 A	8/1999	Paulson et al.	6,244,887 B1	6/2001	Commerci et al.
5,943,770 A	8/1999	Thenaisie et al.	6,257,478 B1	7/2001	Straub
5,955,888 A	9/1999	Frederickson et al.	6,259,039 B1	7/2001	Chronos, Jr. et al.
5,961,355 A	10/1999	Morlion et al.	6,261,132 B1	7/2001	Koseki et al.
5,967,844 A	10/1999	Doutrich et al.	6,267,604 B1	7/2001	Mickiewicz et al.
5,971,817 A	10/1999	Longueville	6,269,539 B1	8/2001	Takahashi et al.
5,975,921 A	11/1999	Shuey	6,274,474 B1	8/2001	Caletka et al.
5,980,270 A	11/1999	Fjelstad et al.	6,280,209 B1	8/2001	Bassler et al.
5,980,321 A	11/1999	Cohen et al.	6,280,230 B1	8/2001	Takase et al.
5,982,249 A	11/1999	Bruns	6,280,809 B1	8/2001	Wang
5,984,690 A	11/1999	Riechelmann et al.	6,290,552 B1	9/2001	Saito et al.
5,984,726 A	11/1999	Wu	6,293,827 B1	9/2001	Stokoe et al.
5,992,953 A	11/1999	Rabinovitz	6,299,483 B1	10/2001	Cohen et al.
5,993,259 A	11/1999	Stokoe et al.	6,299,484 B2	10/2001	Van Woensel et al.
6,012,948 A	1/2000	Wu	6,299,492 B1	10/2001	Pierini et al.
6,022,227 A	2/2000	Huang	6,302,711 B1	10/2001	Ito
6,024,584 A	2/2000	Lemke et al.	6,309,245 B1	10/2001	Sweeney
6,027,381 A	2/2000	Lok	6,319,075 B1	11/2001	Clark et al.
6,036,549 A	3/2000	Wulff	6,322,377 B2	11/2001	Middlehurst et al.
6,041,498 A	3/2000	Hillbish et al.	6,322,379 B1	11/2001	Ortega et al.
6,042,389 A	3/2000	Lemke et al.	6,322,393 B1	11/2001	Doutrich et al.
6,042,394 A	3/2000	Mitra et al.	6,328,602 B1	12/2001	Yamasaki et al.
6,042,427 A	3/2000	Adriaenssens et al.	6,338,635 B1	1/2002	Lee
6,050,842 A	4/2000	Ferrill et al.	6,343,955 B2	2/2002	Billman et al.
6,050,862 A	4/2000	Ishii	6,347,952 B1	2/2002	Hasegawa et al.
6,053,751 A	4/2000	Humphrey	6,347,962 B1	2/2002	Kline
6,059,170 A	5/2000	Jimarez et al.	6,350,134 B1	2/2002	Fogg et al.
6,066,048 A	5/2000	Lees	6,354,877 B1	3/2002	Shuey et al.
6,068,520 A	5/2000	Winings et al.	6,358,061 B1	3/2002	Regnier
6,071,152 A	6/2000	Achammer et al.	6,359,783 B1	3/2002	Noble
6,077,130 A	6/2000	Hughes et al.	6,360,940 B1	3/2002	Bolde et al.
6,083,047 A	7/2000	Paagman	6,361,366 B1	3/2002	Shuey et al.
6,086,386 A	7/2000	Fjelstad et al.	6,361,376 B1	3/2002	Onoda
6,089,878 A	7/2000	Meng	6,362,961 B1	3/2002	Chiou
6,095,827 A	8/2000	Dutkowsky et al.	6,363,607 B1	4/2002	Chen et al.
6,113,418 A	9/2000	Kjeldahl	6,364,710 B1	4/2002	Billman et al.
6,116,926 A	9/2000	Ortega et al.	6,371,773 B1	4/2002	Crofoot et al.
6,116,965 A	9/2000	Arnett et al.	6,371,813 B2	4/2002	Ramey et al.
6,123,554 A	9/2000	Ortega et al.	6,375,478 B1	4/2002	Kikuchi
6,125,535 A	10/2000	Chiou et al.	6,375,508 B1	4/2002	Pickles et al.
6,129,592 A	10/2000	Mickiewicz et al.	6,379,188 B1	4/2002	Cohen et al.
6,132,255 A	10/2000	Verhoeven	6,386,914 B1	5/2002	Collins et al.
6,139,336 A	10/2000	Olson	6,386,924 B2	5/2002	Long
6,146,157 A	11/2000	Lenoir et al.	6,390,826 B1	5/2002	Affolter et al.
6,146,202 A	11/2000	Ramey et al.	6,394,818 B1	5/2002	Smalley, Jr.
6,146,203 A	11/2000	Elco et al.	6,402,566 B1	6/2002	Middlehurst et al.
			6,409,543 B1	6/2002	Astbury, Jr. et al.
			6,414,248 B1	7/2002	Sundstrom
			6,420,778 B1	7/2002	Sinyansky
			6,428,328 B2	8/2002	Haba et al.

(56)

References Cited

U.S. PATENT DOCUMENTS

6,431,914 B1	8/2002	Billman	6,726,492 B1	4/2004	Yu
6,431,921 B2	8/2002	Saito et al.	6,736,664 B2	5/2004	Ueda et al.
6,435,914 B1	8/2002	Billman	6,739,910 B1	5/2004	Wu
6,450,829 B1	9/2002	Weisz-Margulescu	6,740,820 B2	5/2004	Cheng
6,457,983 B1	10/2002	Bassler et al.	D492,295 S	6/2004	Glatt
6,461,183 B1	10/2002	Ohkita et al.	6,743,037 B2	6/2004	Kassa et al.
6,461,202 B2	10/2002	Kline	6,743,059 B1	6/2004	Korsunsky et al.
6,464,529 B1	10/2002	Jensen et al.	6,746,278 B2	6/2004	Nelson et al.
6,471,523 B1	10/2002	Shuey	6,749,439 B1	6/2004	Potter et al.
6,471,548 B2	10/2002	Bertoncini et al.	6,762,067 B1	7/2004	Quinones et al.
6,472,474 B2	10/2002	Burkhardt et al.	6,764,341 B2	7/2004	Lappoehn
6,482,038 B2	11/2002	Olson	6,769,883 B2	8/2004	Brid et al.
6,485,330 B1	11/2002	Doutrich	6,769,935 B2	8/2004	Stokoe et al.
6,488,549 B1	12/2002	Weller et al.	6,776,635 B2	8/2004	Blanchfield et al.
6,489,567 B2	12/2002	Zachrai	6,776,649 B2	8/2004	Pape et al.
6,491,545 B1	12/2002	Spiegel et al.	6,780,027 B2	8/2004	Allison et al.
6,494,734 B1	12/2002	Shuey	6,786,771 B2	9/2004	Gailus
6,503,103 B1	1/2003	Cohen et al.	6,790,088 B2	9/2004	Ono et al.
6,506,076 B2	1/2003	Cohen et al.	6,796,831 B1	9/2004	Yasufuku et al.
6,506,081 B2	1/2003	Blanchfield et al.	6,797,215 B2	9/2004	Bonk et al.
6,514,103 B2	2/2003	Pape et al.	D497,343 S *	10/2004	Busse et al. D13/147
6,517,360 B1	2/2003	Cohen	6,805,278 B1	10/2004	Olson et al.
6,520,803 B1	2/2003	Dunn	6,808,399 B2	10/2004	Rothermel et al.
6,526,519 B1	2/2003	Cuthbert	6,808,420 B2	10/2004	Whiteman, Jr. et al.
6,527,587 B1	3/2003	Ortega et al.	6,810,783 B1	11/2004	Larose
6,527,588 B2	3/2003	Paagman	6,811,440 B1	11/2004	Rothermel et al.
6,528,737 B1	3/2003	Kwong et al.	6,814,590 B2	11/2004	Minich et al.
6,530,134 B1	3/2003	Laphan et al.	6,814,619 B1	11/2004	Stokoe et al.
6,537,086 B1	3/2003	Mac Mullin	6,824,391 B2	11/2004	Mickievicz et al.
6,537,111 B2	3/2003	Brammer et al.	6,829,143 B2	12/2004	Russell et al.
6,540,522 B2	4/2003	Sipe	6,835,072 B2	12/2004	Simons et al.
6,540,558 B1	4/2003	Paagman	6,835,103 B2	12/2004	Middlehurst et al.
6,540,559 B1	4/2003	Kemmick et al.	6,843,686 B2	1/2005	Ohnishi et al.
6,544,046 B1	4/2003	Hahn et al.	6,843,687 B2	1/2005	McGowan et al.
6,544,072 B2	4/2003	Olson	6,848,886 B2	2/2005	Schmaling et al.
6,547,066 B2	4/2003	Koch	6,848,944 B2	2/2005	Evans
6,551,112 B1	4/2003	Li et al.	6,848,950 B2	2/2005	Allison et al.
6,551,140 B2	4/2003	Billman et al.	6,848,953 B2	2/2005	Schell et al.
6,554,647 B1	4/2003	Cohen et al.	6,851,974 B2	2/2005	Doutrich
6,565,387 B2	5/2003	Cohen	6,851,980 B2	2/2005	Nelson et al.
6,565,388 B1	5/2003	Van Woensel et al.	6,852,567 B1	2/2005	Lee et al.
6,572,409 B2	6/2003	Nitta et al.	D502,919 S	3/2005	Studnicky, III
6,572,410 B1	6/2003	Volstorf et al.	6,866,549 B2	3/2005	Kimura et al.
6,575,774 B2	6/2003	Ling et al.	6,869,292 B2	3/2005	Johnescu et al.
6,575,776 B1	6/2003	Conner et al.	6,869,294 B2	3/2005	Clark et al.
6,589,071 B1	7/2003	Lias et al.	6,872,085 B1	3/2005	Cohen et al.
6,592,381 B2	7/2003	Cohen et al.	6,884,117 B2	4/2005	Korsunsky et al.
6,602,095 B2	8/2003	Astbury, Jr. et al.	6,890,184 B2	5/2005	Doblar et al.
6,604,967 B2	8/2003	Middlehurst et al.	6,890,214 B2	5/2005	Brown et al.
6,607,402 B2	8/2003	Cohen et al.	6,890,221 B2	5/2005	Wagner
6,623,310 B1	9/2003	Billman et al.	6,893,272 B2	5/2005	Yu
741,052 A1	10/2003	Mahon	6,893,300 B2	5/2005	Zhou et al.
6,629,854 B2	10/2003	Murakami	6,893,686 B2	5/2005	Egan
6,633,490 B2	10/2003	Centola et al.	6,899,566 B2	5/2005	Kline et al.
6,641,411 B1	11/2003	Stoddard et al.	6,902,411 B2	6/2005	Kubo
6,641,825 B2	11/2003	Scholz et al.	6,905,367 B2	6/2005	Crane, Jr. et al.
6,652,318 B1	11/2003	Winings et al.	6,913,490 B2	7/2005	Whiteman, Jr. et al.
6,663,426 B2	12/2003	Hasircoglu et al.	6,918,776 B2	7/2005	Spink, Jr.
6,665,189 B1	12/2003	Lebo	6,918,789 B2	7/2005	Lang et al.
6,666,693 B2	12/2003	Belopolsky et al.	6,929,504 B2	8/2005	Ling et al.
6,669,514 B2	12/2003	Wiebking et al.	6,932,649 B1	8/2005	Rothermel et al.
6,672,884 B1	1/2004	Toh et al.	6,939,173 B1	9/2005	Elco et al.
6,672,907 B2	1/2004	Azuma	6,945,796 B2	9/2005	Bassler et al.
6,679,709 B2	1/2004	Takeuchi	6,947,012 B2	9/2005	Aisenbrey
6,692,272 B2	2/2004	Lemke et al.	6,951,466 B2	10/2005	Sandoval et al.
6,695,627 B2	2/2004	Ortega et al.	6,953,351 B2	10/2005	Fromm et al.
6,702,590 B2	3/2004	Zaderej et al.	6,969,268 B2	11/2005	Brunker
6,702,594 B2	3/2004	Lee et al.	6,969,280 B2	11/2005	Chien et al.
6,705,902 B1	3/2004	Yi et al.	6,975,511 B1	12/2005	Lebo et al.
6,709,294 B1	3/2004	Cohen et al.	6,976,886 B2	12/2005	Winings et al.
6,712,621 B2	3/2004	Li et al.	6,979,202 B2	12/2005	Benham et al.
6,712,646 B2	3/2004	Shindo	6,979,215 B2	12/2005	Avery et al.
6,716,045 B2	4/2004	Meredith	6,981,883 B2	1/2006	Raistrick et al.
6,716,068 B2	4/2004	Wu	6,988,902 B2	1/2006	Winings et al.
6,717,825 B2	4/2004	Volstorf	6,994,569 B2	2/2006	Minich et al.
			7,001,189 B1	2/2006	McGowan et al.
			7,021,975 B2	4/2006	Lappohn
			7,040,901 B2	5/2006	Benham et al.
			7,044,794 B2	5/2006	Consoli et al.

(56)

References Cited

U.S. PATENT DOCUMENTS

7,059,892 B1	6/2006	Trout	7,621,781 B2	11/2009	Rothermel et al.
7,059,919 B2	6/2006	Clark et al.	D607,822 S *	1/2010	Dennes D13/147
7,065,871 B2	6/2006	Minich et al.	D611,908 S	3/2010	Takada et al.
7,070,464 B2	7/2006	Clark et al.	7,708,569 B2	5/2010	Sercu et al.
7,074,096 B2	7/2006	Copper et al.	D618,180 S	6/2010	Gross et al.
7,086,147 B2	8/2006	Caletka et al.	D618,181 S	6/2010	Gross et al.
7,090,501 B1	8/2006	Scherer et al.	7,753,731 B2	7/2010	Cohen et al.
7,094,102 B2	8/2006	Cohen et al.	7,762,843 B2	7/2010	Minich et al.
7,097,465 B1	8/2006	Korsunsky et al.	D626,075 S *	10/2010	Truskett et al. D13/147
7,097,506 B2	8/2006	Nakada	7,833,065 B2	11/2010	Lin et al.
7,101,191 B2	9/2006	Benham et al.	D628,963 S *	12/2010	Sau et al. D13/147
7,101,228 B2	9/2006	Hammer et al.	7,976,326 B2	7/2011	Stoner
7,104,812 B1	9/2006	Bogiel et al.	7,988,456 B2	8/2011	Davis et al.
7,108,556 B2	9/2006	Cohen et al.	D651,177 S	12/2011	Luo
7,114,963 B2	10/2006	Shuey et al.	8,079,847 B2	12/2011	Davis et al.
7,114,964 B2	10/2006	Winings et al.	D653,621 S	2/2012	Gross et al.
7,118,391 B2	10/2006	Minich et al.	8,109,770 B2	2/2012	Perugini et al.
RE39,380 E	11/2006	Davis	8,157,599 B2	4/2012	Wei
7,131,870 B2	11/2006	Whiteman, Jr. et al.	8,231,415 B2	7/2012	Johnescu et al.
7,137,848 B1	11/2006	Trout et al.	8,277,241 B2	10/2012	Horchler et al.
7,153,162 B2	12/2006	Mizumura et al.	8,366,485 B2	2/2013	Johnescu
7,160,151 B1	1/2007	Rigby et al.	8,408,939 B2	4/2013	Davis et al.
7,163,421 B1	1/2007	Cohen et al.	8,414,199 B2	4/2013	Ishigami
7,168,963 B2	1/2007	Minich et al.	8,465,213 B2	6/2013	Tamura et al.
7,172,461 B2	2/2007	Davis et al.	8,480,413 B2	7/2013	Minich et al.
7,182,642 B2	2/2007	Ngo et al.	RE44,556 E	10/2013	Minich
7,182,643 B2	2/2007	Winings et al.	2001/0003685 A1	6/2001	Aritani
D540,258 S	4/2007	Peng et al.	2001/0008189 A1	7/2001	Reede
7,204,699 B2	4/2007	Stoner	2001/0012729 A1	8/2001	Van Woensel
7,207,807 B2	4/2007	Fogg	2001/0041477 A1	11/2001	Billman et al.
D541,748 S	5/2007	Peng et al.	2001/0046810 A1	11/2001	Cohen et al.
D542,736 S	5/2007	Riku	2001/0046816 A1	11/2001	Saito et al.
7,220,141 B2	5/2007	Daily et al.	2002/0013101 A1	1/2002	Long
7,239,526 B1	7/2007	Bibee	2002/0039857 A1	4/2002	Naito et al.
7,241,168 B2	7/2007	Sakurai et al.	2002/0084105 A1	7/2002	Geng et al.
7,258,562 B2	8/2007	Daily et al.	2002/0098727 A1	7/2002	McNamara et al.
D550,158 S	9/2007	Victor	2002/0106930 A1	8/2002	Pape et al.
D550,628 S	9/2007	Whiteman, Jr. et al.	2002/0106932 A1	8/2002	Holland et al.
7,267,515 B2	9/2007	Lappohn	2002/0111068 A1	8/2002	Cohen et al.
7,270,574 B1	9/2007	Ngo	2002/0127903 A1	9/2002	Billman et al.
7,273,382 B2	9/2007	Igarashi et al.	2002/0142629 A1	10/2002	Zaderej et al.
7,278,856 B2	10/2007	Minich	2002/0142676 A1	10/2002	Hosaka et al.
7,281,950 B2	10/2007	Belopolsky	2002/0159235 A1	10/2002	Miller et al.
D554,591 S	11/2007	Victor	2002/0173177 A1	11/2002	Korsunsky
7,292,055 B2	11/2007	Egitto	2002/0187688 A1	12/2002	Marvin et al.
7,303,427 B2	12/2007	Swain	2002/0193019 A1	12/2002	Blanchfield et al.
7,316,585 B2	1/2008	Smith et al.	2003/0116857 A1	6/2003	Taniguchi et al.
7,322,855 B2	1/2008	Mongold et al.	2003/0119378 A1	6/2003	Avery
7,331,802 B2	2/2008	Rothermel et al.	2003/0143894 A1	7/2003	Kline et al.
7,335,043 B2	2/2008	Hgo et al.	2003/0171010 A1	9/2003	Winings et al.
7,338,321 B2	3/2008	Laurx	2003/0203665 A1	10/2003	Ohnishi et al.
7,347,740 B2	3/2008	Minich	2003/0219999 A1	11/2003	Minich et al.
7,351,071 B2	4/2008	Korsunsky et al.	2003/0220021 A1	11/2003	Whiteman, Jr. et al.
7,381,092 B2	6/2008	Nakada	2003/0236035 A1	12/2003	Kuroda et al.
7,384,289 B2	6/2008	Minich	2004/0018757 A1	1/2004	Lang et al.
7,384,311 B2	6/2008	Sharf et al.	2004/0038590 A1	2/2004	Lang et al.
7,402,064 B2	7/2008	Daily	2004/0072470 A1	4/2004	Lang et al.
7,407,387 B2	8/2008	Johnescu	2004/0077224 A1	4/2004	Marchese
7,422,483 B2	9/2008	Avery et al.	2004/0087196 A1	5/2004	Lang et al.
7,425,145 B2	9/2008	Ngo et al.	2004/0114866 A1	6/2004	Hiramatsu
7,429,176 B2	9/2008	Johnescu	2004/0157477 A1	8/2004	Johnson et al.
7,445,457 B1	11/2008	Frangioso, Jr. et al.	2004/0224559 A1	11/2004	Nelson et al.
7,452,242 B2 *	11/2008	Poh et al. 439/636	2004/0235321 A1	11/2004	Mizumura et al.
7,452,249 B2	11/2008	Daily	2004/0259420 A1 *	12/2004	Wu 439/608
7,458,839 B2	12/2008	Ngo	2005/0009402 A1	1/2005	Chien et al.
7,467,955 B2	12/2008	Raistrick et al.	2005/0026503 A1	2/2005	Trout et al.
7,476,108 B2	1/2009	Swain	2005/0032401 A1	2/2005	Kobayashi
7,497,735 B2	3/2009	Belopolsky	2005/0048838 A1	3/2005	Korsunsky et al.
7,497,736 B2	3/2009	Minich et al.	2005/0079763 A1	4/2005	Lemke et al.
7,500,871 B2	3/2009	Minich et al.	2005/0101166 A1	5/2005	Kameyama
7,503,804 B2	3/2009	Minich	2005/0101188 A1	5/2005	Benham et al.
7,541,135 B2	6/2009	Swain	2005/0112952 A1	5/2005	Wang et al.
7,549,897 B2	6/2009	Fedder et al.	2005/0118869 A1	6/2005	Evans
7,553,182 B2	6/2009	Buck et al.	2005/0170700 A1	8/2005	Shuey et al.
7,588,463 B2	9/2009	Yamada et al.	2005/0196987 A1	9/2005	Shuey et al.
			2005/0202722 A1	9/2005	Regnier et al.
			2005/0215121 A1	9/2005	Tokunaga
			2005/0227552 A1	10/2005	Yamashita et al.
			2005/0277315 A1	12/2005	Mongold et al.

(56)

References Cited

U.S. PATENT DOCUMENTS

2005/0287869 A1 12/2005 Kenny et al.
 2006/0003620 A1 1/2006 Daily et al.
 2006/0014433 A1 1/2006 Consoli et al.
 2006/0024983 A1 2/2006 Cohen et al.
 2006/0024984 A1 2/2006 Cohen et al.
 2006/0046526 A1 3/2006 Minich
 2006/0051987 A1 3/2006 Goodman et al.
 2006/0068610 A1 3/2006 Belopolsky
 2006/0068641 A1 3/2006 Hull et al.
 2006/0073709 A1 4/2006 Reid
 2006/0116857 A1 6/2006 Sevic et al.
 2006/0121749 A1 6/2006 Fogg
 2006/0128197 A1 6/2006 McGowan et al.
 2006/0141818 A1 6/2006 Ngo
 2006/0183377 A1 8/2006 Sinsheimer
 2006/0192274 A1 8/2006 Lee et al.
 2006/0216969 A1 9/2006 Bright et al.
 2006/0228912 A1 10/2006 Morlion et al.
 2006/0232301 A1 10/2006 Morlion et al.
 2006/0281354 A1 12/2006 Ngo et al.
 2007/0004287 A1 1/2007 Marshall
 2007/0021002 A1 1/2007 Laurx et al.
 2007/0042639 A1 2/2007 Manter et al.
 2007/0071391 A1 3/2007 Mazotti et al.
 2007/0099455 A1 5/2007 Rothermel et al.
 2007/0099512 A1 5/2007 Sato
 2007/0183707 A1 8/2007 Umezawa
 2007/0183724 A1 8/2007 Sato
 2007/0190825 A1 8/2007 Shuey et al.
 2007/0202715 A1 8/2007 Daily et al.
 2007/0202747 A1 8/2007 Sharf et al.
 2007/0205774 A1 9/2007 Minich
 2007/0207641 A1 9/2007 Minich
 2007/0293084 A1 12/2007 Ngo
 2008/0032524 A1 2/2008 Lemke et al.
 2008/0045079 A1 2/2008 Minich et al.
 2008/0176453 A1 7/2008 Minich et al.
 2008/0232737 A1 9/2008 Ishigami et al.
 2008/0246555 A1 10/2008 Kirk et al.
 2008/0248670 A1 10/2008 Daily et al.
 2008/0316729 A1 12/2008 Rothermel et al.
 2009/0011643 A1 1/2009 Amlleshi et al.
 2010/0055983 A1 3/2010 Wu
 2010/0093209 A1 4/2010 Liu et al.
 2010/0197149 A1 8/2010 Davis et al.
 2010/0216342 A1 8/2010 Lin
 2010/0221959 A1 9/2010 Pan
 2010/0240233 A1 9/2010 Johnescu et al.
 2010/0291803 A1 11/2010 Kirk
 2011/0159744 A1 6/2011 Buck
 2011/0195593 A1 8/2011 McGrath et al.
 2012/0214343 A1 8/2012 Buck et al.
 2012/0289095 A1 11/2012 Kirk
 2013/0005160 A1 1/2013 Minich
 2013/0122744 A1* 5/2013 Morgan et al. 439/607.01
 2013/0149881 A1 6/2013 Johnescu et al.
 2013/0149890 A1* 6/2013 Schroll et al. 439/449
 2013/0195408 A1 8/2013 Hermeline et al.
 2013/0210246 A1* 8/2013 Davis et al. 439/65
 2013/0273756 A1 10/2013 Stoner et al.
 2013/0273781 A1 10/2013 Buck et al.
 2014/0017957 A1 1/2014 Horchler et al.

FOREIGN PATENT DOCUMENTS

DE 3605316 8/1987
 DE 4040551 4/1993
 DE 10226279 11/2003
 DE 102010005001 8/2010
 EP 0212764 3/1987
 EP 0273683 7/1988
 EP 0337634 10/1989
 EP 0442785 8/1991
 EP 0486298 5/1992

EP 0321257 4/1993
 EP 0560550 9/1993
 EP 0562691 9/1993
 EP 0591772 4/1994
 EP 0623248 11/1995
 EP 0706240 4/1996
 EP 0782220 7/1997
 EP 0789422 8/1997
 EP 0843383 5/1998
 EP 0635910 6/2000
 EP 1024556 8/2000
 EP 1111730 6/2001
 EP 0891016 10/2002
 EP 1091449 9/2004
 EP 1148587 4/2005
 GB 1162705 8/1969
 JP 57/058115 4/1982
 JP 60/072663 4/1985
 JP 02/278893 11/1990
 JP 05/021119 1/1993
 JP 05344728 12/1993
 JP 0668943 3/1994
 JP 06236788 8/1994
 JP 07114958 5/1995
 JP 07169523 7/1995
 JP 0896918 4/1996
 JP 08125379 5/1996
 JP 09199215 7/1997
 JP 11185886 7/1999
 JP 2000/003743 1/2000
 JP 2000/003744 1/2000
 JP 2000/003745 1/2000
 JP 2000/003746 1/2000
 JP 2000/228243 8/2000
 JP 2001/135388 5/2001
 JP 2001/305182 10/2001
 JP 2002/008790 1/2002
 JP 2003/217785 7/2003
 JP 2007/128706 5/2007
 KR 100517561 9/2005
 TW 576555 8/1990
 TW 546872 8/2003
 WO WO 90/16093 12/1990
 WO WO 96/38889 12/1996
 WO WO 96/42123 12/1996
 WO WO 97/20454 6/1997
 WO WO 97/43885 11/1997
 WO WO 97/44859 11/1997
 WO WO 97/45896 12/1997
 WO WO 98/15989 4/1998
 WO WO 00/16445 3/2000
 WO WO 01/29931 4/2001
 WO WO 01/39332 5/2001
 WO WO 02/058191 7/2002
 WO WO 02/101882 12/2002
 WO WO 02/103847 12/2002
 WO WO 2005/065254 7/2005
 WO WO 2006/031296 3/2006
 WO WO 2006/105535 10/2006
 WO WO 2007/064632 6/2007
 WO WO 2008/082548 7/2008
 WO WO 2008/117180 10/2008
 WO WO 2012/047619 4/2012
 WO WO 2012/174120 12/2012

OTHER PUBLICATIONS

U.S. Appl. No. 29/418,310, filed Apr. 13, 2012, Buck et al.
 U.S. Appl. No. 29/418,313, filed Apr. 13, 2012, Zerebilov et al.
 U.S. Appl. No. 29/426,921, filed Jul. 11, 2012, Horchler.
 U.S. Appl. No. 29/444,125, filed Jan. 25, 2013, Harper Jr. et al.
 U.S. Appl. No. 29/449,794, filed Mar. 15, 2013, Zerebilov et al.
 "1.0 HDMI Right Angle Header Assembly (19 Pin) Lead Free", Molex Incorporated, Jul. 20, 2004, 7 pages.
 "1.90 by 1.35mm (.075 by .053) Pitch Impact, Backplane Connector System 3 and 4 Pair, Features and Specification", Molex, www.molex.com/link/Impact.html, 2008, 5 pages.
 "4.0 UHD Connector Differential Signal Crosstalk, Reflections", 1998, p. 8-9.

(56)

References Cited

OTHER PUBLICATIONS

- Ahn et al., "A Design of the Low-Pass Filter Using the Novel Microstrip Defected Ground Structure", IEEE Transactions on Microwave Theory and Techniques, 2001, 49(1), 86-93.
- "AMP Z-Dok and Z-Dok and Connectors", Tyco Electronics/AMP, Application Specification #114-13068, Aug. 30, 2005, 17 pages.
- "AMP Z-Pack 2mm HM Connector, 2mm Centerline, Eight-Row, Right-Angle Applications", Electrical Performance Report, EPR 889065, Issued Sep. 1998, 59 pages.
- "AMP Z-Pack 2mm HM Interconnection System", 1992/1994, AMP Incorporated, 6 pages.
- "AMP Z-Pack HM-Zd Performance at Gigabit Speeds", Tyco Electronics, Report #20GC014, Rev.B., May 4, 2001, 32 pages.
- "B. Bandwidth and Rise Time Budgets, Module 1-8 Fiber Optic Telecommunications (E-XVI-2a)", http://cord.org-step_online-st1-8-st18exvi2a.htm, 2006, 1-3.
- "Backplane Connectors", <http://www.amphenol-tcs.com/products/connectors/backplane/index.html>, Amphenol TCS (ATCS), Jun. 19, 2008, 1-3.
- Berg Electronics Catalog, p. 13-96, Solder Washers, 1996, 1 page.
- "Champ Z-Dok Connector System", Tyco Electronics, Jan. 2002, 3 pages.
- Chen et al., "Characteristics of Coplanar Transmission Lines on Multilayer Substrates: Modeling and Experiments", IEEE Transactions on Microwave Theory and Techniques, Jun. 1997, 45(6), 939-945.
- Cheng et al., "Terahertz-Bandwidth Characteristics of Coplanar Transmission Lines on Low Permittivity Substrates", IEEE Transactions on Microwave Theory and Techniques, 1994, 42(12), 2399-2406.
- Chua et al., "Broadband Characterisation of CPW Transition and Transmission Line Parameters for Small Reflection Up to 100 GHz", RF and Microwave Conference, 2004, 269-271.
- "Daughtercard Hole Pattern: Signal Modules (10 & 25 positions) Connector Assembly", Customer No. C-163-5101-500, Teradyne Connection Systems, Inc., 2001, 1 page.
- Derman "Speed, Density Push Design Complexities," Electronic Engineering Times, May 1998, 2 pages.
- European Patent Application No. 12305119.5: European Search Report dated Jul. 11, 2012, 5 pages.
- European Patent Application No. 10753953.8: Extended European Search Report dated Nov. 7, 2013, 6 pages.
- "FCI's Airmax VS Connector System Honored at DesignCon 2005", <http://www.heilind.com-products-fci-airmax-vs-design.asp>, Heilind Electronics, Inc., 2005, 1 page.
- Finan, "Thermally Conductive Thermoplastics", LNP Engineering Plastics, Inc., Plastics Engineering 2000, www.4spe.org, 4 pages.
- "Framatome Connector Specification", May 10, 1999, 1 page.
- Fusi et al., "Differential Signal Transmission through Backplanes and Connectors", Electronic Packaging and Production, Mar. 1996, 27-31.
- "GbXI-Trac Backplane Connector System", www.molex.com/cgi-bin, Molex, 2007, 1-3.
- "Gig-Array Connector System, Board to Board Connectors", 2005, 4 pages.
- "Gig-Array High Speed Mezzanine Connectors 15-40 mm Board to Board", FCI Corporation, Jun. 5, 2006, 1 page.
- Goel et al., "AMP Z-Pack Interconnect System", AMP Incorporated, 1990, 9 pages.
- "HDM Separable Interface Detail", Molex, Feb. 17, 1993, 3 pages.
- "HDM Stacker Signal Integrity", http://www.teradyne.com/prods/tcs/products/connectors/mezzanine/hdm_stack/signintegrity.html, Amphenol TCS (ATCS), Feb. 2, 2006, 3 pages.
- "HDM, HDM Plus Connectors", <http://www.teradyne.com-prods-tcs-products-connectors-backplane-hdm-index.html>, Amphenol TCS, 2006, 1 page.
- "HDM/HDM Plus, 2mm, Backplane Interconnection System", Teradyne Connection Systems, 1993, 22 pages.
- Hettak et al., "Simultaneous Realization of Millimeter Wave Uniplanar Shunt Stubs and DC Block", IEEE MTT-S Digest, 1998, 809-812.
- "High Definition Multimedia Interface (HDMI)", www.molex.com, Molex, Jun. 19, 2008, 2 pages.
- "High Speed Backplane Interconnect Solutions", Tyco Electronics, 2007, 6 pages.
- "High Speed Characterization Report, SEAM-30-02.0-S-10-2", www.samtec.com, SAMTEC, 2005, 55 pages.
- "Honda High-Speed Backplane Connector NSP Series", Honda Connectors, Feb. 7, 2003, 25 pages.
- Hult, "FCI's Problem Solving Approach Changes Market, The FCI Electronics AirMax VS", http://www.connectorsupplier.com-tech_updates_FCI-Airmax_archive.htm, ConnectorSupplier.com, 2006, 1-4.
- Hunsaker, "Ventura Application Design", TB-2127, Amphenol, Aug. 25, 2005, 13 pages.
- IBM Technical Disclosure Bulletin, 1972, 14(8), 2 pages.
- IBM Technical Disclosure Bulletin, 1977, 20(2), 2 pages.
- IBM Technical Disclosure Bulletin, 1990, 32(11), 2 pages.
- "Impact 3 Pair 10 Column Signal Module", Tyco Electronics, Mar. 25, 2008, 1 page.
- "Impact 3 Pair Header Unguided Open Assembly", Tyco Electronics, Apr. 11, 2008, 1 page.
- "Impact Connector Offered by Tyco Electronic, High Speed Backplane Connector System", Tyco Electronics, Apr. 15, 2008, 12 pages.
- International Application No. PCT/US2003/014370, International Search Report dated Aug. 6, 2003, 2 pages.
- International Application No. PCT/US2010/040899, International Search Report dated Jan. 25, 2011, 2 pages.
- International Patent Application No. PCT/US2013/035775: International Search Report dated Jul. 18, 2013, 3 pages.
- International Patent Application No. PCT/US2013/035915: International Search Report and Written Opinion dated Jul. 25, 2013, 17 pages.
- International Patent Application No. PCT/US2013/049995: International Search Report dated Oct. 28, 2013, 18 pages.
- Kazmierowicz, "Profiling Your Solder Reflow Oven in Three Passes or Less", KIC Oven Profiling, Surface Mount Technology, 1990, 2 pages.
- Kazmierowicz, "The Science Behind Conveyor Oven Thermal Profiling", KIC Oven Profiling, Surface Mount Technology, 1990, 9 pages.
- Lee et al., "Characteristic of the Coplanar Waveguide to Microstrip Right-Angled Transition", Department of Electronics Engineering, 1998, 3 pages.
- Leung et al., "Low-Loss Coplanar Waveguides Interconnects on Low-Resistivity Silicon Substrate", IEEE Transactions on Components and Packaging Technologies, 2004, 27(3), 507-512.
- Lim et al., "A Spiral-Shaped Defected Ground Structure for Coplanar Waveguide", IEEE Microwave and Wireless Components Letters, 2002, 12(9), 330-332.
- "Lucent Technologies' Bell Labs and FCI Demonstrate 25gb-S Data Transmission Over Electrical Backplane Connectors", <http://www.lucent.com-press-0205-050201.bla.html>, Lucent Tech Bell Labs, Feb. 1, 2005, 1-4.
- Machac et al., "Space Leakage of Power from Uniplanar Transmission Lines", Czech Technical University, 565-568.
- Mao et al., "Characterization of Coplanar Waveguide Open End Capacitance-Theory and Experiment", IEEE Transactions on Microwave Theory and Techniques, 1994, 42(6), 1016-1024.
- "Metral 1000 Series, 5 Row Receptacle, Right Angle, Press Fit, PCB Mounted Receptacle Assembly", FCI 2001, 1 page.
- "Metral 2mm High-Speed Connectors, 1000, 2000, 3000 Series, Electrical Performance Data for Differential Applications", FCI Framatome Group, 2000, 2 pages.
- "Metral Speed & Density Extensions", FCI, Jun. 3, 1999, 1-25.
- "Mezzanine High Speed High-Density Connectors Gig-Array and Meg-Array Electrical Performance Data", FCI Corporation, 10 pages.

(56)

References Cited

OTHER PUBLICATIONS

"Micro Electronic Interconnects", Alphametals, 1990, 4 pages.

"MILLIPACS Connector, Type A Specification", Dec. 14, 2004, 1 page.

Mottonen et al., "Novel Wide-Band Coplanar Waveguide-to-Rectangular Waveguide Transition", IEEE Transactions on Microwave Theory and Techniques, 2004, 52(8), 1836-1842.

Nadolny et al., "Optimizing Connector Selection for Gigabit Signal Speeds", <http://www.ecnmag.com/article-CA45245>, ECN, Sep. 1, 2000, 6 pages.

"NSP Series, Backplane High-Speed Data Transmission Cable Connectors", <http://www.honda-connectors.co.jp>, Honda Connectors, 2006, 6 pages, English Translation attached.

Ogando, "And now-An Injection-Molded Heat Exchanger", Sure, plastics are thermal insulators, but additive packages allow them to conduct heat instead, Global Design News, Nov. 1, 2000, 4 pages.

"Open Pin Field Array Seaf Series", www.samtec.com, SAMTEC, 2005, 1 page.

"Overview for High Density Backplane Connector (Z-Pack TinMan)", Tyco Electronics, 2008, 1 page.

"Overview for High Density Backplane Connectors (Impact) Offered by Tyco Electronics", www.tycoelectronics.com/catalog, Tyco Electronics, 2007, 1-2.

"Overview: Backplane Products", http://www.molex.com/cgi-bin/bv-molex-super_family-super_family.jsp?BV_SessionID=@, Molex, Feb. 8, 2006, 4 pages.

"PCB-Mounted Receptacle Assemblies, 2.00 mm (0.079 In) Centerlines, Right-Angle Solder-to-Board Signal Receptacle", Metral, Berg Electronics, 2 pages.

Power TwinBlade I/O Cable Connector RA-North-South, No. GS-20_072, Aug. 6, 2007, 11 pages.

"Product Datasheets, 10 Bgit/s XENPAK 850 nm Transponder (TRP1OGVP2045)", MergeOptics GmbH, 2005, 13 pages.

"Product Datasheets, Welcome to XENPAK.org", <http://www.xenpak.org>, 2001, 1 page.

Research Disclosure, Kenneth Mason Publications Ltd., England, Aug. 1990, No. 316, 1 page.

Research Disclosure, Kenneth Mason Publications Ltd., England, Oct. 1992, No. 342, 1 page.

Sherman, "Plastics that Conduct Heat", Plastics Technology Online, Jun. 2001, <http://www.plasticstechnology.com>, 4 pages.

Siemens, "SpeedPac: A New Concept for the Next Generation of Transmission Speed," Backplane Interconnection, Issue 1/96.

Soliman. et al., "Multimodel Characterization of Planar Microwave Structures", IEEE Transactions on Microwave Theory and Techniques, 2004, 52(1), 175-182.

Son et al., "Picosecond Pulse Propagation on Coplanar Striplines Fabricated on Lossy Semiconductor Substrates: Modeling and Experiments", IEEE Transactions on Microwave Theory and Techniques, 1993, 41(9), 1574-1580.

Straus, "Shielded In-Line Electrical Multiconnector", IBM Technical Disclosure Bulletin, Aug. 3, 1967, 10(3), 3 pages.

Suh et al., "Coplanar Strip line Resonators Modeling and Applications to Filters", IEEE Transactions on Microwave Theory and Techniques, 2002, 50(5), 1289-1296.

"Two-Piece, High-Speed Connectors", www.tycoelectronics.com/catalog, Tyco Electronics, 2007, 1-3.

"Tyco Unveils Z-Pack TinMan Orthogonal Connector System", <http://www.epn-online.com/page/new59327/tyco-unveils-z-pack-orthogonal-conn>, Oct. 13, 2009, 4 pages.

Tzuang et al., "Leaky Mode Perspective on Printed Antenna", Proc. Natl. Sci. Coun. ROC(A), 1999, 23(4), 544-549.

"Ventura High Performance, Highest Density Available", <http://www.amphenol-tcs.com/products/connectors/backplane/ventura/index.html>, Amphenol TCS (ATCS), Jun. 19, 2008, 1-2.

"VHDM Connector", <http://www.teradyne.com/prods/tcs/products/connectors/backplane/vhdm/index.html>, Amphenol TCS (ATCS), Jan. 31, 2006, 2 pages.

"VHDM Daughterboard Connectors Feature Press-Fit Terminations and a Non-Stubbing Separable Interface", Teradyne, Inc. Connections Sys Div, Oct. 8, 1997, 46 pages.

"VHDM High-Speed Differential (VHDM HSD)", <http://www.teradyne.com/prods/bps/vhdm/hsd.html>, Teradyne, Jan. 24, 2000, 6 pages.

"VHDM L-Series Connector", http://www.teradyne.com/prods/tcs/products/connectors/backplane/vhdm_1-series/index.html, Amphenol TCS(ATCS), 2006, 4 pages.

Weller et al., "High Performance Microshield Line Components", IEEE Transactions on Microwave Theory and Techniques, 1995, 43(3), 534-543.

Williams et al., "Accurate Transmission Line Characterization", IEEE Microwave and Guided Wave Letters, 1993, 3(8), 247-249.

Wu et al., "Full-Wave Characterization of the Mode Conversion in a Coplanar Waveguide Right-Angled Bend", IEEE Transactions on Microwave Theory and Techniques, 1995, 43(11), 2532-2538.

"XCede® Connector", <http://www.amphenol-tcs.com/products/connectors/backplane/xcede/index.html>, Amphenol TCS (ATCS), Jun. 19, 2008, 1-5.

Ya et al., "Microstrip and Slotline Two-Pole Microwave Filters with Additional Transmission Zeros", Int. Crimean Conference, Microwave & Telecommunication Technology, 2004, 405-407 (English Abstract provided).

"Z-Dok and Connector", <http://2dok.tyco.electronics.com>, Tyco Electronics, May 23, 2003, 1-15.

"Z-Pack Slim UHD", <http://www.zpackuhd.com>, Tyco Electronics, 2007, 8 pages.

"Z-Pack TinMan High Speed Orthogonal Connector Product Feature Selector", Tyco Electronics, 2009, 2 pages.

"Z-Pack TinMan Product Portfolio Expanded to Include 6-Pair Module", Tyco Electronics, Jun. 19, 2008, 1 page.

* cited by examiner

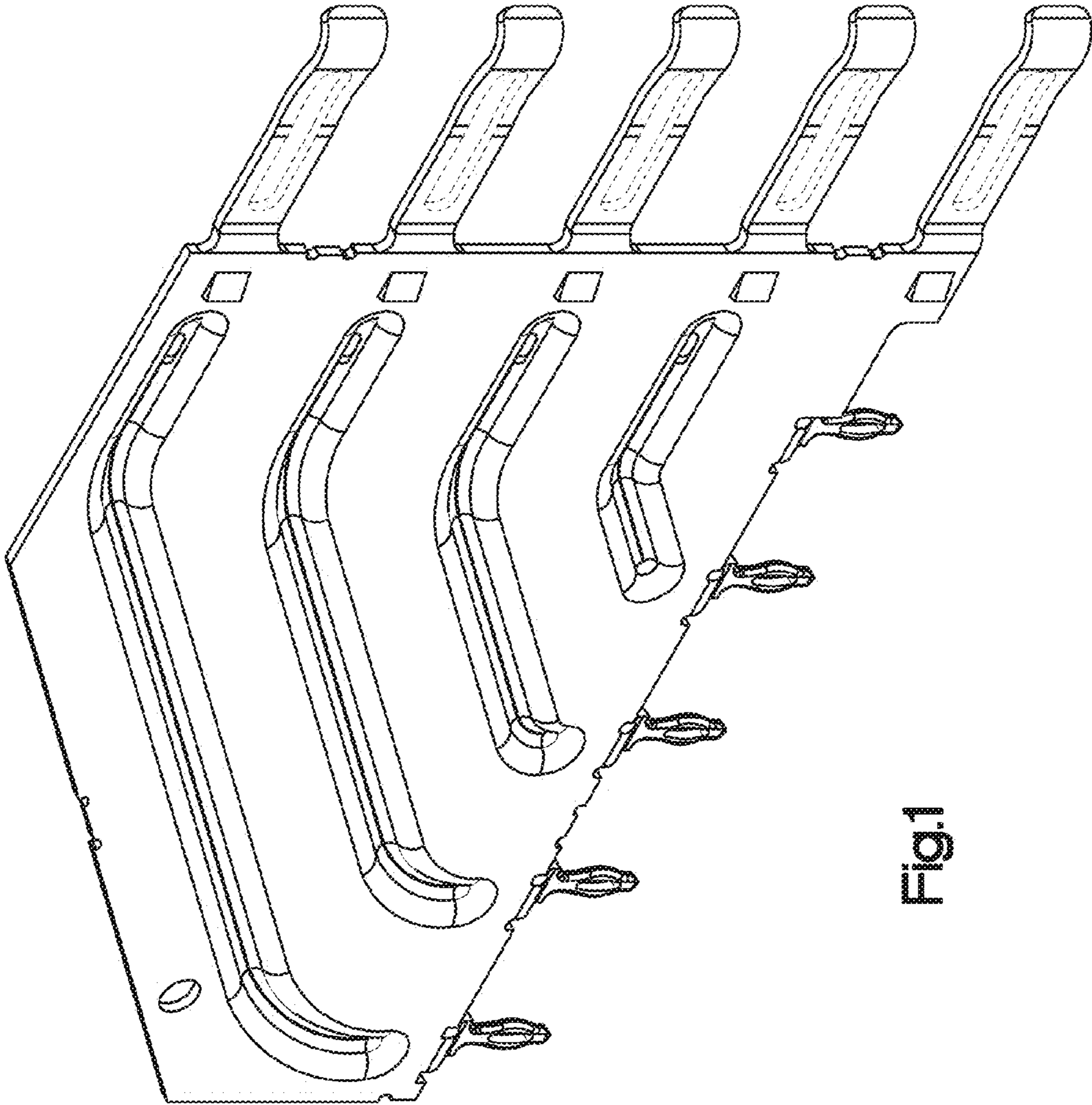

Fig.1

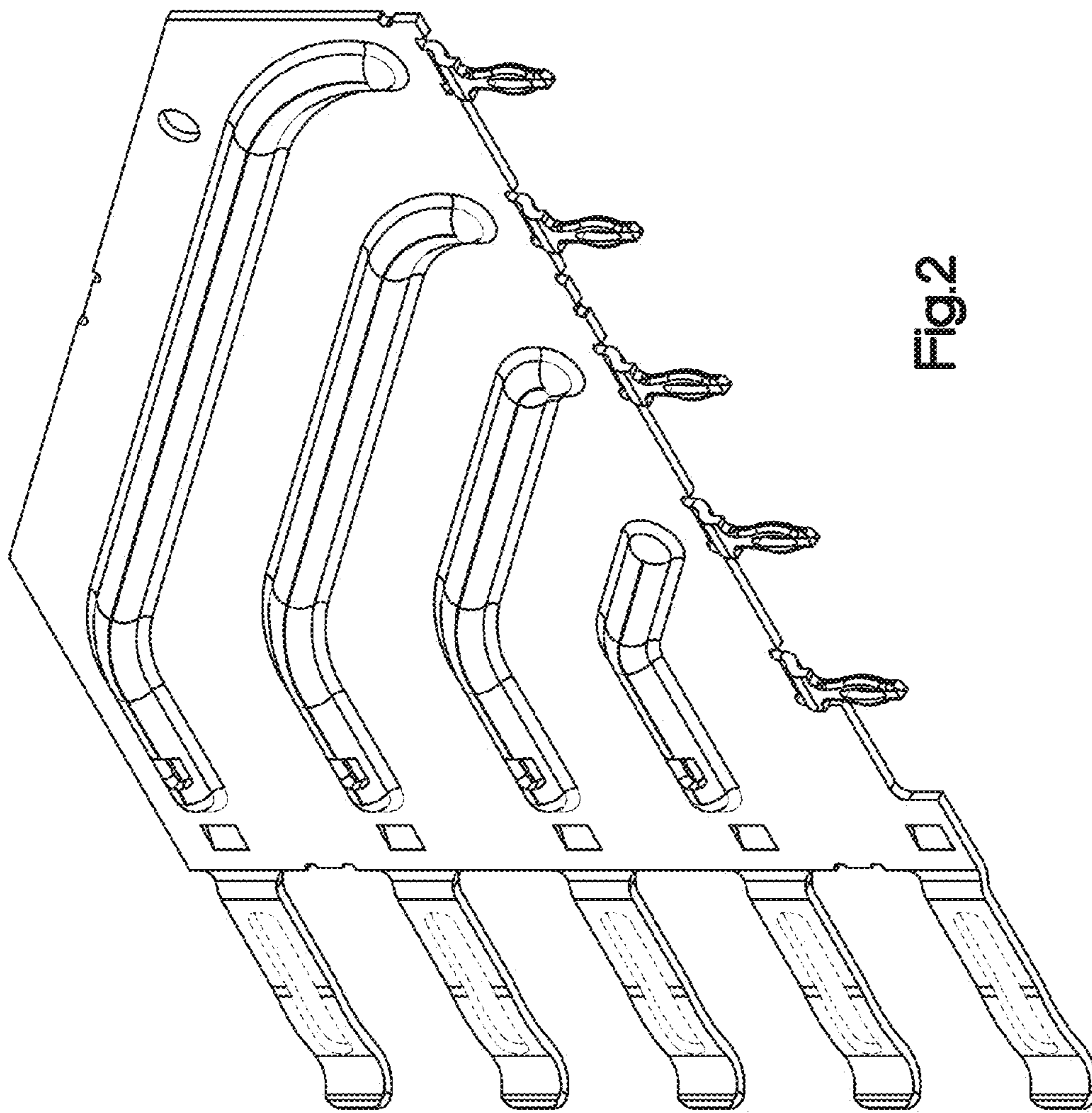

Fig. 2

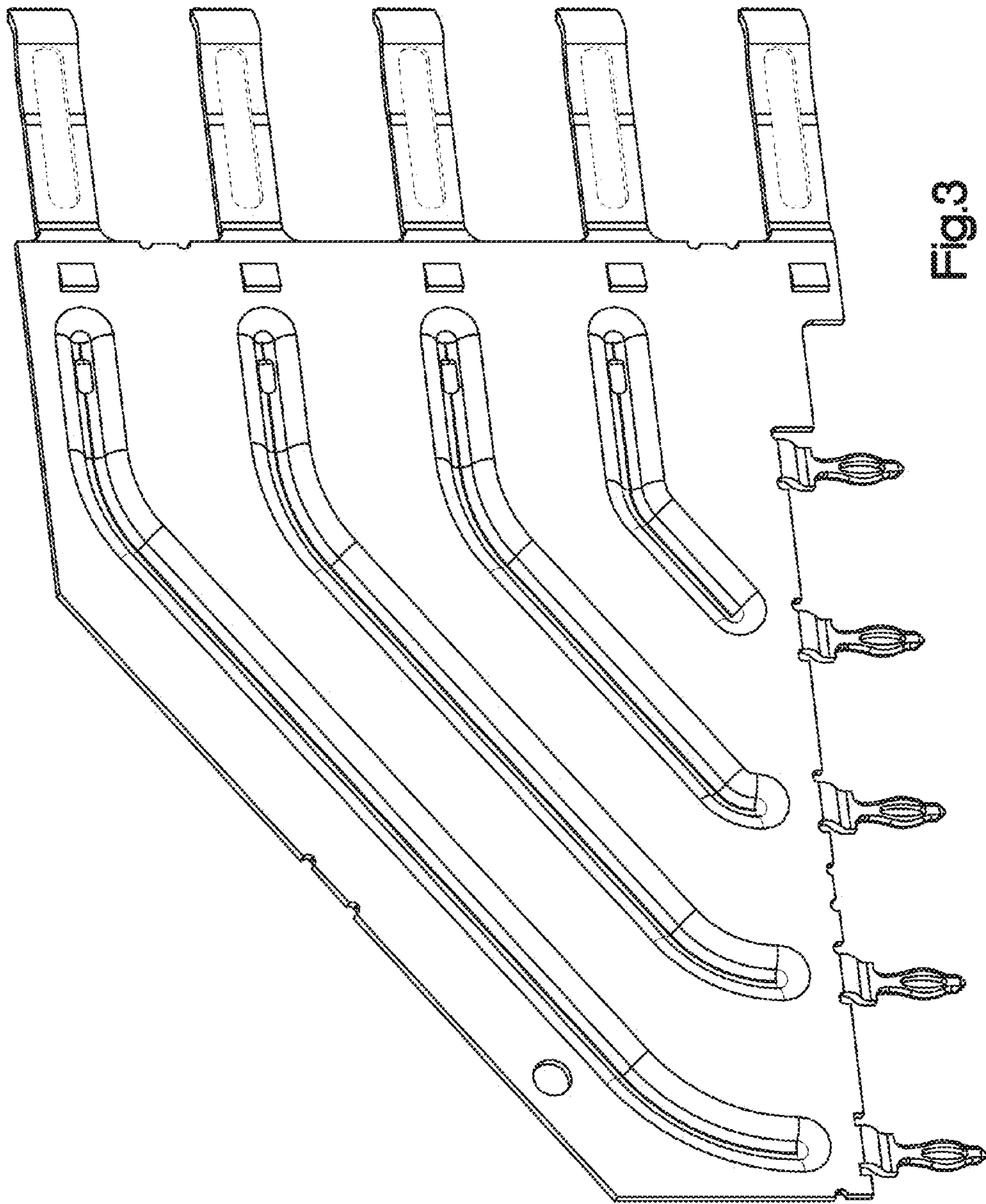

Fig. 3

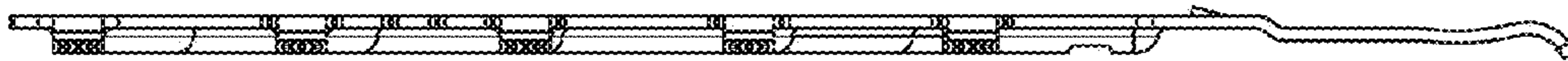

Fig.7

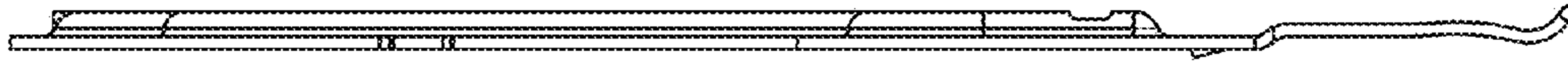

Fig.6

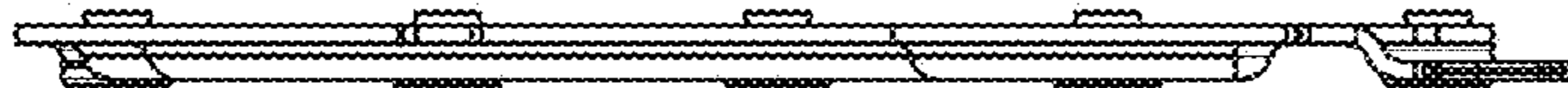

Fig.5



Fig.4

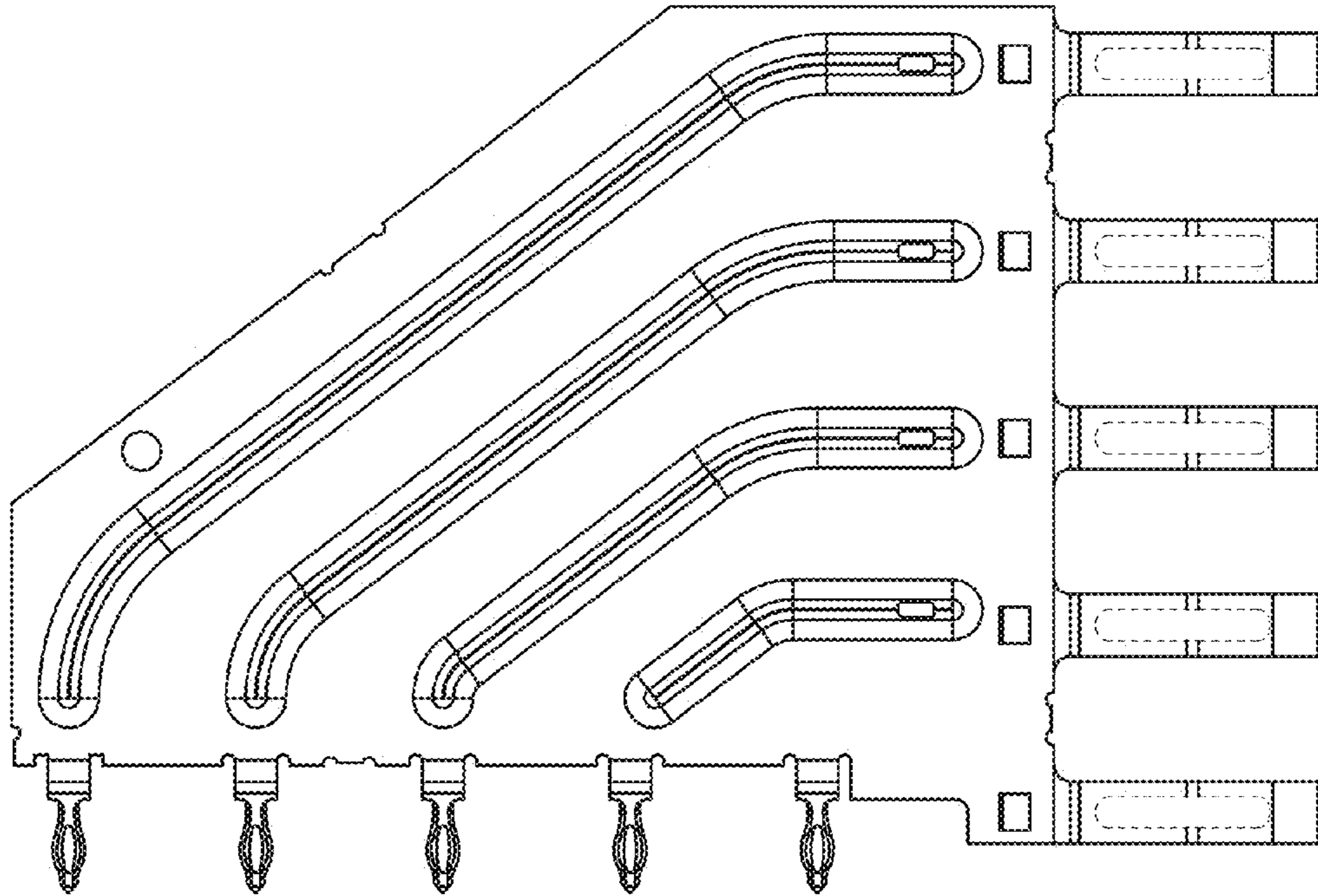

Fig.8

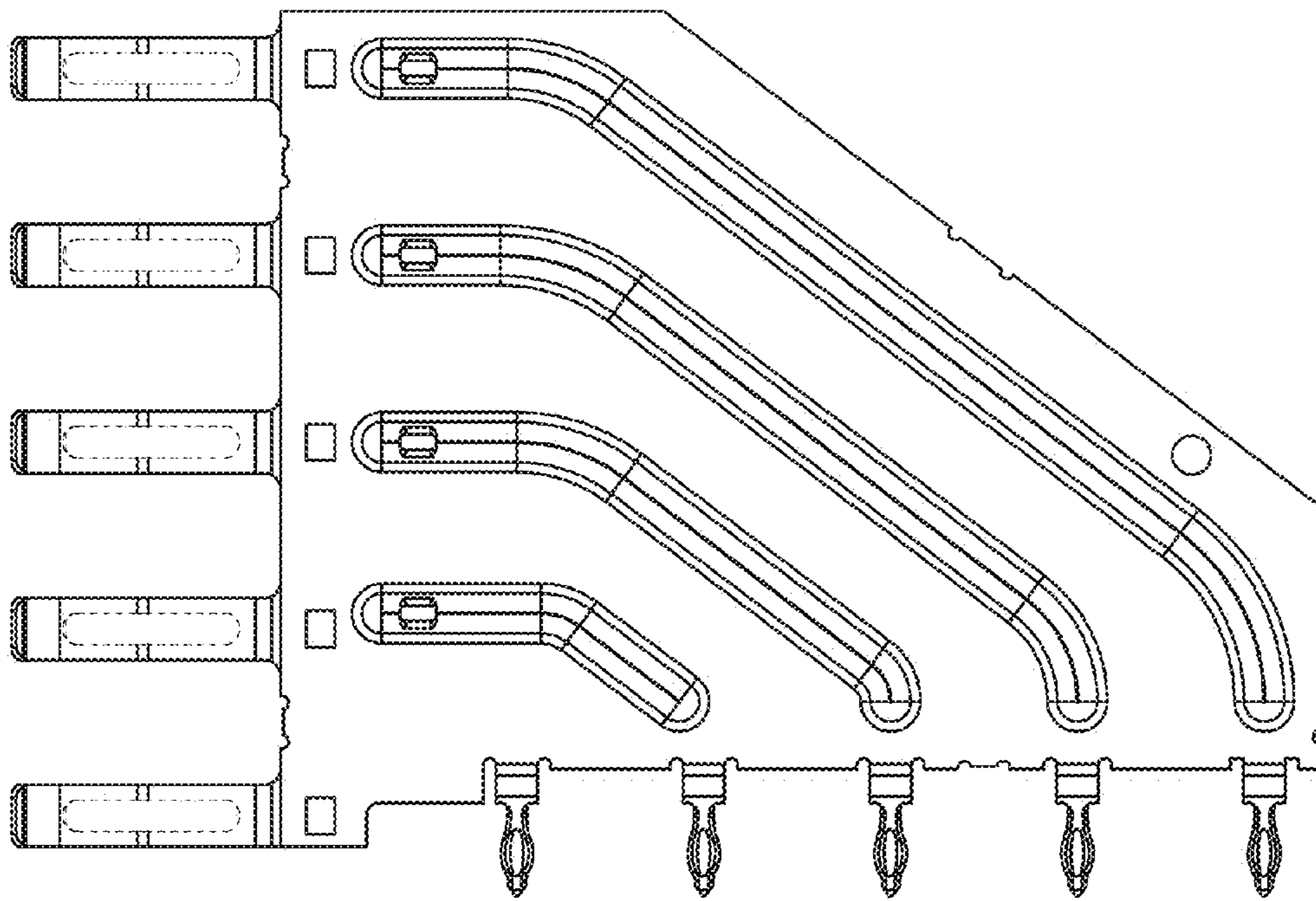

Fig.9

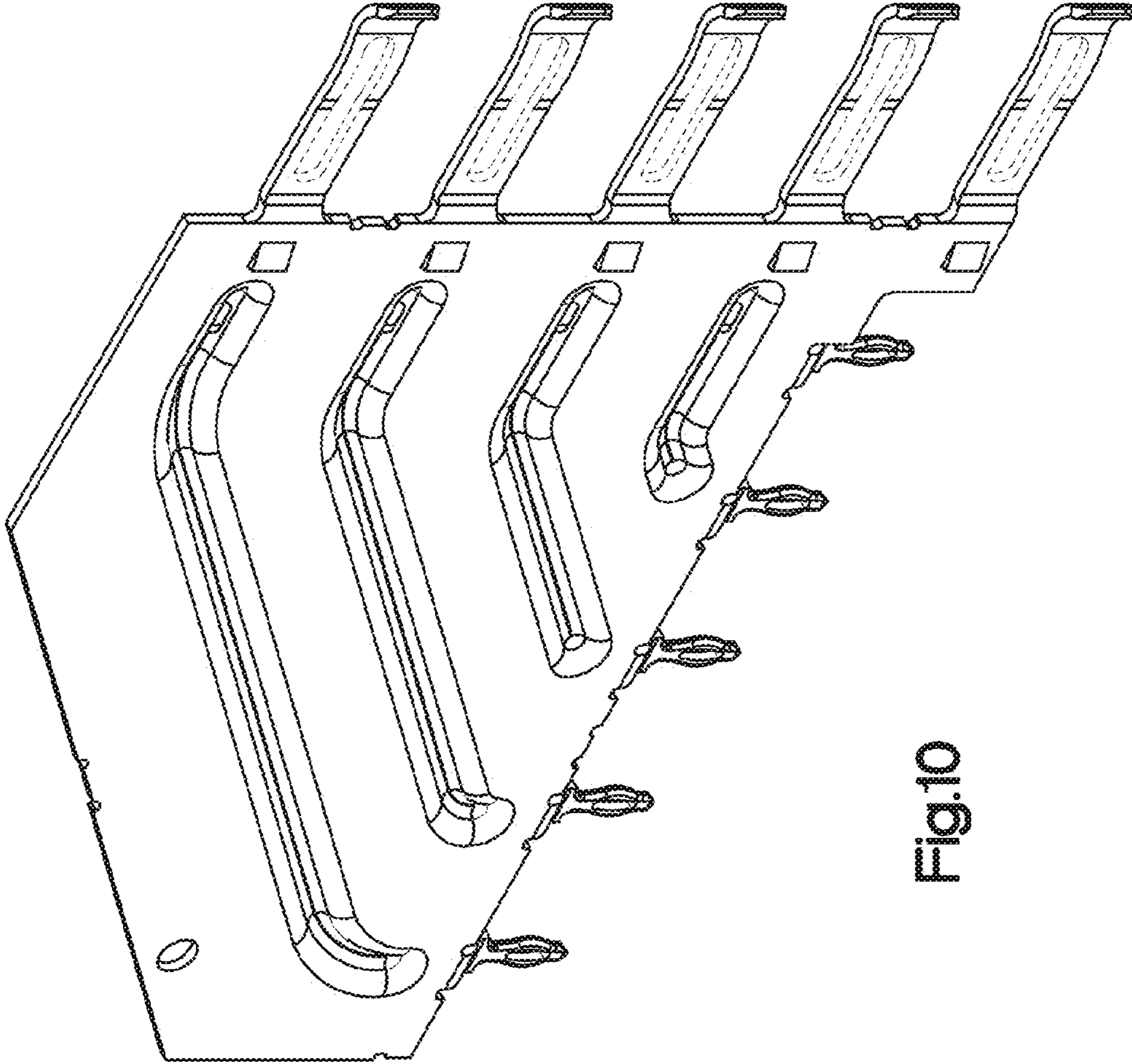

Fig.10

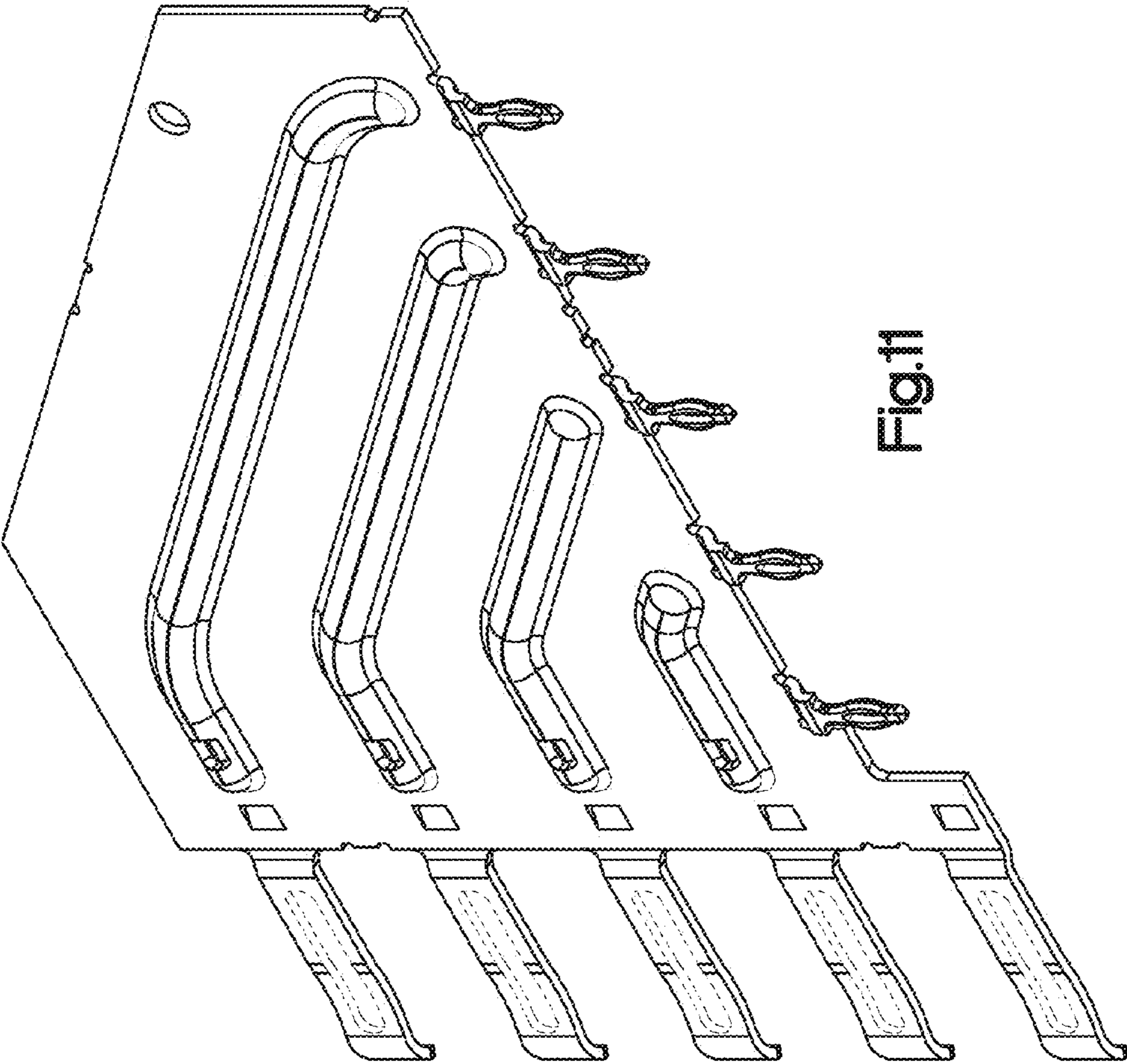

Fig.1

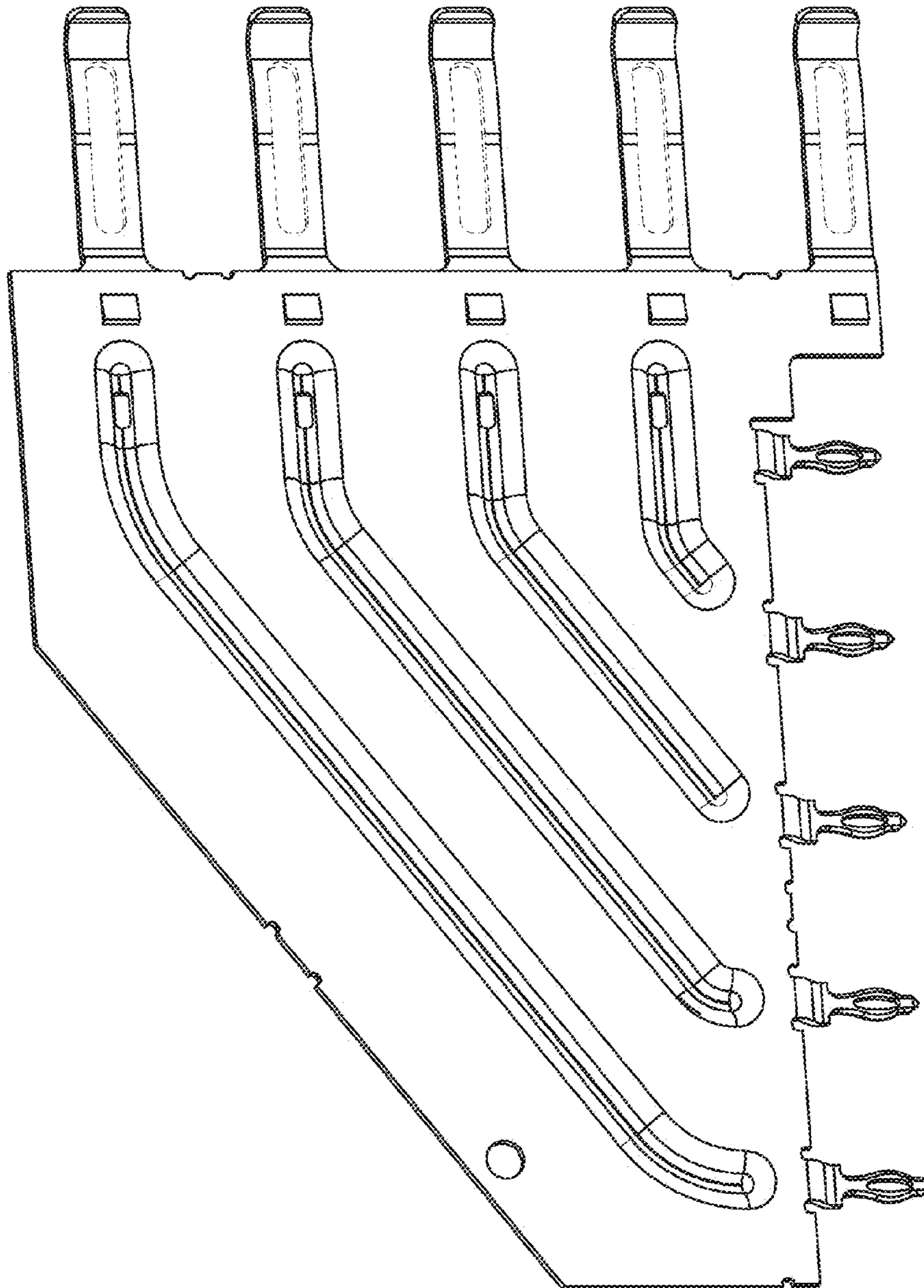

Fig.12

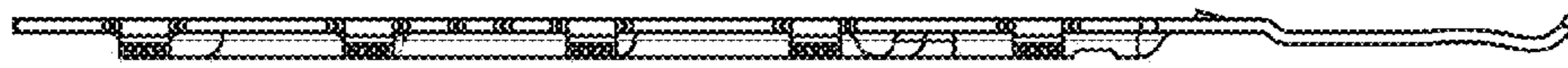

Fig.16

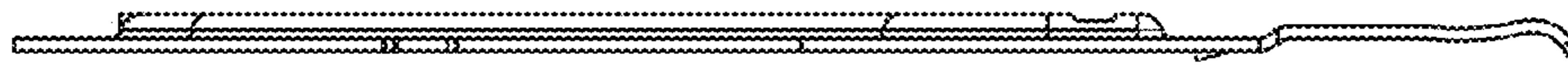

Fig.15

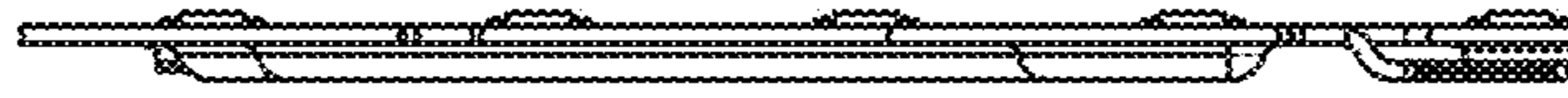

Fig.14



Fig.13

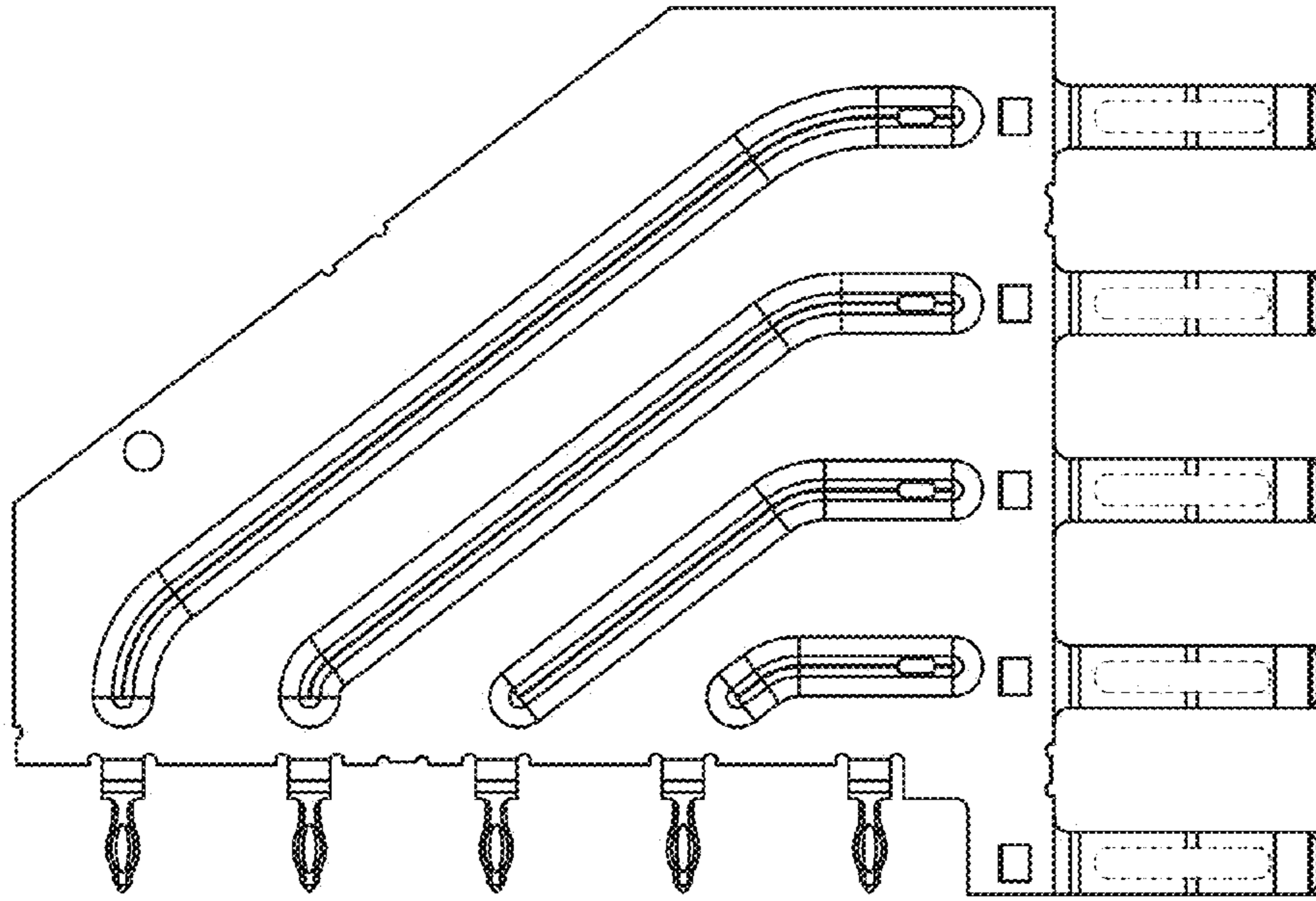

Fig.17

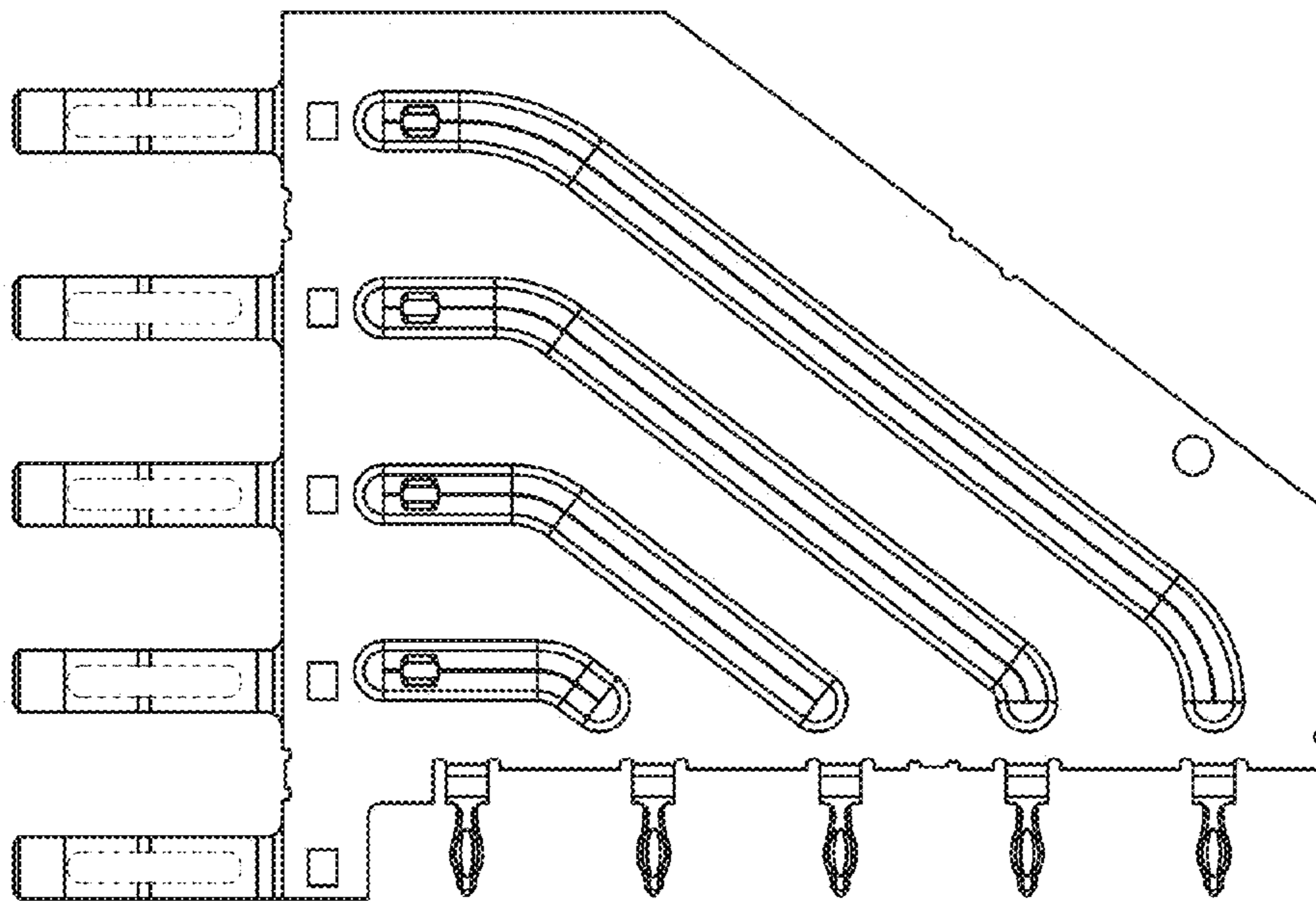

Fig.18