



US00D727808S

(12) **United States Design Patent**
Heinz

(10) **Patent No.:** **US D727,808 S**

(45) **Date of Patent:** **** Apr. 28, 2015**

(54) **MOTORCYCLE HANDLEBAR**

(71) Applicant: **Kevin David Heinz**, Briarcliff, TX (US)

(72) Inventor: **Kevin David Heinz**, Briarcliff, TX (US)

(**) Term: **14 Years**

(21) Appl. No.: **29/495,987**

(22) Filed: **Jul. 8, 2014**

(51) **LOC (10) Cl.** **12-11**

(52) **U.S. Cl.**
USPC **D12/178**

(58) **Field of Classification Search**

CPC B62K 19/16; B62K 21/12; B62K 21/18;
B62K 21/125; B62K 23/06

USPC D12/111, 114, 178; D8/303; 74/502.2,
74/551.1-551.8; 280/274, 281.1, 288.4

See application file for complete search history.

(56) **References Cited**

U.S. PATENT DOCUMENTS

D223,072 S *	3/1972	Pawsat	D12/178
D224,696 S *	8/1972	Pawsat	D12/178
D317,284 S *	6/1991	McMurtrey	D12/178
5,257,552 A *	11/1993	Boyer et al.	74/551.1
D342,475 S *	12/1993	Haro	D12/178
D393,438 S *	4/1998	Cartwright	D12/178
D542,197 S *	5/2007	Carlini	D12/178
7,350,437 B2 *	4/2008	Mangano et al.	74/551.1
D572,181 S *	7/2008	Lujan	D12/178
D604,212 S *	11/2009	Carlini	D12/178
D612,307 S *	3/2010	Lujan	D12/178
D621,755 S *	8/2010	Carlini	D12/178
D629,343 S *	12/2010	Carlini	D12/178
D639,211 S *	6/2011	Lujan	D12/110

(Continued)

OTHER PUBLICATIONS

“Recently Added Vindikta 1” Sierra Motorcycle Handlebars.”
Vindikta., Oct. 7, 2011 [online], [retrieved on Oct. 27, 2014].

Retrieved from the Internet <URL: <http://www.vindikta.com/2011/10/07/recently-added-vindikta-1-sierra-motorcycle-handlebars/>>.*

(Continued)

Primary Examiner — Philip S Hyder

Assistant Examiner — Darlington Ly

(74) *Attorney, Agent, or Firm* — Meyertons, Hood, Kivlin,
Kowert & Goetzel, P.C.; Eric B. Meyertons

(57) **CLAIM**

The ornamental design for a motorcycle handlebar, as shown and described.

DESCRIPTION

FIG. 1 is a front and left-side perspective view of a motorcycle handlebar;

FIG. 2 is a rear and left-side perspective view thereof;

FIG. 3 is a left-side elevation view thereof;

FIG. 4 is a rear elevation view thereof;

FIG. 5 is a right-side elevation view thereof;

FIG. 6 is a front elevation view thereof;

FIG. 7 is a top plan view thereof;

FIG. 8 is a bottom plan view thereof;

FIG. 9 is a cross-sectional view thereof, wherein the cut line is taken at 9-9 in FIG. 3;

FIG. 10 is a cross-sectional view thereof, wherein the cut line is taken at 10-10 in FIG. 4;

FIG. 11 is a cross-sectional view thereof, wherein the cut line is taken at 11-11 in FIG. 4;

FIG. 12 is a cross-sectional view thereof, wherein the cut line is taken at 12-12 in FIG. 5;

FIG. 13 is a cross-sectional view thereof, wherein the cut line is taken at 13-13 in FIG. 7; and,

FIG. 14 is a cross-sectional view thereof, wherein the cut line is taken at 14-14 in FIG. 7.

In FIGS. 1-6 and 9-14, the motorcycle handlebar is shown with a symbolic break in its length. The broken lines and the appearance of any portion of the article between the break lines form no part of the claimed design.

1 Claim, 6 Drawing Sheets

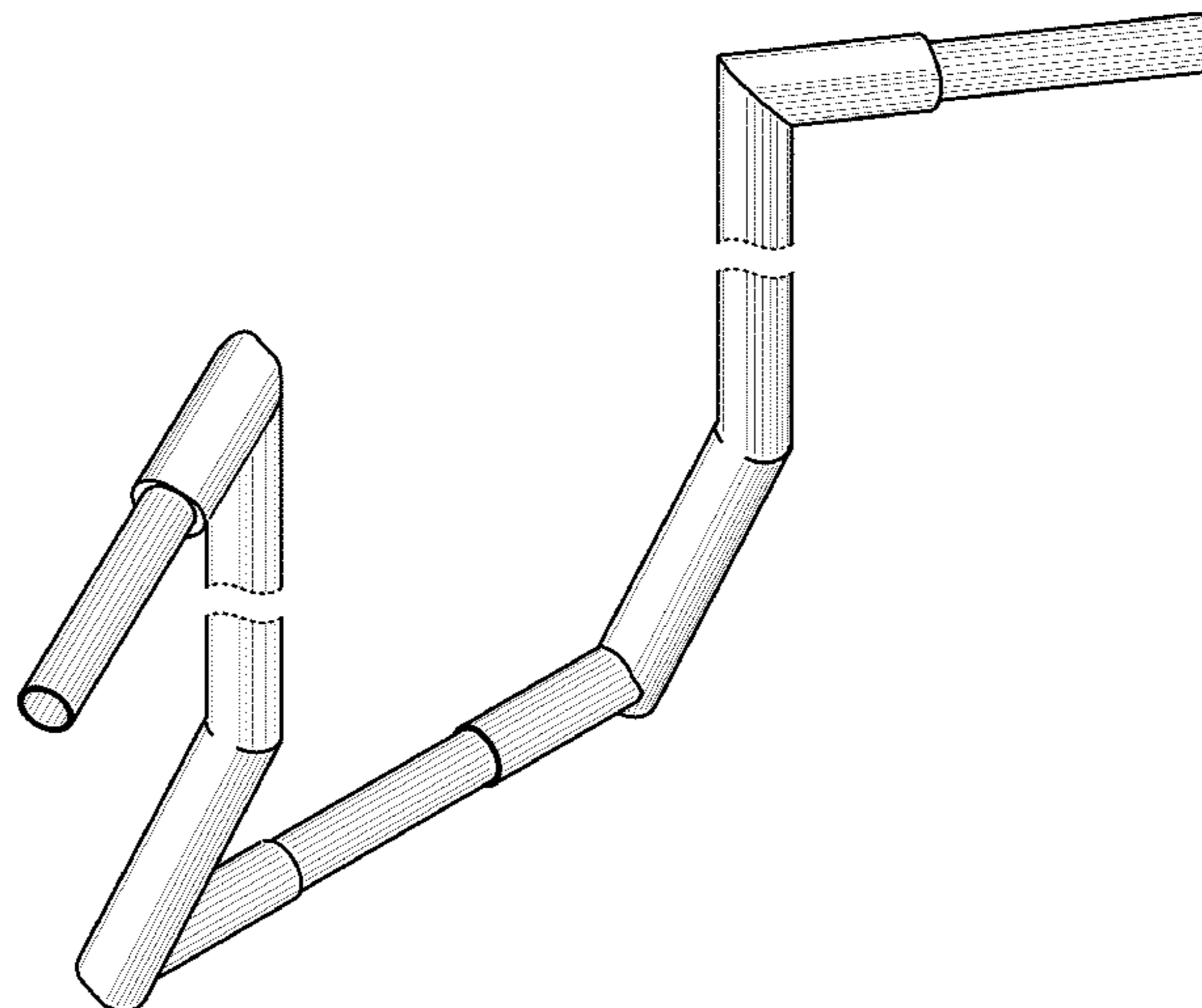

(56)

References Cited

U.S. PATENT DOCUMENTS

D664,079 S *	7/2012	Lujan	D12/178
D687,753 S *	8/2013	Carlini	D12/178
D689,418 S *	9/2013	Menefee	D12/178
2012/0210821 A1 *	8/2012	Carlini	74/551.8

OTHER PUBLICATIONS

Bdbecker. "View Single Post." Victory Forums., Apr. 1, 2010 [online], [retrieved on Oct. 27, 2014]. Retrieved from the Internet <URL: <http://www.victoryforums.com/showpost.php?s=1cfd82d9845b642be63a764a145daeb3&p=6608&postcount=2>>.*

"Biltwell Zed Handlebars—1"—Black." Lowbrow Customs., Mar. 12, 2013 [online], [retrieved on Oct. 27, 2014]. Retrieved from the Internet <URL: <http://www.lowbrowcustoms.com/p2068/buy/m-c-parts/bars-risers-amp-controls/handlebars/1-quot-/biltwell-zed-handlebars-1-quot-black/>>.*

Street Glide Bagger Bend Full Crush Tube Handlebar as found on web site address "<http://www.motorcyclebilletbling.com/STREET-GLIDE-BAGGER-BEND-FULL-CRUSH-TUBE-HANDLEBAR-RMHD-SGFCBBHB.htm>" date unknown.

Road Glide Full Crush Tube Handlebars as found on web site address "<http://www.motorcyclebilletbling.com/ROAD-GLIDE-FULL-CRUSH-TUBE-HANDLEBARS-RMHD-RGFCHB.htm>" date unknown.

* cited by examiner

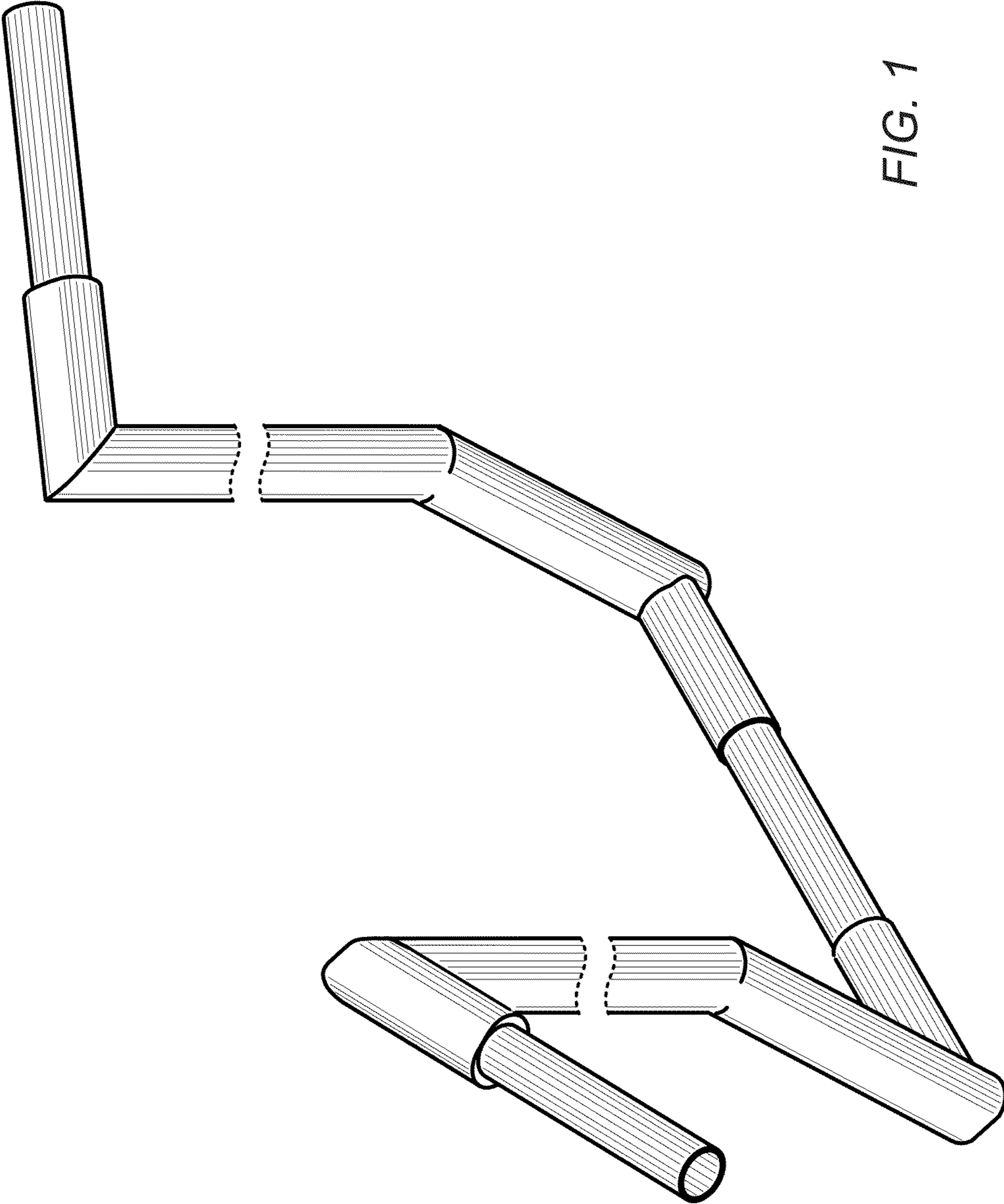

FIG. 1

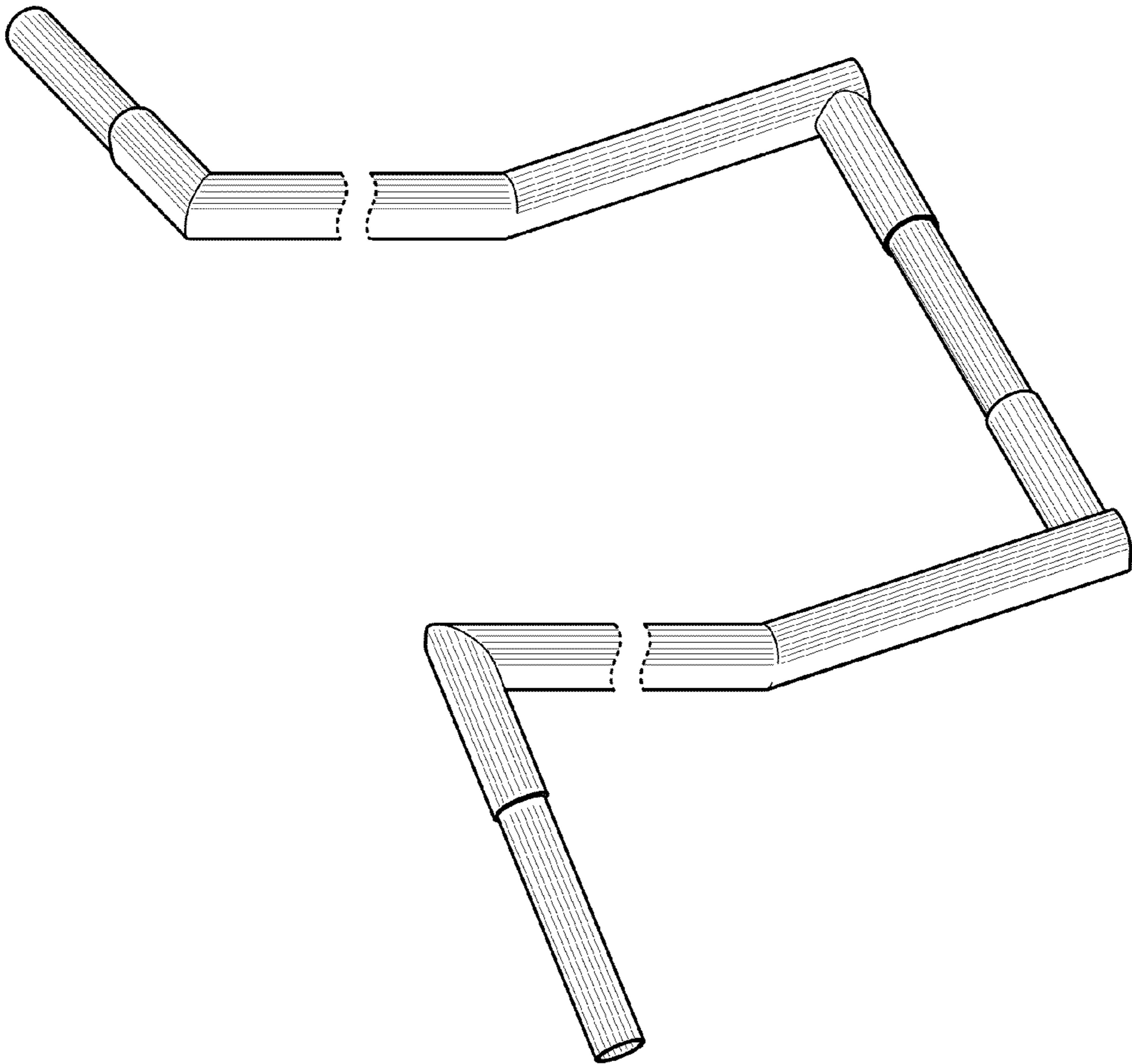
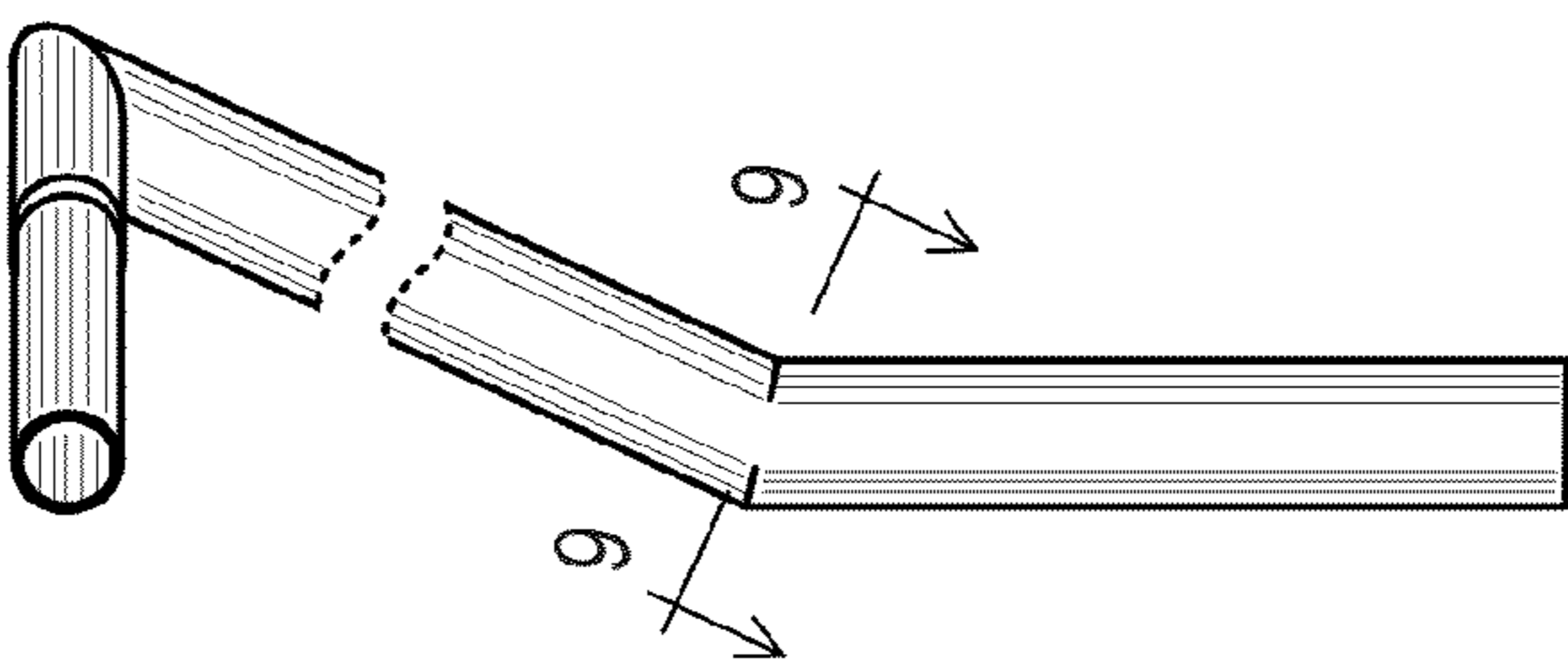
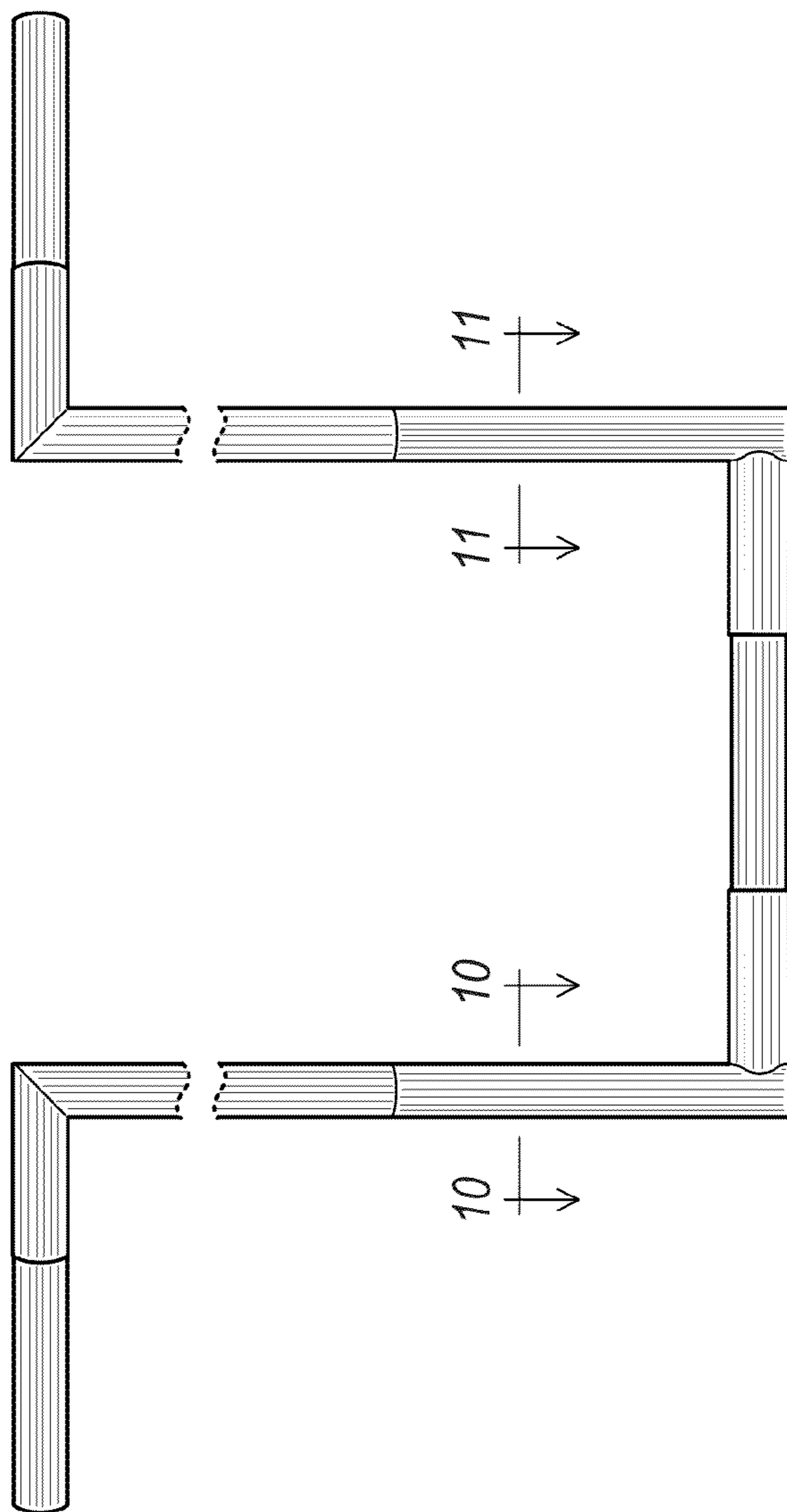

FIG. 2



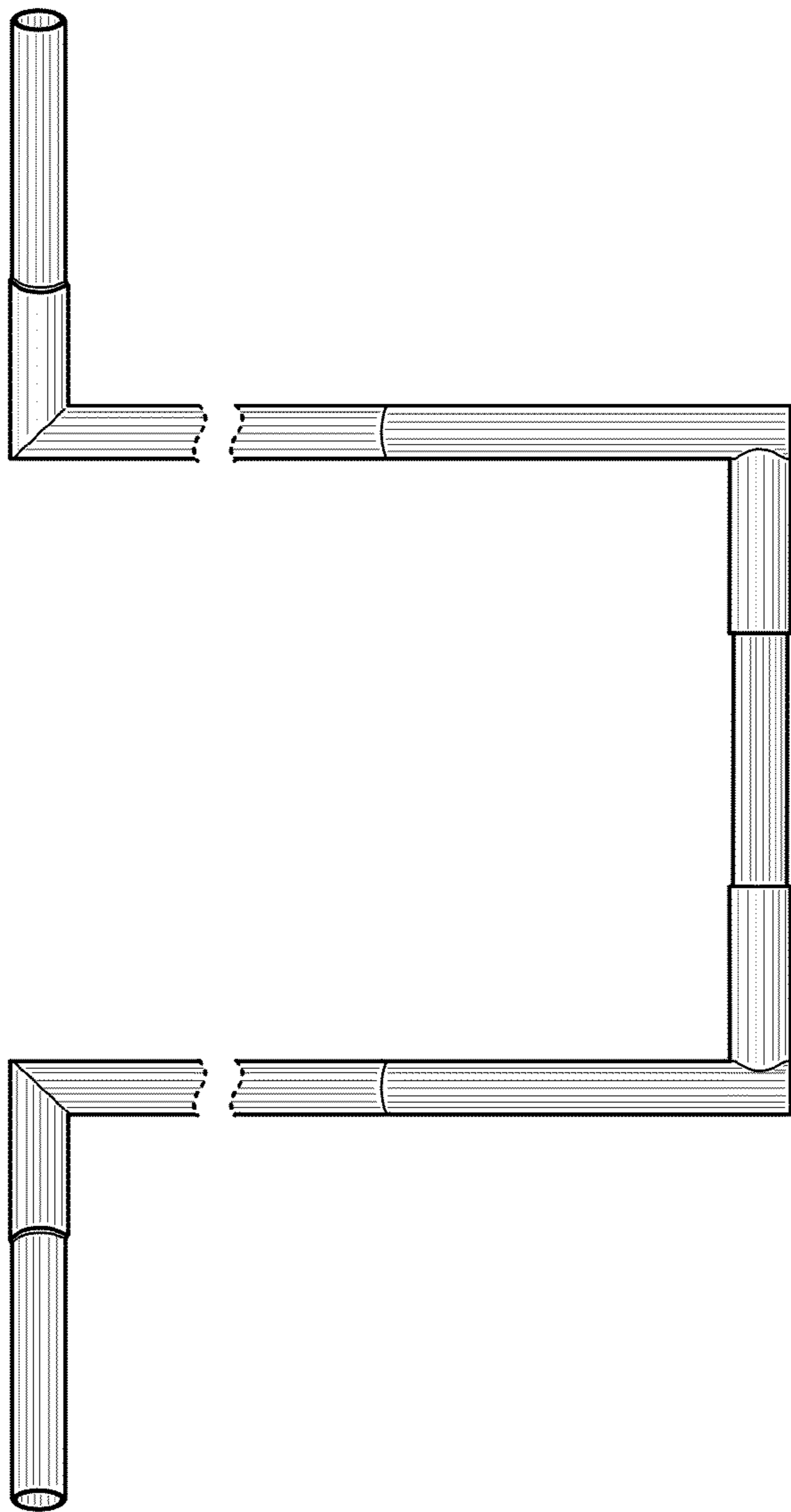

FIG. 6

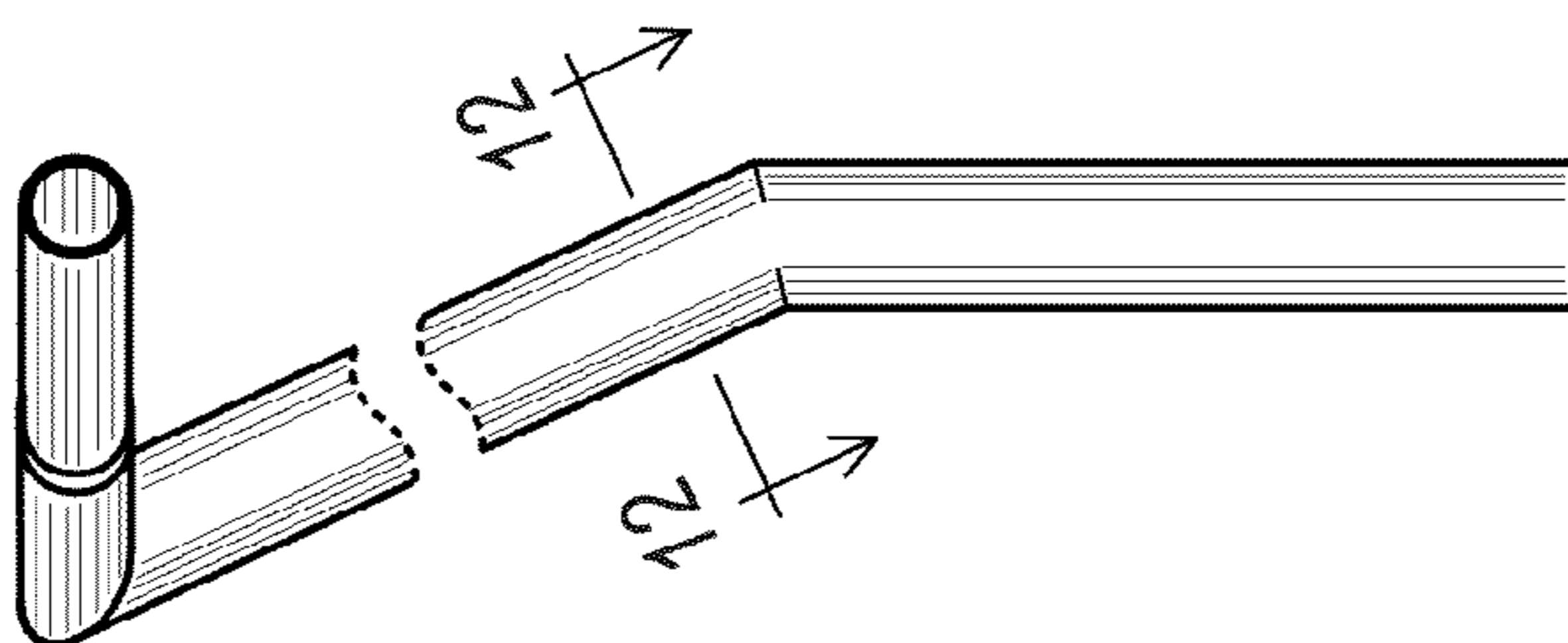

FIG. 5

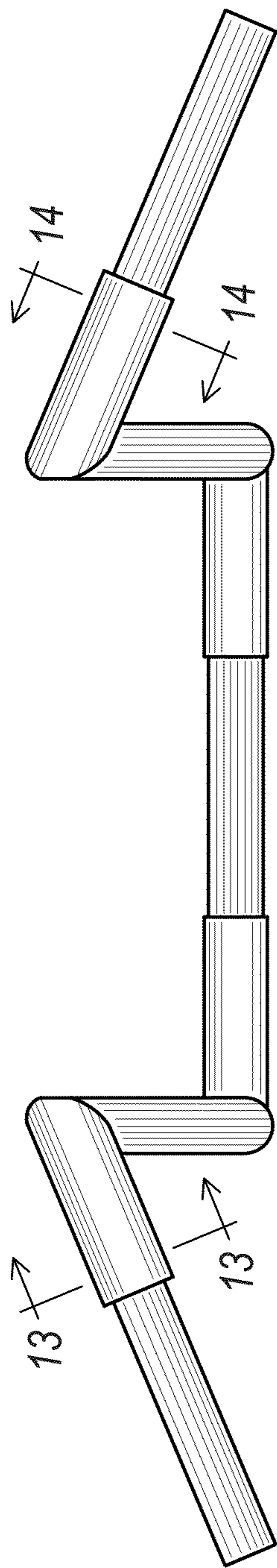

FIG. 7

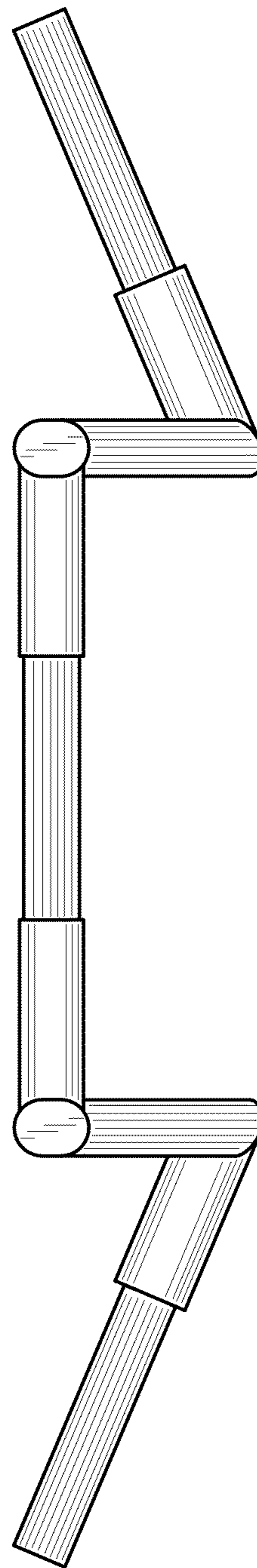

FIG. 8

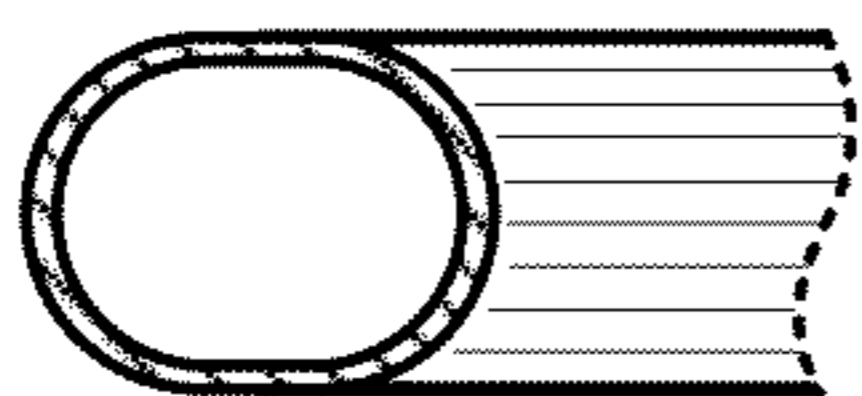

FIG. 9

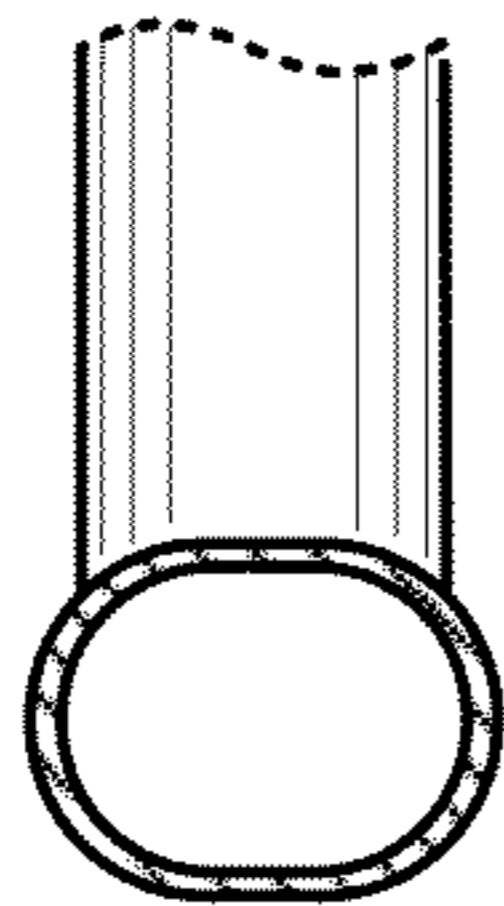

FIG. 10

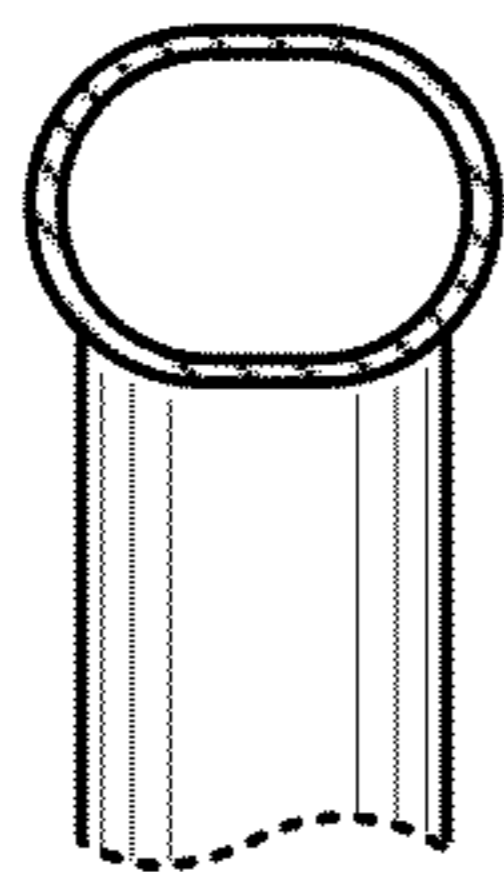

FIG. 11

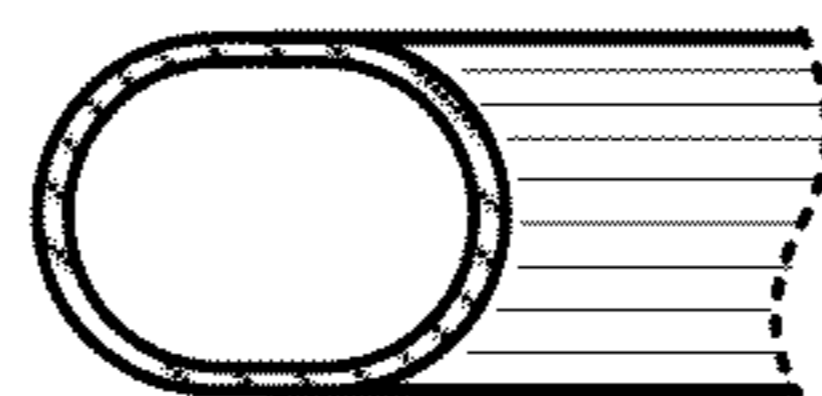

FIG. 12

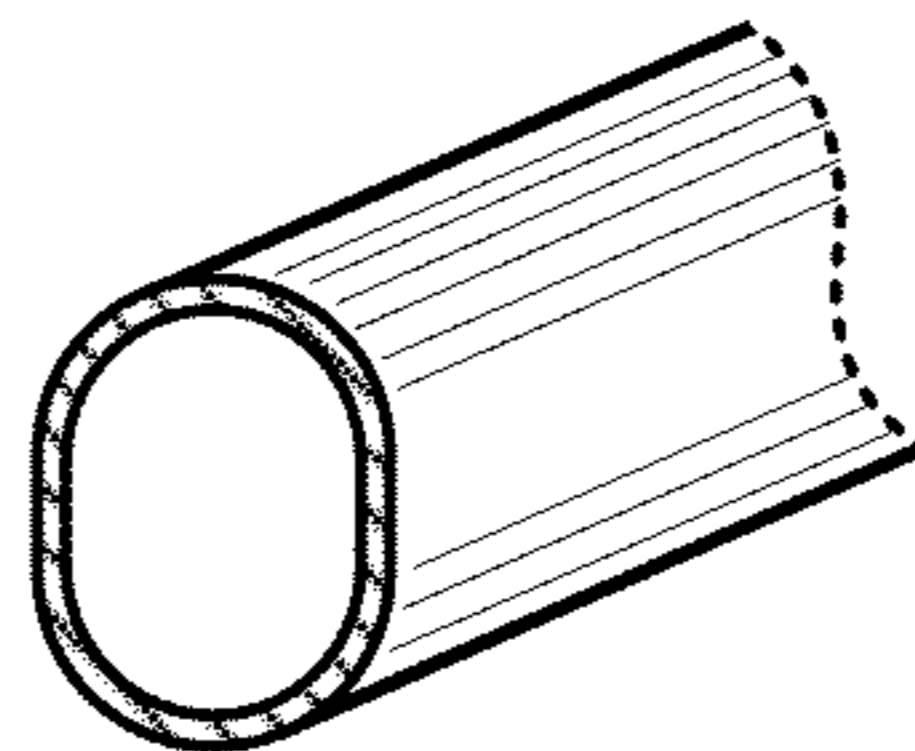

FIG. 13

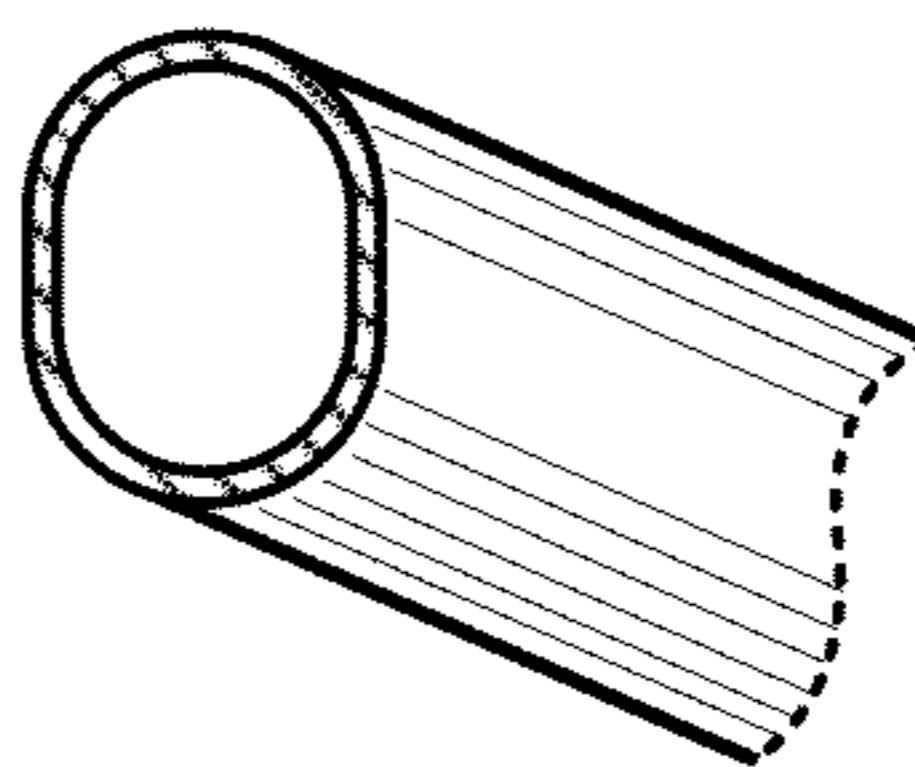

FIG. 14