



US00D727698S

(12) **United States Design Patent**
Su et al.

(10) **Patent No.:** **US D727,698 S**
(45) **Date of Patent:** **** Apr. 28, 2015**

(54) **DRIVING HEAD ASSEMBLY FOR A PNEUMATIC RATCHET WRENCH**

(56) **References Cited**

U.S. PATENT DOCUMENTS

(71) Applicants: **San-Yih Su**, Taichung (TW); **Da-Jie Lin**, Taichung (TW)
(72) Inventors: **San-Yih Su**, Taichung (TW); **Da-Jie Lin**, Taichung (TW)
(73) Assignee: **Basso Industry Corp.**, Taichung (TW)
(**) Term: **14 Years**

D326,804 S *	6/1992	Schultz	D8/61
D440,848 S *	4/2001	Izumisawa	D8/61
D517,620 S *	3/2006	Mazloompour	D21/698
D525,501 S *	7/2006	Chen	D8/61
D527,593 S *	9/2006	Price et al.	D8/61
D530,171 S *	10/2006	Baker	D8/61
7,121,167 B1 *	10/2006	Miner	81/57.39
D535,535 S *	1/2007	Baker	D8/25
D576,460 S *	9/2008	Price et al.	D8/61
D580,247 S *	11/2008	Taniguchi et al.	D8/61
D636,245 S *	4/2011	Adkins	D8/70

(21) Appl. No.: **29/450,866**

* cited by examiner

(22) Filed: **Mar. 25, 2013**

Primary Examiner — Randall Gholson

(30) **Foreign Application Priority Data**

(74) *Attorney, Agent, or Firm* — Andrew F. Young, Esq.; Lackenbach Siegel, LLP

Oct. 1, 2012 (TW) 101305773

(51) **LOC (10) Cl.** **08-05**

(52) **U.S. Cl.**
USPC **D8/25; D8/61**

(58) **Field of Classification Search**
CPC B25B 13/00; B25B 13/46
USPC D8/17, 21–29, 59–62, 64, 67, 68, 70, D8/82; 81/54, 57, 57.11, 57.13, 57.14, 81/57.42, 57.29, 57.39, 58, 60–63.2, 81/177.1, 177.4, 177.6, 177.8, 177.9, 81/177.85, 469, 474; 173/13, 104, 114, 173/167–173, 178, 182, 201, 211, 213, 173/217; 227/8, 113, 114, 120, 130, 136, 227/142; 310/50; 408/20, 124, 125, 234, 408/241 R; 451/358

(57) **CLAIM**

The ornamental design for a driving head assembly for a pneumatic ratchet wrench, as shown and described.

DESCRIPTION

FIG. 1 is a front perspective view of the invention.
FIG. 2 is a front elevation view of FIG. 1.
FIG. 3 is a rear elevation view of FIG. 1.
FIG. 4 is a left side elevation view of FIG. 1.
FIG. 5 is a right side rear elevation view of FIG. 1.
FIG. 6 is a top plan view of FIG. 1; and,
FIG. 7 is a bottom plan view of FIG. 1.

The broken lines shown in the drawings represent portions of the driving head assembly for a pneumatic ratchet wrench that form no part of the claimed design. No claim is made to any surface texture or finish, the drawings are lined lightly only to indicate contour.

See application file for complete search history.

1 Claim, 4 Drawing Sheets

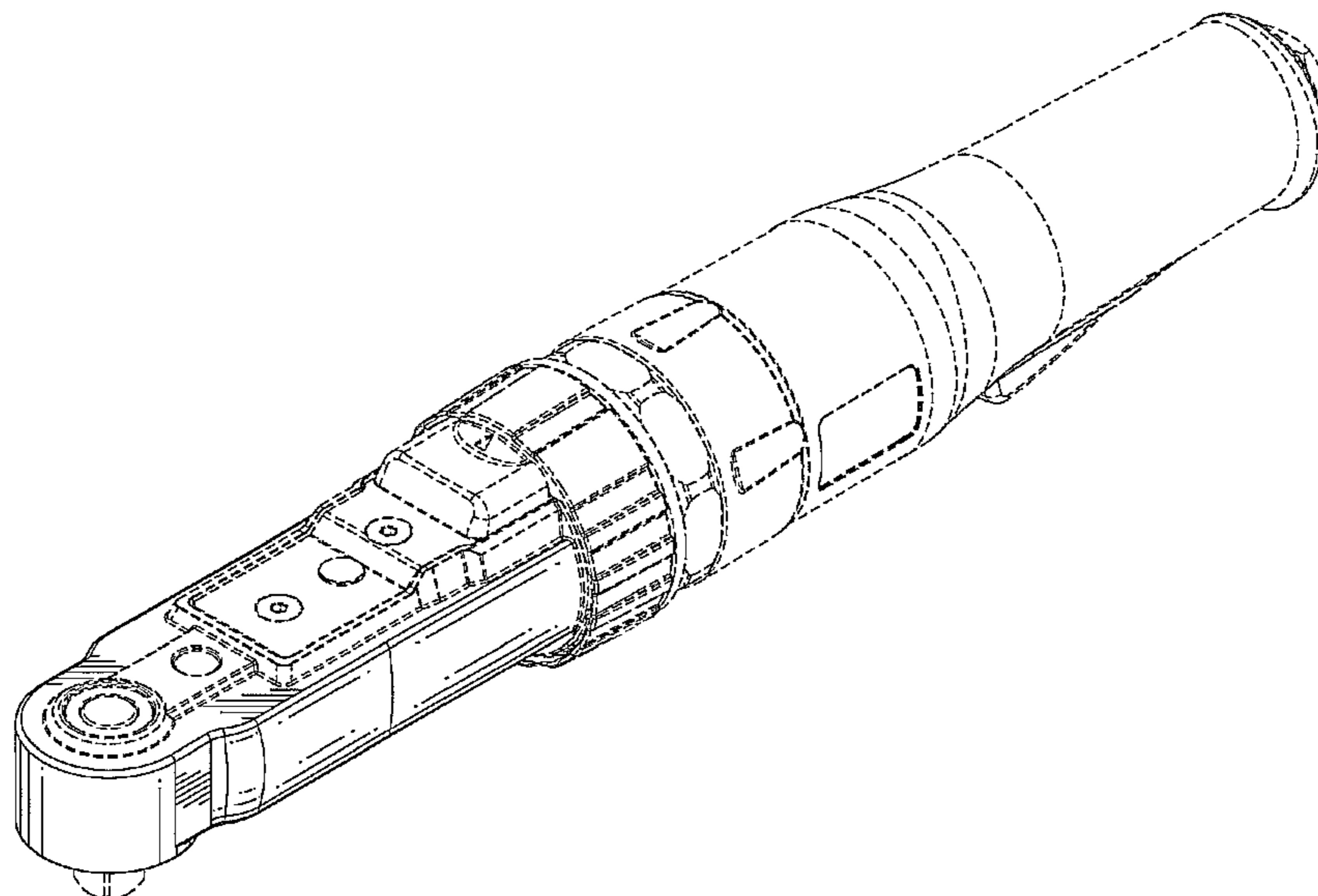

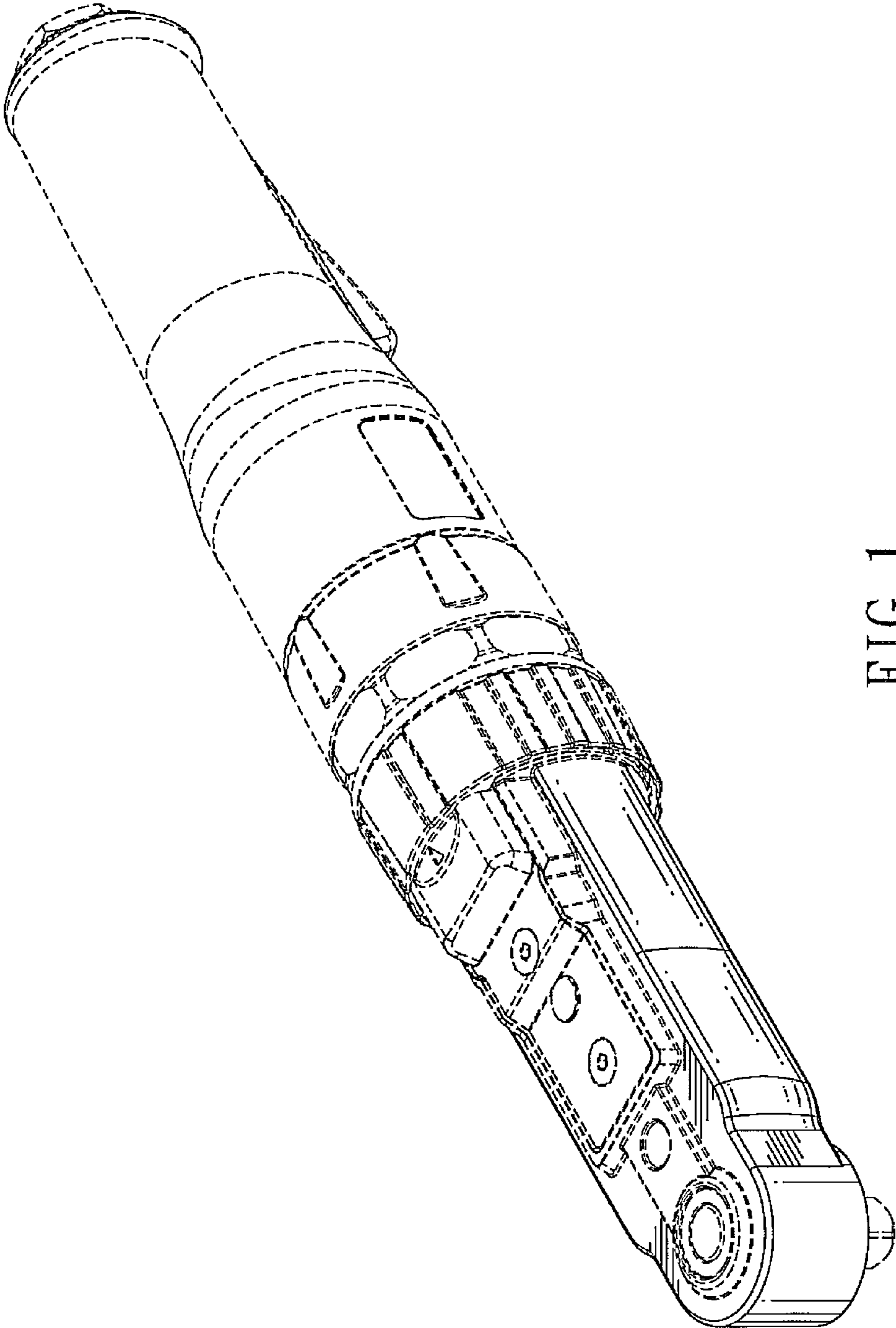

FIG. 1

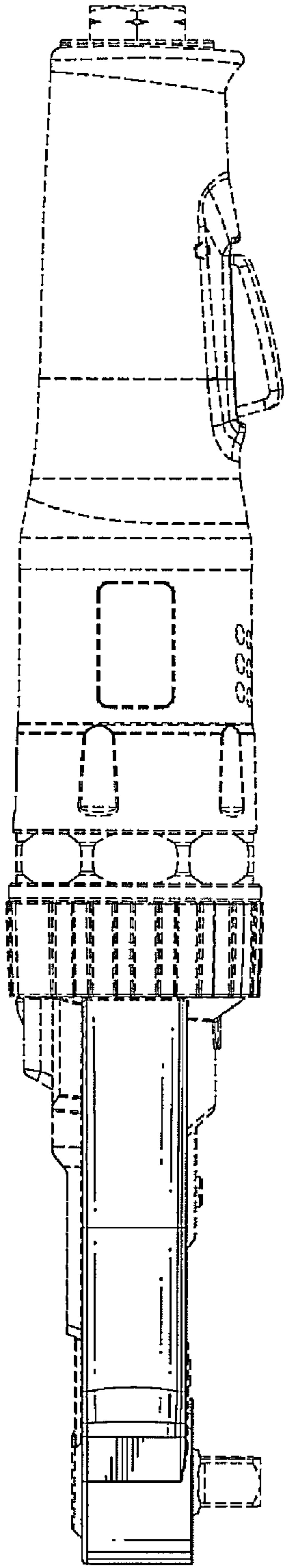

FIG. 2

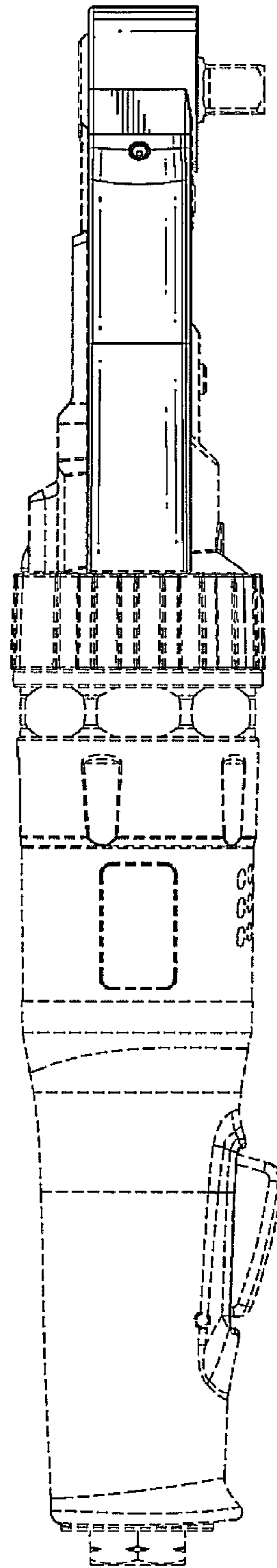

FIG. 3

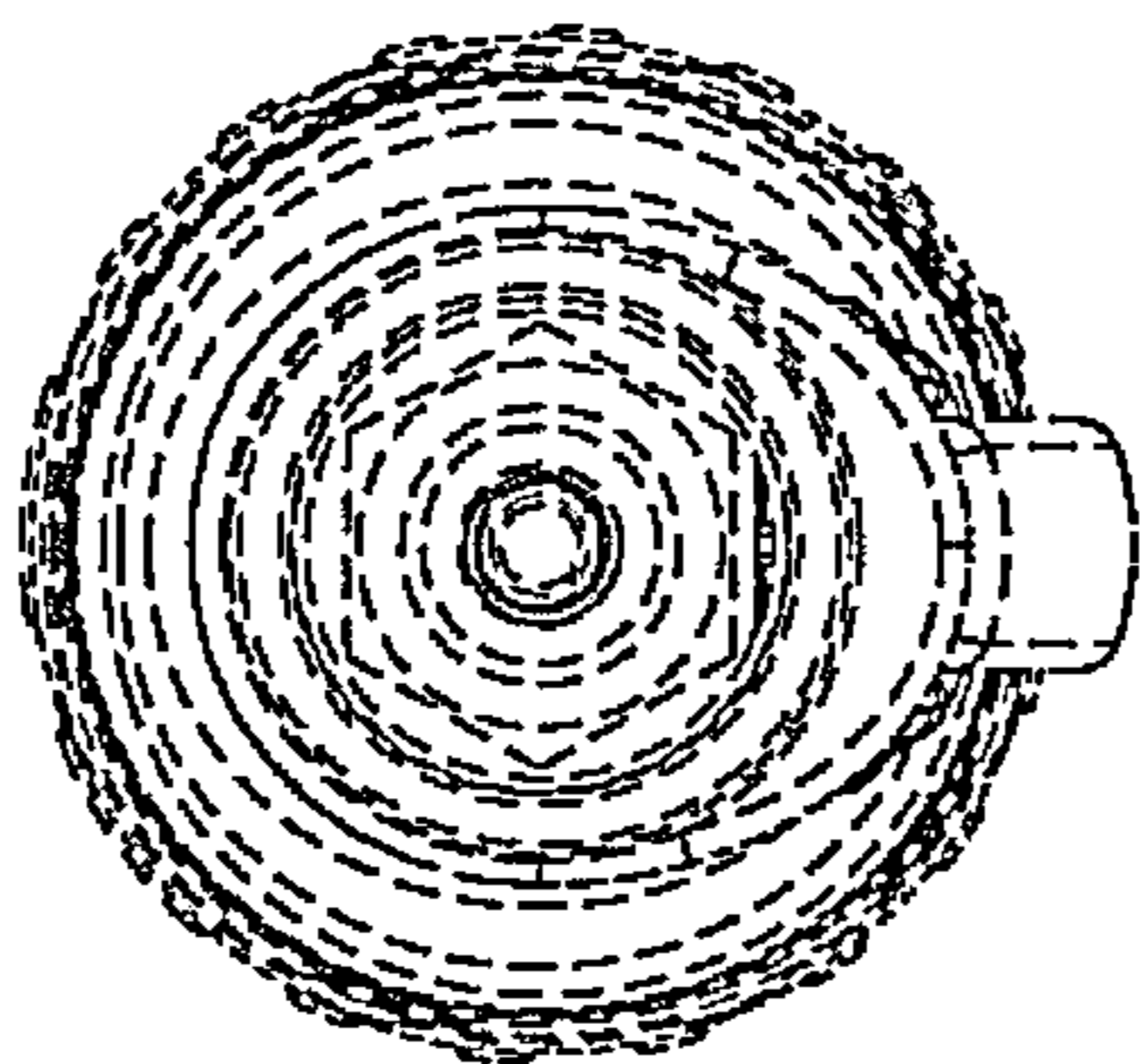

FIG. 5

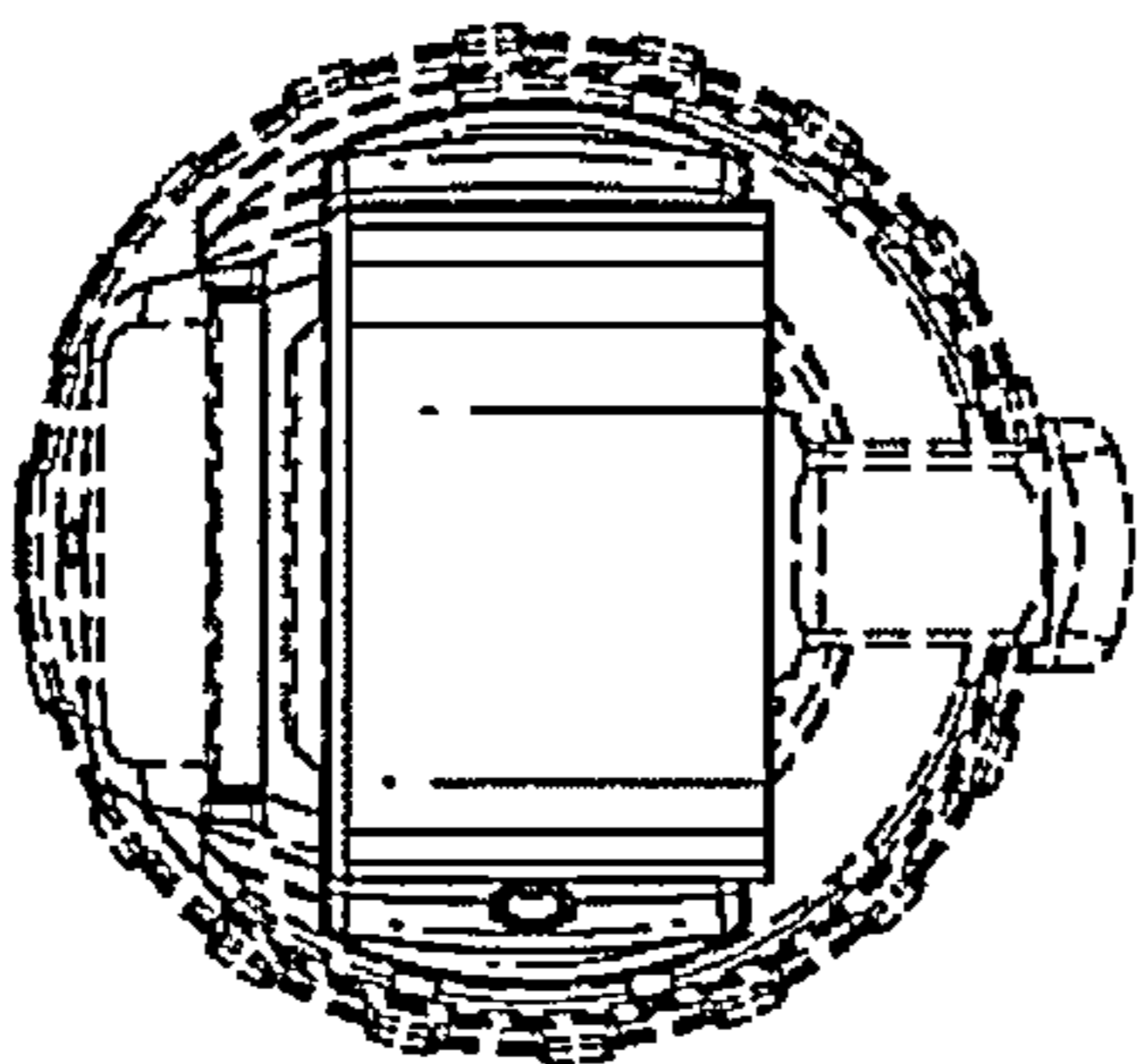

FIG. 4

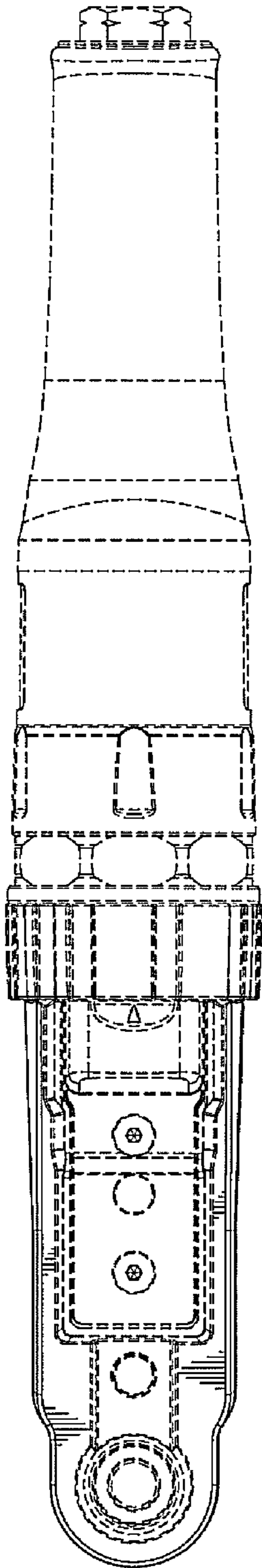

FIG. 6

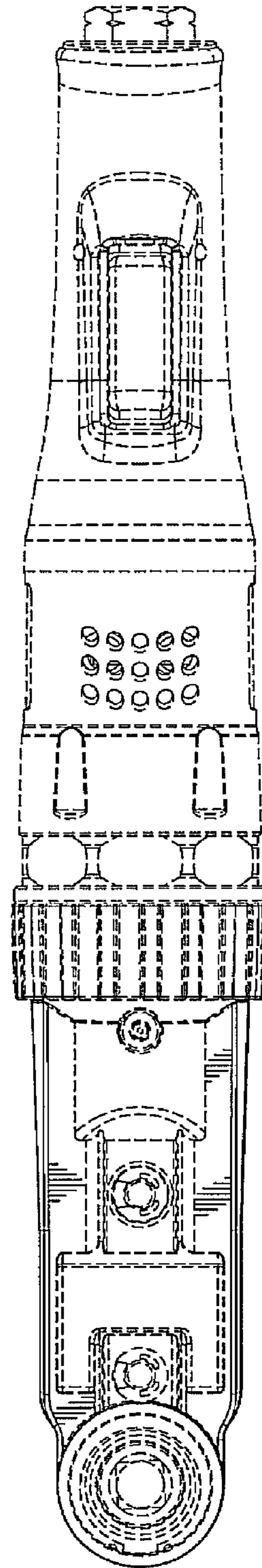

FIG. 7