



US00D727296S

(12) **United States Design Patent**
Hartmann

(10) **Patent No.:** **US D727,296 S**
(45) **Date of Patent:** **** Apr. 21, 2015**

(54) **SPEAKER**

(71) Applicant: **Gibson Brands, Inc.**, Nashville, TN
(US)

(72) Inventor: **Axel Hartmann**, Ravensburg (DE)

(73) Assignee: **Gibson Brands, Inc.**, Nashville, TN
(US)

(**) Term: **14 Years**

(21) Appl. No.: **29/478,547**

(22) Filed: **Jan. 6, 2014**

(51) **LOC (10) Cl.** **14-03**

(52) **U.S. Cl.**
USPC **D14/215**

(58) **Field of Classification Search**
USPC D14/167, 168, 170–172, 188, 194–196,
D14/204, 207, 209.1, 210–216, 219, 221,
D14/222, 224, 496; 181/143, 144, 147, 148,
181/150, 153, 157, 198, 199; 381/300–303,
381/306, 332, 333, 336, 345, 361–364,
381/386–388; 369/6–12

See application file for complete search history.

(56) **References Cited**

U.S. PATENT DOCUMENTS

D268,673 S *	4/1983	Iijima	D14/214
D518,818 S *	4/2006	Motoishi	D14/215
D521,494 S *	5/2006	Koskinen et al.	D14/214
D542,777 S *	5/2007	Sato	D14/215
D628,557 S *	12/2010	Vercelli et al.	D14/215
D657,777 S *	4/2012	Jursch et al.	D14/215
D668,634 S *	10/2012	Suzuki	D14/215

* cited by examiner

Primary Examiner — Keli L Hill

(74) *Attorney, Agent, or Firm* — Bates & Bates, LLC

(57) **CLAIM**

What is claimed is the ornamental design for a speaker, as shown and described.

DESCRIPTION

FIG. 1 is a perspective view of the front of the speaker;
FIG. 2 is a front view of the speaker;
FIG. 3 is a back view of the speaker;
FIG. 4 is a left side view of the speaker;
FIG. 5 is a right side view of the speaker;
FIG. 6 is a top view of the speaker;
FIG. 7 is a bottom view of the speaker; and,
FIG. 8 is an alternative perspective view of the front of the speaker.

The broken lines in FIGS. 1-8 represent the portions of the design that form no part of the claim.

1 Claim, 8 Drawing Sheets

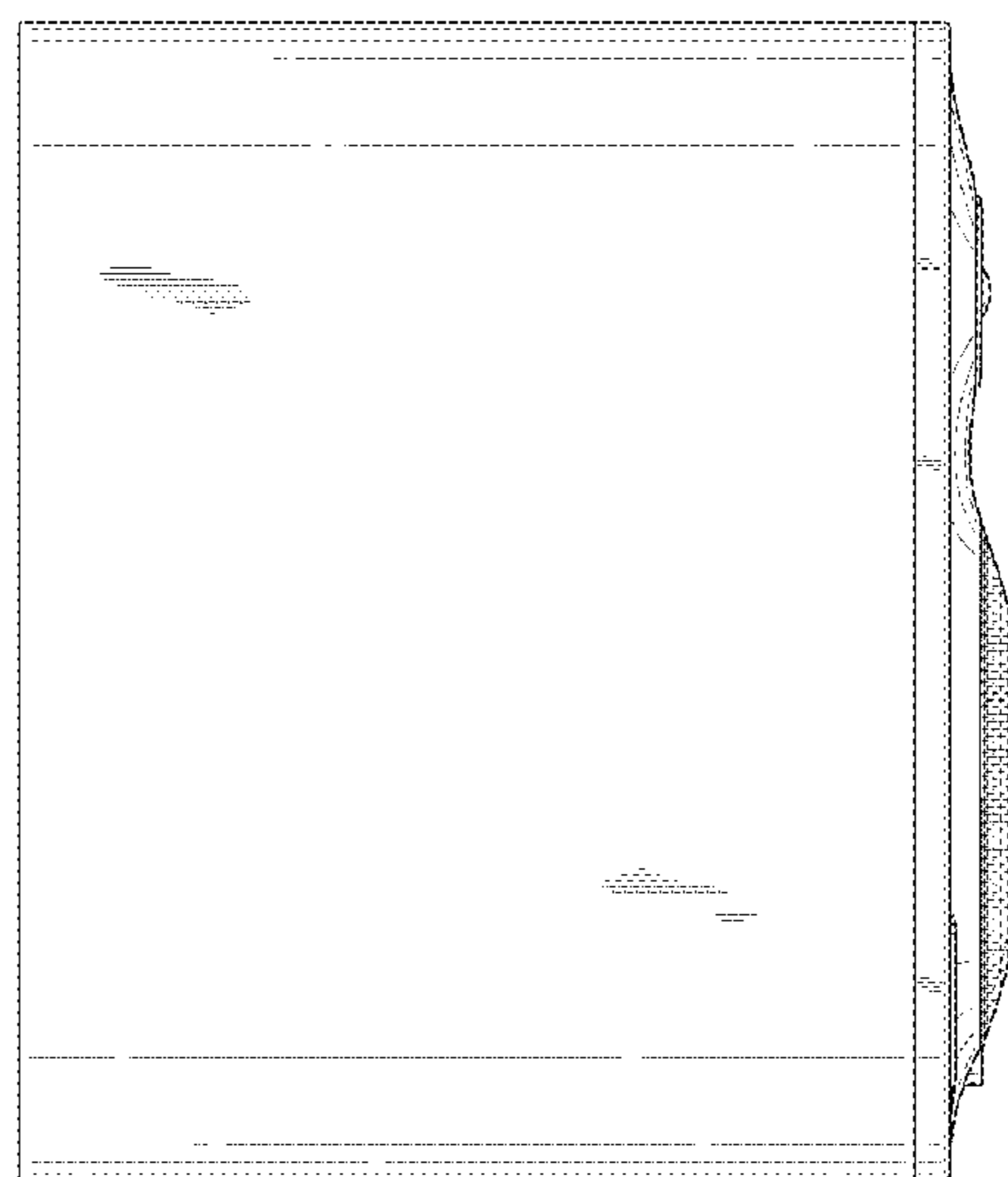
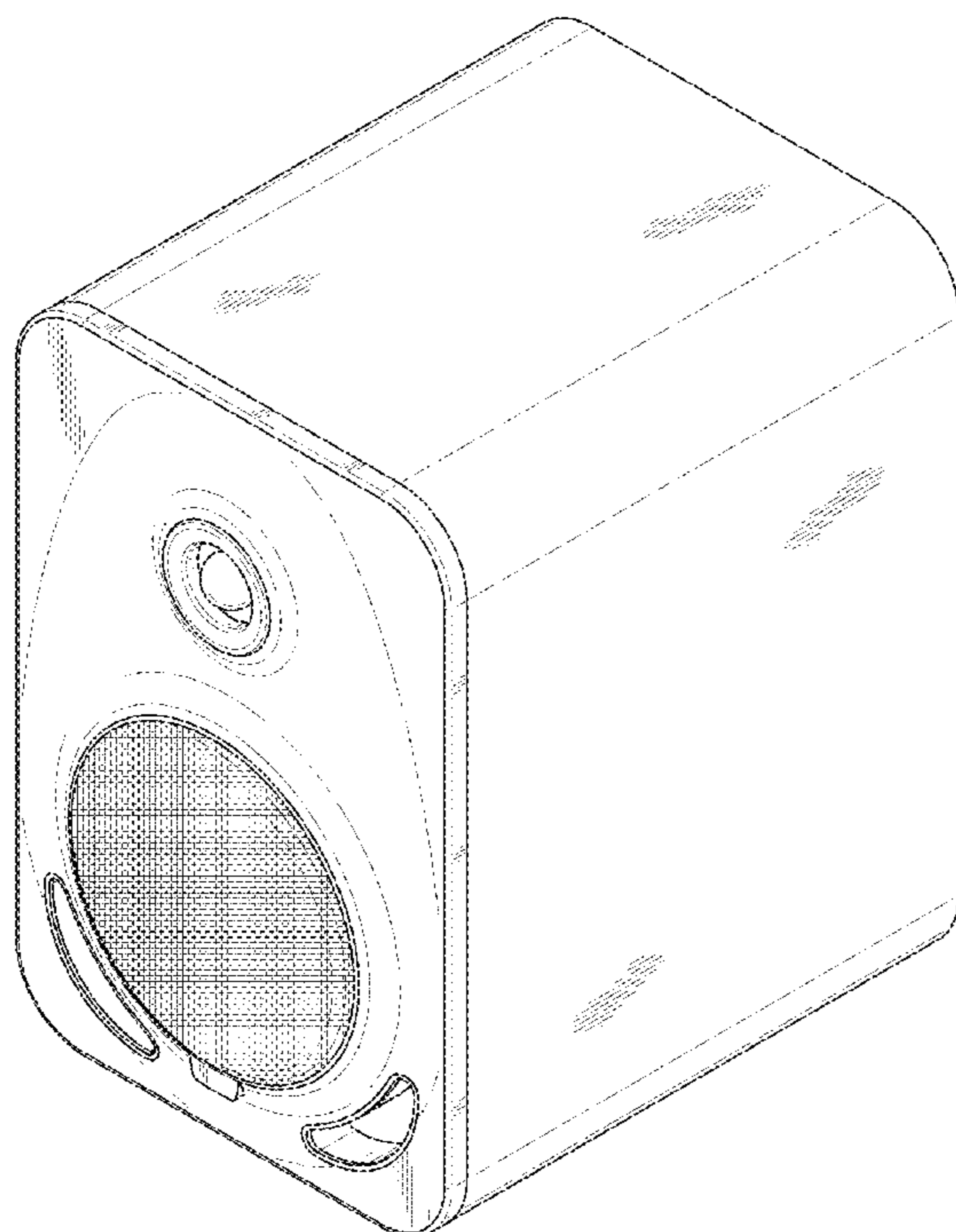

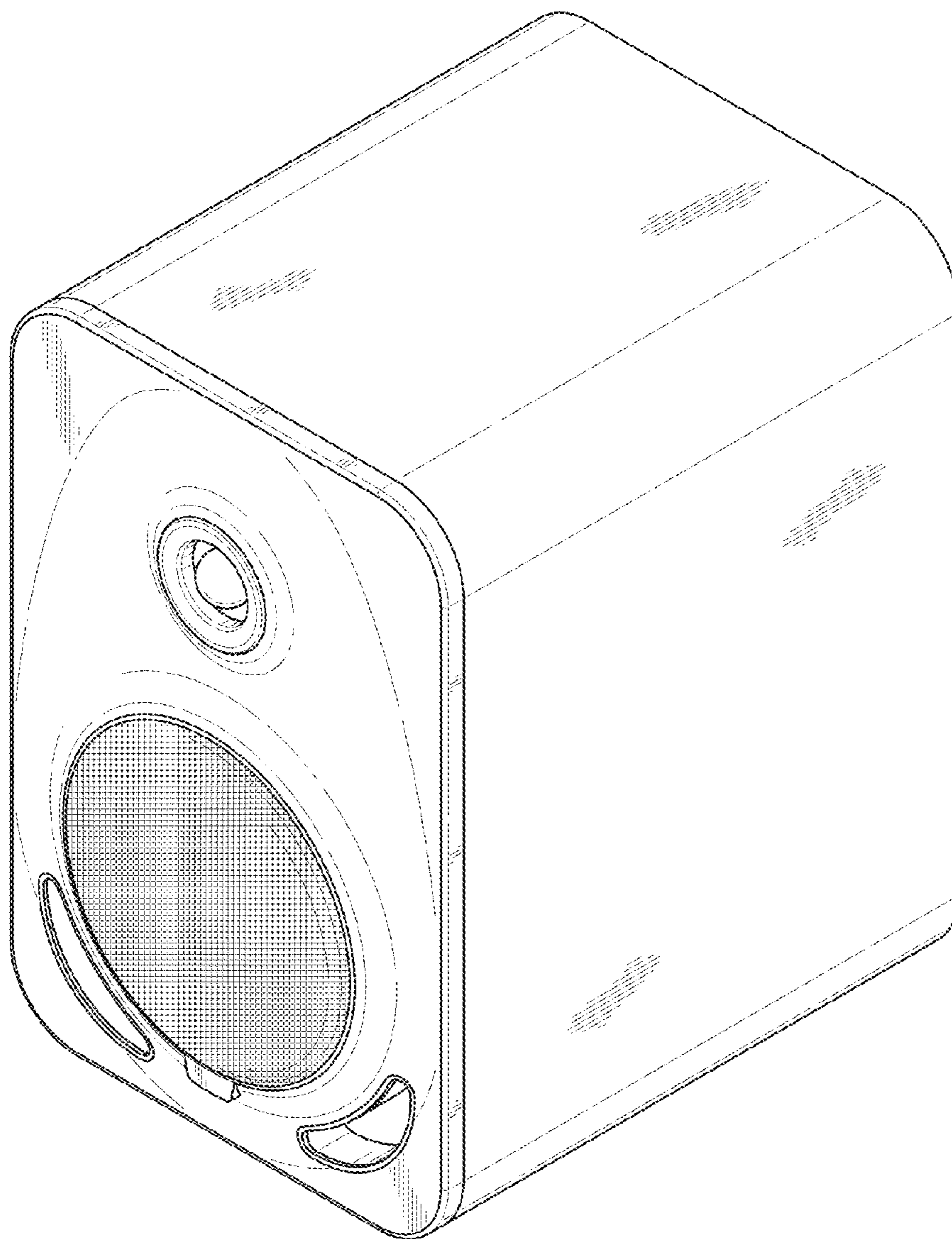

FIG. 1

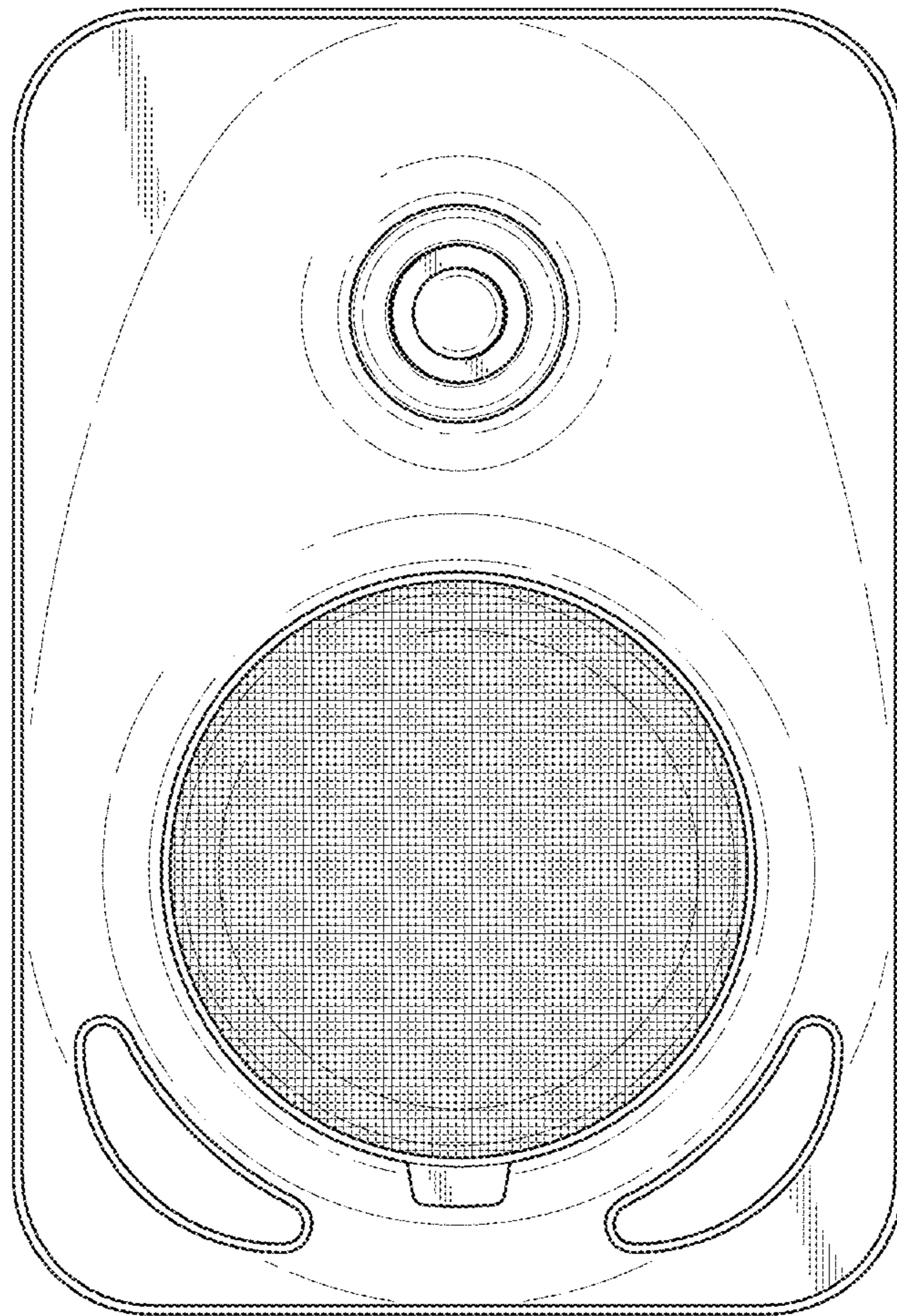

FIG. 2

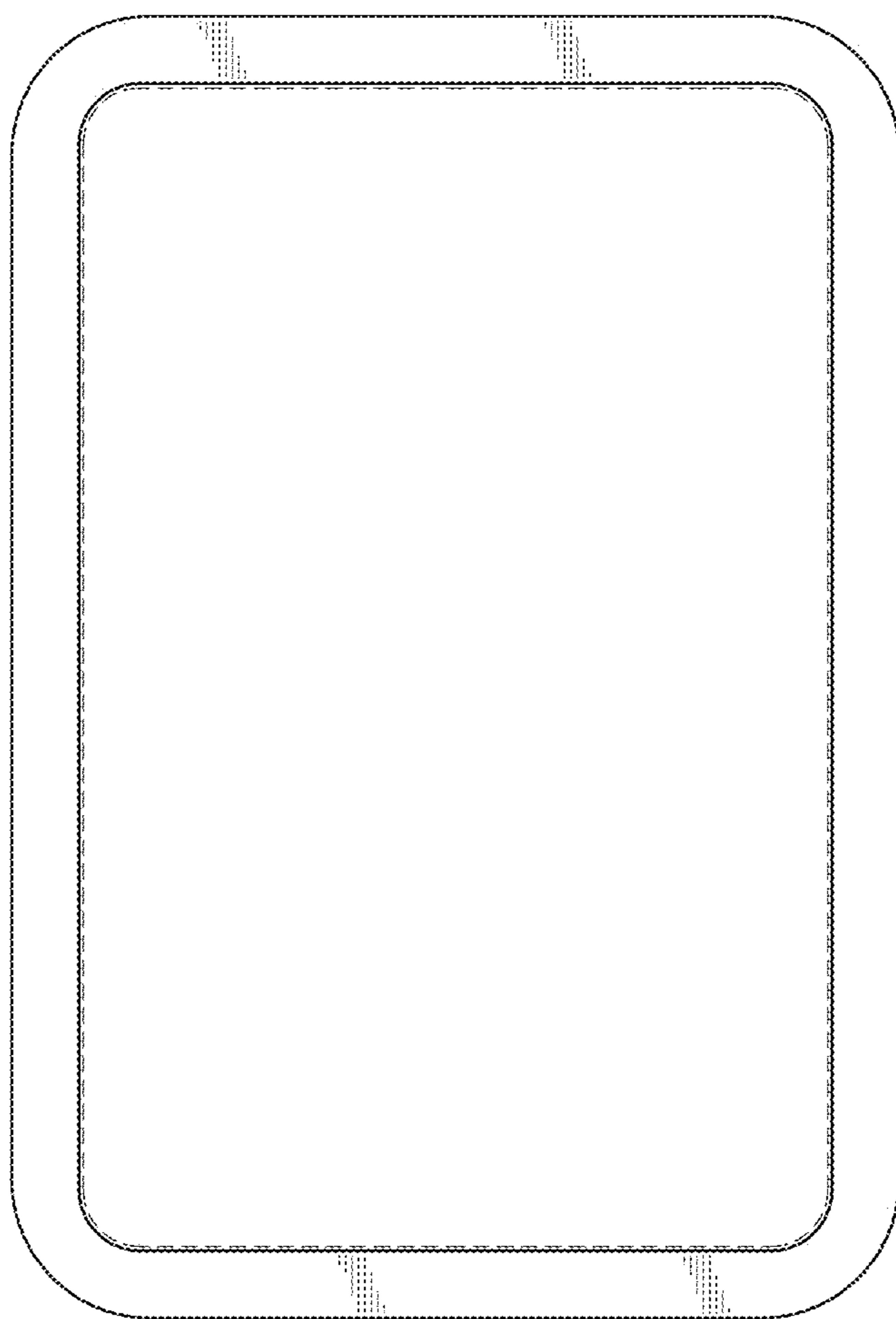

FIG. 3

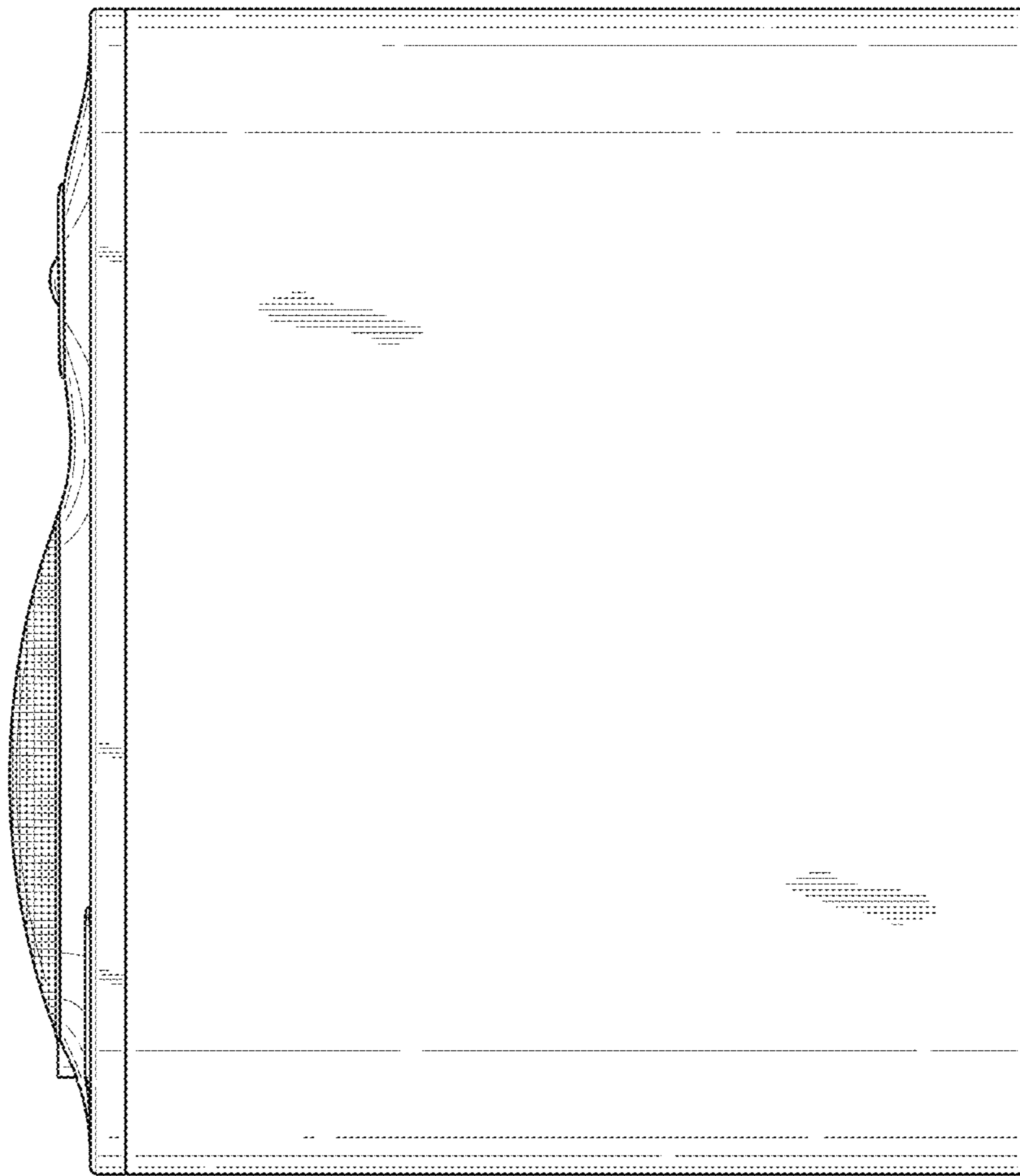

FIG. 4

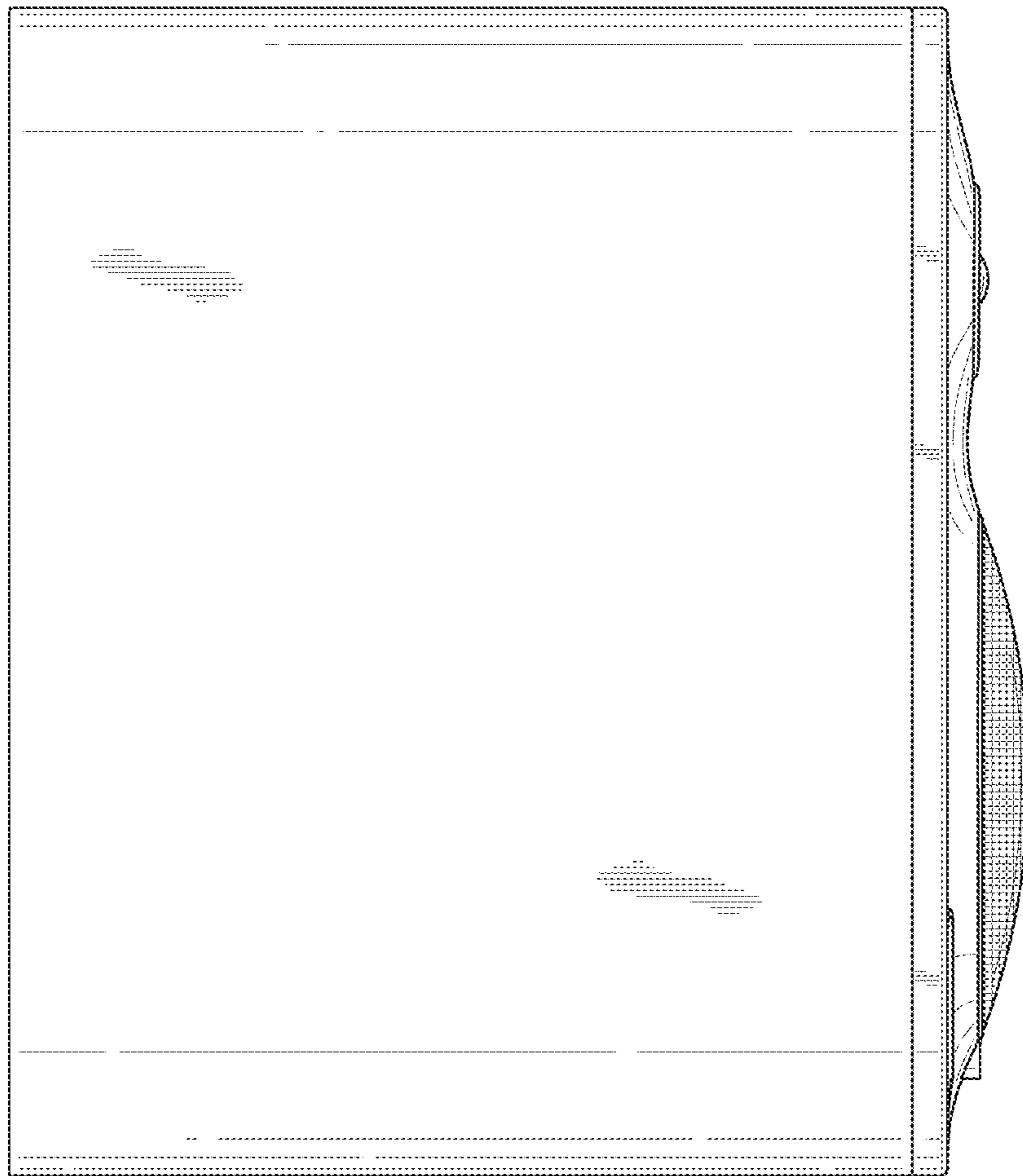

FIG. 5

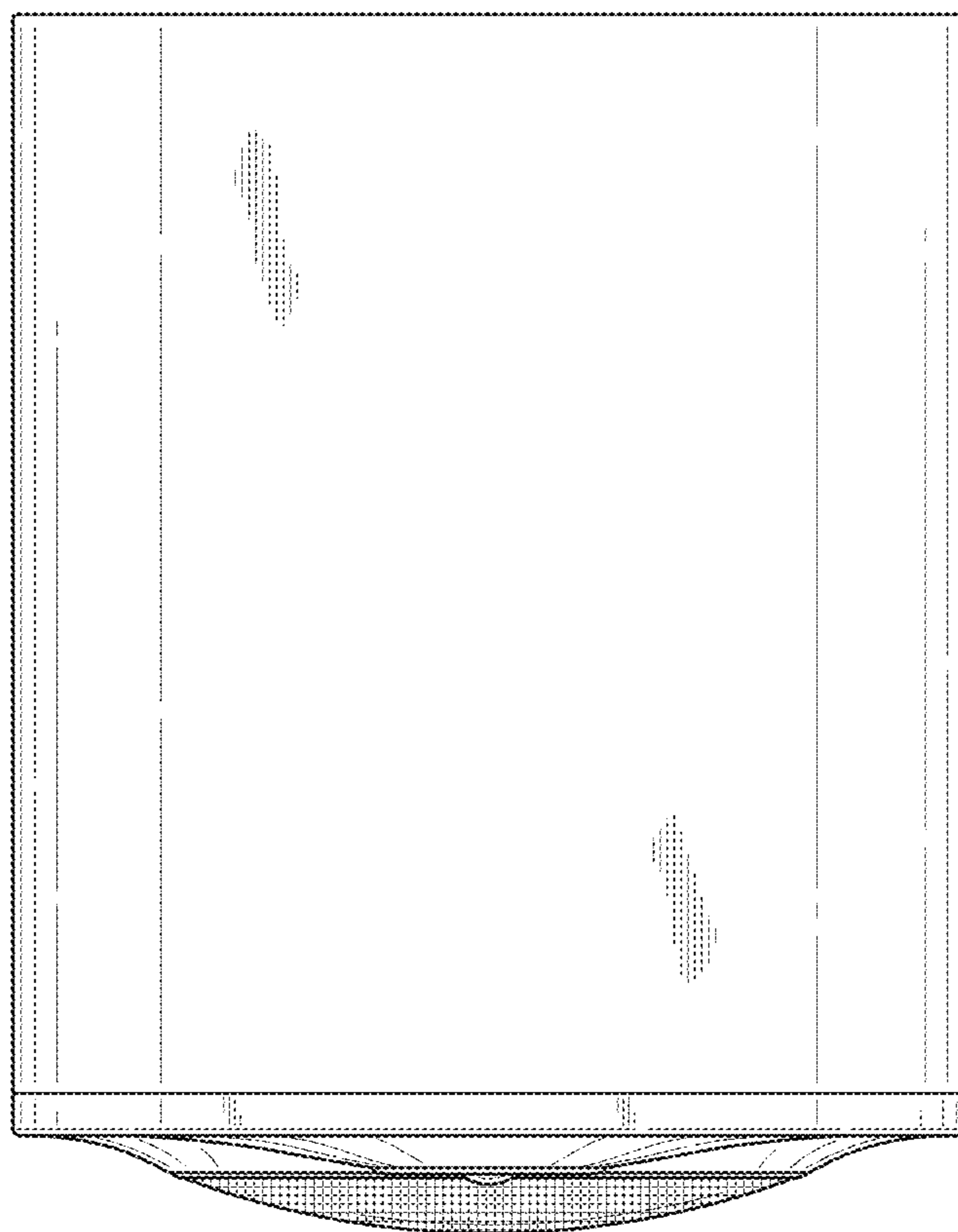

FIG. 6

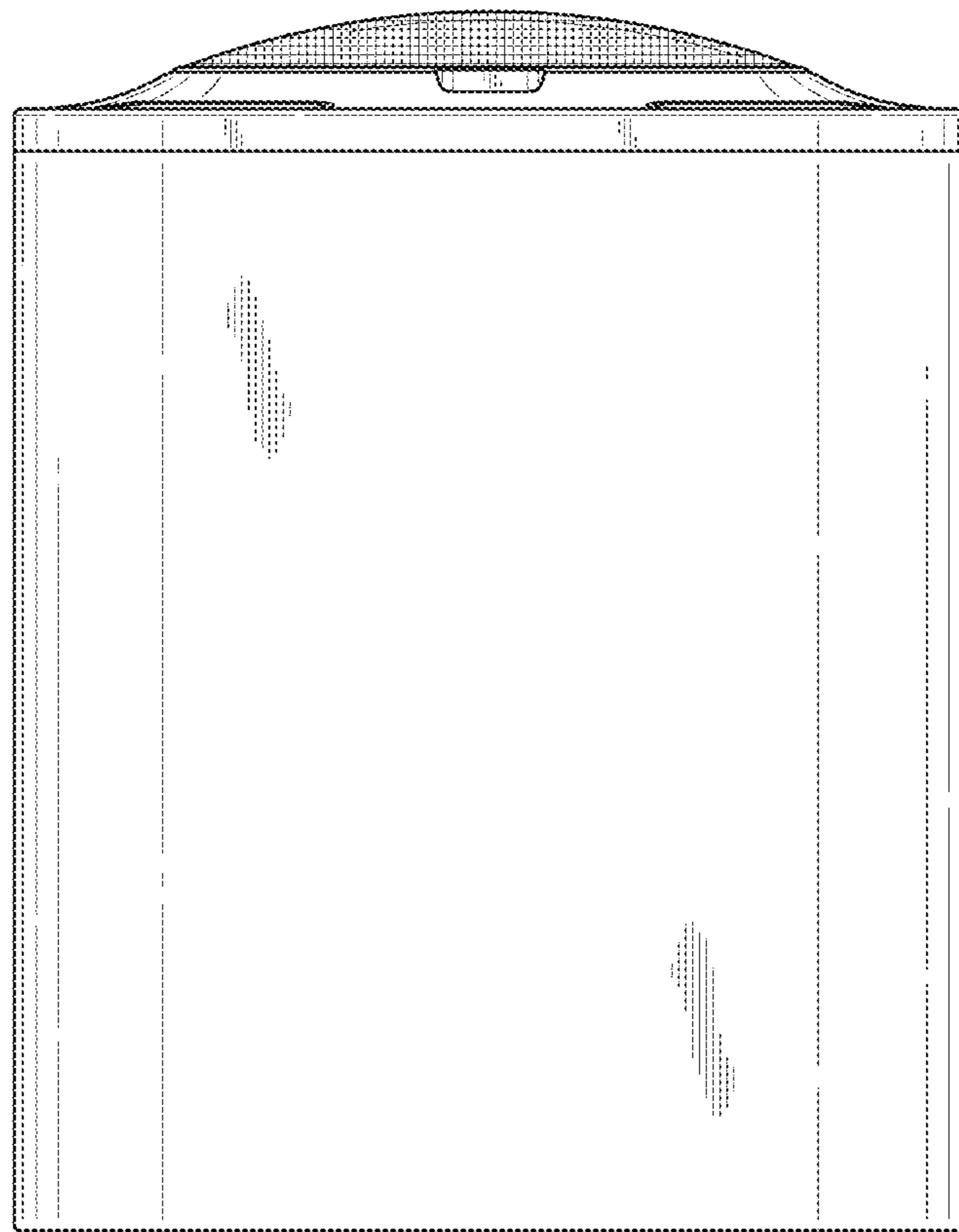

FIG. 7

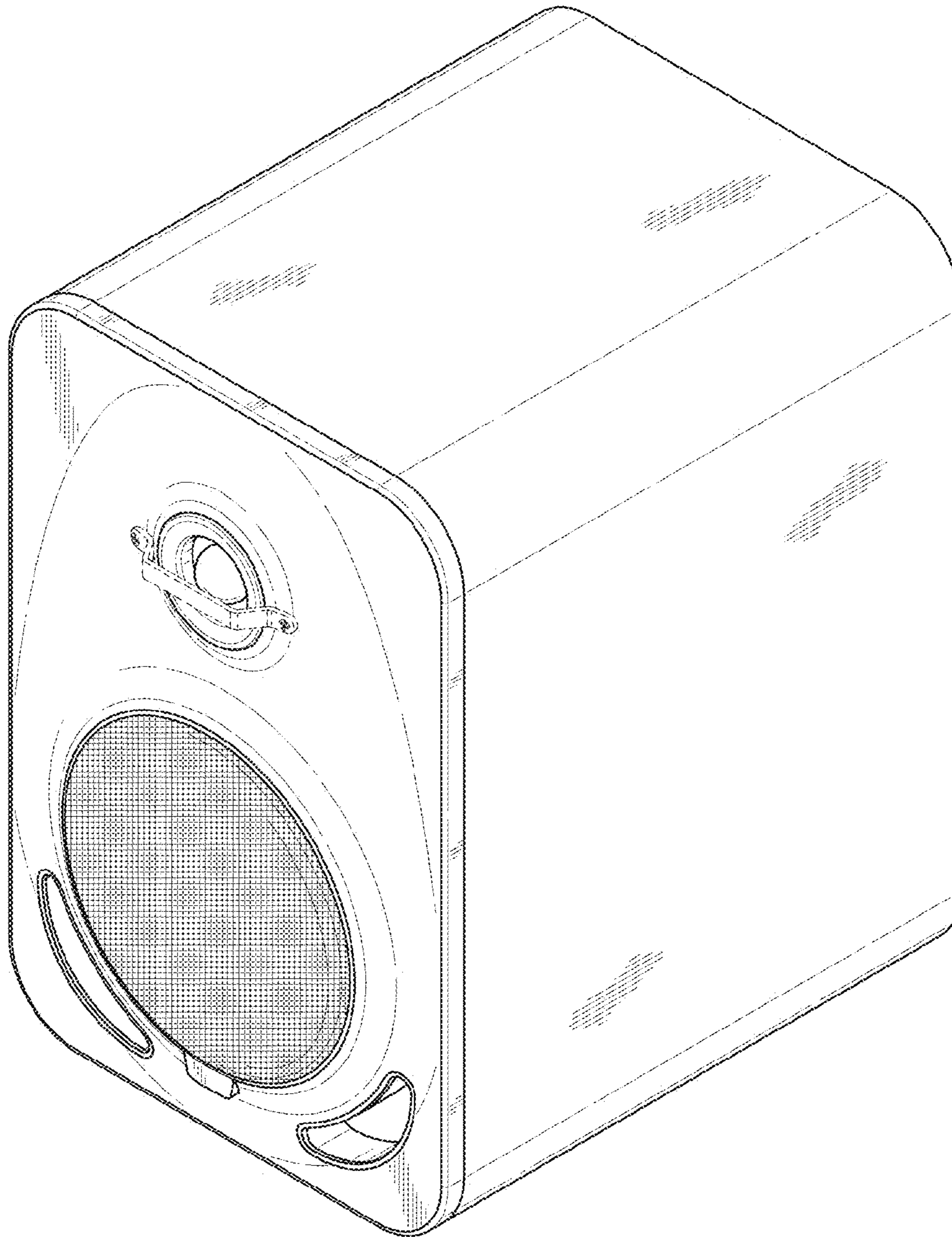

FIG. 8