



US00D727265S

(12) **United States Design Patent**
Kasaba et al.

(10) **Patent No.:** **US D727,265 S**

(45) **Date of Patent:** **** Apr. 21, 2015**

(54) **E-POWER FAST DISCONNECT MODULE**

(71) Applicants: **Michael E. Kasaba**, Camarillo, CA
(US); **Brian Huff**, Newbury Park, CA
(US); **Russell Davis**, Thousand Oaks,
CA (US)

(72) Inventors: **Michael E. Kasaba**, Camarillo, CA
(US); **Brian Huff**, Newbury Park, CA
(US); **Russell Davis**, Thousand Oaks,
CA (US)

(73) Assignee: **Artisan Vehicle Systems, Inc.**,
Camarillo, CA (US)

(**) Term: **14 Years**

(21) Appl. No.: **29/442,967**

(22) Filed: **Jun. 20, 2013**

(51) **LOC (10) Cl.** **13-03**

(52) **U.S. Cl.**
USPC **D13/146**

(58) **Field of Classification Search**
USPC D13/146, 147, 154, 184, 199
See application file for complete search history.

(56) **References Cited**

U.S. PATENT DOCUMENTS

D306,716	S	*	3/1990	Shimirak	D13/147
D333,293	S	*	2/1993	Ashida	D13/147
D344,714	S	*	3/1994	Kulbersh	D13/147
D372,460	S	*	8/1996	Aramaki	D13/147
D412,489	S	*	8/1999	Middlehurst et al.	D13/147
D658,586	S	*	5/2012	Lin	D13/146
D684,538	S	*	6/2013	Akana et al.	D13/147
D699,186	S	*	2/2014	Suzuki et al.	D13/146

* cited by examiner

Primary Examiner — Daniel Bui

(57) **CLAIM**

The ornamental design for an E-power fast disconnect module, as shown and described.

DESCRIPTION

FIG. 1 is a top view of an E-power fast disconnect module showing our new design;
FIG. 2 is a left side view thereof;
FIG. 3 is a front side view thereof;
FIG. 4 is a right side view thereof;
FIG. 5 is a bottom side view thereof;
FIG. 6 is a front, top perspective view thereof; and,
FIG. 7 is a front, bottom perspective view thereof.

1 Claim, 2 Drawing Sheets

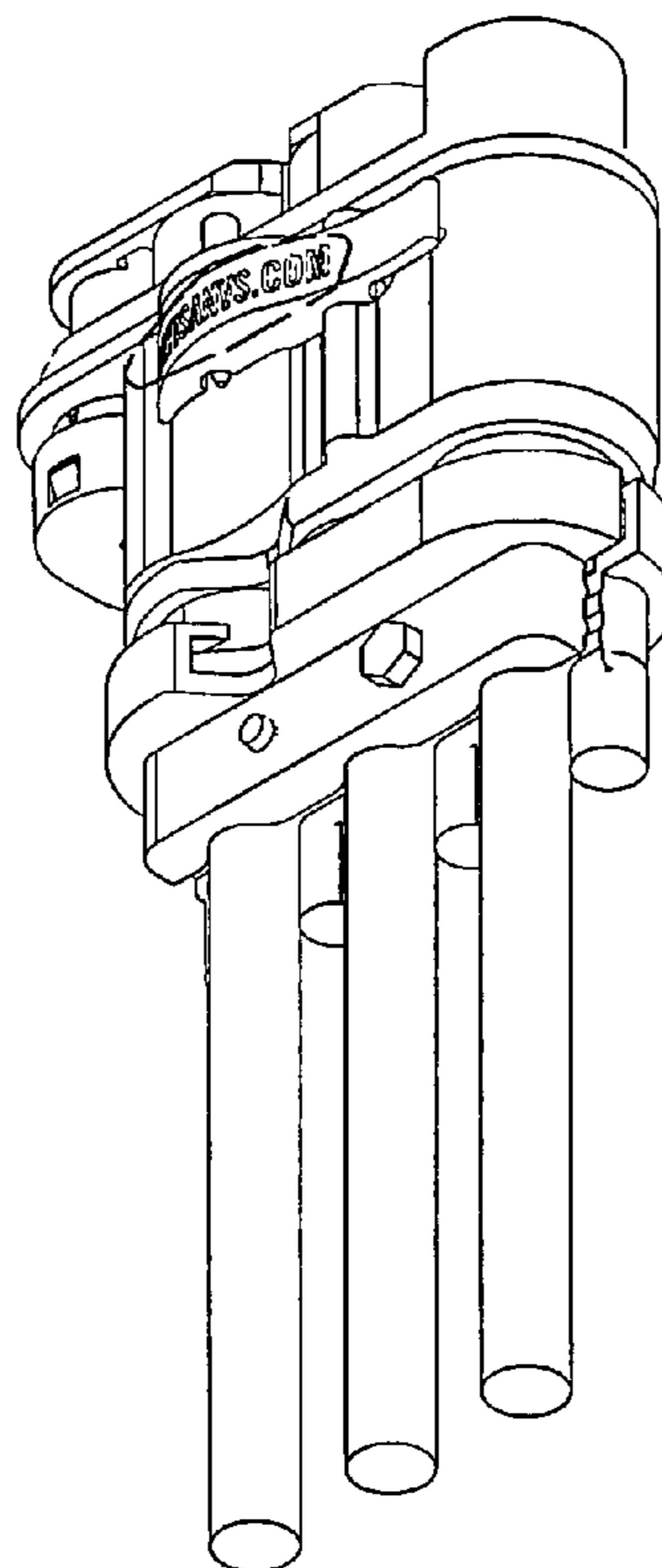
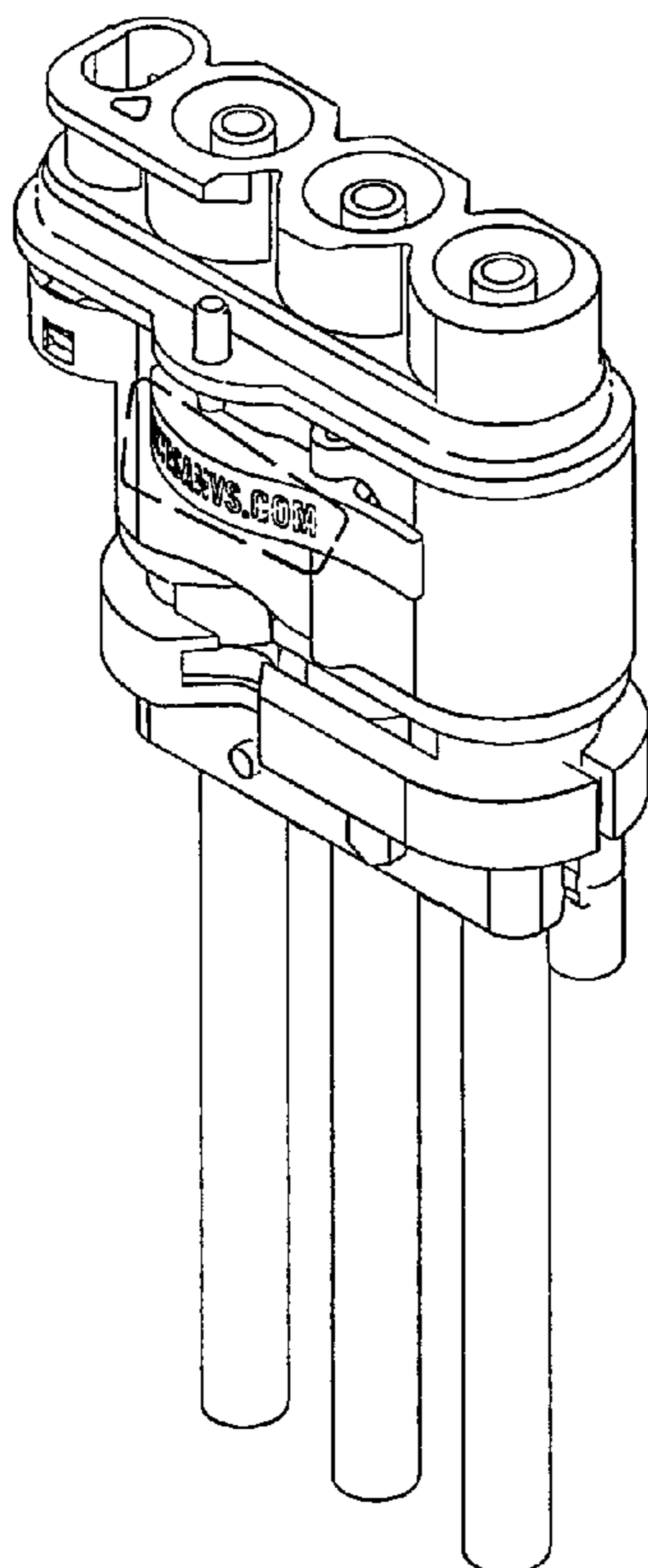

FIG. 1

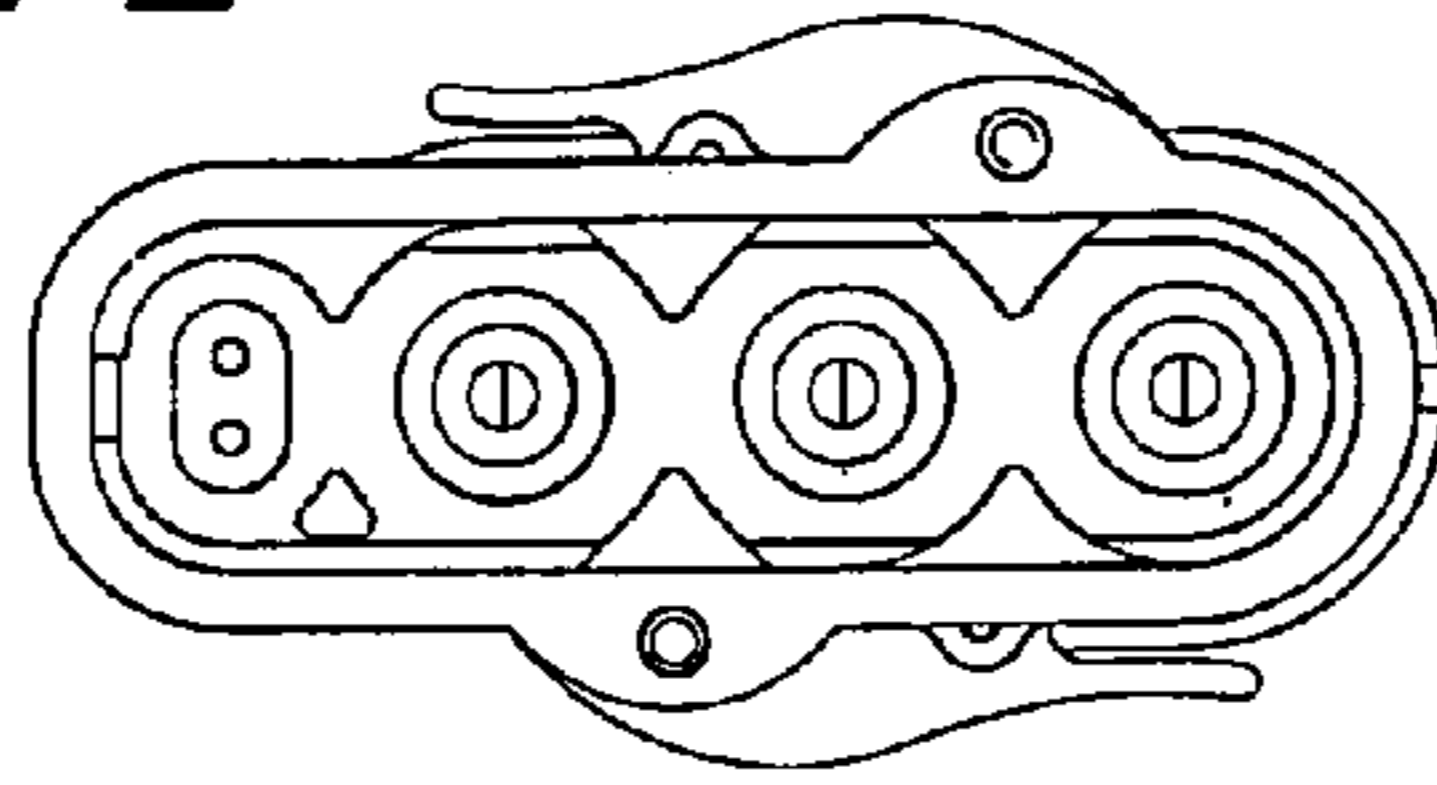

FIG. 2

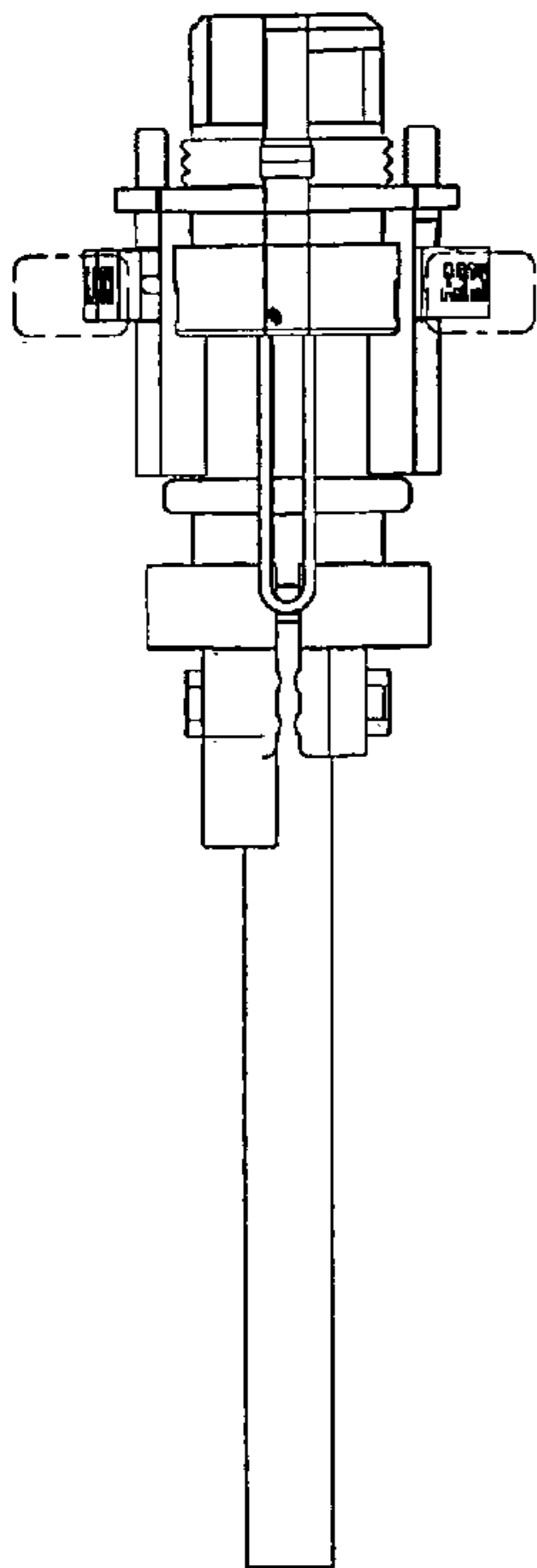

FIG. 3

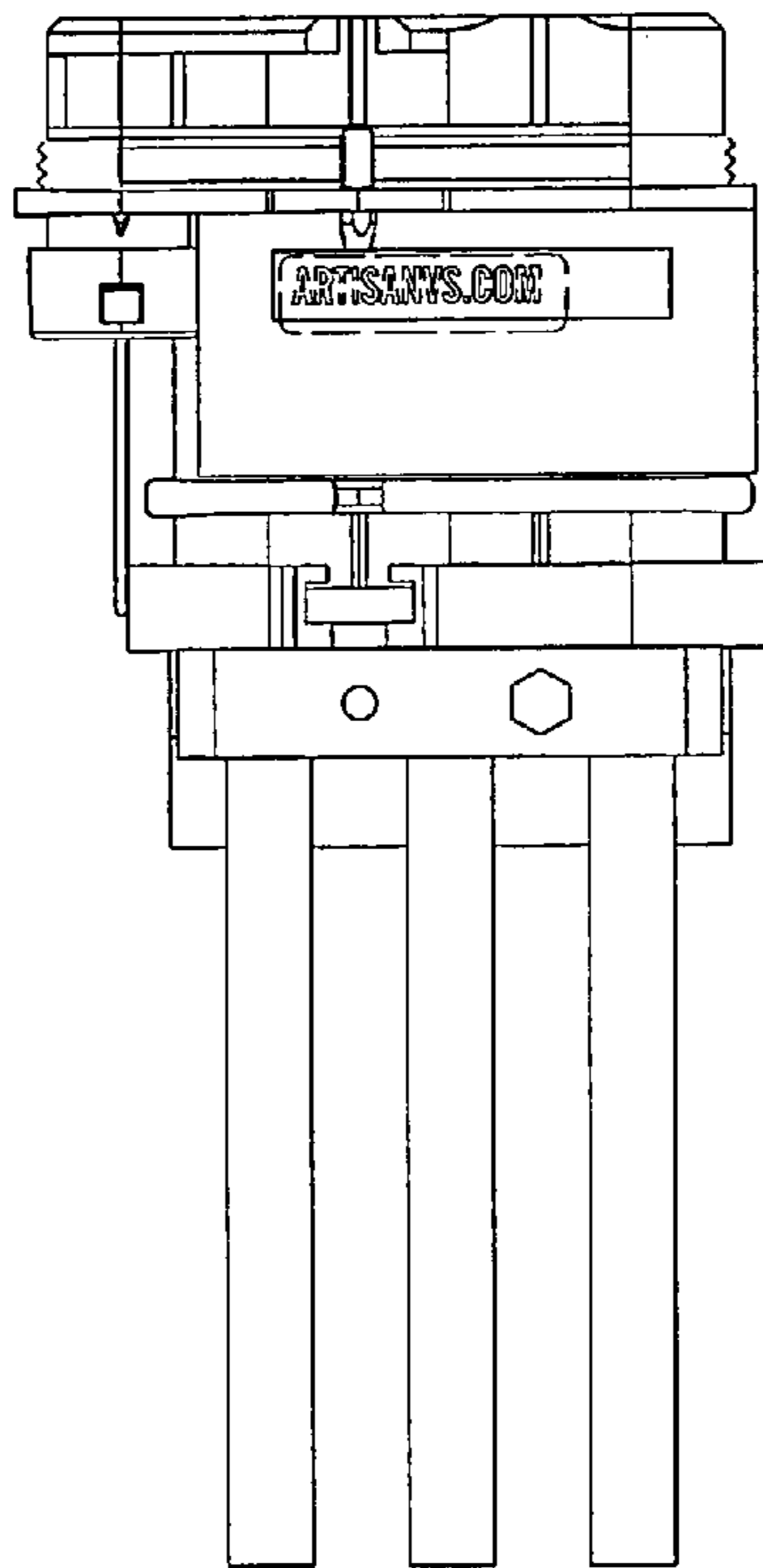

FIG. 4

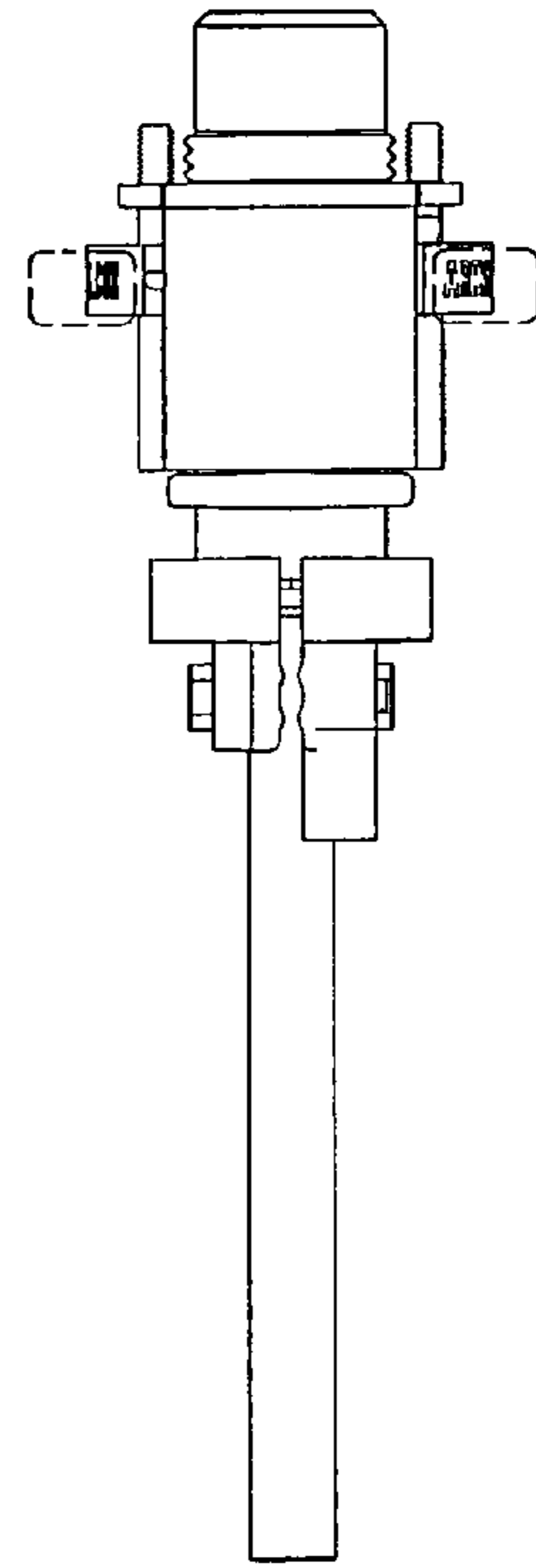
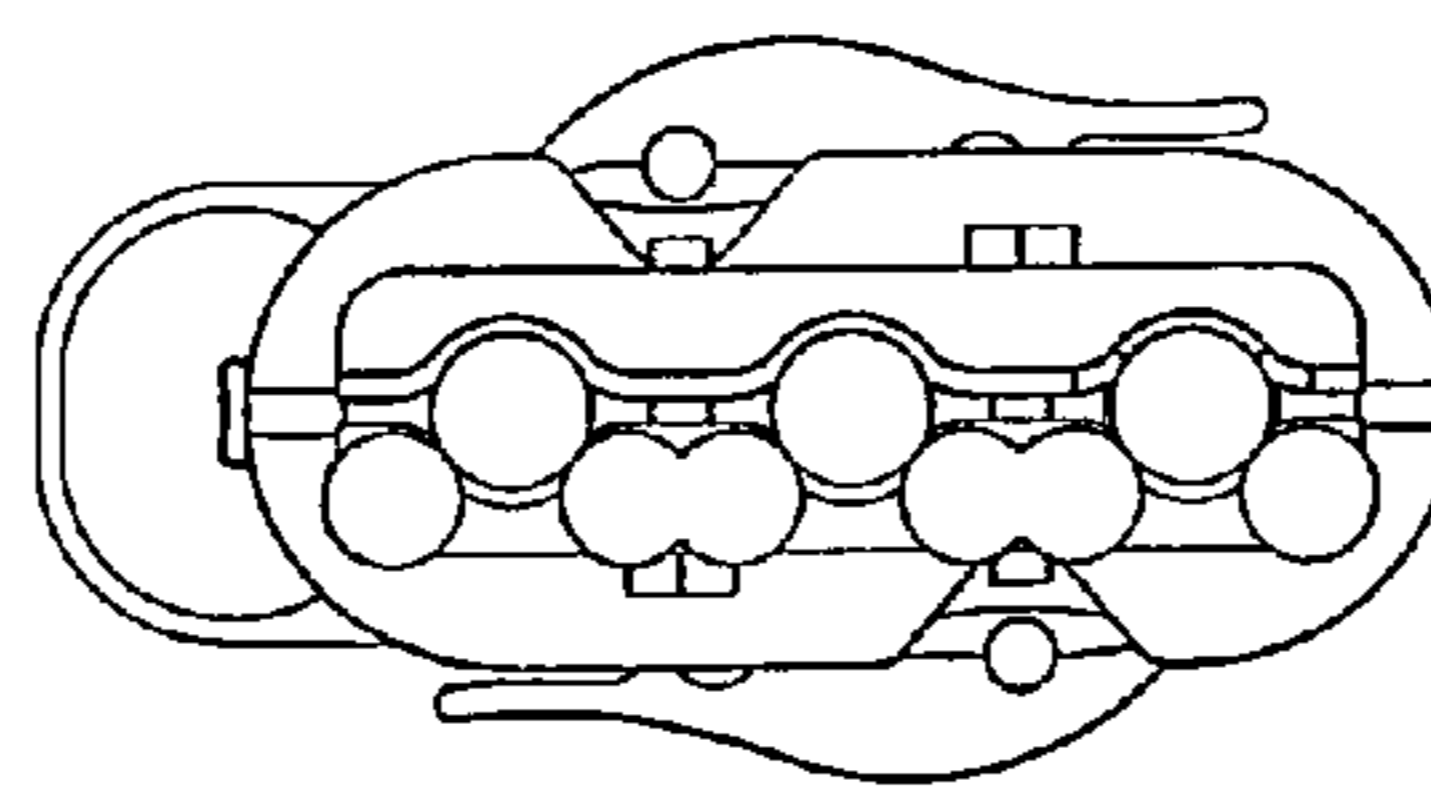

FIG. 5



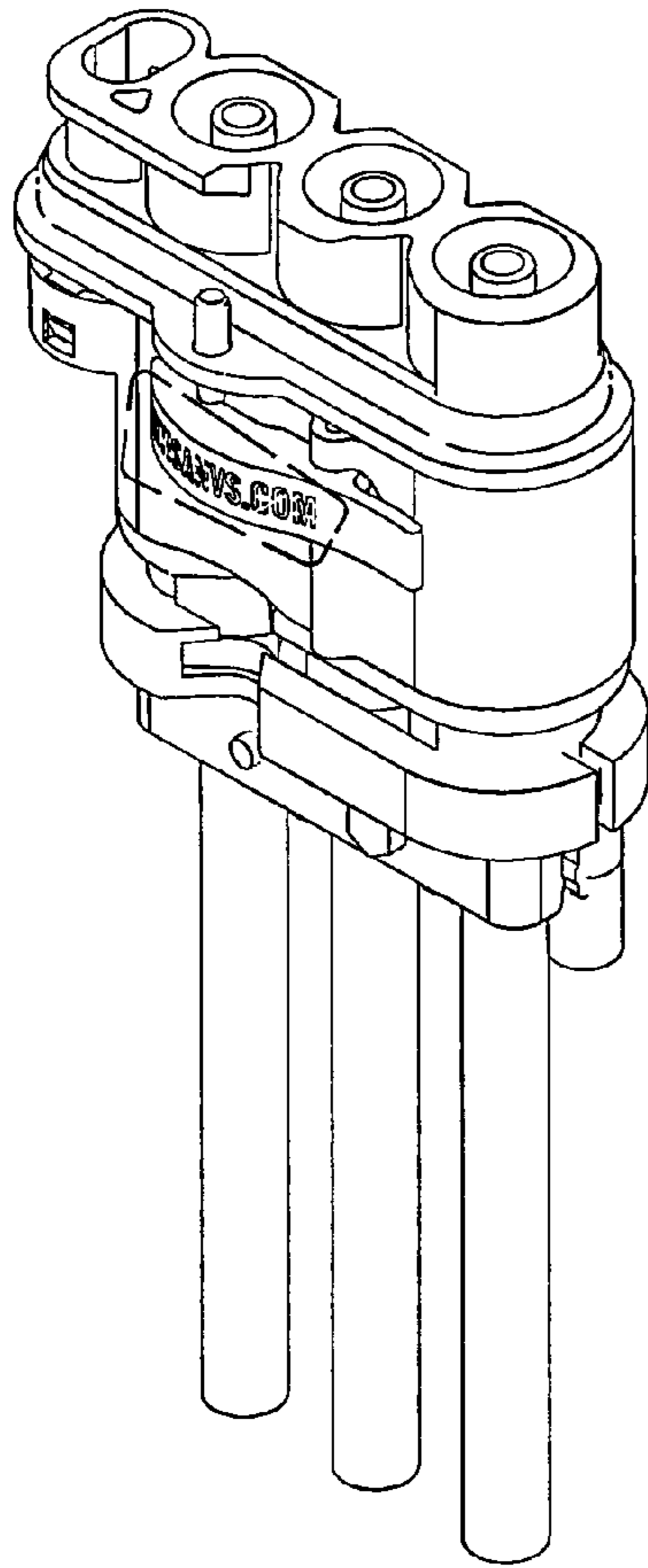

FIG. 6

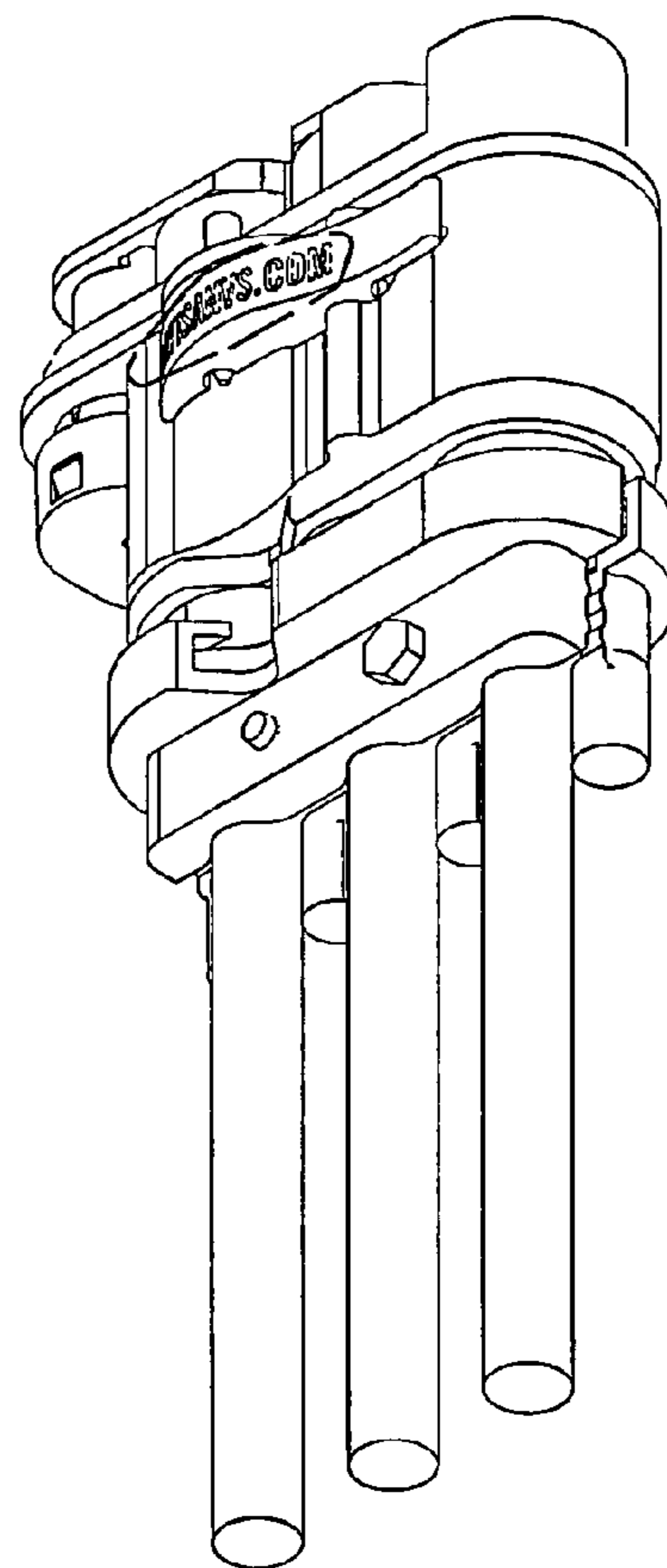

FIG. 7