



US00D727264S

(12) **United States Design Patent**  
**Schmid**

(10) **Patent No.:** **US D727,264 S**

(45) **Date of Patent:** **\*\* Apr. 21, 2015**

(54) **NACELLE FOR A WIND TURBINE**

(75) **Inventor:** **Jonas Schmid**, Westerstede (DE)

(73) **Assignee:** **Aloys Wobben**, Aurich (DE)

(\*\*) **Term:** **14 Years**

(21) **Appl. No.:** **29/403,240**

(22) **Filed:** **Oct. 3, 2011**

(30) **Foreign Application Priority Data**

Apr. 4, 2011 (DE) ..... 40 2011 001 848

(51) **LOC (10) Cl.** ..... **13-01**

(52) **U.S. Cl.**  
USPC ..... **D13/115**

(58) **Field of Classification Search**  
USPC ..... D13/115, 118, 122, 199; D12/319, 344,  
D12/345; D15/1, 199; D21/458; 290/44, 52,  
290/54, 55; 415/2.1, 4.2, 4.5, 7, 907, 916;  
416/7, 16, 24, 31, 37, 38, 132 B, 132 R,  
416/141, 142, 176, 177, 196 A, 243;  
D23/377, 379, 413  
See application file for complete search history.

(56) **References Cited**

**U.S. PATENT DOCUMENTS**

D252,572 S	8/1979	Hanson	.....	D15/1
4,449,682 A	5/1984	Gratzer et al.	.....	244/130
5,653,406 A	8/1997	Amano et al.	.....	244/130
D517,986 S	3/2006	Wobben	.....	D13/115
D535,388 S *	1/2007	Gajewski	.....	D23/413
D584,686 S *	1/2009	Gudewer	.....	D13/115
D587,649 S *	3/2009	Gudewer	.....	D13/115
D602,861 S *	10/2009	Talab	.....	D13/115
D639,239 S	6/2011	Gudewer et al.	.....	D13/115
D639,240 S	6/2011	Gudewer et al.	.....	D13/115
2002/0153728 A1	10/2002	Groppel	.....	290/44
2003/0123973 A1	7/2003	Murakami	.....	415/4.1

2004/0057828 A1 *	3/2004	Bosche	.....	416/1
2004/0201220 A1	10/2004	Andersen et al.	.....	290/44
2005/0072067 A1 *	4/2005	Wobben	.....	52/155

**FOREIGN PATENT DOCUMENTS**

DE	40109165.1	10/2001
JP	1342211	10/2008

**OTHER PUBLICATIONS**

“A10—New Concept Wind Power Generator,” Luso, 1 page, Mar. 2003.

“Dehn schützt Windenergieanlagen. Dehn protects Wind Turbines,” Dehn + Söhne, brochure, 10 pages, Mar. 2003.

“E-53,” retrieved Aug. 11, 2008, from <http://www.enercon.de/www/en/e53.nsf/04CA674831391E59C1256E89002FE760/3CDB...>, 1 page.

“E-112 Egelin Feb. 2005.jpg,” Image, retrieved Aug. 11, 2008, from [http://commons.wikipedia.org/wiki/Image:E-112\\_Egelin\\_Feb.2005.jpg](http://commons.wikipedia.org/wiki/Image:E-112_Egelin_Feb.2005.jpg), 3 pages.

(Continued)

*Primary Examiner* — Derrick Holland

(74) *Attorney, Agent, or Firm* — Seed IP Law Group PLLC

(57) **CLAIM**

The ornamental design for a nacelle for a wind turbine, as shown and described.

**DESCRIPTION**

FIG. 1 is an isometric view of a nacelle for a wind turbine, showing my new design.

FIG. 2 is a front elevational view thereof.

FIG. 3 is a right side elevational view thereof.

FIG. 4 is a left side elevational view thereof.

FIG. 5 is a rear elevational view thereof.

FIG. 6 is a top plan view thereof; and,

FIG. 7 is a bottom plan view thereof.

The broken lines shown represent unclaimed subject matter and form no part of the claimed design.

**1 Claim, 7 Drawing Sheets**

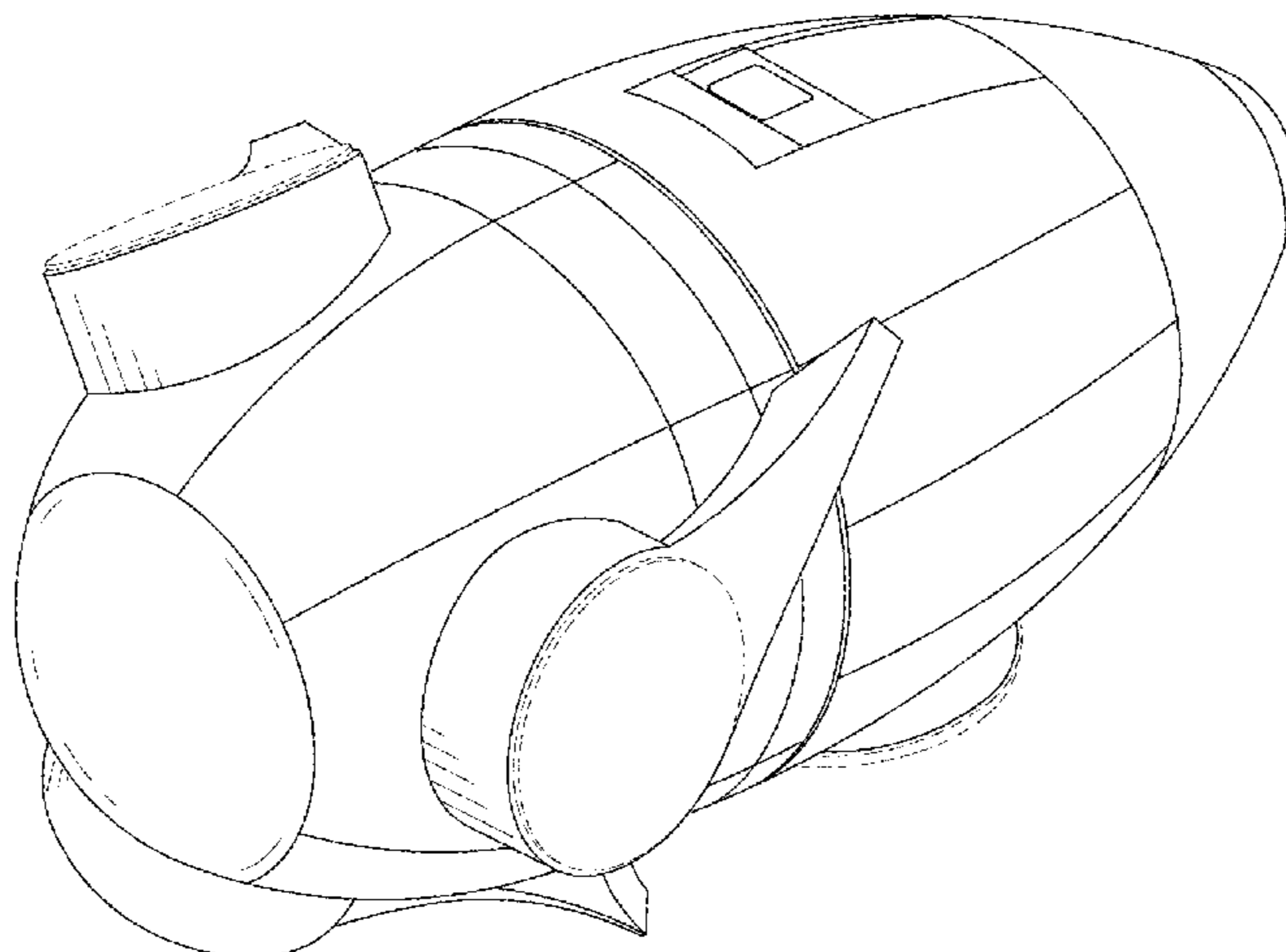

(56)

**References Cited**

## OTHER PUBLICATIONS

“Elements Special Dewind magazine,” DeWind Magazine, 48 pages, Aug. 2002.

“Enercon\_e0070,” retrieved Sep. 26, 2008, from <http://www.flickr.com/photos/jeroen8/244414019>, 1 page.

Enercon, Dewind, Lagerwey, and Suzlon, brochure, 2 pages, Mar. 2003.

“Enercon E-30 Aurich Okt 2004.PNG,” Image, retrieved Aug. 11, 2008, from [http://commons.wikimedia.org/wiki/Image:Enercon\\_E-30\\_Aurich\\_Okt\\_2004.PNG](http://commons.wikimedia.org/wiki/Image:Enercon_E-30_Aurich_Okt_2004.PNG), 3 pages.

“Erosionsschutzfolie für Windenergieanlagen 3M™ Polyurethanfilm 8671,” 3M Innovation, leaflet, 2 pages, Mar. 2003.

“GE Wind Energy 3.6 Offshore Multi-Megawatt Wind Turbine,” GE Wind Energy, brochure, 20 pages, Mar. 2003.

Hau, “Windkraftanlagen—Grundlagen, Technik, Einsatz, Wirtschaftlichkeit,” Springer-Verlag, Berlin, Heidelberg, Germany, 1988 and 1996, pp. 8-9, 26-28, 31, 38-39, 48-49, 51, 511-515, 579-580, 600. (15 pages).

“J48 Innovative wind turbine,” Jeumont Framatome ANP, brochure, 6 pages, Mar. 2003.

“Komponenten, Netzinfrastrukturen and Managed Services für Windparks,” RWE Solutions, brochure, 20 pages, Mar. 2003.

“N50/800 kW Leading technology for first-class outputs,” Nordex, brochure, 6 pages, Feb. 2002.

“N80/2500 kW N90/2300 kW Mit Höchstleistung in die Zukunft,” Nordex, brochure, 6 pages, Feb. 2002.

“[Optimaler Auftrieb in jedem Klima] [NM54/950 Power-Trim],” N-E-G Micon, brochure, 5 pages, Mar. 2003.

“Powering a Greener Tomorrow,” Suzlon, brochure, 11 pages, Mar. 2003.

“S70/1500 kW S77/1500 kW Perfekte Technologie für jeden Standort,” Nordex, brochure, 6 pages, Feb. 2002.

“S70/1500 kW S77/1500 kW The perfect technology for each location,” Nordex, brochure, 6 pages, Feb. 2002.

“Suzlon 1000kW Megapower Powering a Greener Tomorrow,” Suzlon, brochure, 4 pages, Mar. 2003.

“Suzlon Megapower Series,” Suzlon, brochure, 27 pages, Mar. 2003.

“Suzlon Wind Power Powering a Greener Tomorrow,” Suzlon, brochure, 11 pages, Mar. 2003.

“Vibration engineering,” Scanvib, 1 page, Mar. 2003.

“Wind Turbine,” retrieved Sep. 26, 2008, from <http://www.flickr.com/photos/hddod/141018303>, 2 pages.

“WindMan® Express [Kontroll- und Überwachungssysteme für kleinere Windenergieanlagen] [Die Verbindung zu Ihrer Windturbine],” N-E-G Micon, brochure, Mar. 2003.

\* cited by examiner

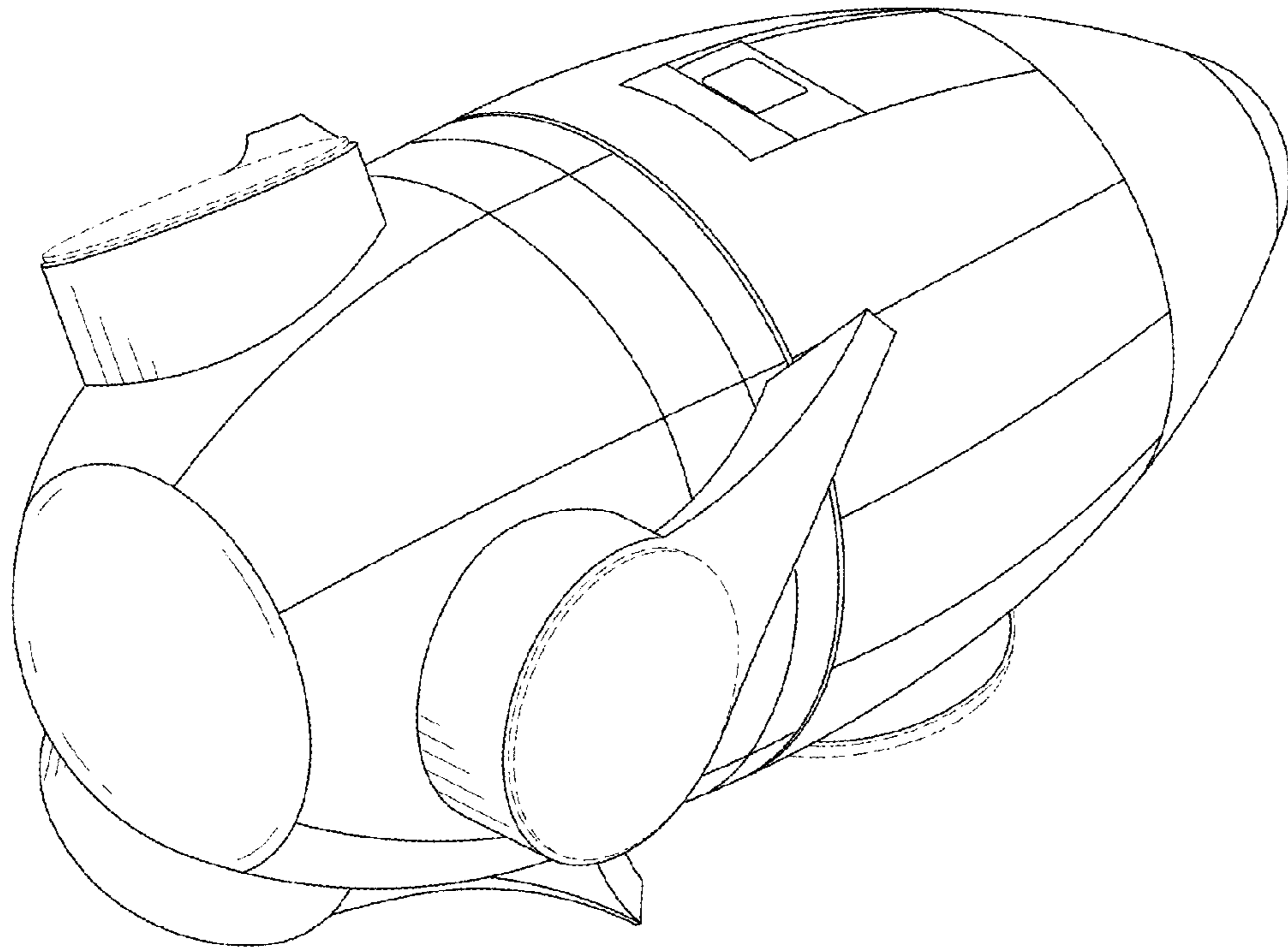

*FIG. 1*

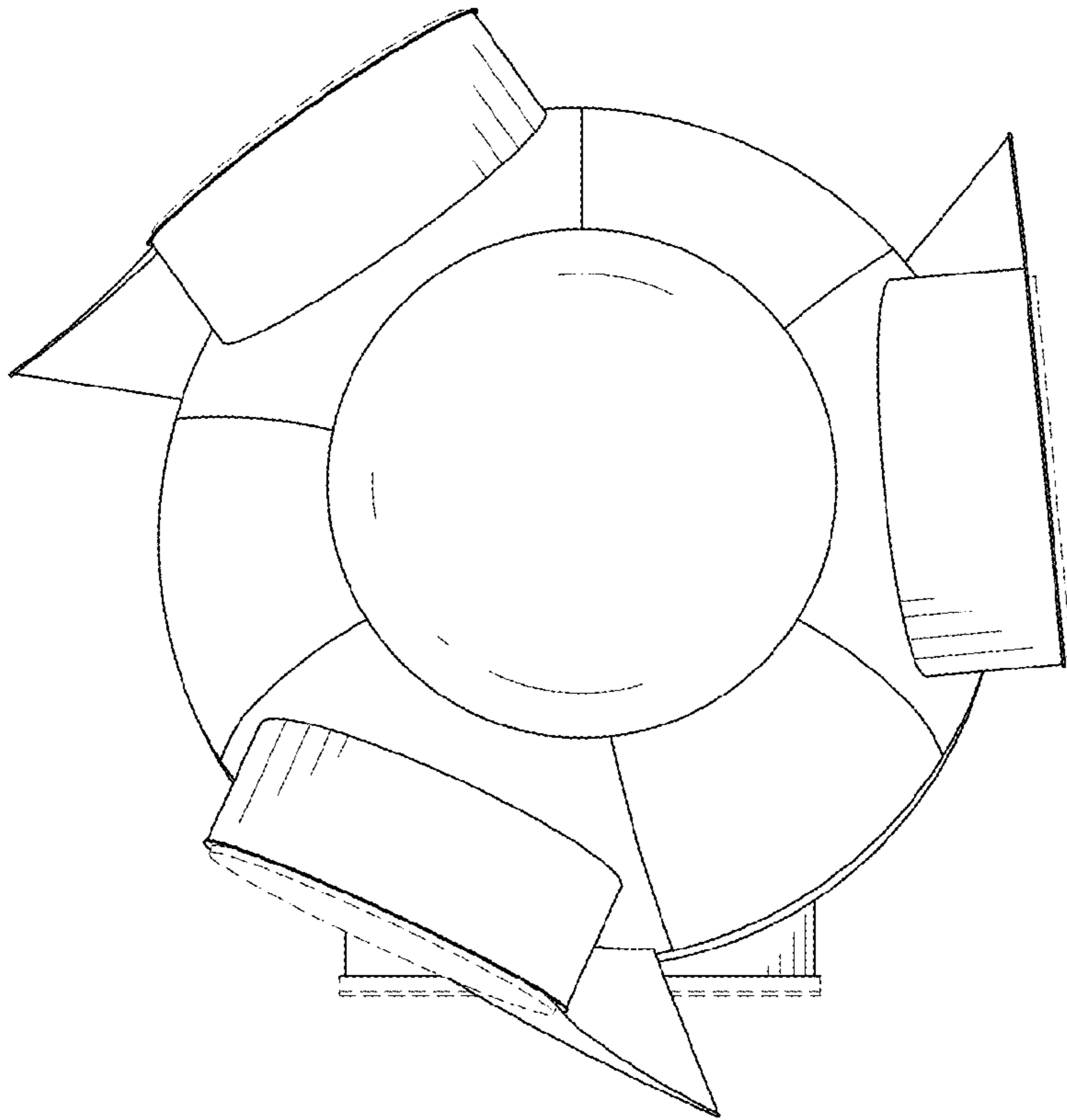

*FIG. 2*

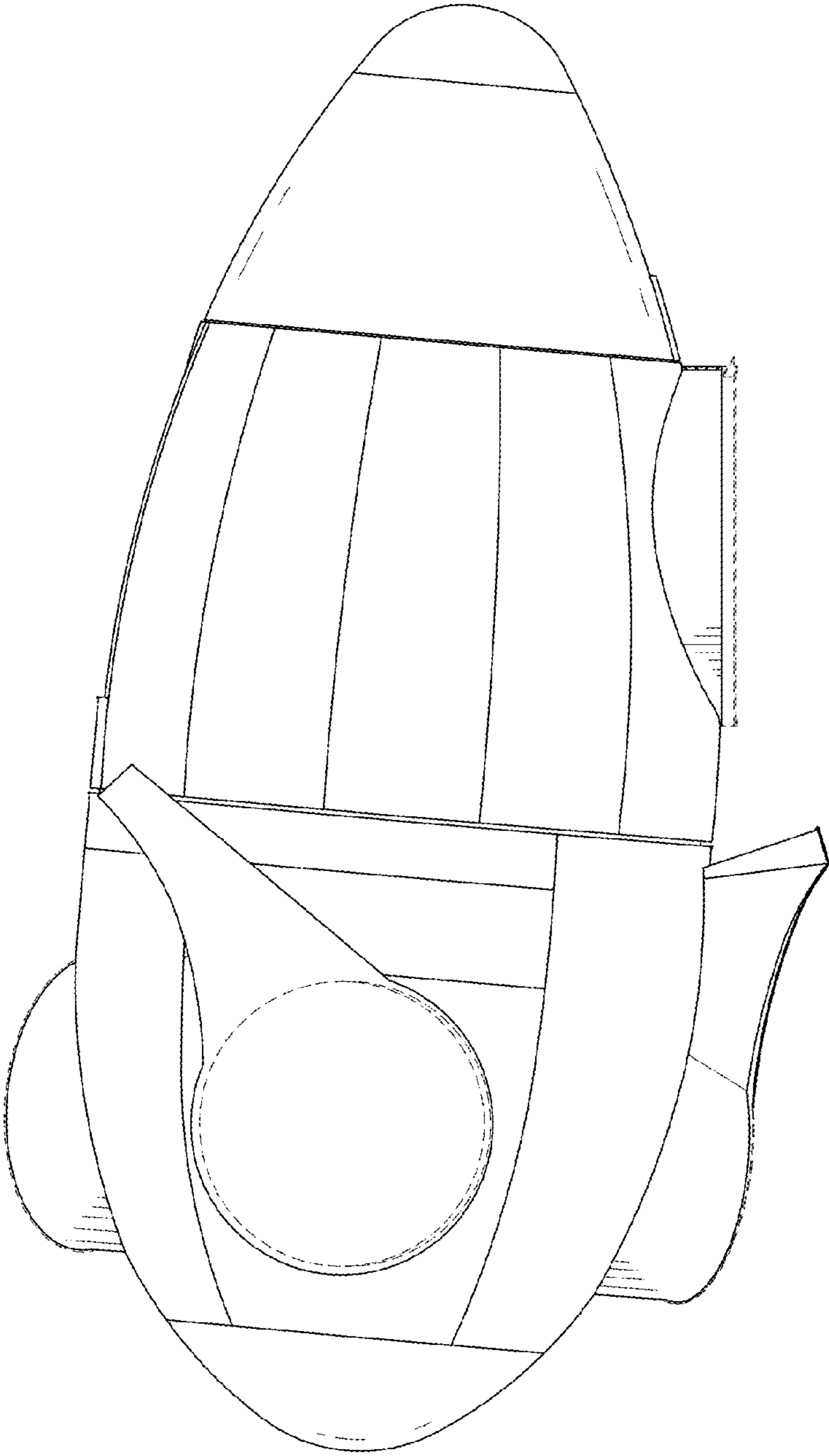

FIG. 3



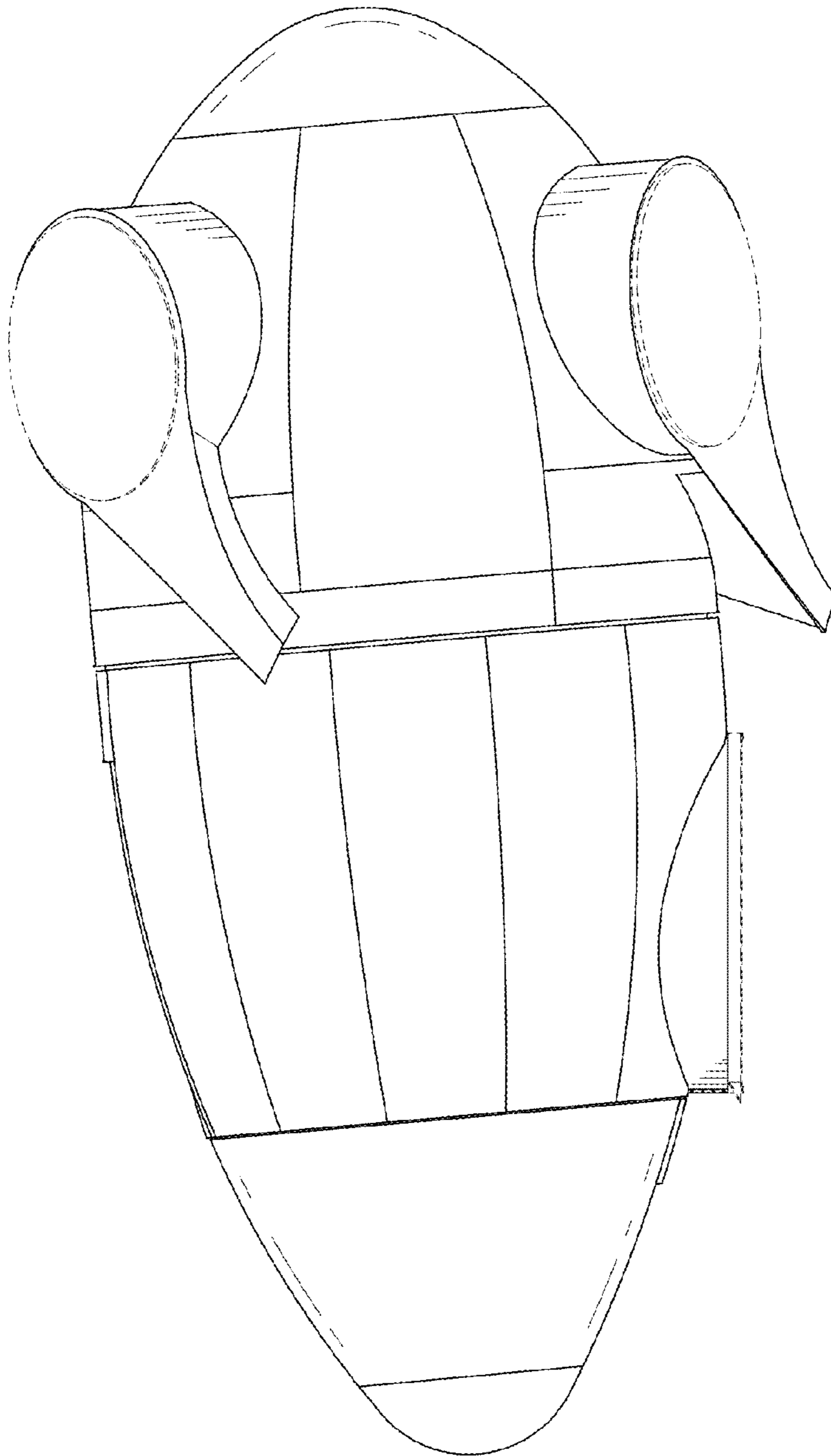
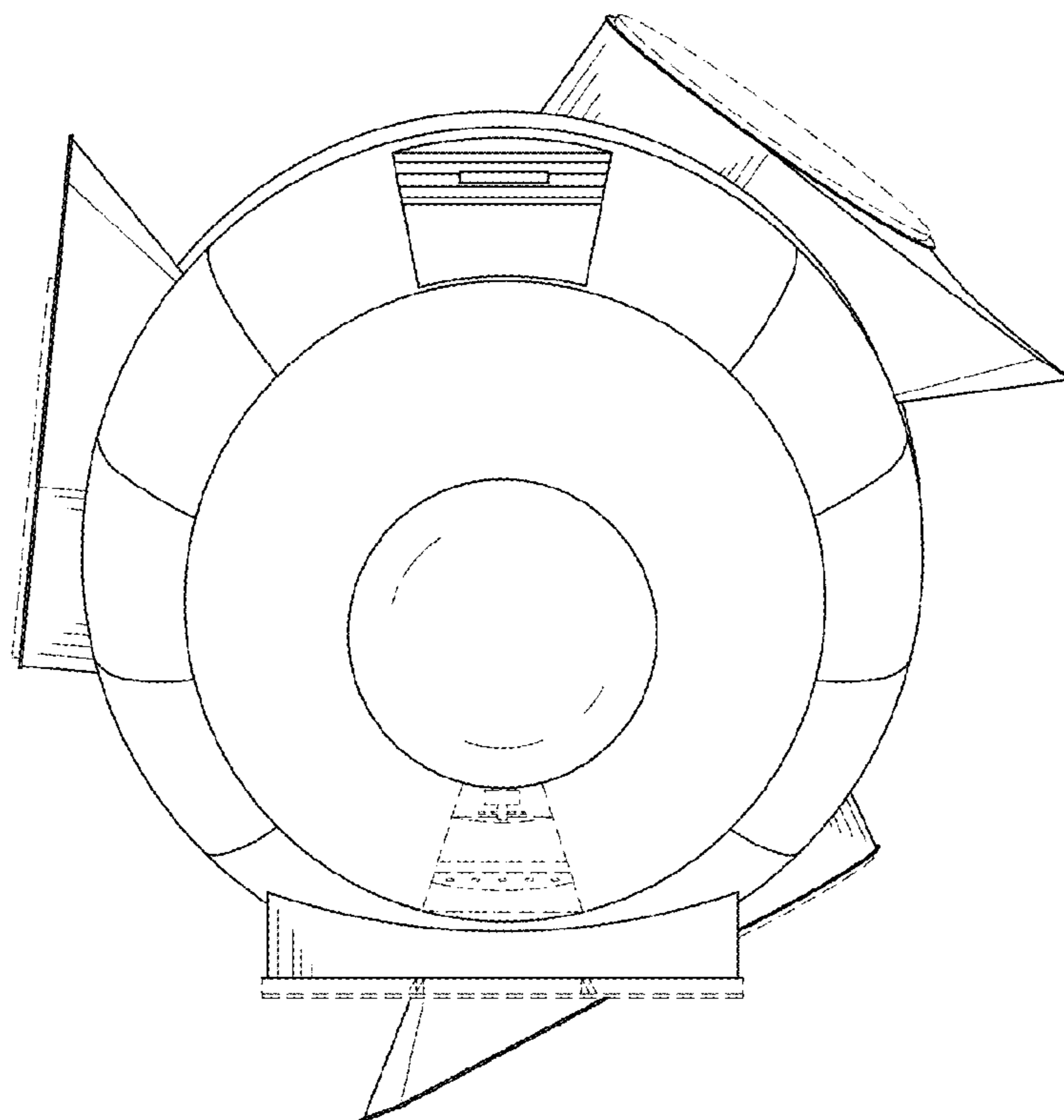
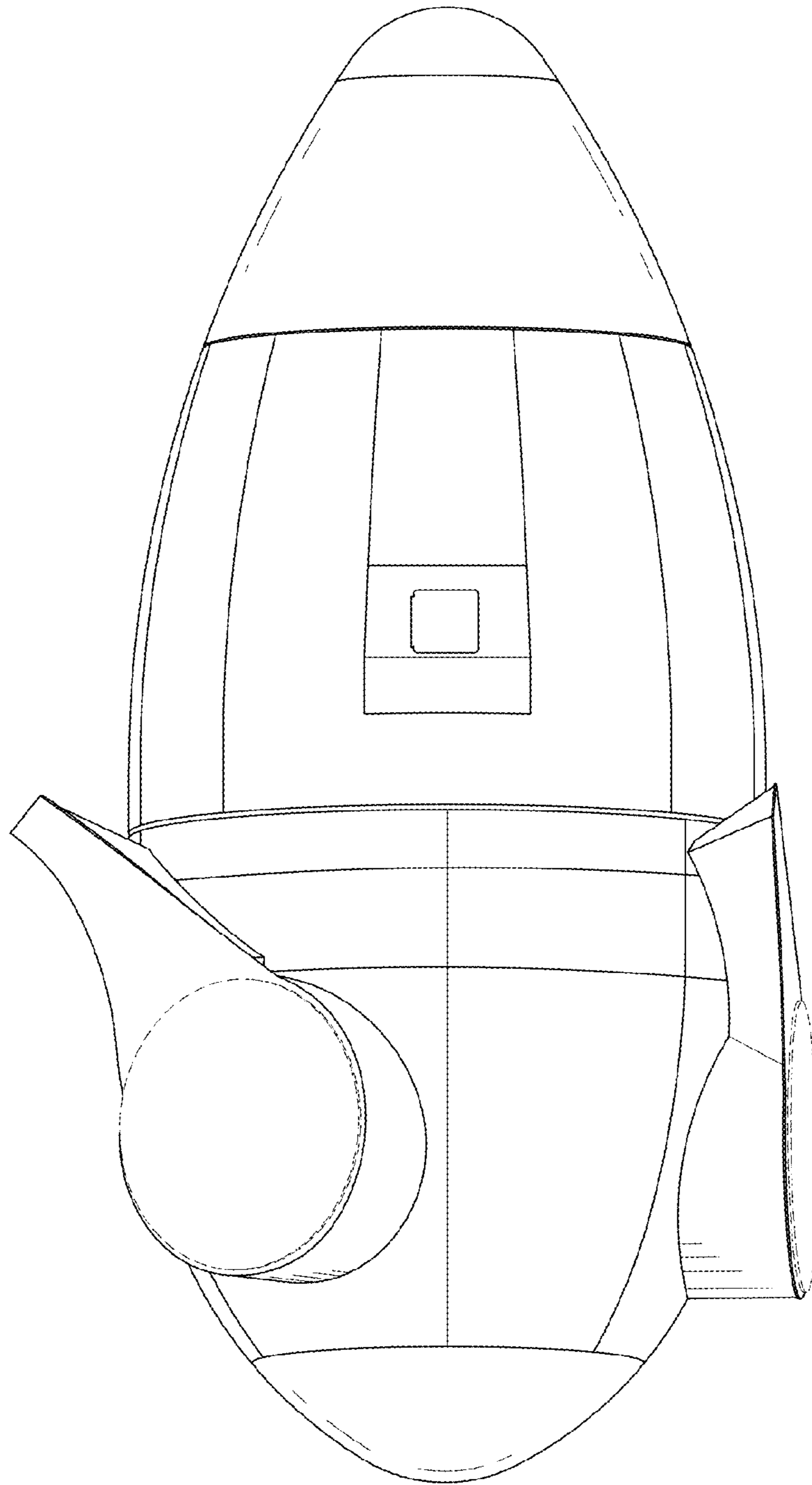

FIG. 4



*FIG. 5*



*FIG. 6*



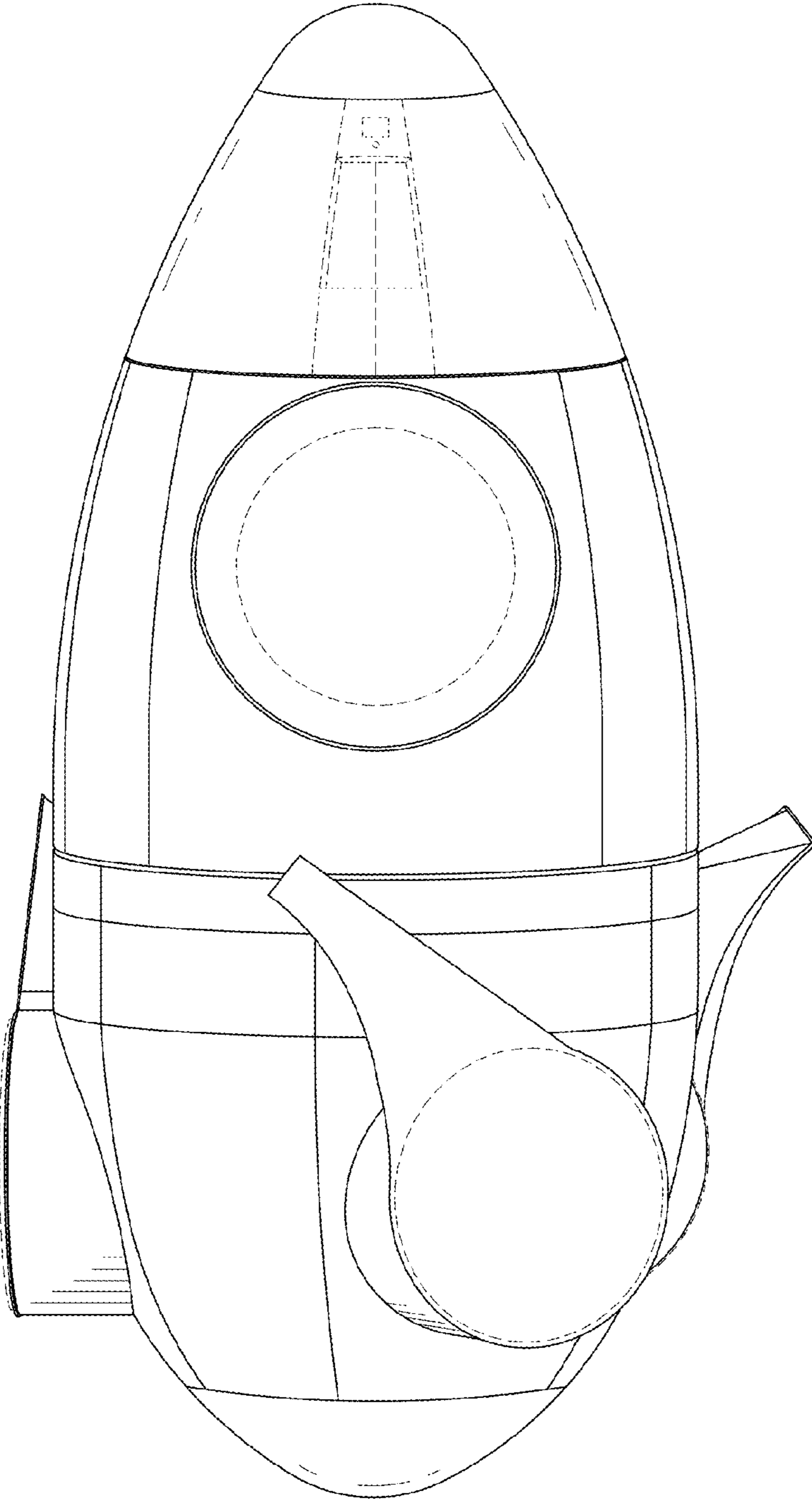

FIG. 7