



US00D727232S

(12) **United States Design Patent**
Frei

(10) **Patent No.:** **US D727,232 S**
(45) **Date of Patent:** **** Apr. 21, 2015**

(54) **WHEEL OR WHEEL COVER**

(71) Applicant: **Daimler AG**, Stuttgart (DE)

(72) Inventor: **Michael Frei**, Sindelfingen (DE)

(73) Assignee: **Daimler AG**, Stuttgart (DE)

(**) Term: **14 Years**

(21) Appl. No.: **29/439,391**

(22) Filed: **Dec. 11, 2012**

(30) **Foreign Application Priority Data**

Jun. 12, 2012 (WO) 078831

(51) **LOC (10) Cl.** **12-16**

(52) **U.S. Cl.**
USPC **D12/209**

(58) **Field of Classification Search**
CPC B60B 7/00; B60B 7/02; B60B 7/04;
B60B 7/01; B60B 7/06; B60B 3/02; B60B
3/04; B60B 3/06; B60B 3/10; B60B 1/00;
B60B 1/08; B60B 1/10; B60B 1/12
USPC D12/204–213
See application file for complete search history.

(56) **References Cited**

U.S. PATENT DOCUMENTS

D476,938 S * 7/2003 Hatori D12/209
D480,674 S * 10/2003 Lecher et al. D12/209
D507,517 S * 7/2005 Kushartanto D12/209

D515,490 S * 2/2006 Pfeiffer D12/209
D548,161 S * 8/2007 Young D12/209
D562,207 S * 2/2008 Pfeiffer
D587,178 S * 2/2009 Pfeiffer D12/209
D593,919 S * 6/2009 Pfeiffer D12/209
D594,396 S * 6/2009 Juergens et al. D12/209
D619,950 S * 7/2010 Antoniadis et al. D12/209
D645,391 S * 9/2011 Weil D12/209
D649,501 S * 11/2011 Platto et al. D12/209
D671,875 S * 12/2012 Camacho et al. D12/209
D686,129 S * 7/2013 Juergens et al. D12/209
D693,284 S * 11/2013 Chen et al. D12/211
D697,003 S * 1/2014 Baum et al. D12/209
D715,715 S * 10/2014 Pollmann D12/209

* cited by examiner

Primary Examiner — Stacia Cadmus

(74) *Attorney, Agent, or Firm* — Crowell & Moring LLP

(57) **CLAIM**

The ornamental design for a wheel or wheel cover, as shown and described.

DESCRIPTION

FIG. 1 is a front view of a wheel or wheel cover according to the design; and,

FIG. 2 is a perspective view thereof.

The broken line showing of the rear of the wheel, the valve stem hole and the bolts holes and center hole in the central hub area is included for the purpose of illustrating environment and forms no part of the claimed design.

1 Claim, 1 Drawing Sheet

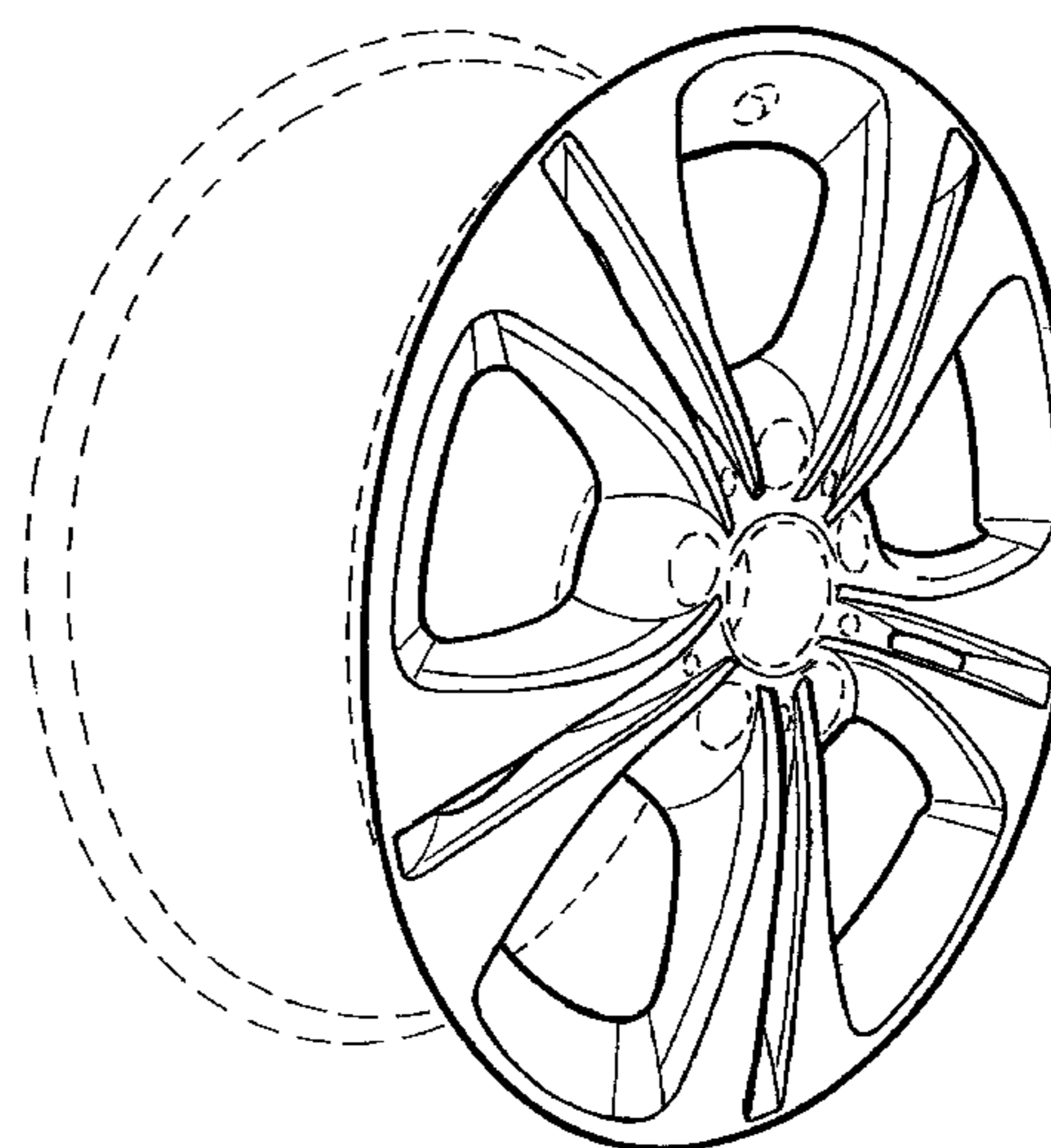
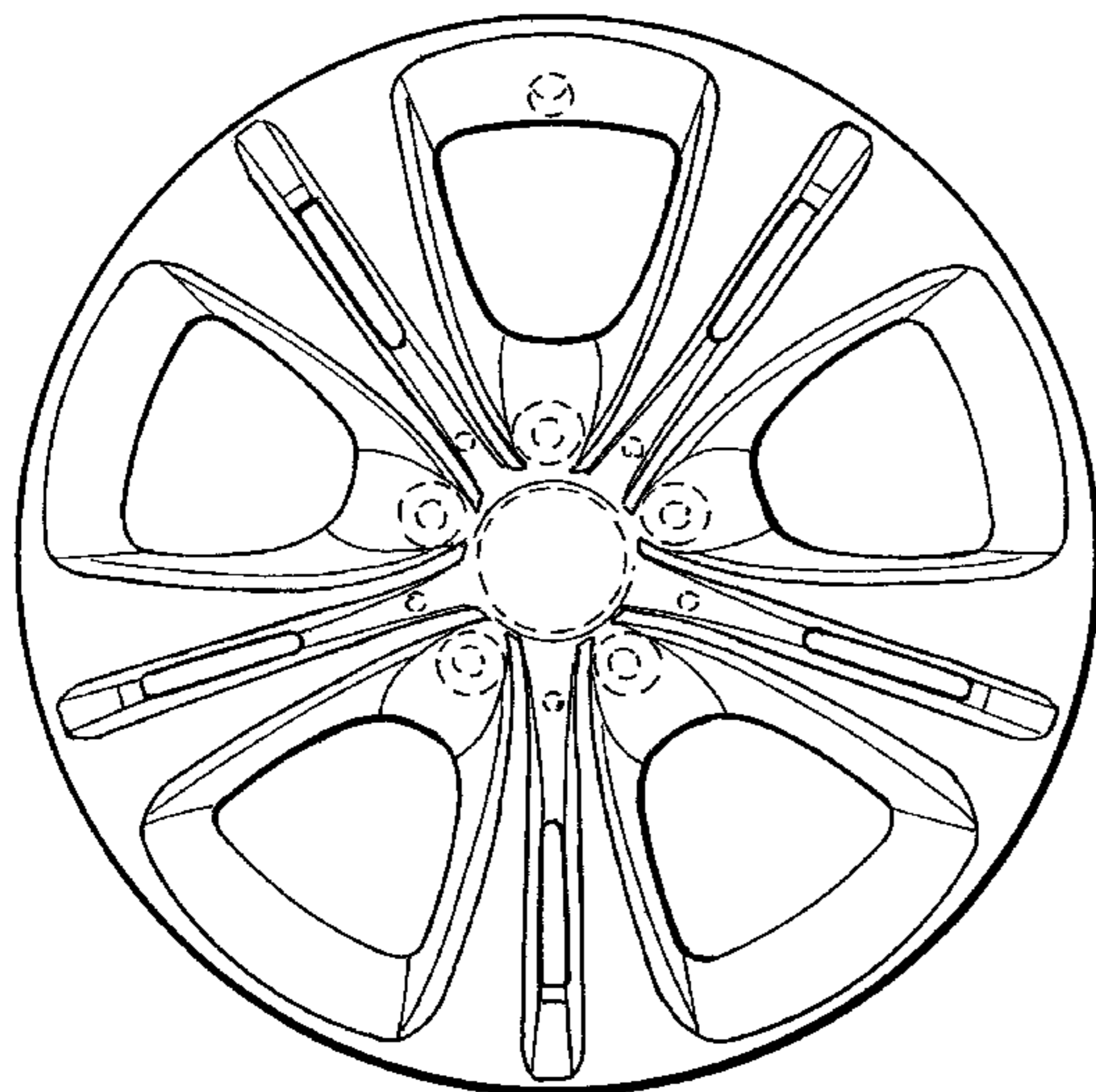

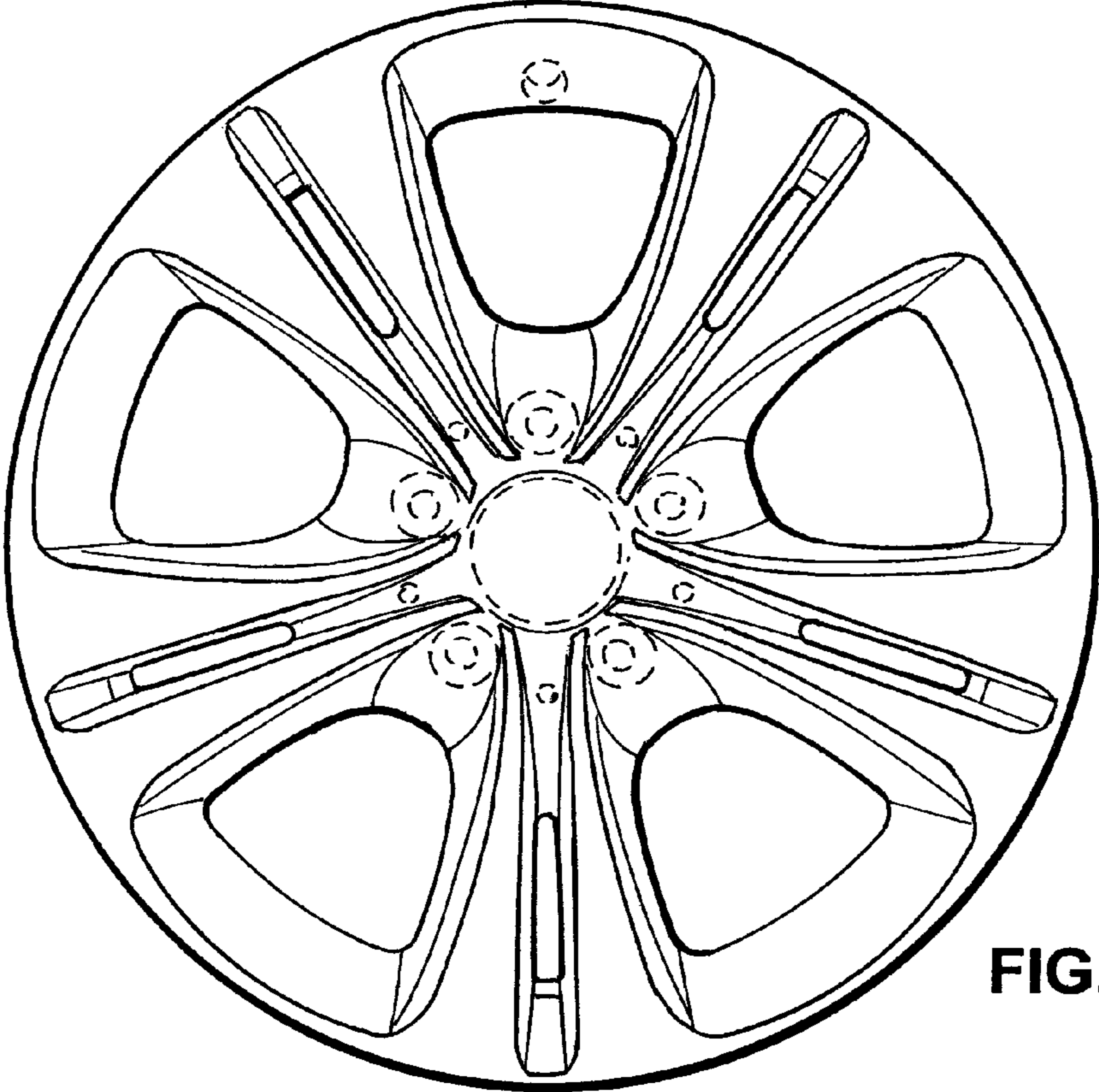

FIG. 1

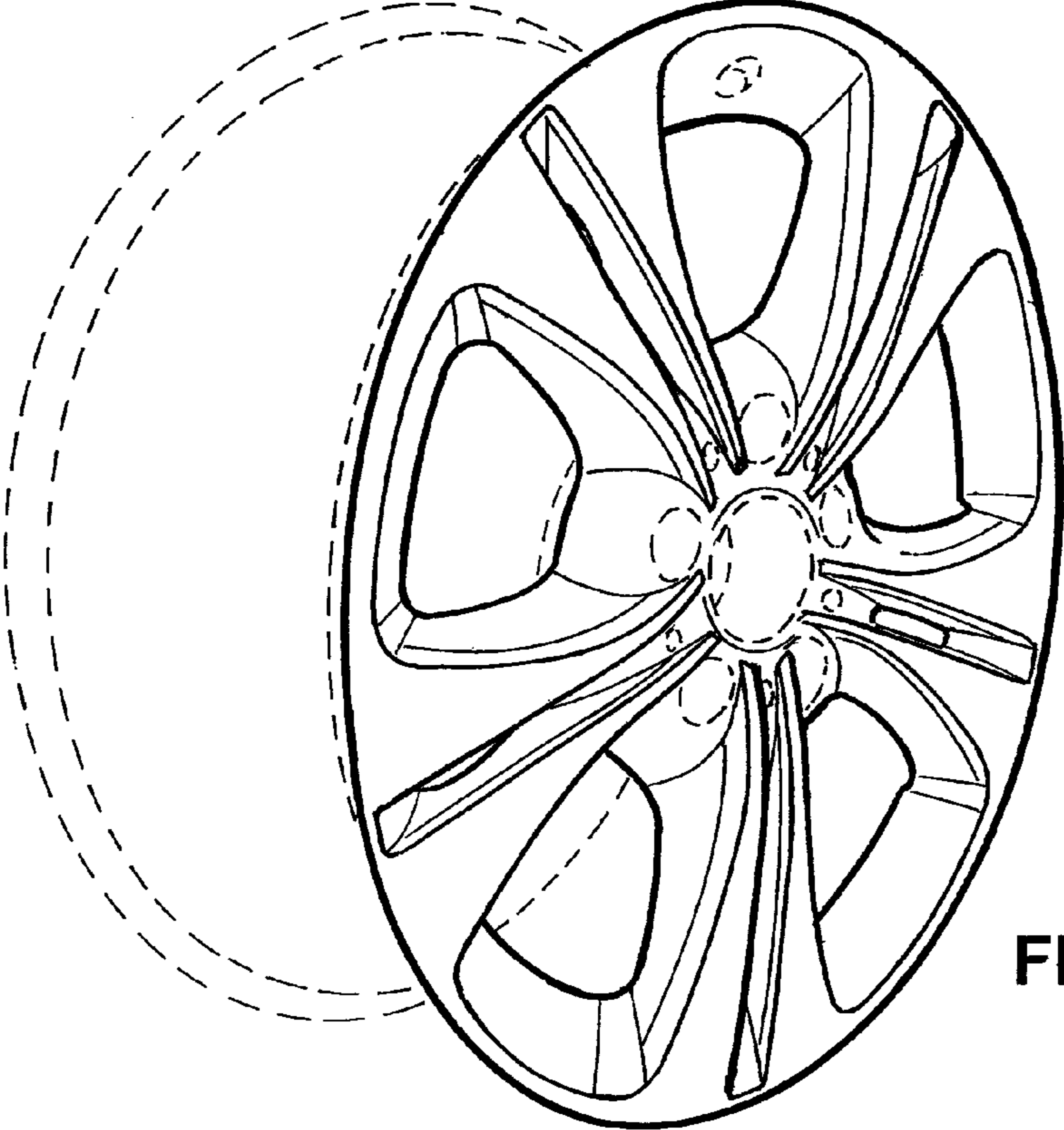

FIG. 2