



US00D727156S

(12) **United States Design Patent**  
**Lavigne et al.**

(10) **Patent No.:** **US D727,156 S**  
(45) **Date of Patent:** **\*\* Apr. 21, 2015**

(54) **PERFUME BOTTLE**  
(71) Applicant: **River Light V, L.P.**, New York, NY (US)  
(72) Inventors: **Chad Lavigne**, New York, NY (US);  
**Tory Burch**, New York, NY (US)  
(73) Assignee: **River Light V, L.P.**, New York, NY (US)  
(\*\*) Term: **14 Years**

(21) Appl. No.: **29/471,312**  
(22) Filed: **Oct. 30, 2013**  
(51) **LOC (10) Cl.** ..... **09-01**  
(52) **U.S. Cl.**  
USPC ..... **D9/516; D9/560**  
(58) **Field of Classification Search**  
CPC ..... B65D 1/00; B65D 1/02; B65D 1/40;  
B65D 69/00; B65D 79/00; B65D 81/00;  
B65D 83/00; B65D 83/14; B65D 83/38;  
B65D 90/02; B65D 2501/0009; B65D  
2501/0081  
USPC ..... D9/434, 516, 544-546, 559-560,  
D9/572-575, 682, 686-687, 693-694;  
D7/300, 300.1, 598; D28/91.1;  
215/379, 382; 220/660, 662, 669, 675  
See application file for complete search history.

(56) **References Cited**

**U.S. PATENT DOCUMENTS**

D90,558 S 8/1933 Tricard  
D214,877 S \* 8/1969 Biallo et al. .... D9/529  
D388,712 S \* 1/1998 Lyngdal et al. .... D9/563  
D420,596 S 2/2000 Maddy  
D494,476 S \* 8/2004 Cwynar-Laska et al. .... D9/560

D519,844 S 5/2006 Mansau  
D526,206 S \* 8/2006 Varlet ..... D9/560  
D542,144 S 5/2007 Herrmann  
D542,670 S \* 5/2007 Herrmann ..... D9/560  
D555,002 S \* 11/2007 Lloyd et al. .... D9/544  
D577,600 S 9/2008 Kim et al.  
D604,174 S \* 11/2009 Rica ..... D9/560  
D678,074 S 3/2013 DeFrance  
D694,120 S \* 11/2013 Baussan ..... D9/652

**FOREIGN PATENT DOCUMENTS**

WO DM/075297 \* 2/2011  
WO DM/080174 \* 12/2012  
WO DM/083111 \* 3/2014

\* cited by examiner

*Primary Examiner* — Terry Wallace

*Assistant Examiner* — Dana L Meyrow

(74) *Attorney, Agent, or Firm* — Kilpatrick Townsend & Stockton LLP

(57) **CLAIM**

The ornamental design for a perfume bottle, as shown and described.

**DESCRIPTION**

FIG. 1 is a perspective view of a perfume bottle.  
FIG. 2 is a front view of the perfume bottle of FIG. 1.  
FIG. 3 is a right side view of the perfume bottle of FIG. 1, the left side view being a mirror image of the right side view; and, FIG. 4 is a top view of the perfume bottle of FIG. 1.  
The broken lines form no part of the claimed design.

**1 Claim, 4 Drawing Sheets**

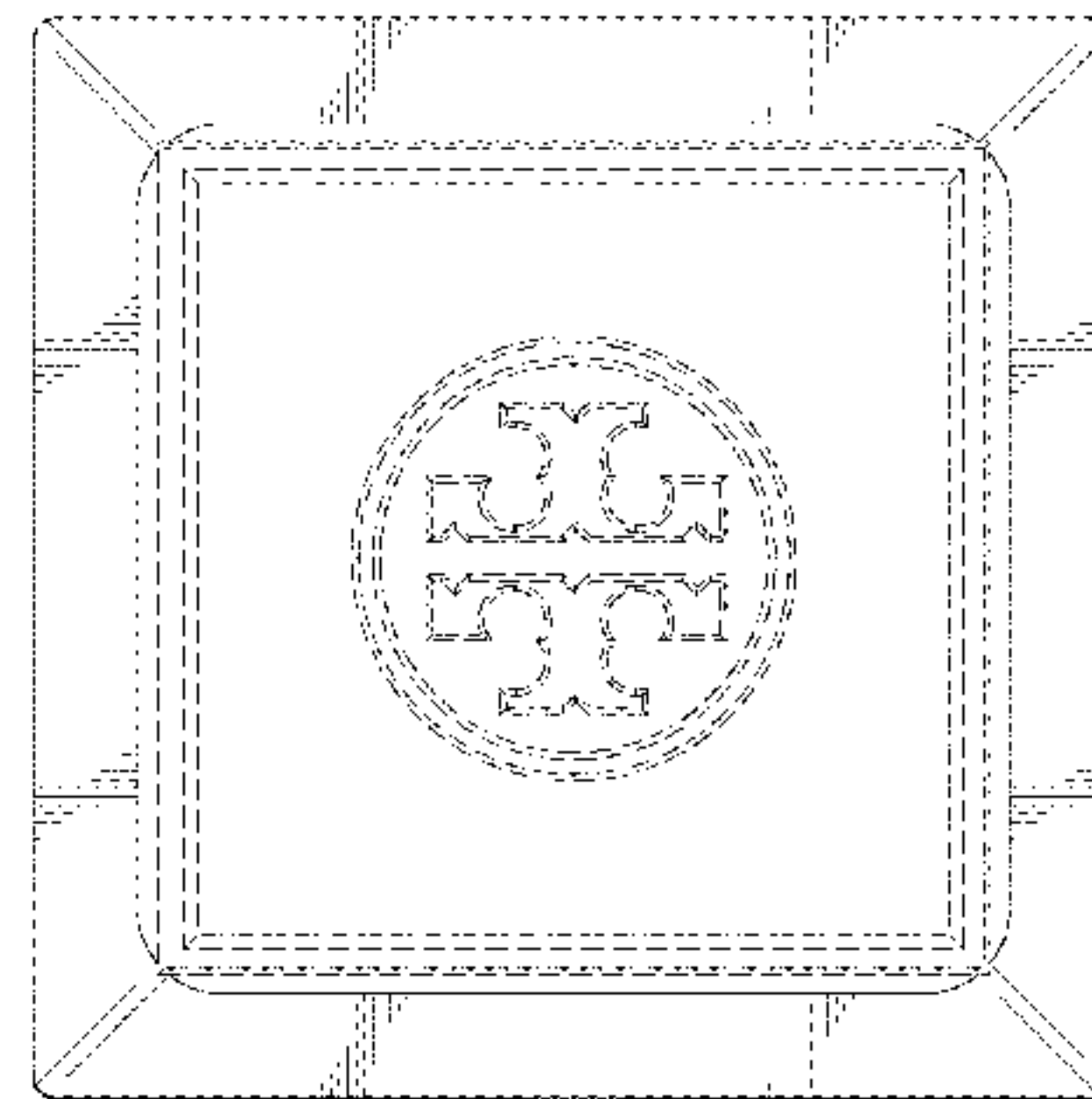
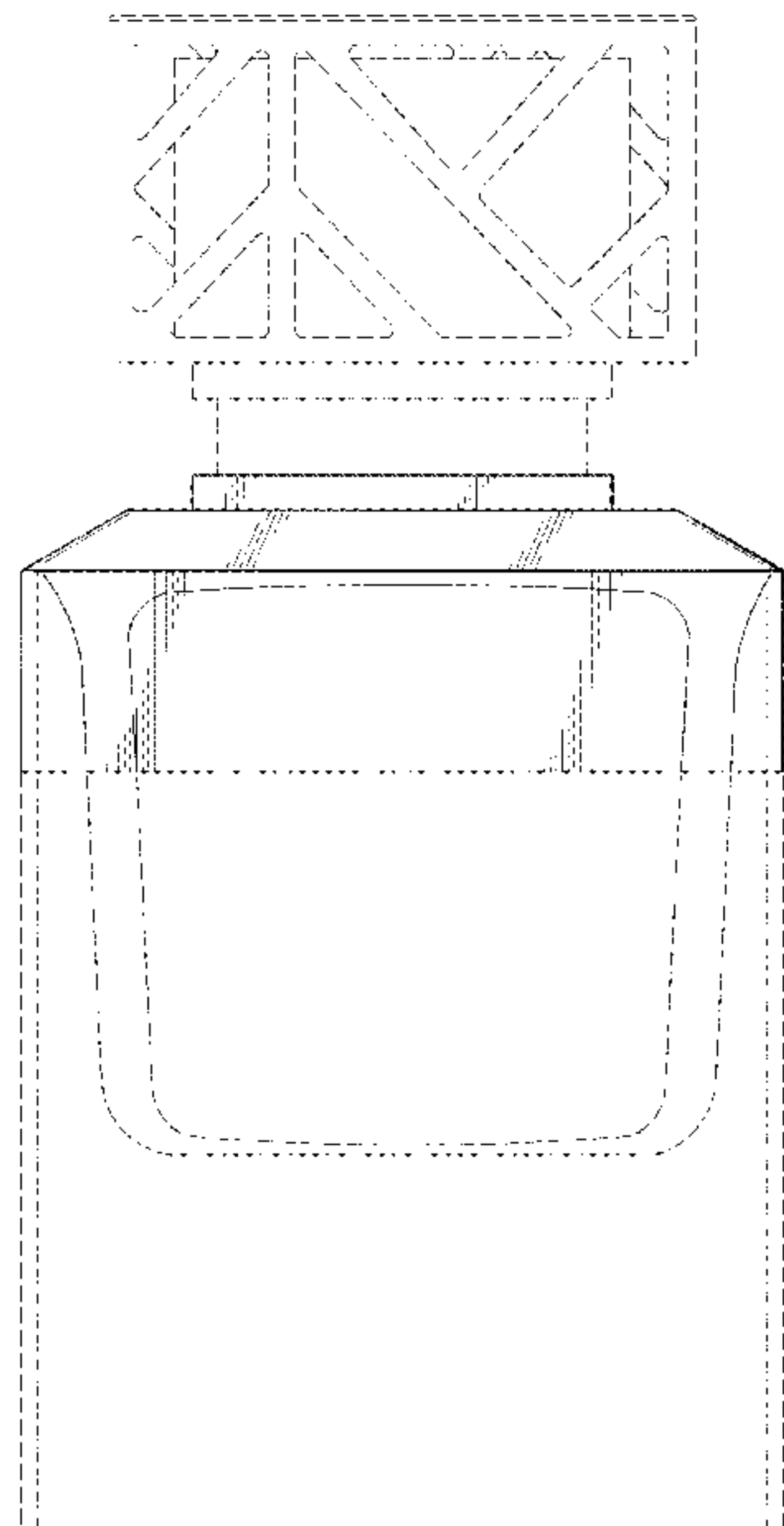

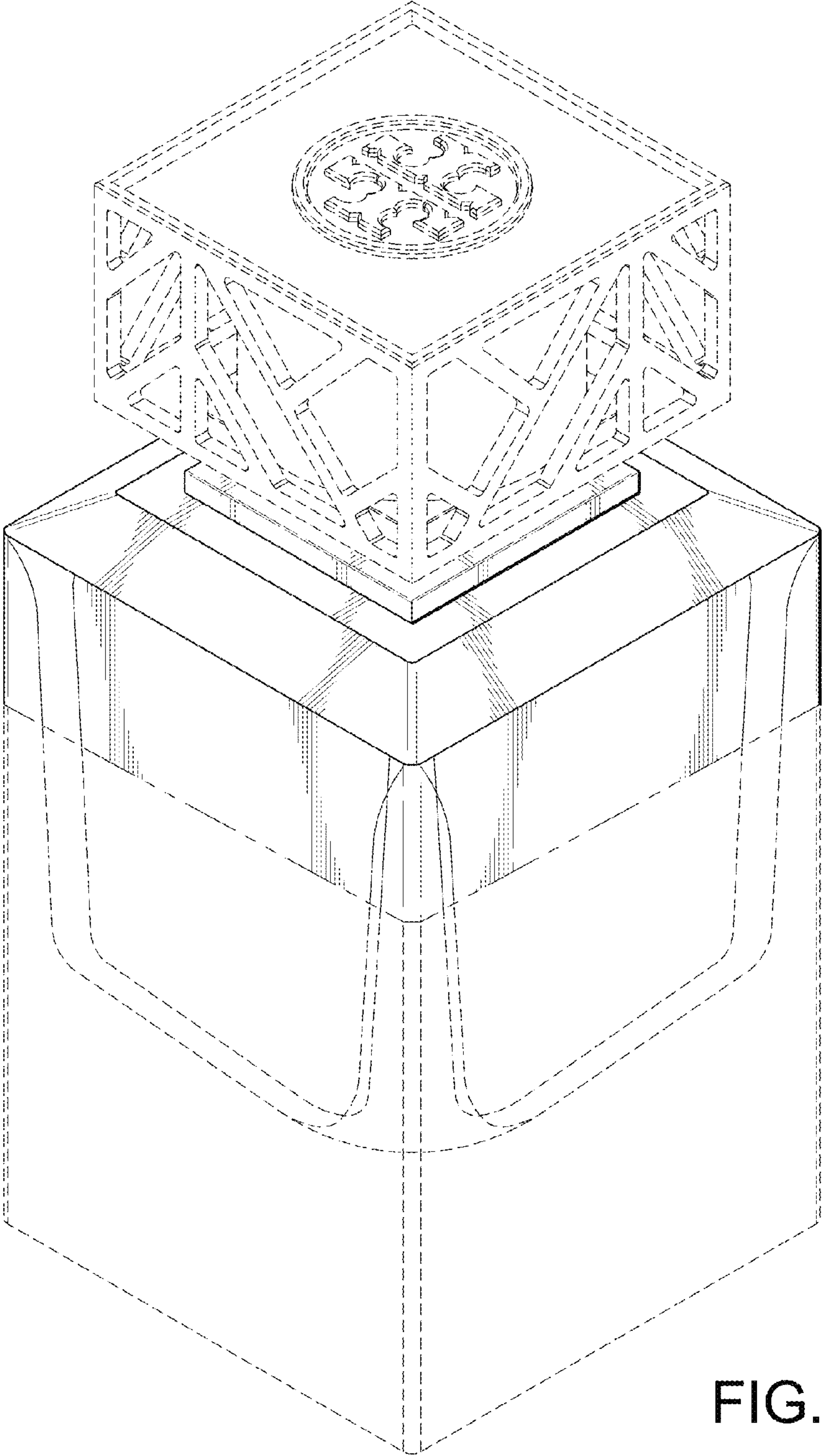

FIG. 1

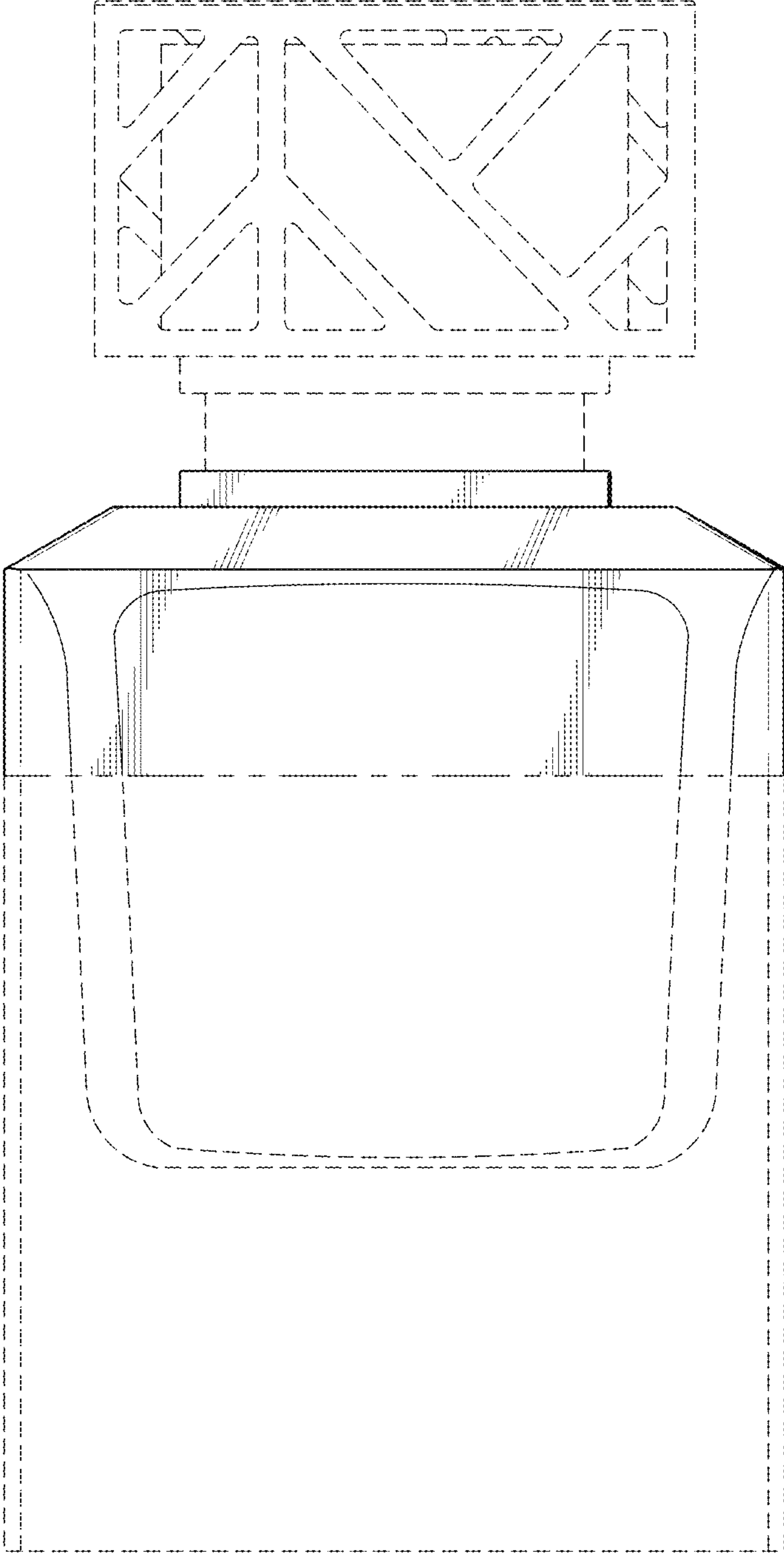

FIG. 2

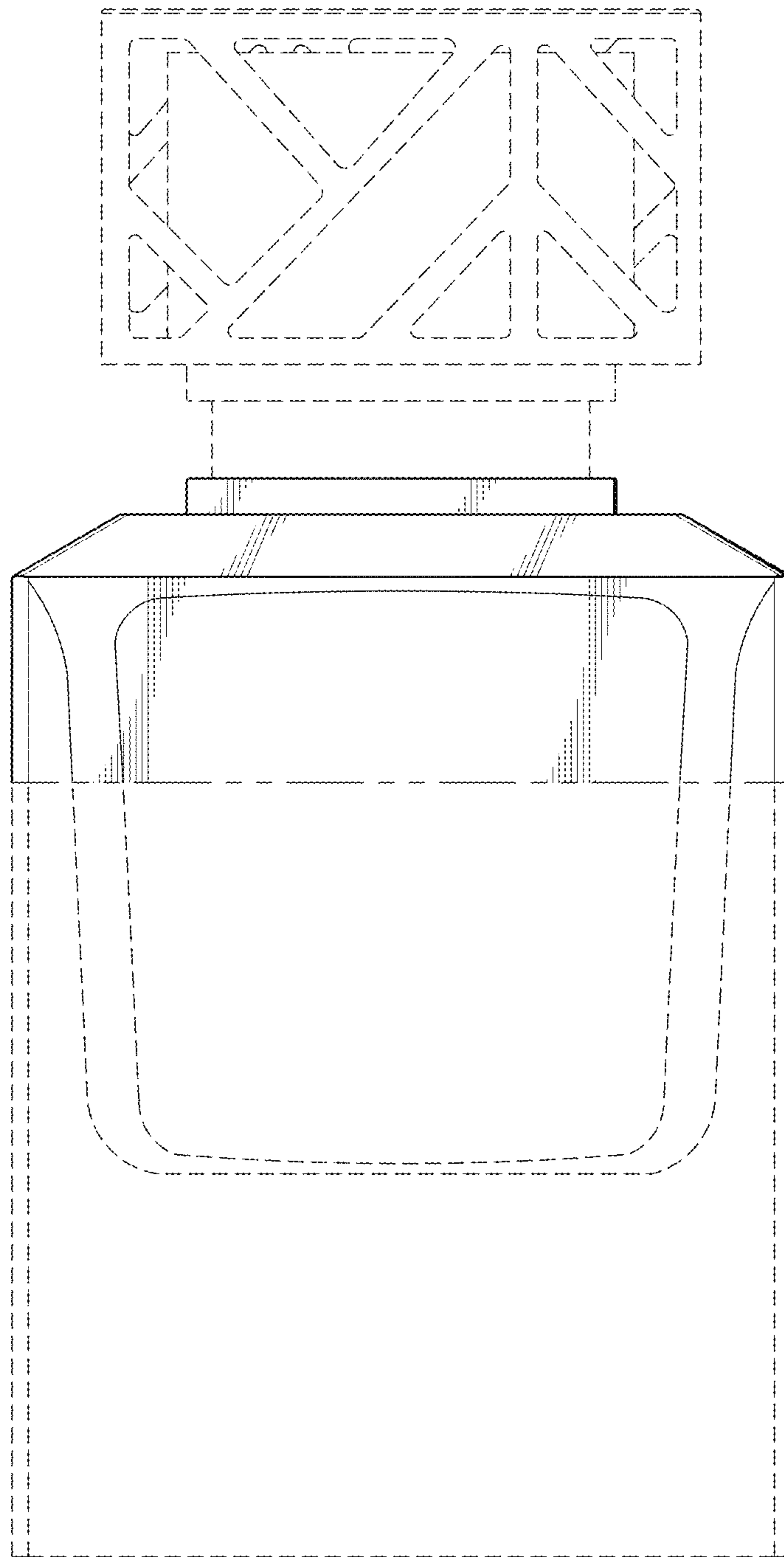

FIG. 3

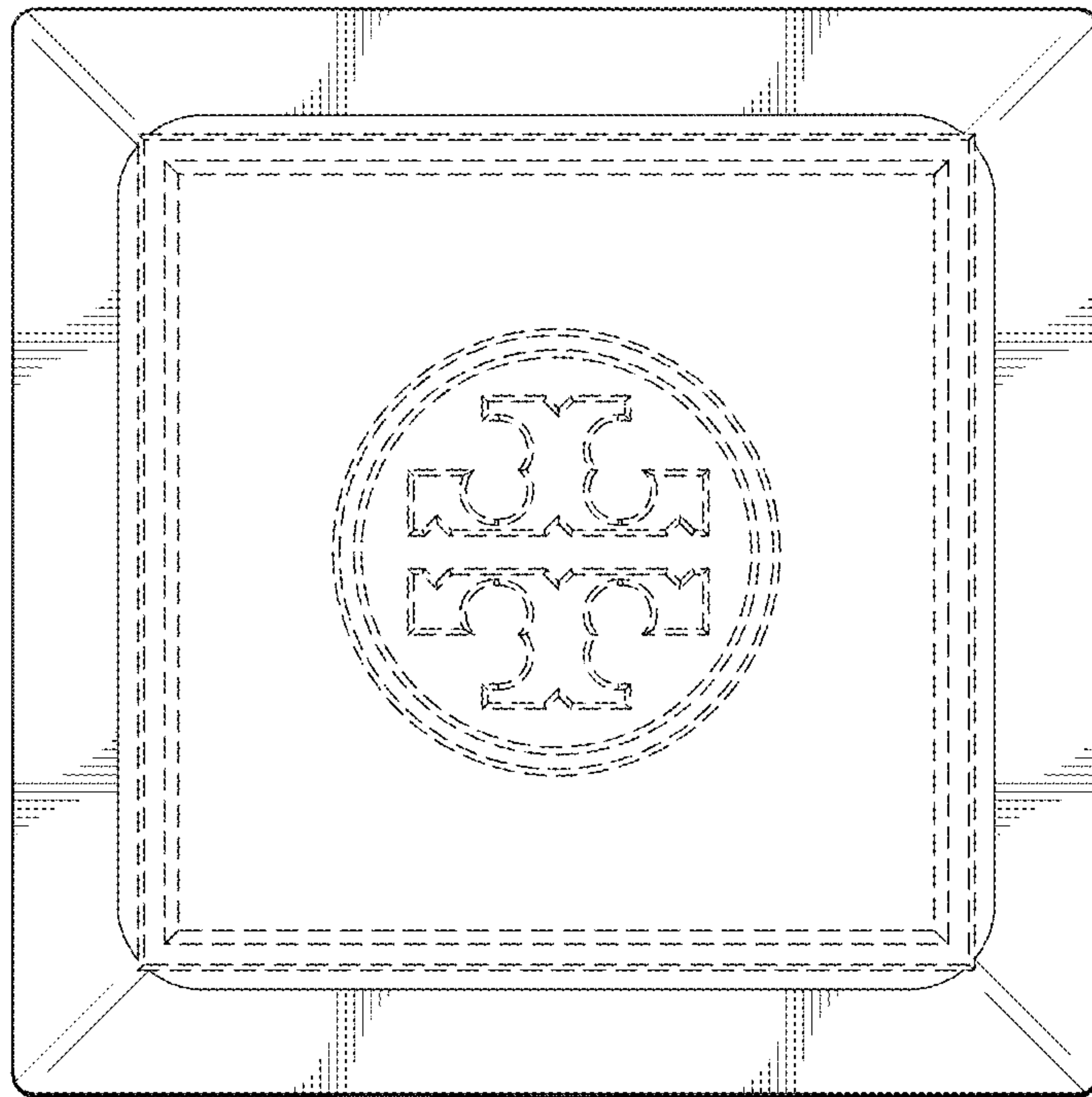

FIG. 4