



US00D726879S

(12) **United States Design Patent**  
**Tanaka**

(10) **Patent No.:** **US D726,879 S**  
(45) **Date of Patent:** **\*\* Apr. 14, 2015**

(54) **ELECTRIC FLUID PRESSURE ACTUATOR**

(71) Applicant: **Kayaba Industry Co., Ltd.**, Tokyo (JP)

(72) Inventor: **Daisuke Tanaka**, Gifu (JP)

(73) Assignee: **Kayaba Industry Co., Ltd.**, Tokyo (JP)

(\*\*) Term: **14 Years**

(21) Appl. No.: **29/462,212**

(22) Filed: **Jul. 31, 2013**

(30) **Foreign Application Priority Data**

Jan. 31, 2013 (JP) ..... 2013-1914

(51) **LOC (10) Cl.** ..... **23-01**

(52) **U.S. Cl.**  
USPC ..... **D23/235**

(58) **Field of Classification Search**

CPC . F16H 25/2252; F16H 25/20; F16D 2125/40;  
F16D 2121/24; F16D 65/18; B41J 2/14201;  
F15B 15/02

USPC ..... D23/235; D15/143, 149, 199, 148;  
D13/107, 110; 74/89.23, 25, 413;  
310/78; D10/85; 137/601.13, 601.14,  
137/601.15, 866, 869, 870, 871, 885, 886

See application file for complete search history.

(56) **References Cited**

**U.S. PATENT DOCUMENTS**

D379,468 S \* 5/1997 Nagai et al. .... D15/199  
D380,221 S \* 6/1997 Nagai et al. .... D15/199  
D412,917 S \* 8/1999 Nagai et al. .... D15/199  
D412,918 S \* 8/1999 Nagai et al. .... D15/199  
D413,129 S \* 8/1999 Nagai et al. .... D15/199

(Continued)

*Primary Examiner* — Cynthia Ramirez

*Assistant Examiner* — Gino Colan

(74) *Attorney, Agent, or Firm* — Lowe Hauptman & Ham, LLP

(57) **CLAIM**

The ornamental design for an electric fluid pressure actuator, as shown and described.

**DESCRIPTION**

FIG. 1 is a front view of the electric fluid pressure actuator. FIG. 2 is a left side view of the electric fluid pressure actuator. FIG. 3 is a right side view of the electric fluid pressure actuator.

FIG. 4 is a rear view of the electric fluid pressure actuator. FIG. 5 is a top plan view of the electric fluid pressure actuator. FIG. 6 is a bottom plan view of the electric fluid pressure actuator.

FIG. 7 is a right-top perspective view of the electric fluid pressure actuator.

FIG. 8 is a left-top perspective view of the electric fluid pressure actuator.

FIG. 9 is a right-bottom perspective view of the electric fluid pressure actuator; and,

FIG. 10 is a left-bottom perspective view of the electric fluid pressure actuator.

The article to which a design is applied is an electric fluid pressure actuator as shown in the drawings. The one end of the electric fluid pressure actuator is attached to the first member. The another end of the electric fluid pressure actuator is attached to the second member. The electric fluid pressure actuator drives the first member or the second member. The electric fluid pressure actuator includes: an electric motor, a fluid pressure pump which is driven by the electric motor, a tank which holds actuating fluid, and a fluid pressure cylinder having a rod which is expanded and contracted by the actuating fluid discharged from the fluid pressure pump. The fluid pressure pump and the tank are provided integrally in the fluid pressure cylinder.

The broken line shown in the figures are included for the purpose of illustrating elements of the electric fluid pressure actuator and form no part of the claimed design.

**1 Claim, 10 Drawing Sheets**



(56)

References Cited

U.S. PATENT DOCUMENTS

|                |         |                    |       |          |                   |         |                  |       |          |
|----------------|---------|--------------------|-------|----------|-------------------|---------|------------------|-------|----------|
| D502,477 S *   | 3/2005  | Beadle et al.      | ..... | D15/148  | D636,799 S *      | 4/2011  | Fukano et al.    | ..... | D15/143  |
| D509,520 S *   | 9/2005  | Klinke et al.      | ..... | D15/143  | D638,730 S *      | 5/2011  | Ishibashi et al. | ..... | D10/85   |
| D522,028 S *   | 5/2006  | Beadle et al.      | ..... | D15/148  | D650,401 S *      | 12/2011 | Fukano et al.    | ..... | D15/143  |
| D522,546 S *   | 6/2006  | Beadle et al.      | ..... | D15/148  | D656,975 S *      | 4/2012  | Tseng            | ..... | D15/143  |
| D522,547 S *   | 6/2006  | Beadle et al.      | ..... | D15/148  | D657,399 S *      | 4/2012  | Nemoto           | ..... | D15/28   |
| D523,880 S *   | 6/2006  | Christensen et al. | ..... | D15/143  | D660,334 S *      | 5/2012  | Takeuchi et al.  | ..... | D15/143  |
| D524,335 S *   | 7/2006  | Klinke et al.      | ..... | D15/143  | D665,433 S *      | 8/2012  | Beam et al.      | ..... | D15/143  |
| D595,753 S *   | 7/2009  | Tseng              | ..... | D15/143  | D681,085 S *      | 4/2013  | Mangold          | ..... | D15/143  |
| D596,653 S *   | 7/2009  | Fukano et al.      | ..... | D15/143  | D682,901 S *      | 5/2013  | Peschel          | ..... | D15/143  |
| 7,562,594 B2 * | 7/2009  | Nagai et al.       | ..... | 74/89.23 | D685,014 S *      | 6/2013  | Mangold          | ..... | D15/143  |
| D607,912 S *   | 1/2010  | Medici             | ..... | D15/149  | D685,403 S *      | 7/2013  | Mangold          | ..... | D15/143  |
| D612,407 S *   | 3/2010  | Hagleitner         | ..... | D15/143  | D686,257 S *      | 7/2013  | Wu               | ..... | D15/143  |
| D621,860 S *   | 8/2010  | Fukano et al.      | ..... | D15/143  | D686,648 S *      | 7/2013  | Wu               | ..... | D15/143  |
| D624,098 S *   | 9/2010  | Fukano et al.      | ..... | D15/143  | D695,798 S *      | 12/2013 | Wu               | ..... | D15/143  |
| D624,101 S *   | 9/2010  | Tseng              | ..... | D15/143  | D704,238 S *      | 5/2014  | Fukano et al.    | ..... | D15/143  |
| D624,570 S *   | 9/2010  | Fukano et al.      | ..... | D15/143  | 2006/0081078 A1 * | 4/2006  | Nagai et al.     | ..... | 74/89.23 |
| D625,745 S *   | 10/2010 | Chiang et al.      | ..... | D15/143  | 2008/0048514 A1 * | 2/2008  | Hoffmann et al.  | ..... | 310/78   |
| D635,600 S *   | 4/2011  | Wu                 | ..... | D15/143  | 2008/0184828 A1 * | 8/2008  | Chen et al.      | ..... | 74/25    |
|                |         |                    |       |          | 2009/0314111 A1 * | 12/2009 | Schunke          | ..... | 74/89.32 |
|                |         |                    |       |          | 2011/0232403 A1 * | 9/2011  | Yu et al.        | ..... | 74/413   |

\* cited by examiner

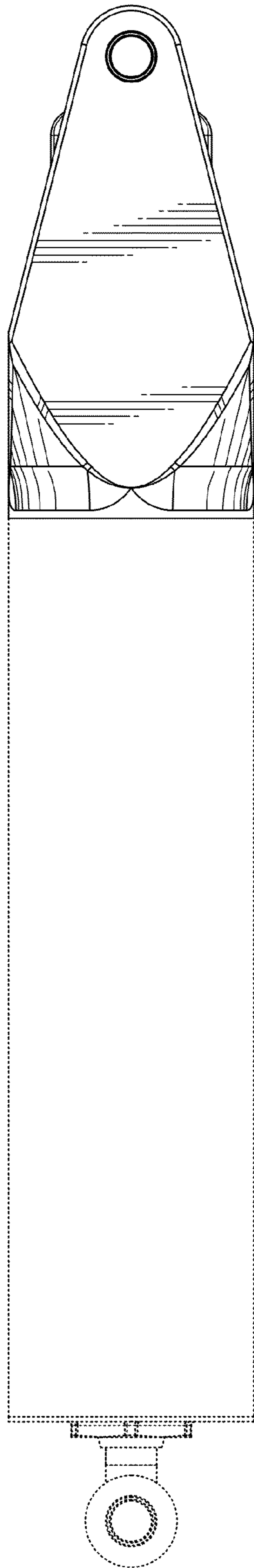
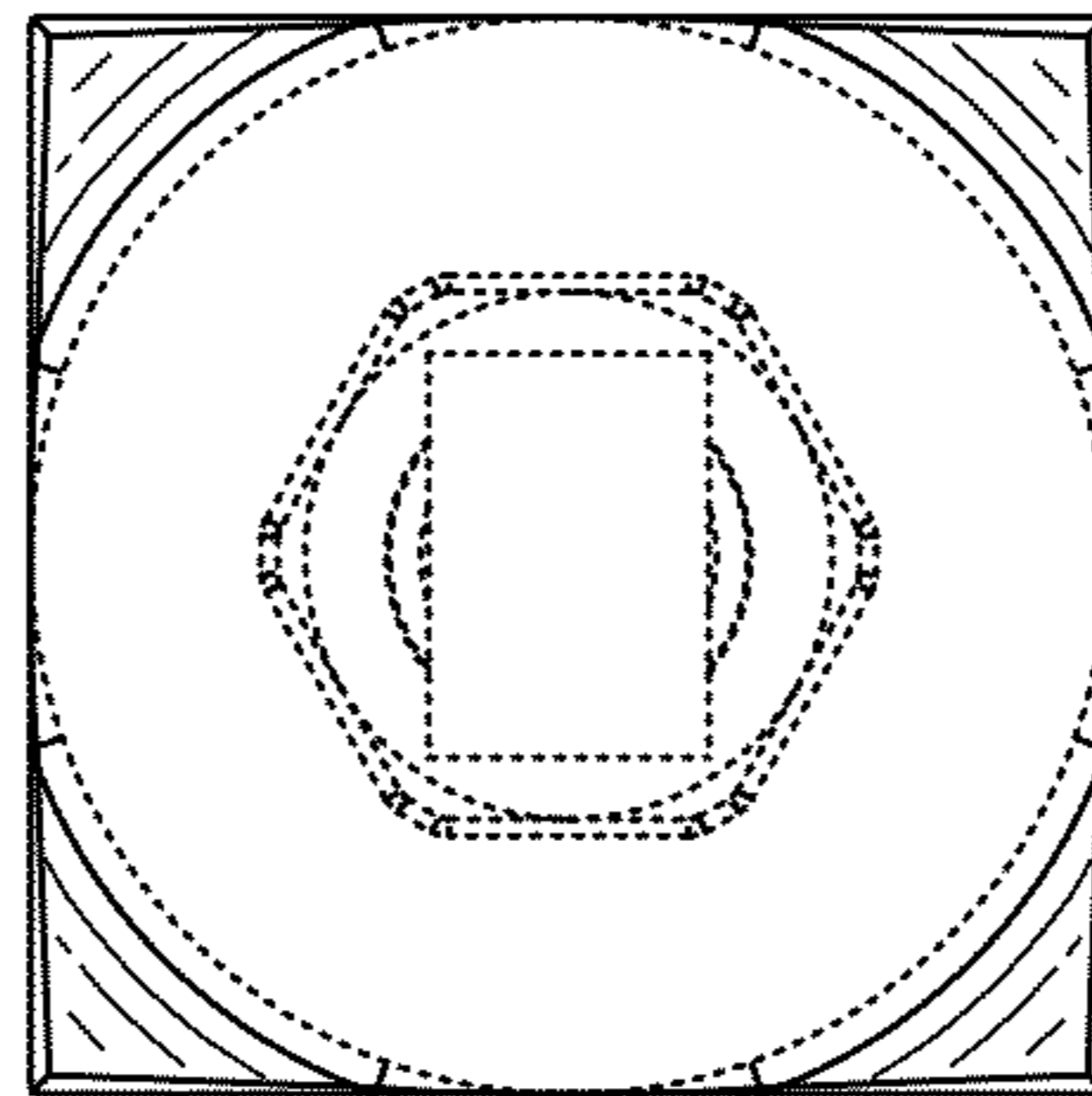
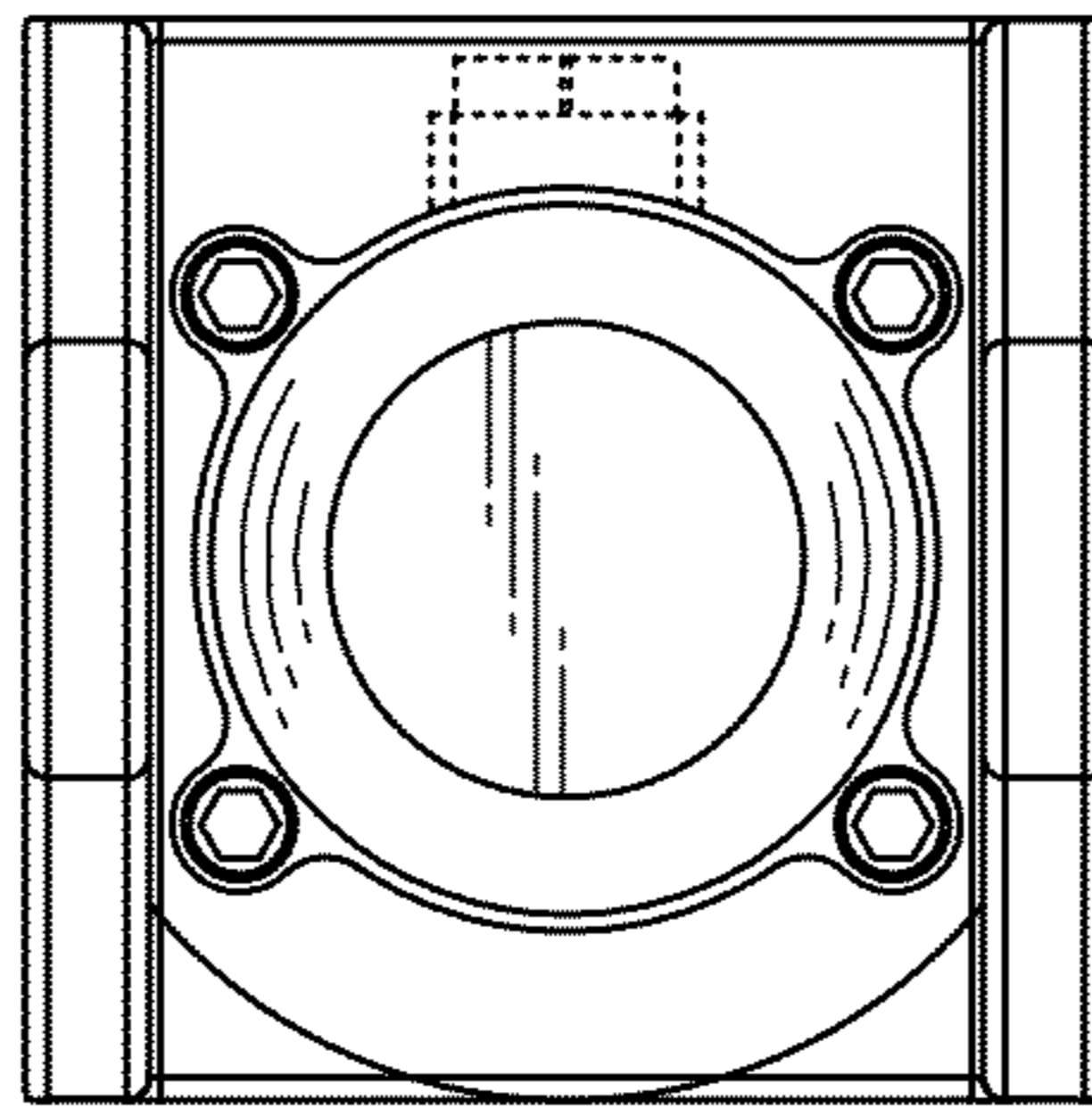

FIG. 1



*FIG. 2*



*FIG. 3*

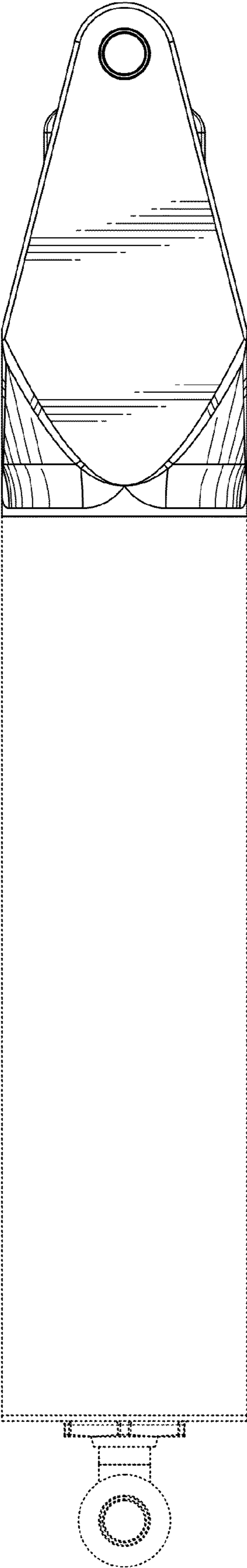

FIG. 4

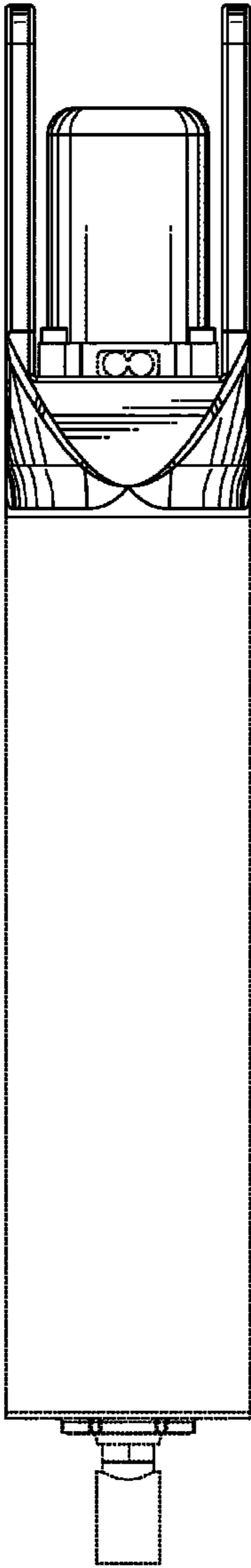

FIG. 5

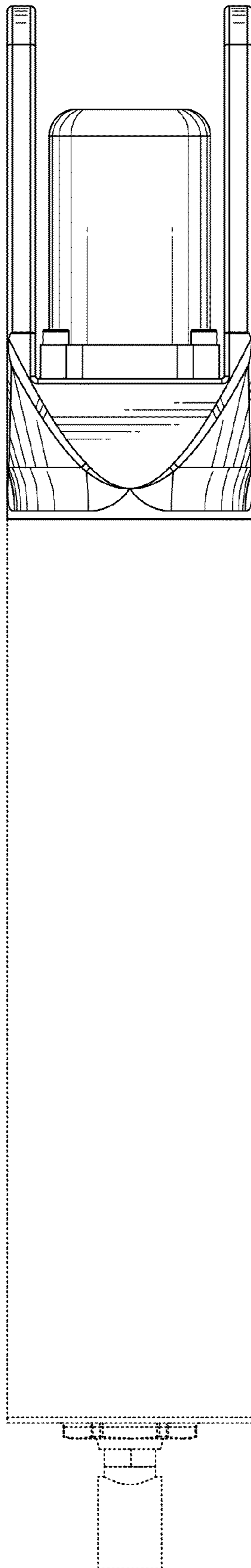
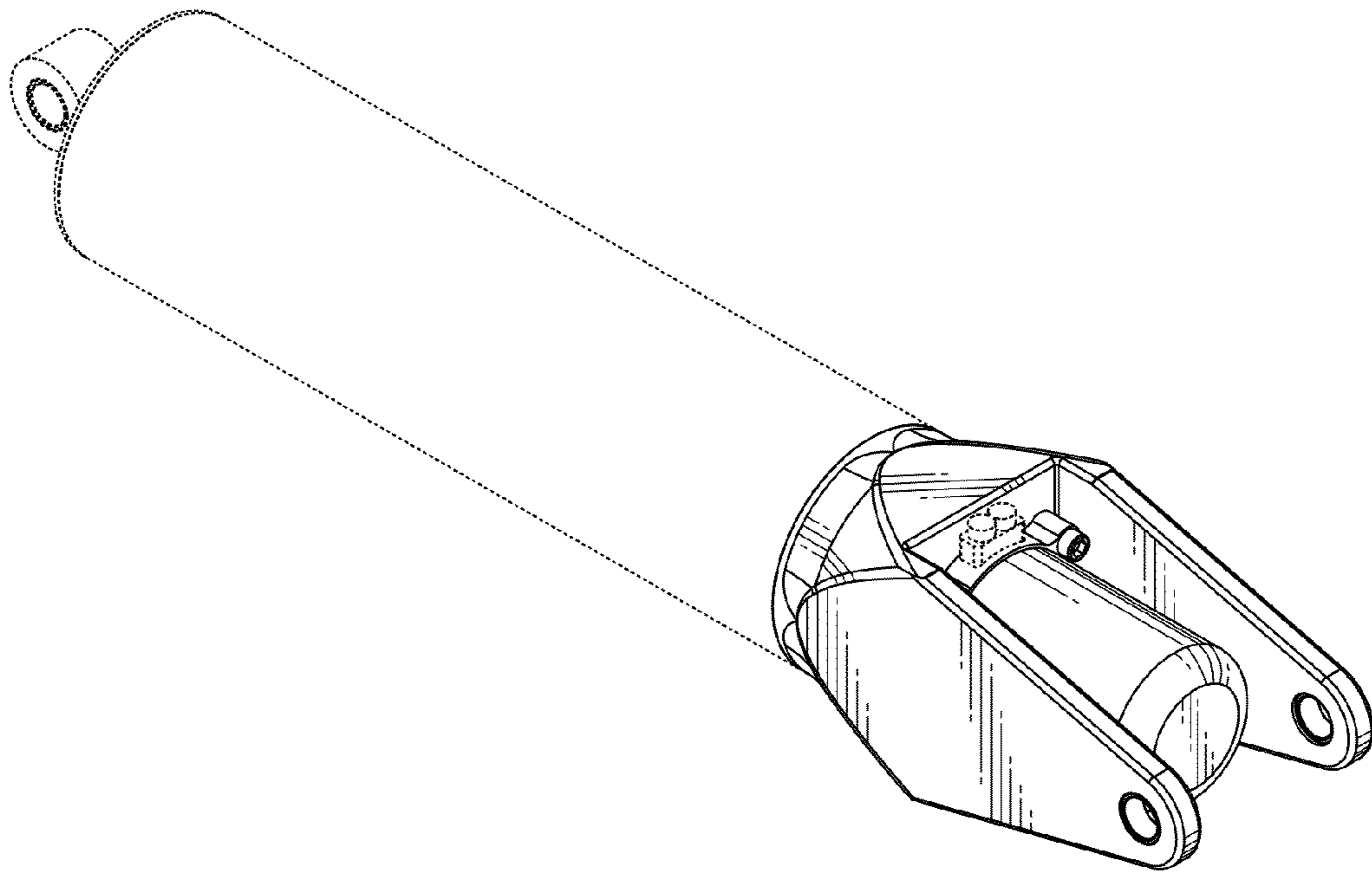
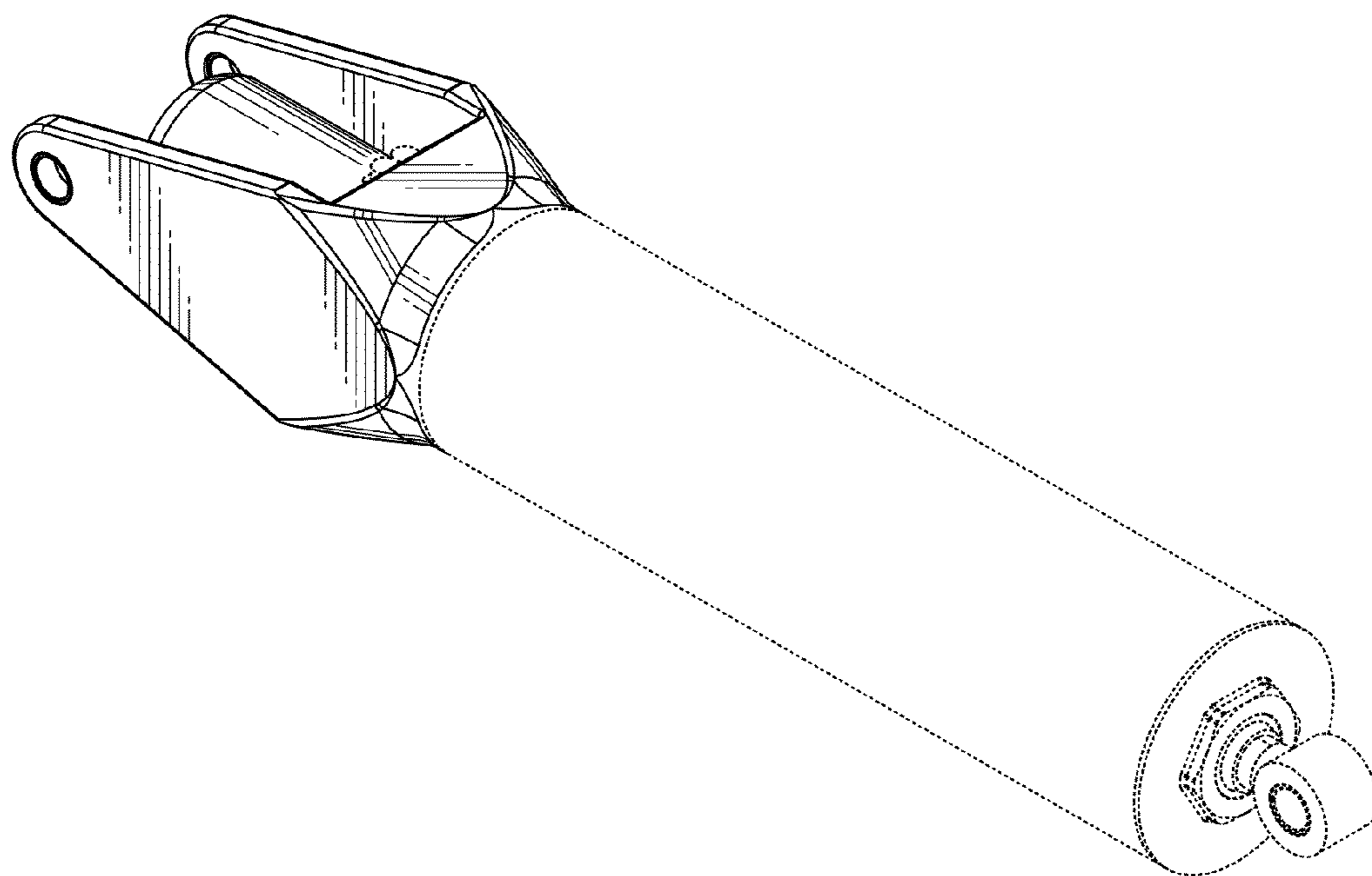

FIG. 6

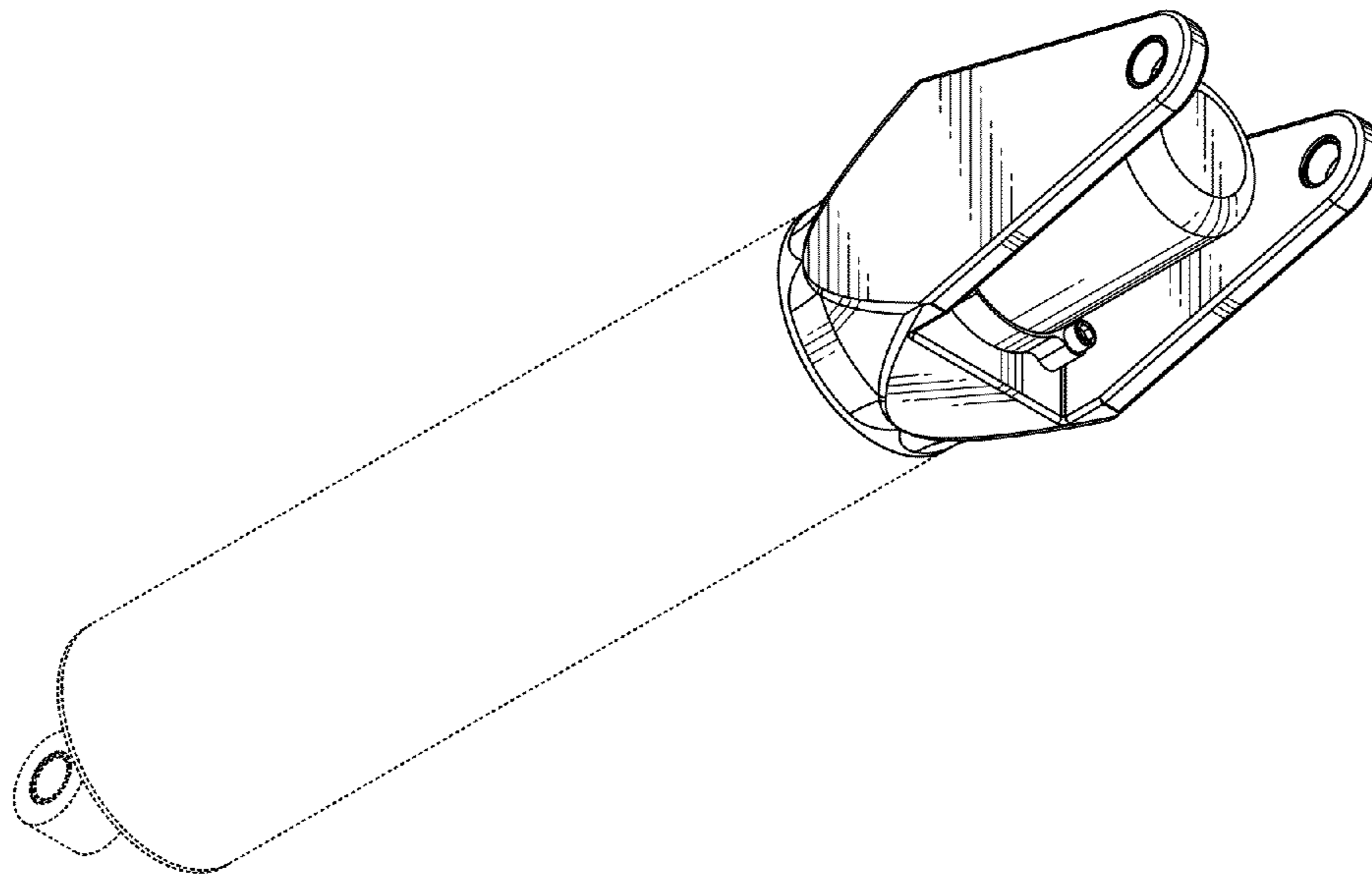



*FIG. 7*



*FIG. 8*



*FIG. 9*

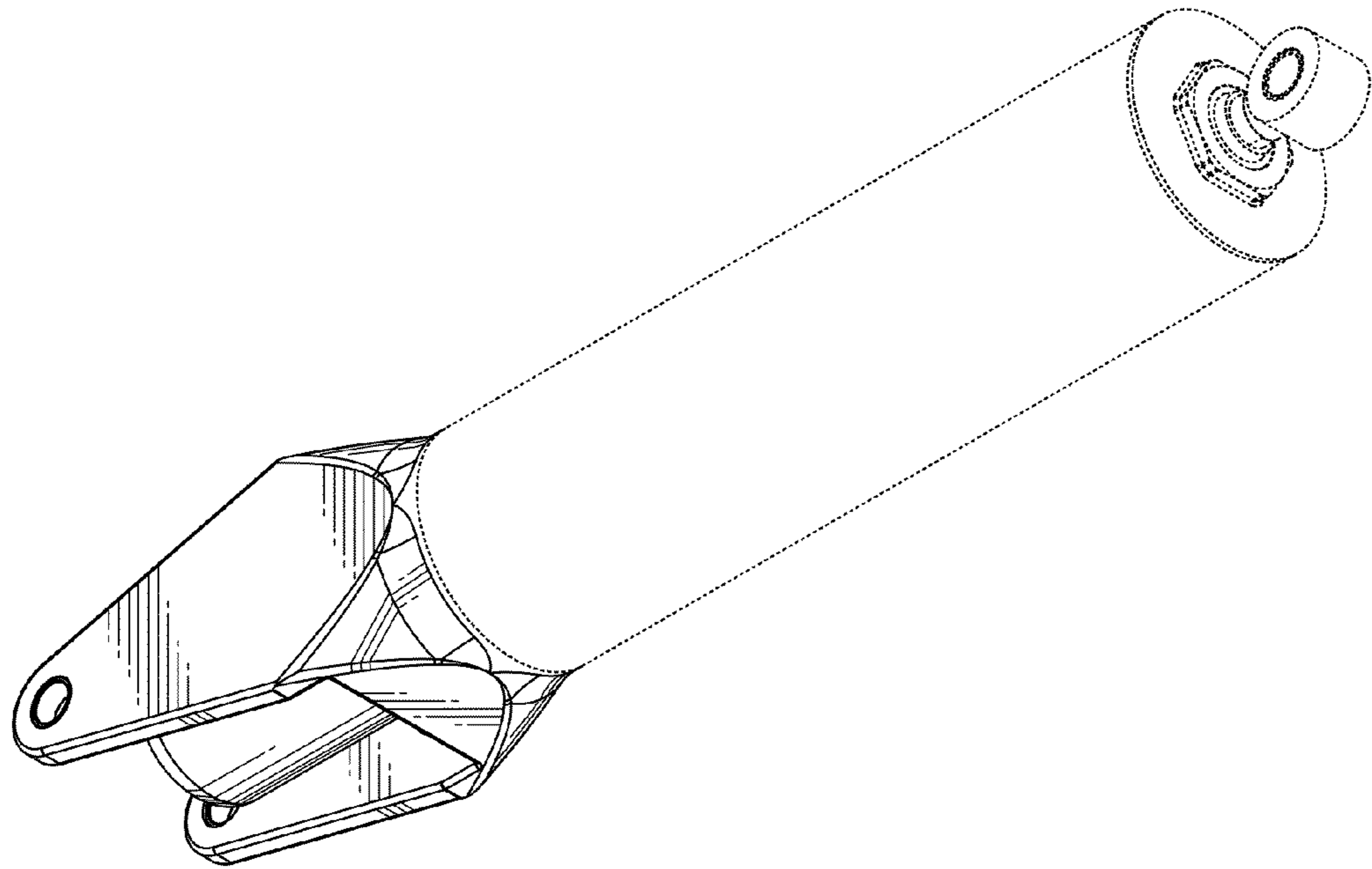

*FIG. 10*