



US00D726870S

(12) **United States Design Patent**
Ruprecht

(10) **Patent No.:** **US D726,870 S**

(45) **Date of Patent:** **** Apr. 14, 2015**

(54) **LIQUID FILTER HOUSING**

(71) Applicant: **Atlas Air & Water, Inc.**, Lakeland, MN
(US)

(72) Inventor: **John Ruprecht**, Lakeland, MN (US)

(73) Assignee: **Rapid Pure Inc**, Lakeland, MN (US)

(**) Term: **14 Years**

(21) Appl. No.: **29/465,624**

(22) Filed: **Aug. 29, 2013**

(51) **LOC (10) Cl.** **23-01**

(52) **U.S. Cl.**
USPC **D23/209**

(58) **Field of Classification Search**

USPC D23/207-209; 210/435, 446, 451, 455,
210/464, 466, 469, 473, 474, 477, 482
See application file for complete search history.

(56) **References Cited**

U.S. PATENT DOCUMENTS

247,865 A	10/1881	Wodiska
1,261,558 A	4/1918	Lackland
4,259,188 A	3/1981	Morgan
4,673,501 A	6/1987	Wells et al.
D316,741 S	5/1991	Kurth et al.

5,219,525 A	6/1993	Harrison
D470,912 S	2/2003	Daws et al.
7,926,414 B1	4/2011	Wolcott et al.
D638,517 S	5/2011	Greenway-Balnar et al.
D646,749 S	10/2011	Morad
D675,708 S	2/2013	Smiedt et al.

OTHER PUBLICATIONS

RapidPure water filter brochure—published Oct. 2012 (2 pages).
RapidPure water filter brochure (2 pages).

Primary Examiner — Robin V Webster

(74) *Attorney, Agent, or Firm* — James L. Young; Westman, Champlin & Koehler P.A.

(57) **CLAIM**

The ornamental design for a liquid filter housing, as shown and described.

DESCRIPTION

FIG. 1 is a perspective view of a liquid filter housing showing my new design;
FIG. 2 is a front view thereof;
FIG. 3 is a rear view thereof;
FIG. 4 is a side view thereof (from the left side of FIG. 1);
FIG. 5 is a side view thereof (from the right side of FIG. 1);
FIG. 6 is a top view thereof; and,
FIG. 7 is a bottom view thereof.

The dotted lines form no part of the claimed design.

The long/short dashed lines illustrate a border.

1 Claim, 4 Drawing Sheets

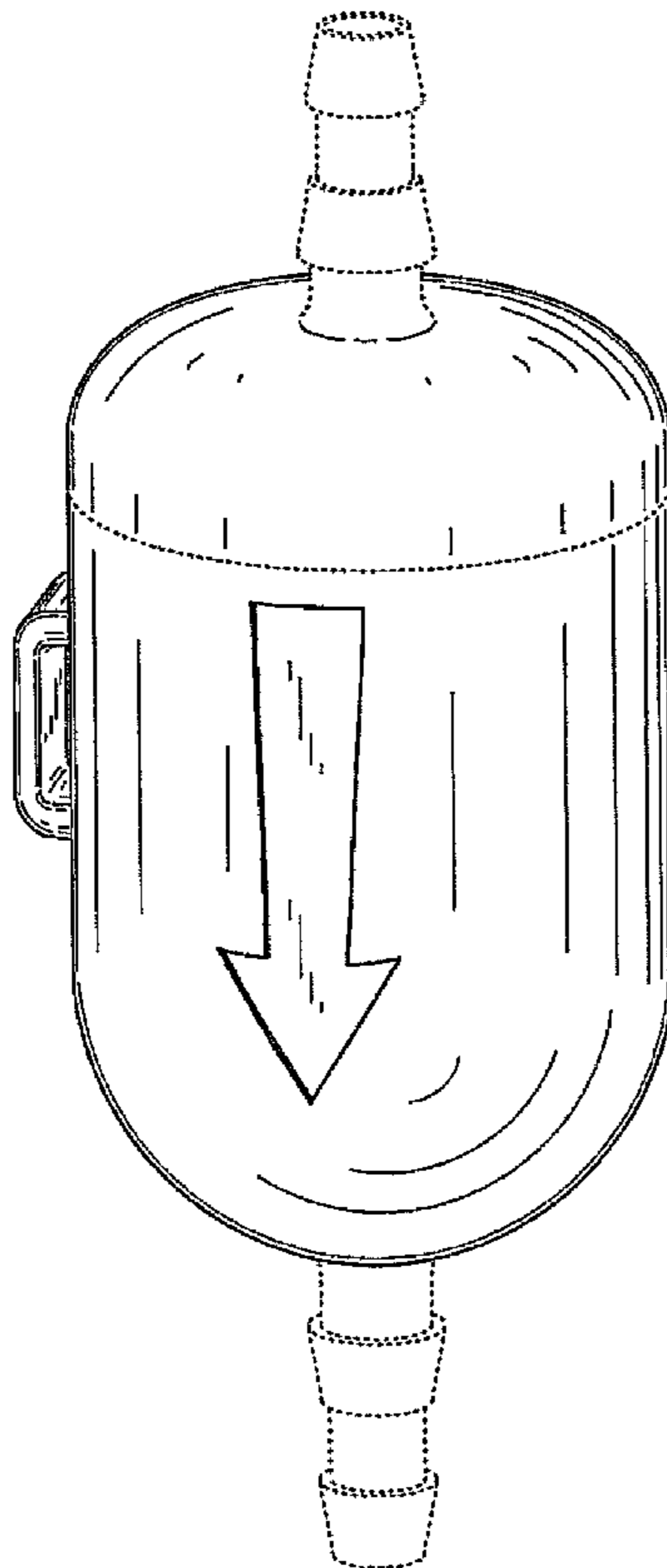

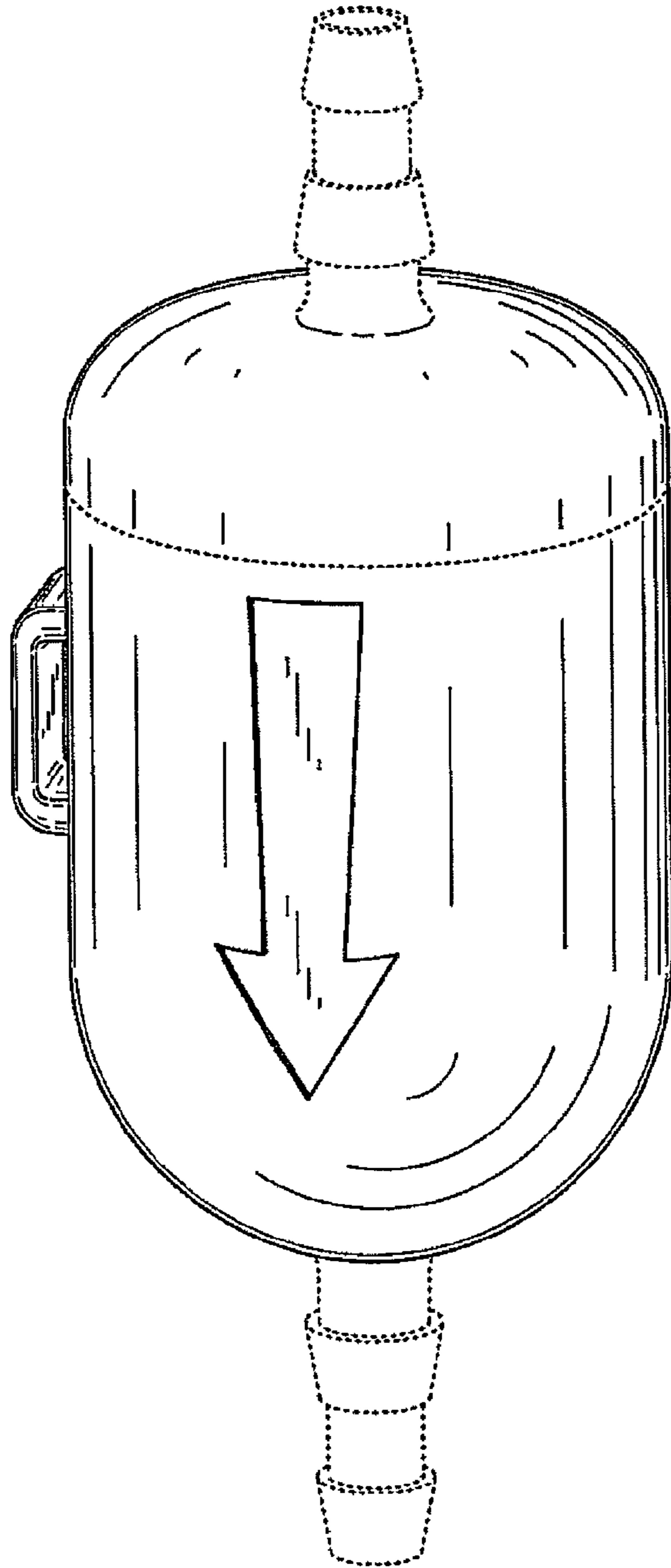

FIG. 1

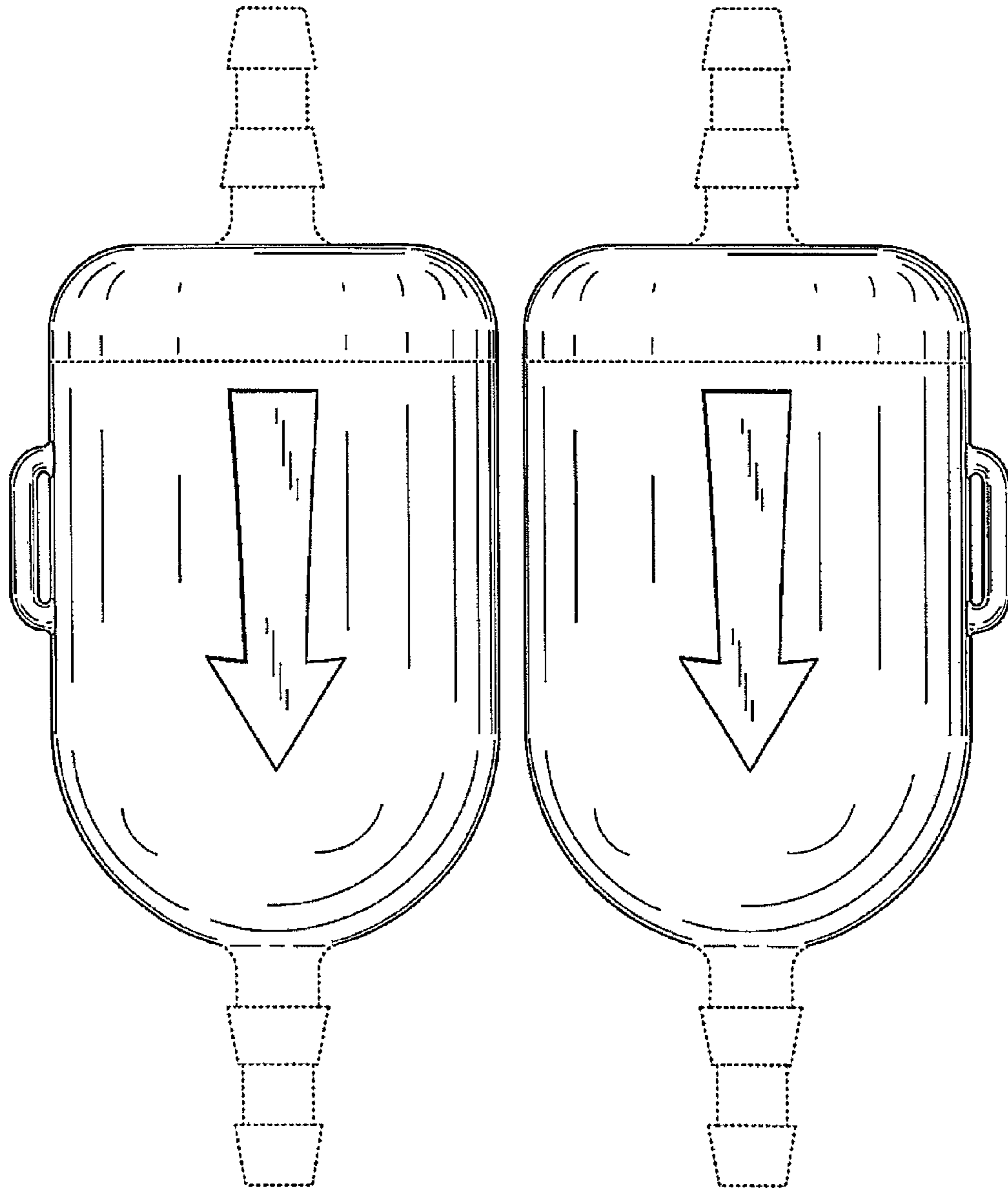

FIG. 2

FIG. 3

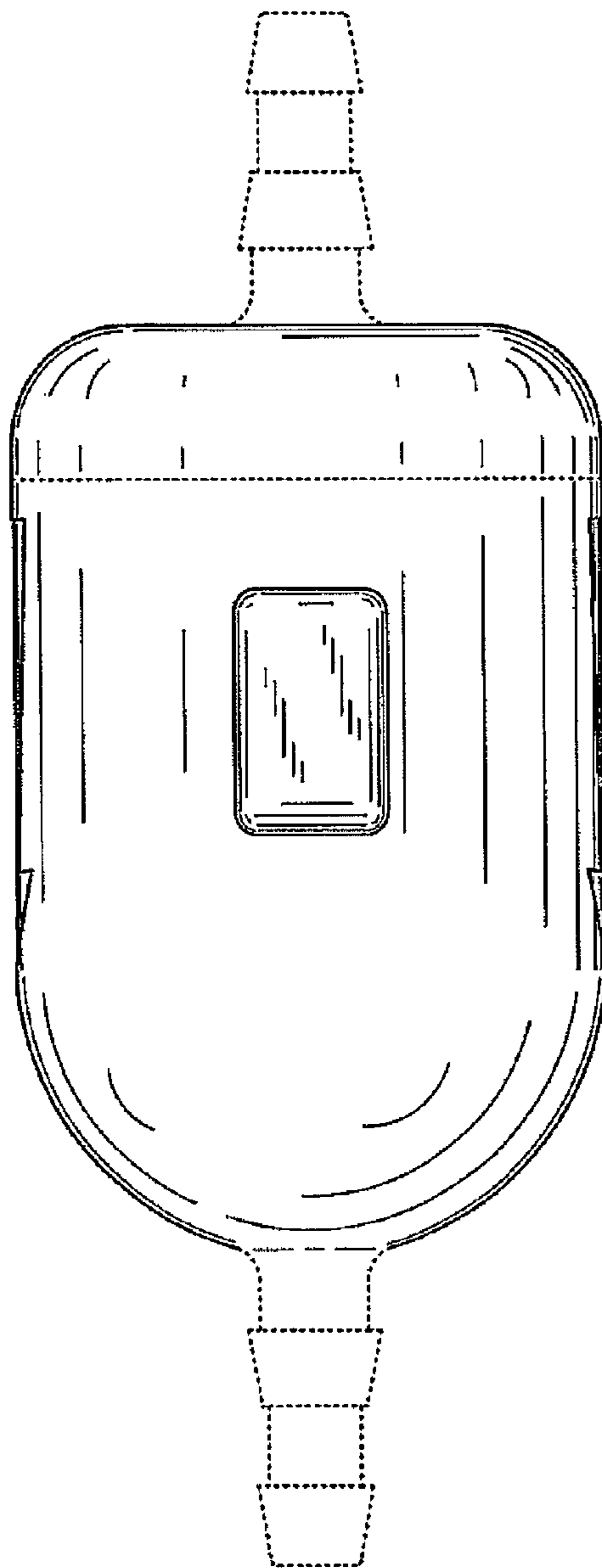

FIG. 4

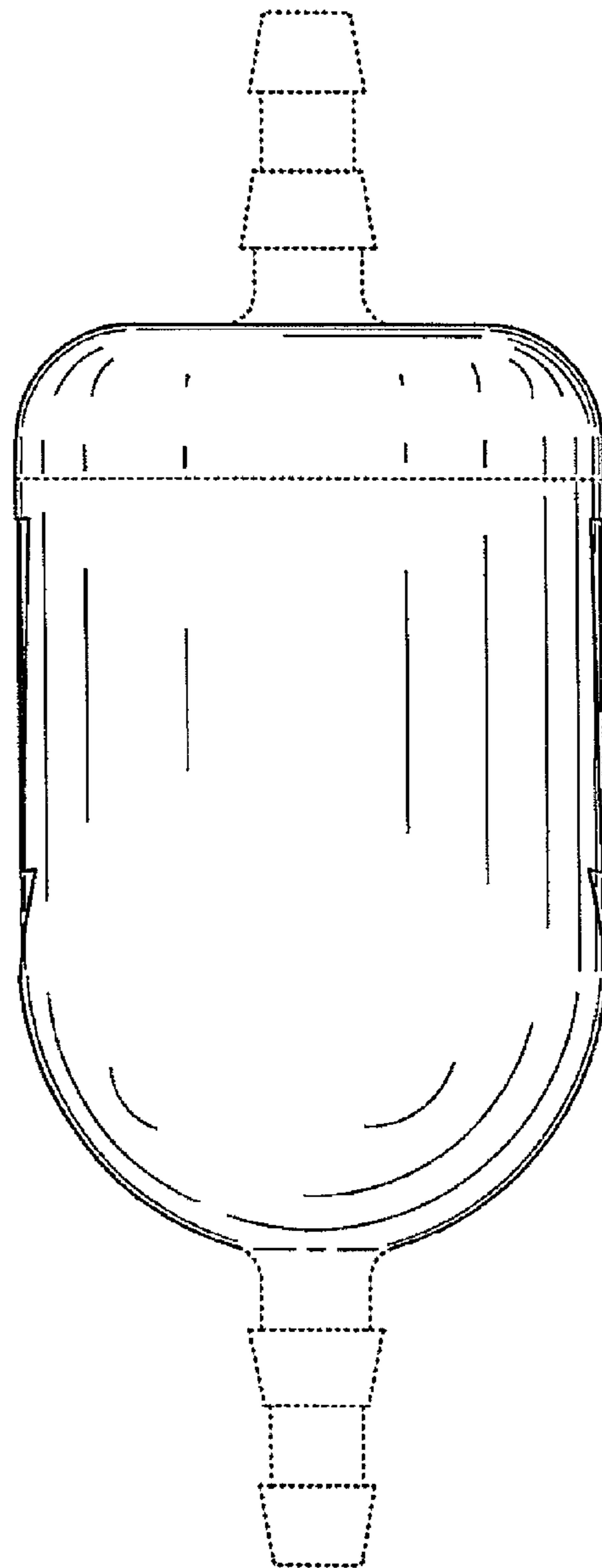

FIG. 5

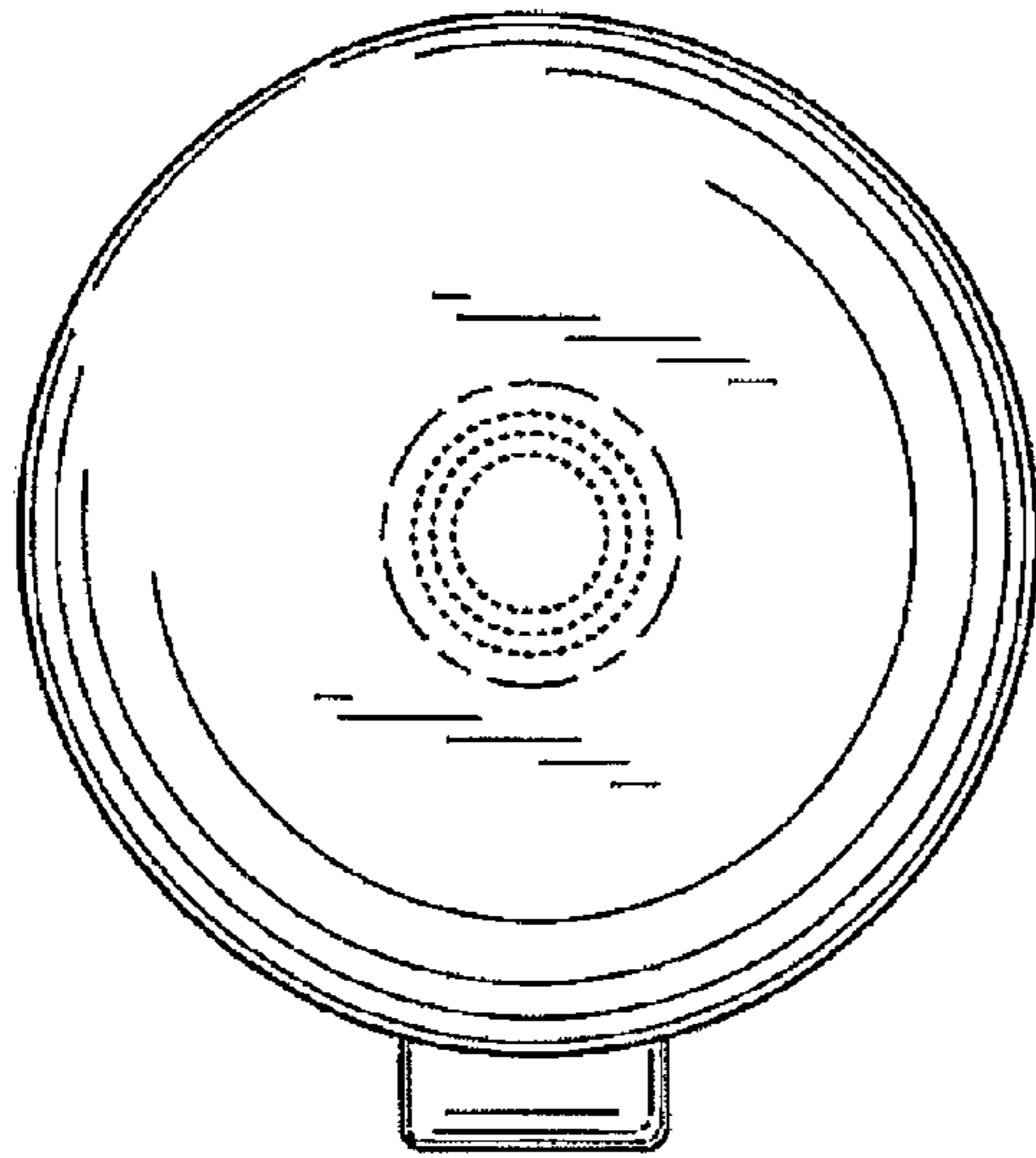

FIG. 6

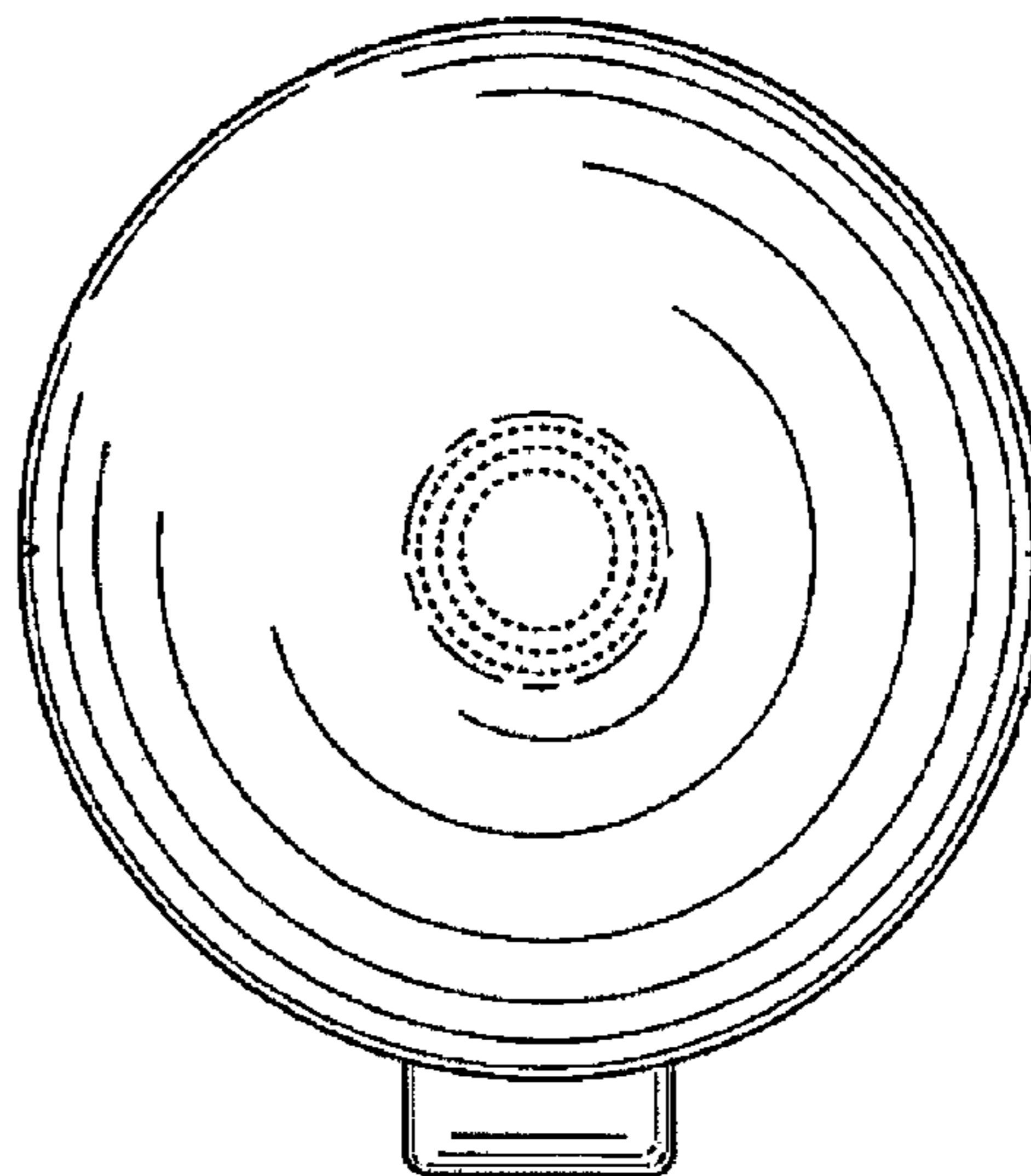

FIG. 7