



US00D726617S

(12) **United States Design Patent**
Dingle et al.

(10) **Patent No.:** **US D726,617 S**

(45) **Date of Patent:** **** Apr. 14, 2015**

(54) **VEHICLE WHEEL**

(75) Inventors: **Matthew Edward Dingle**, Torquay (AU); **Ashley James Denmead**, Belmont (AU); **Michael Dunbar Silcock**, Caulfield North (AU); **Donald Brett Gass**, Forest Lake, MN (US)

(73) Assignee: **Carbon Revolution Pty Ltd**, Melbourne, Victoria (AU)

(**) Term: **14 Years**

(21) Appl. No.: **29/424,581**

(22) Filed: **Jun. 13, 2012**

(51) **LOC (10) Cl.** **12-16**

(52) **U.S. Cl.**
USPC **D12/209**

(58) **Field of Classification Search**
CPC B60B 7/00; B60B 7/02; B60B 7/04; B60B 7/01; B60B 7/06; B60B 3/02; B60B 3/04; B60B 3/06; B60B 3/10; B60B 1/00; B60B 1/08; B60B 1/10; B60B 1/12
USPC D12/204–213
See application file for complete search history.

(56) **References Cited**

U.S. PATENT DOCUMENTS

D457,118 S * 5/2002 Bhambra D12/211
D520,435 S * 5/2006 Kulla et al. D12/211

D552,524 S * 10/2007 Tirado D12/209
D597,920 S * 8/2009 Idei D12/211
D599,268 S * 9/2009 Bernoni D12/211
D617,244 S * 6/2010 Zhao D12/209
D619,075 S * 7/2010 Zhao D12/211
D623,111 S * 9/2010 Spoerle D12/211
D625,240 S * 10/2010 George et al. D12/211
D632,239 S * 2/2011 Gallert D12/211
D633,840 S * 3/2011 Johnson D12/209
D638,765 S * 5/2011 Yoon D12/211
D656,445 S * 3/2012 Lee D12/209
D660,220 S * 5/2012 Chan D12/211
D707,609 S * 6/2014 Curtis D12/211

* cited by examiner

Primary Examiner — Stacia Cadmus

(74) *Attorney, Agent, or Firm* — K&L Gates LLP

(57) **CLAIM**

The ornamental design for a vehicle wheel, as shown and described.

DESCRIPTION

FIG. 1 is a perspective view of a vehicle wheel, showing our new design; and

FIG. 2 is a front view thereof; and,

FIG. 3 is a section view taken along the line 3-3 in FIG. 2.

The broken line showing of the rear portion of the wheel, the bolt holes and the center hole in the central hub area is included for the purpose of illustrating environment and forms no part of the claimed design.

1 Claim, 2 Drawing Sheets

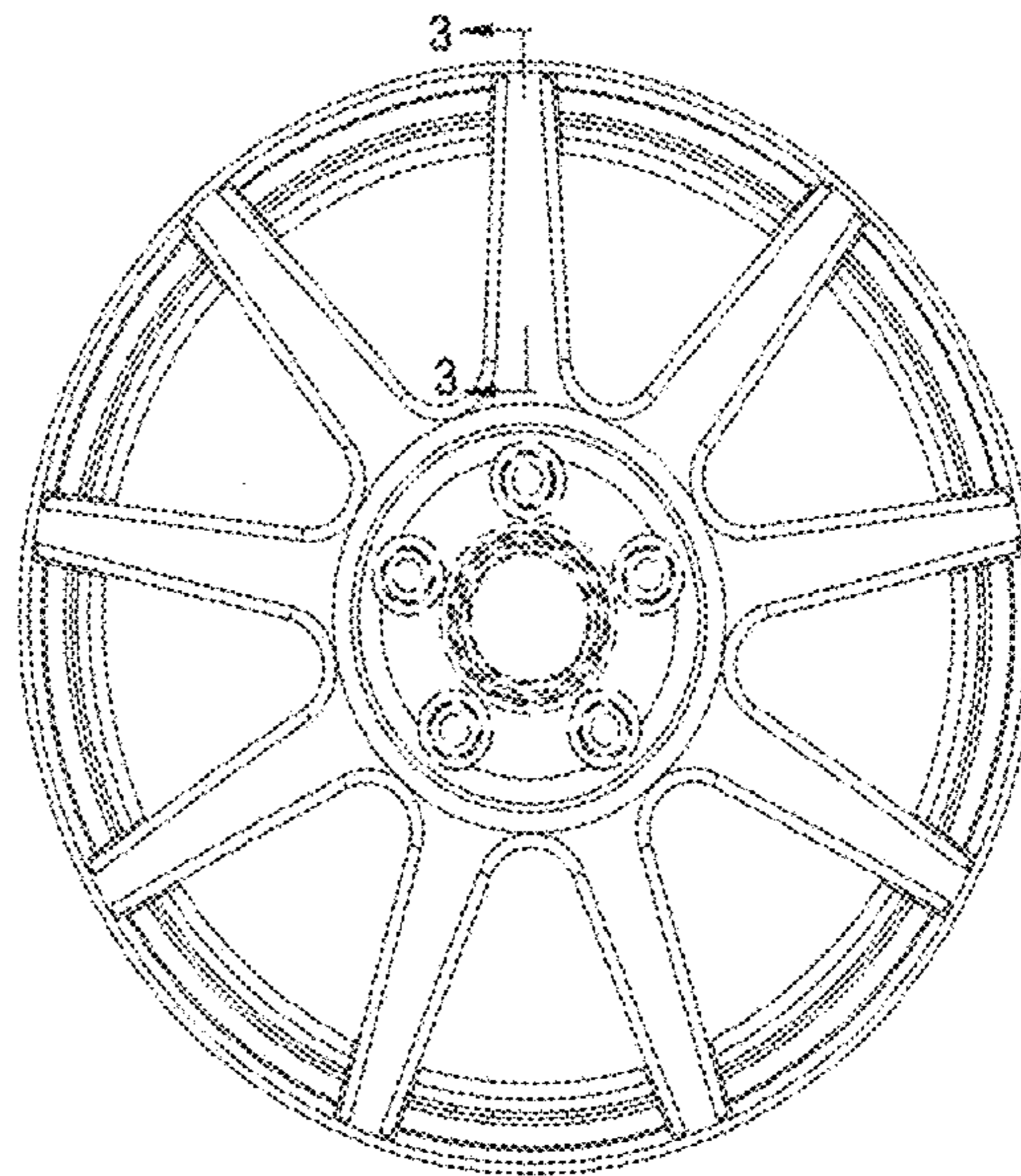
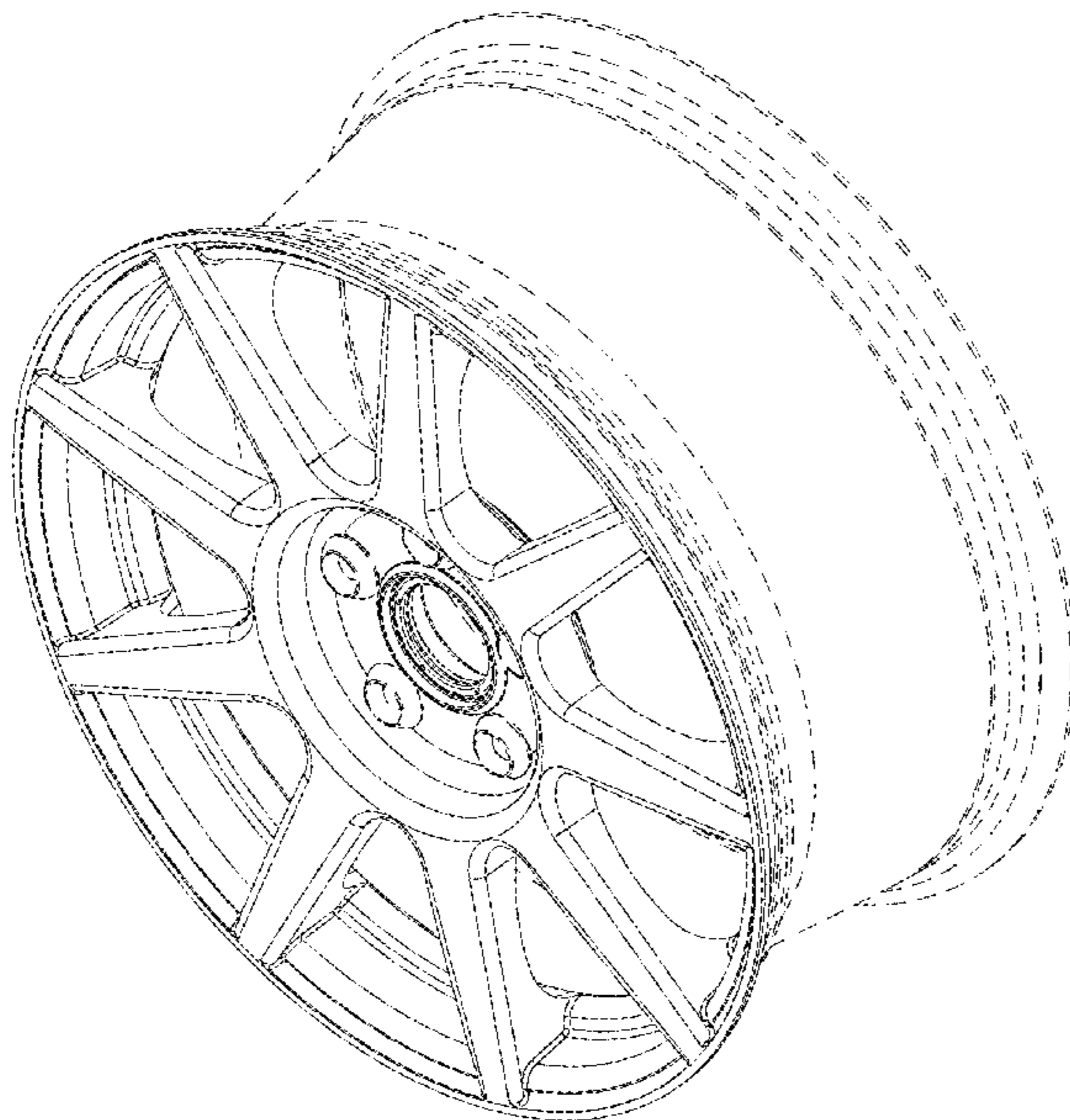

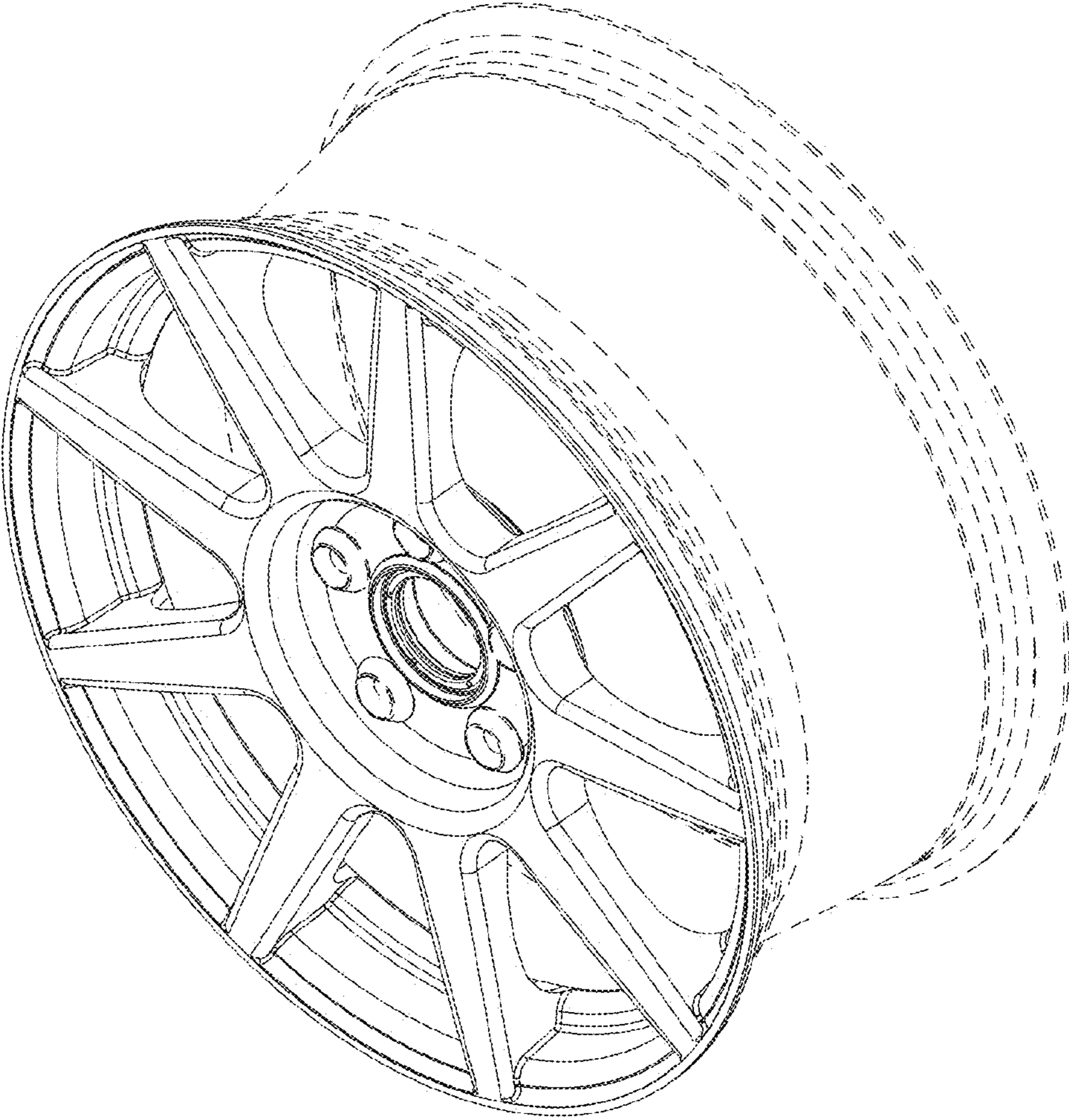

FIG 1

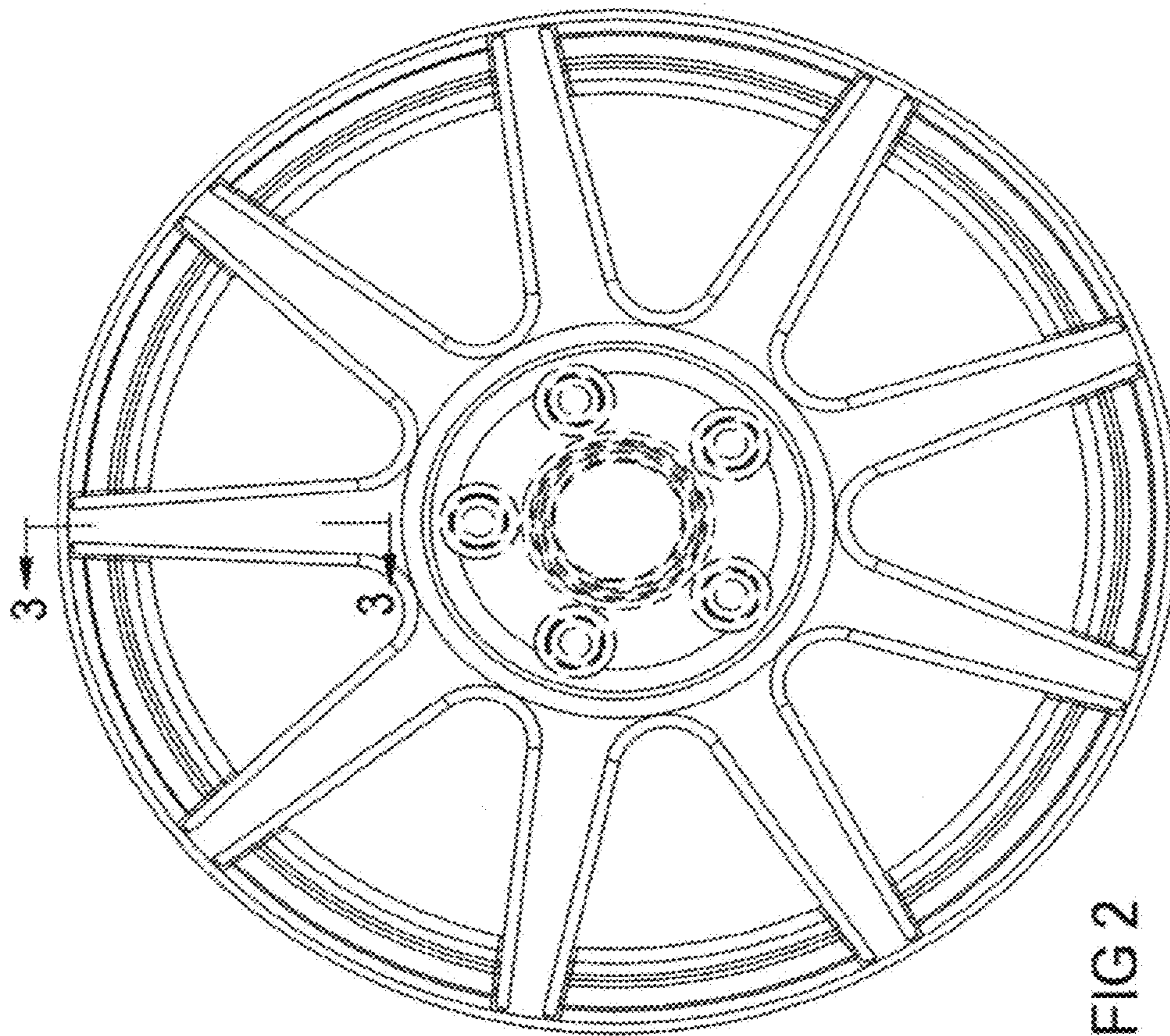

FIG 2



FIG 3