



US00D726606S

(12) **United States Design Patent**  
**Rupar et al.**

(10) **Patent No.:** **US D726,606 S**  
(45) **Date of Patent:** **\*\* Apr. 14, 2015**

(54) **VEHICLE HOOD**

(71) Applicant: **Ford Motor Company**, Dearborn, MI (US)  
(72) Inventors: **Ernesto Rupar**, Cologne (DE); **Dean Carbis**, Cologne (DE)  
(73) Assignee: **Ford Motor Company**, Dearborn, MI (US)

(\*\*) Term: **14 Years**

(21) Appl. No.: **29/482,050**

(22) Filed: **Feb. 13, 2014**

(51) **LOC (10) Cl.** ..... **12-16**

(52) **U.S. Cl.**  
USPC ..... **D12/173**

(58) **Field of Classification Search**  
CPC ..... B25D 25/10; B60Q 1/00  
USPC ..... D12/173, 196, 86, 90-92, 181;  
180/69.21, 69.2, 69.22  
See application file for complete search history.

(56) **References Cited**

**U.S. PATENT DOCUMENTS**

D520,921 S \* 5/2006 Nagura et al. .... D12/173  
D545,249 S \* 6/2007 Fujimaki ..... D12/173

D555,554 S \* 11/2007 Bucher et al. .... D12/173  
D563,293 S \* 3/2008 Pfeiffer ..... D12/173  
D570,753 S \* 6/2008 Sato et al. .... D12/173  
D600,610 S \* 9/2009 Lamm ..... D12/173  
D620,852 S \* 8/2010 Froehlich ..... D12/173  
D633,014 S \* 2/2011 Bauer et al. .... D12/173  
D644,579 S \* 9/2011 Messale ..... D12/173  
D699,643 S \* 2/2014 Chae ..... D12/173  
D700,117 S \* 2/2014 Rupar ..... D12/173  
D702,164 S \* 4/2014 Campbell et al. .... D12/173  
D712,323 S \* 9/2014 Mays et al. .... D12/173

\* cited by examiner

*Primary Examiner* — Melody Brown

(74) *Attorney, Agent, or Firm* — Damian Porcari

(57) **CLAIM**

The ornamental design for a vehicle hood, as shown and described.

**DESCRIPTION**

FIG. 1 is a perspective view of a vehicle hood;  
FIG. 2 is another perspective view thereof;  
FIG. 3 is a front elevational view thereof;  
FIG. 4 is a left side elevational view thereof;  
FIG. 5 is a right side elevational view thereof;  
FIG. 6 is a top plan view thereof; and,  
FIG. 7 is a bottom plan view thereof.

**1 Claim, 7 Drawing Sheets**

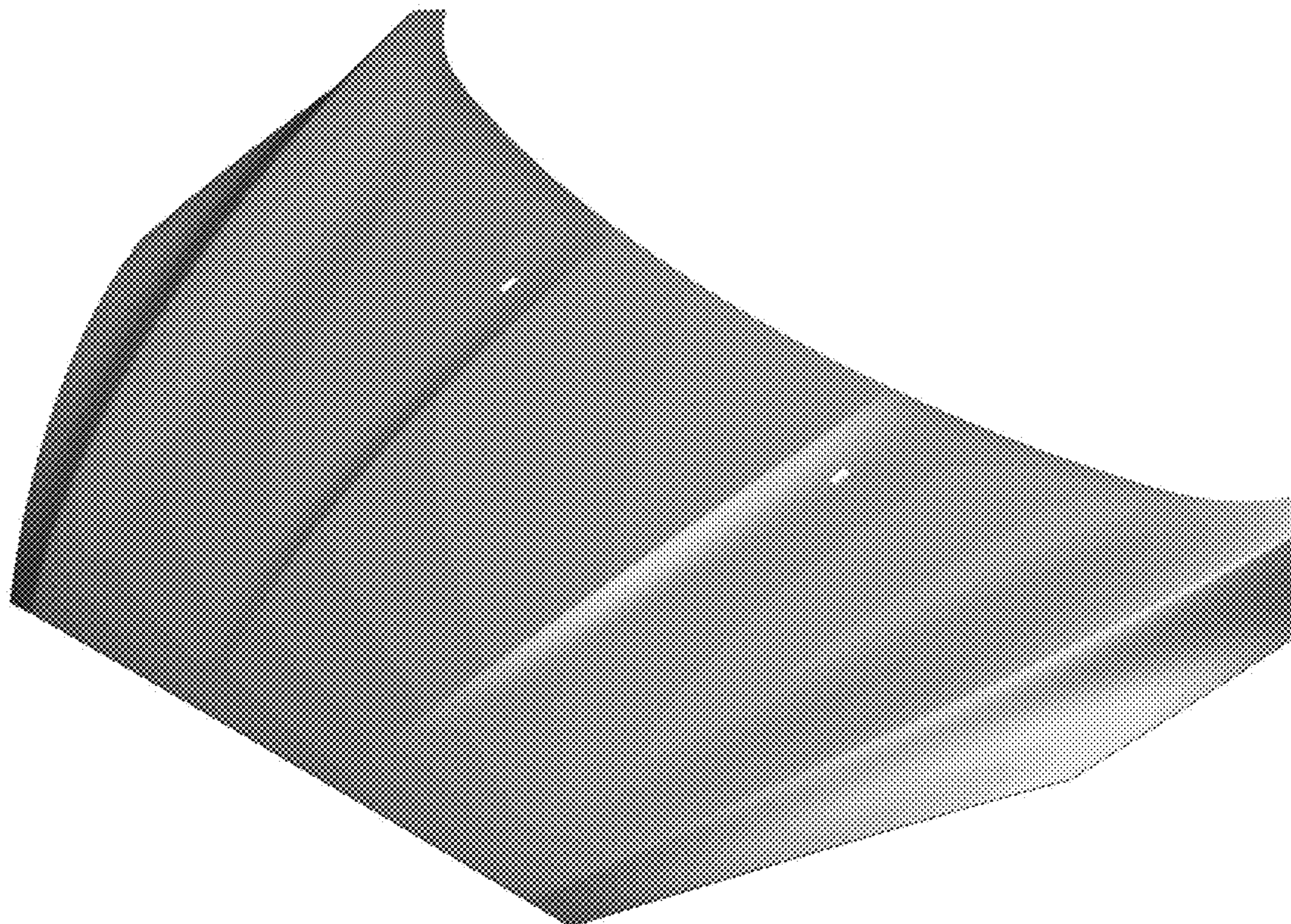

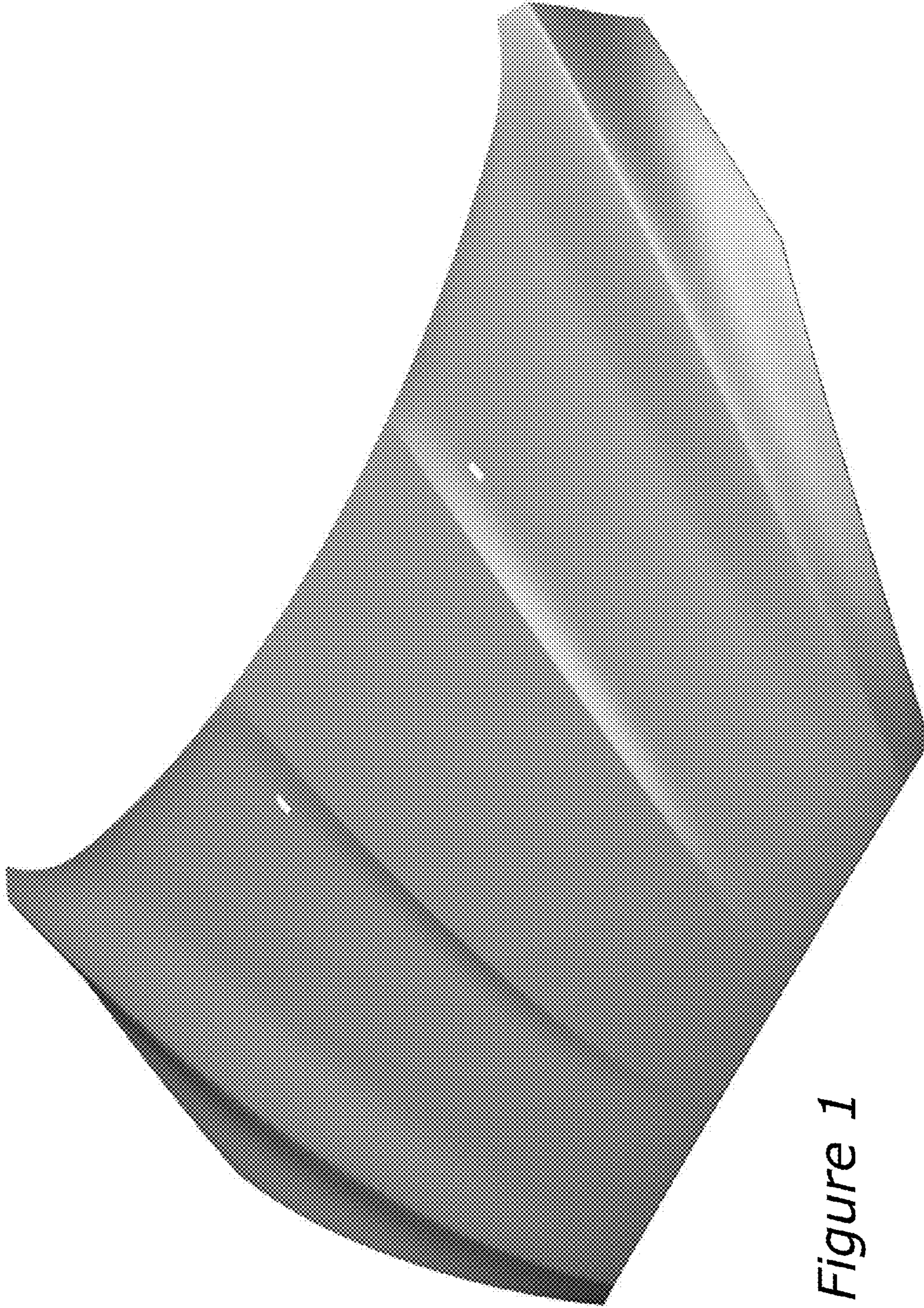

Figure 1

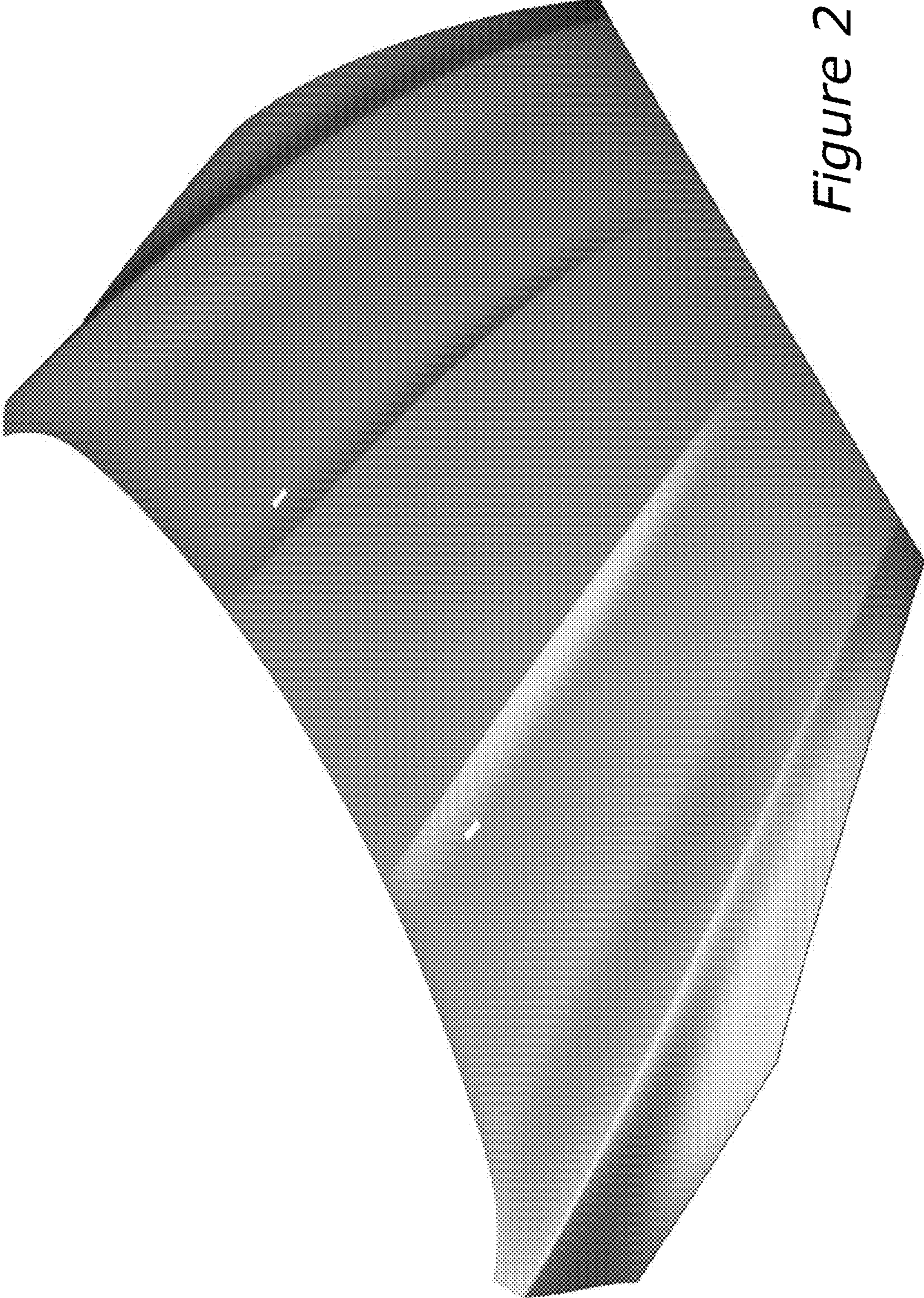

Figure 2

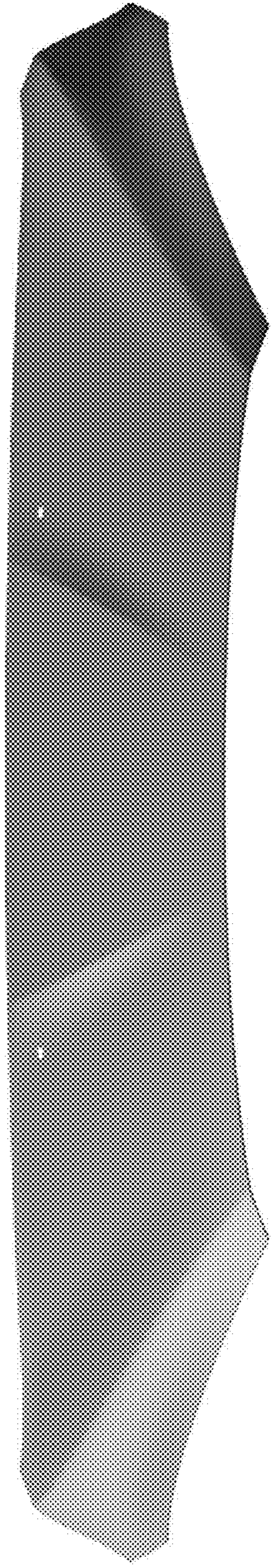

Figure 3

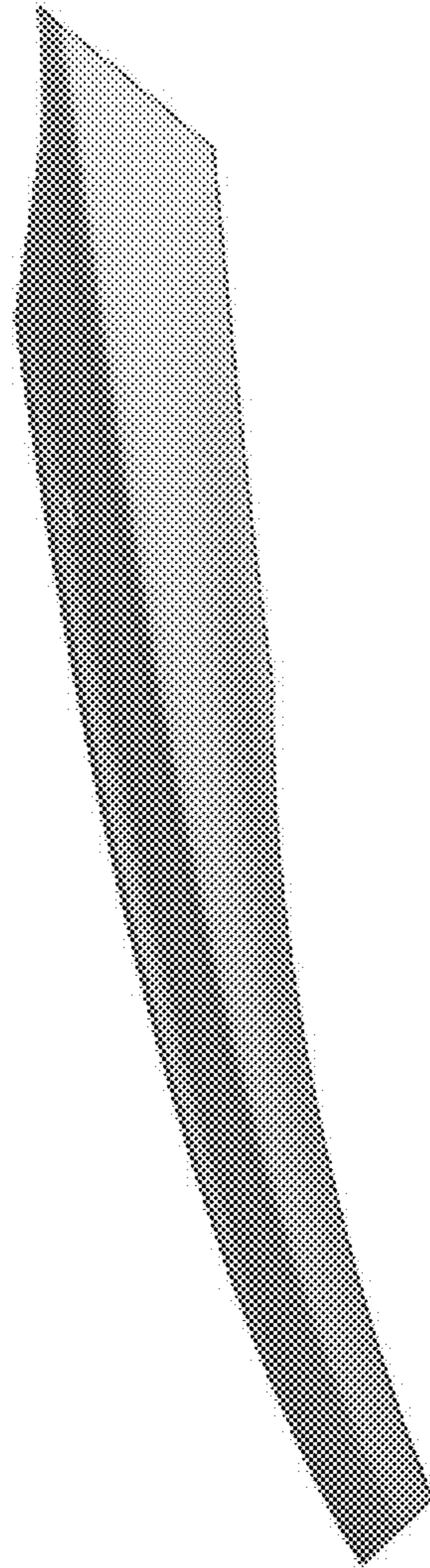

Figure 4

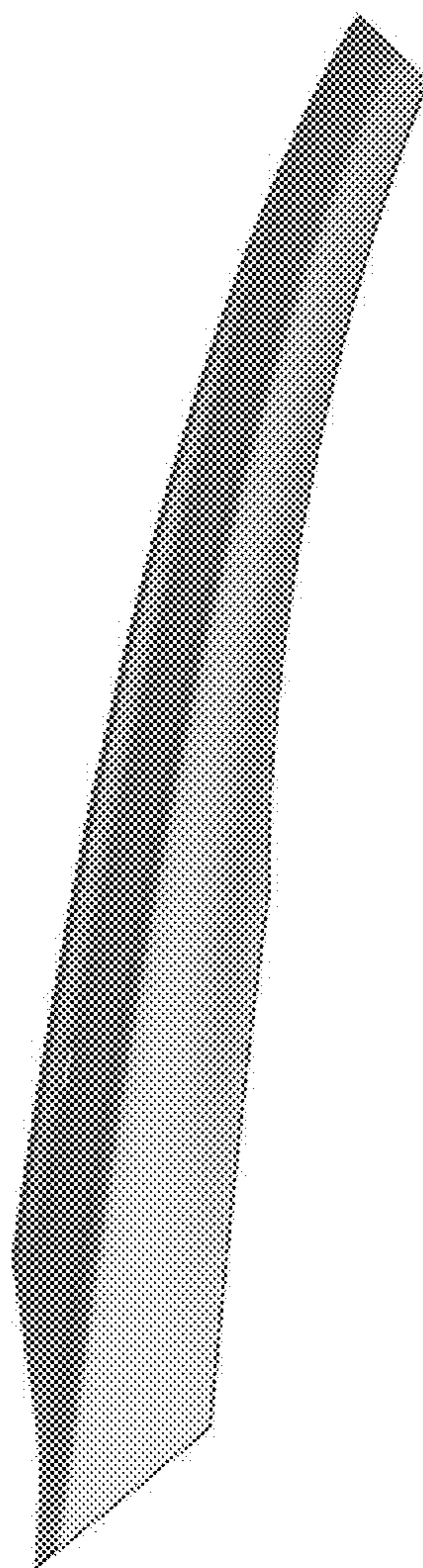

Figure 5

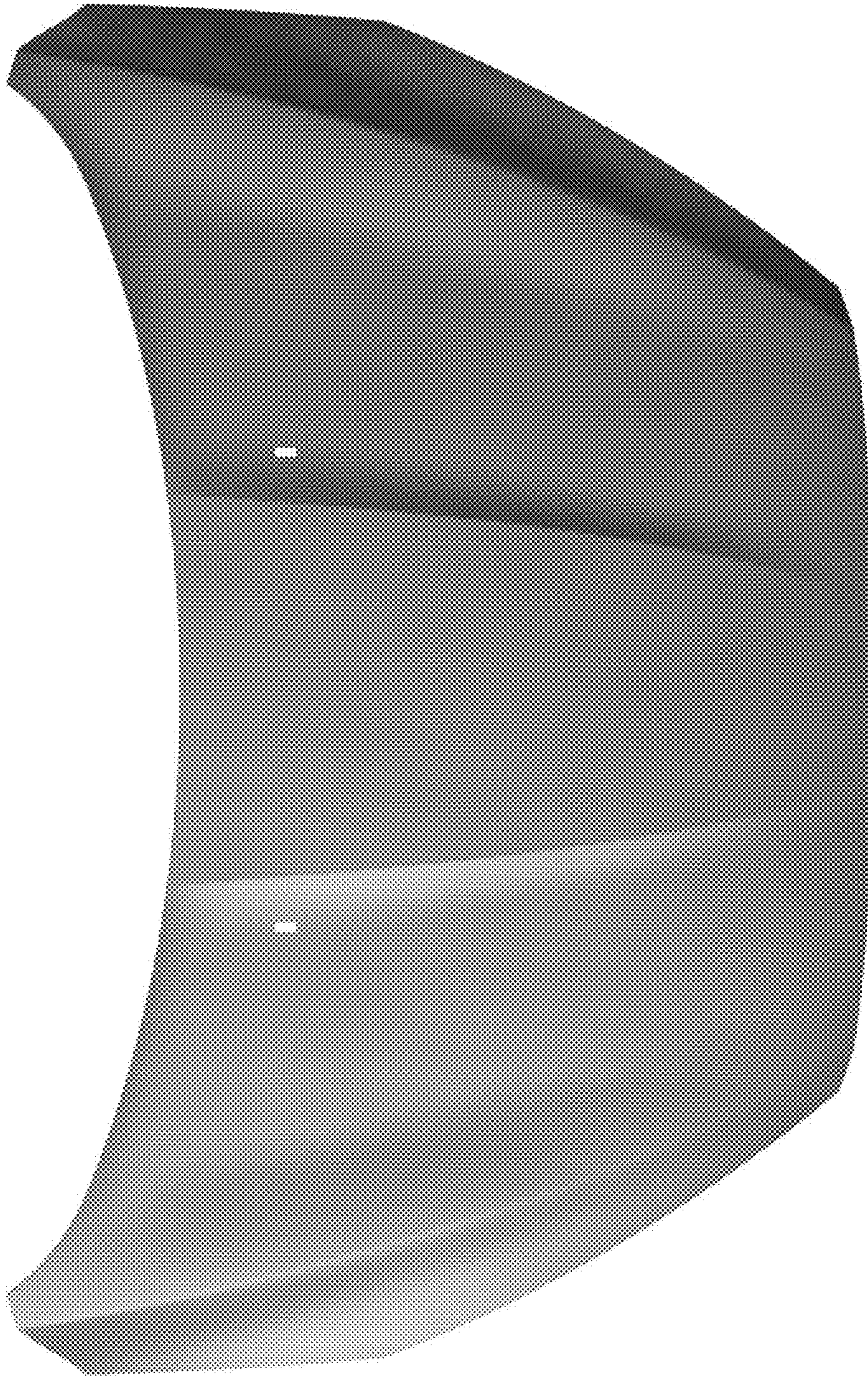

Figure 6

Figure 7

