



US00D726412S

(12) **United States Design Patent**
Fusi

(10) **Patent No.:** **US D726,412 S**
(45) **Date of Patent:** **** Apr. 14, 2015**

(54) **HANDBAG**

- (71) Applicant: **Furla S.p.A.**, S. Lazzaro di Savena (Bologna) (IT)
- (72) Inventor: **Fabio Fusi**, Tavarnelle Val di Pesa (IT)
- (73) Assignee: **Furla S.p.A.**, S. Lazzaro di Savena (IT)
- (**) Term: **14 Years**
- (21) Appl. No.: **29/468,731**
- (22) Filed: **Oct. 2, 2013**

(30) **Foreign Application Priority Data**

May 8, 2013 (EM) 002234302-0001

(51) **LOC (10) Cl.** **03-01**

(52) **U.S. Cl.**
USPC **D3/245**

(58) **Field of Classification Search**

CPC A45C 1/024; A45C 3/06
USPC D3/232-233, 240-243, 245-246;
150/100, 103-110, 113-114, 117-119

See application file for complete search history.

(56) **References Cited**

U.S. PATENT DOCUMENTS

D604,950 S *	12/2009	Greiner	D3/246
D608,087 S *	1/2010	Gonzalez	D3/232
D698,147 S *	1/2014	Deneve	D3/245

* cited by examiner

Primary Examiner — Holly Baynham

(74) *Attorney, Agent, or Firm* — Pearne & Gordon LLP

(57) **CLAIM**

The ornamental design for a handbag, as shown and described.

DESCRIPTION

FIG. 1 is a front-left perspective view of a handbag, showing my new design;

FIG. 2 is a back elevational view thereof;

FIG. 3 is a right side elevational view thereof;

FIG. 4 is a left side elevational view thereof;

FIG. 5 is a top plan view thereof;

FIG. 6 is a bottom plan view thereof; and,

FIG. 7 is a front elevational view thereof.

The broken lines representing stitching are part of the claimed design.

1 Claim, 6 Drawing Sheets



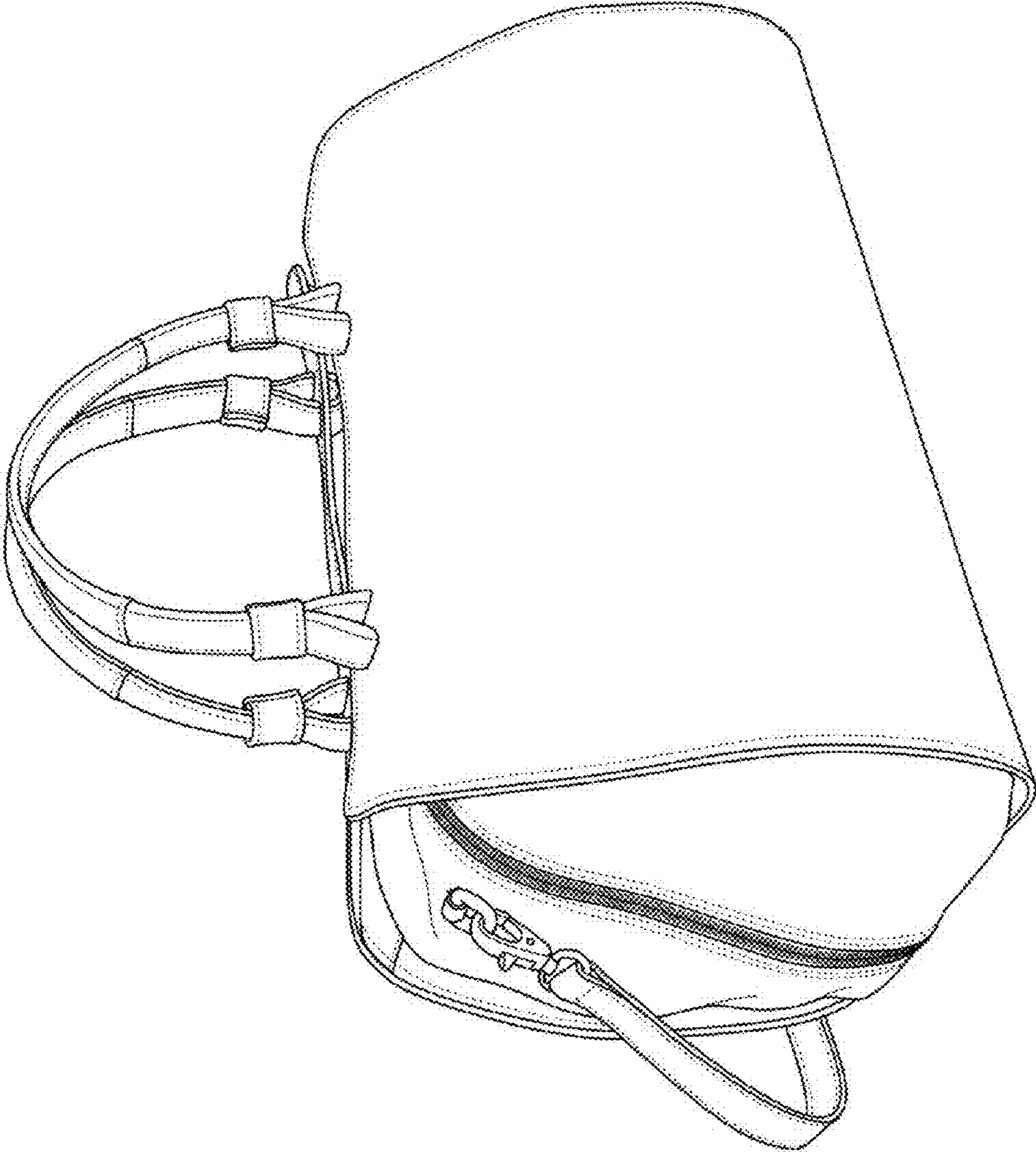

FIG. 1

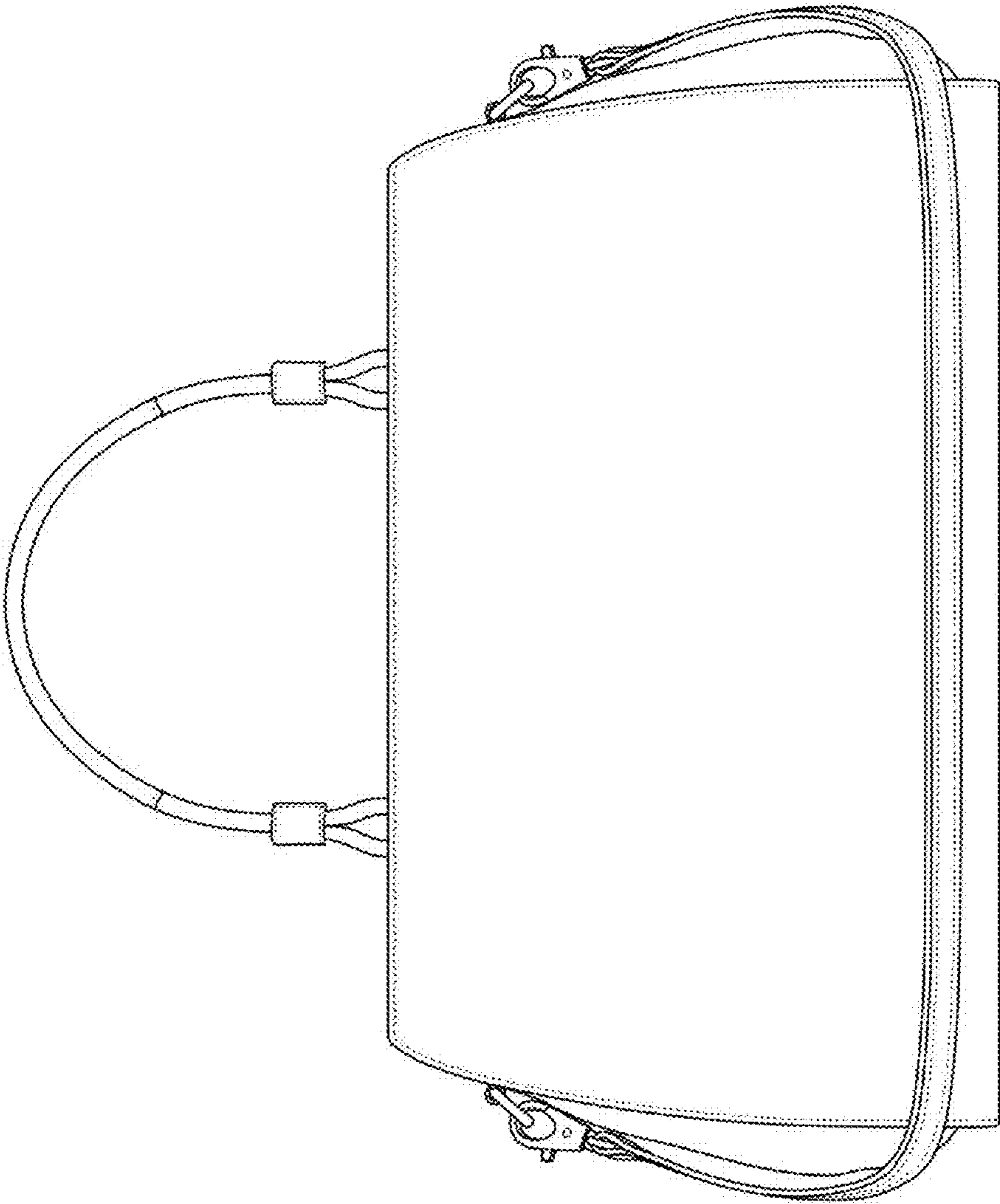

FIG. 2

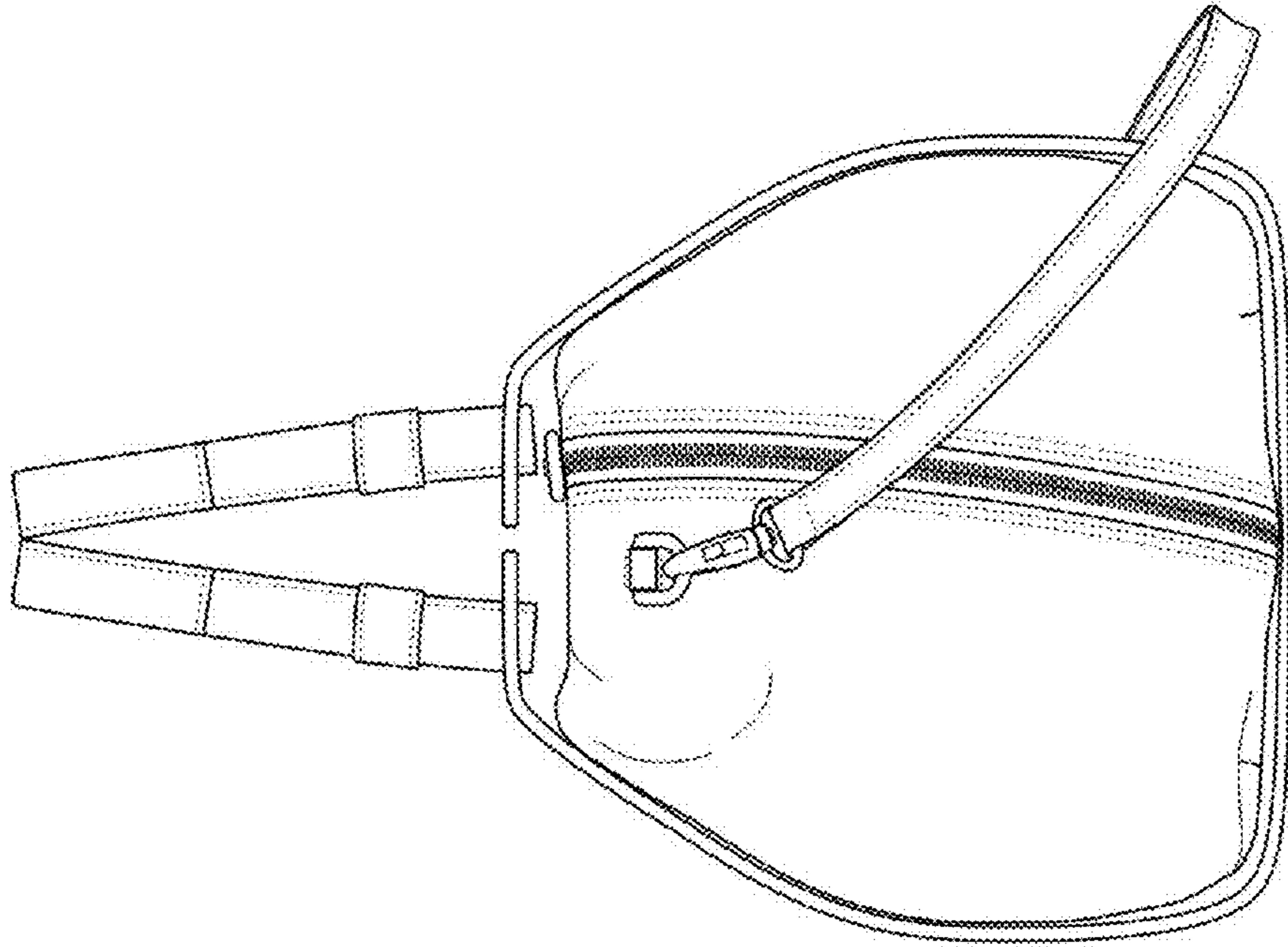

FIG. 4

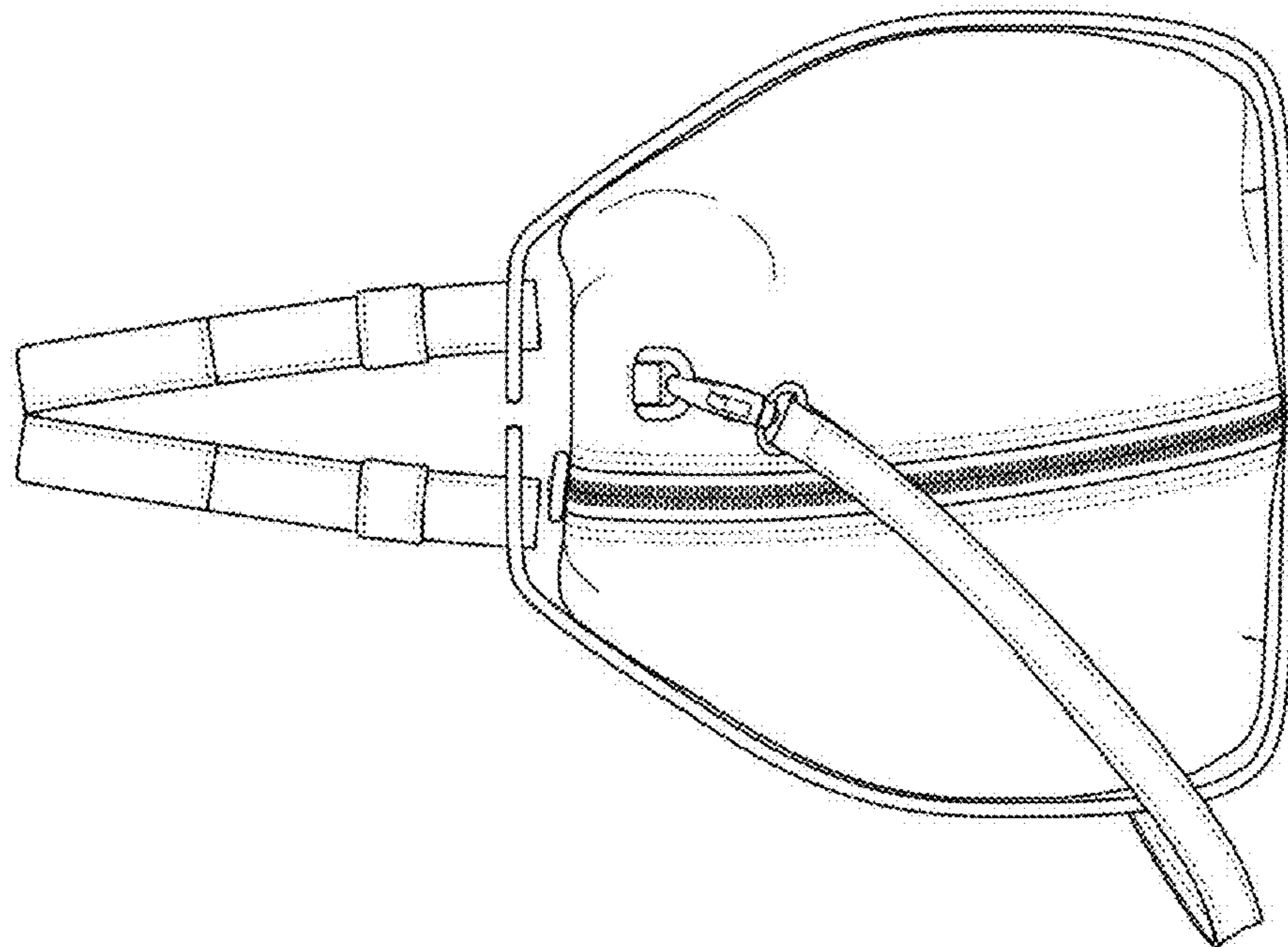

FIG. 3

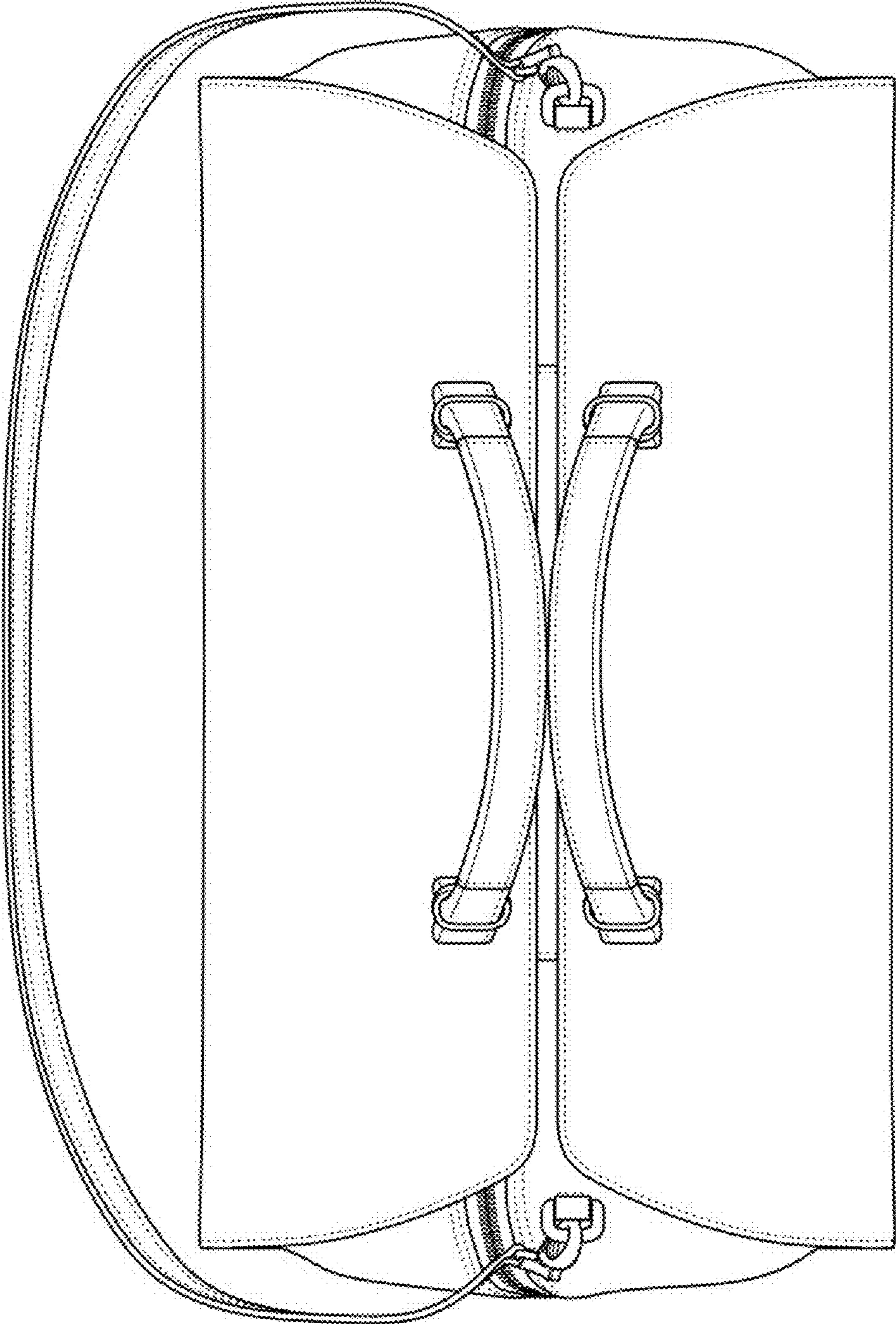

FIG. 5

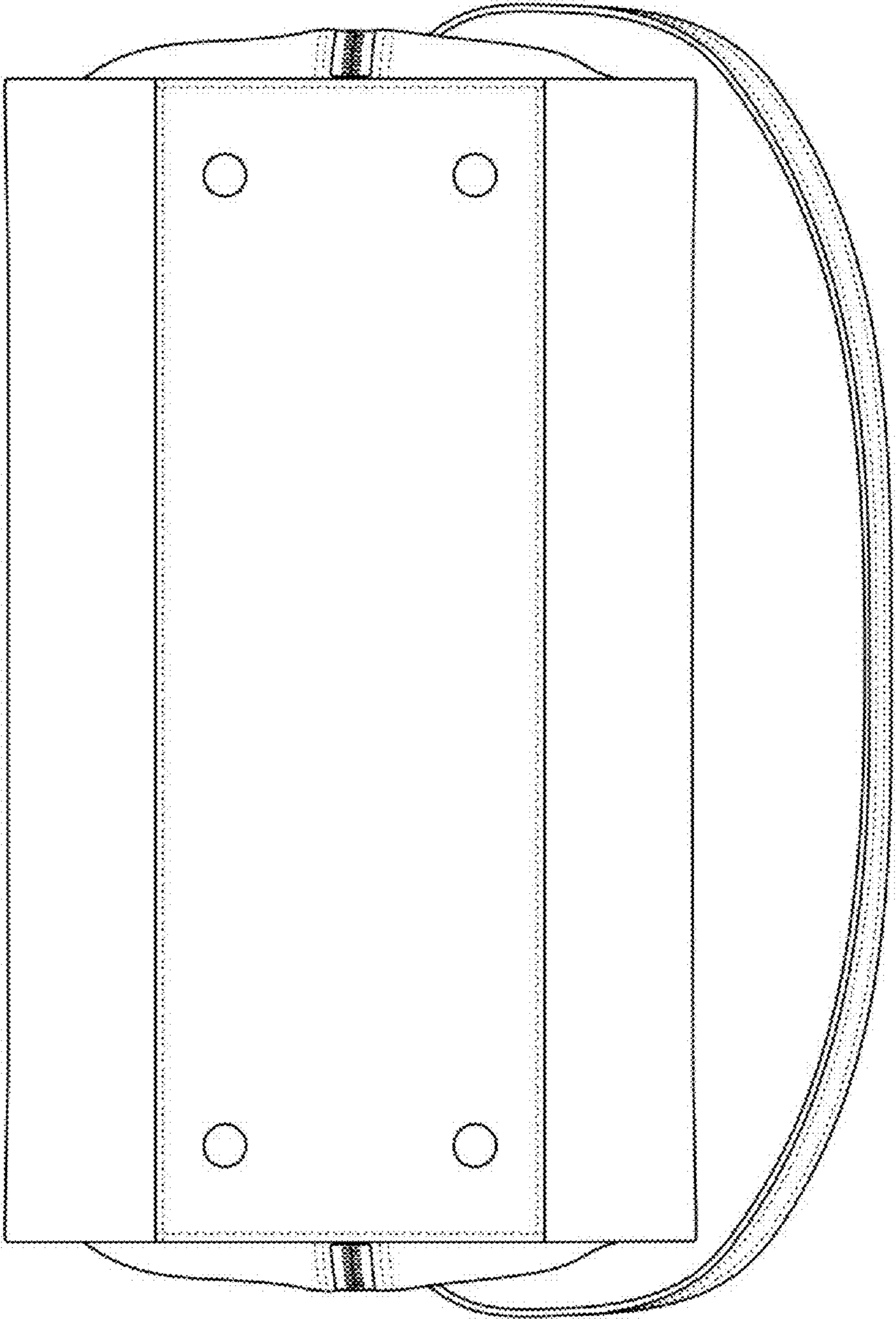

FIG. 6

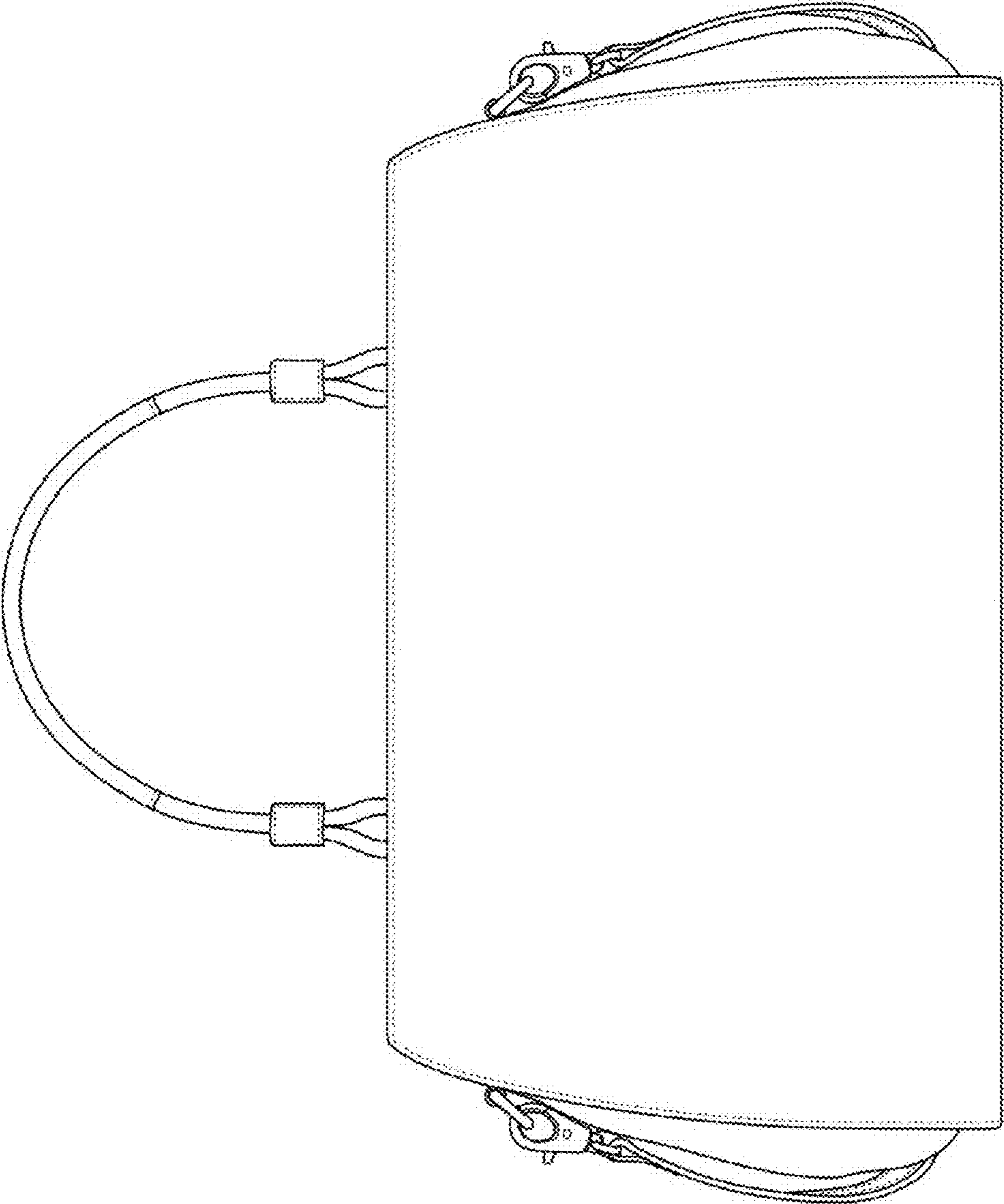

FIG. 7