



US00D726228S

(12) **United States Design Patent**  
**Fukuchi et al.**

(10) **Patent No.:** **US D726,228 S**  
(45) **Date of Patent:** **\*\* Apr. 7, 2015**

(54) **METER PANEL**  
(71) Applicant: **Iseki & Co., Ltd.**, Ehime-ken (JP)  
(72) Inventors: **Kazunori Fukuchi**, Ehime-ken (JP);  
**Takehumi Kato**, Ehime-ken (JP);  
**Yoshitaka Tani**, Ehime-ken (JP)  
(73) Assignee: **Iseki & Co., Ltd.** (JP)  
(\*\*) Term: **14 Years**

D434,425 S \* 11/2000 Rossow et al. .... D15/28  
D436,604 S \* 1/2001 Rossow et al. .... D15/28  
D439,257 S \* 3/2001 Rossow et al. .... D15/28  
D452,693 S \* 1/2002 Mitchell ..... D14/492  
D519,132 S \* 4/2006 Laux et al. .... D15/28  
D527,665 S \* 9/2006 Koide et al. .... D10/103  
D529,052 S \* 9/2006 Dolesh et al. .... D15/28  
D543,558 S \* 5/2007 Dolesh et al. .... D15/28  
D589,388 S \* 3/2009 Sauter ..... D10/102  
D596,145 S \* 7/2009 Vasichek et al. .... D13/177  
D596,146 S \* 7/2009 Vasichek et al. .... D13/177  
D654,415 S \* 2/2012 Mizuno ..... D12/192  
D673,487 S \* 1/2013 Hanson et al. .... D12/192

(21) Appl. No.: **29/466,915**

\* cited by examiner

(22) Filed: **Sep. 12, 2013**

*Primary Examiner* — Mark Goodwin

(30) **Foreign Application Priority Data**

(74) *Attorney, Agent, or Firm* — Finnegan, Henderson, Farabow, Garrett & Dunner, LLP

Jun. 24, 2013 (JP) ..... 201314198

(51) **LOC (10) Cl.** ..... **15-03**

(52) **U.S. Cl.**  
USPC ..... **D15/28**

(58) **Field of Classification Search**  
USPC ..... D15/10, 17, 22–26, 28; D12/190, 192;  
D10/103, 109, 125; D14/101, 102,  
D14/113, 150, 247; D34/35; 180/90, 287;  
296/70

See application file for complete search history.

(56) **References Cited**

U.S. PATENT DOCUMENTS

4,447,860 A \* 5/1984 Stone et al. .... 362/30  
D378,500 S \* 3/1997 Nakai et al. .... D10/125  
D382,569 S \* 8/1997 Esposito ..... D15/28  
D412,157 S \* 7/1999 Stevenson ..... D14/443  
D427,613 S \* 7/2000 Altmann et al. .... D15/28  
D428,022 S \* 7/2000 Altmann et al. .... D15/28

(57) **CLAIM**

The ornamental design for a meter panel, as shown and described.

**DESCRIPTION**

FIG. 1 is a perspective view of the meter panel showing our new design;  
FIG. 2 is a front view thereof;  
FIG. 3 is a right side view thereof;  
FIG. 4 is a left side view thereof;  
FIG. 5 is a rear view thereof;  
FIG. 6 is top plan view thereof;  
FIG. 7 is a bottom view thereof; and,  
FIG. 8 is a reference front view thereof.

The portions depicted in broken lines are environment and the elements depicted in broken lines form no part of the claimed design.

**1 Claim, 8 Drawing Sheets**

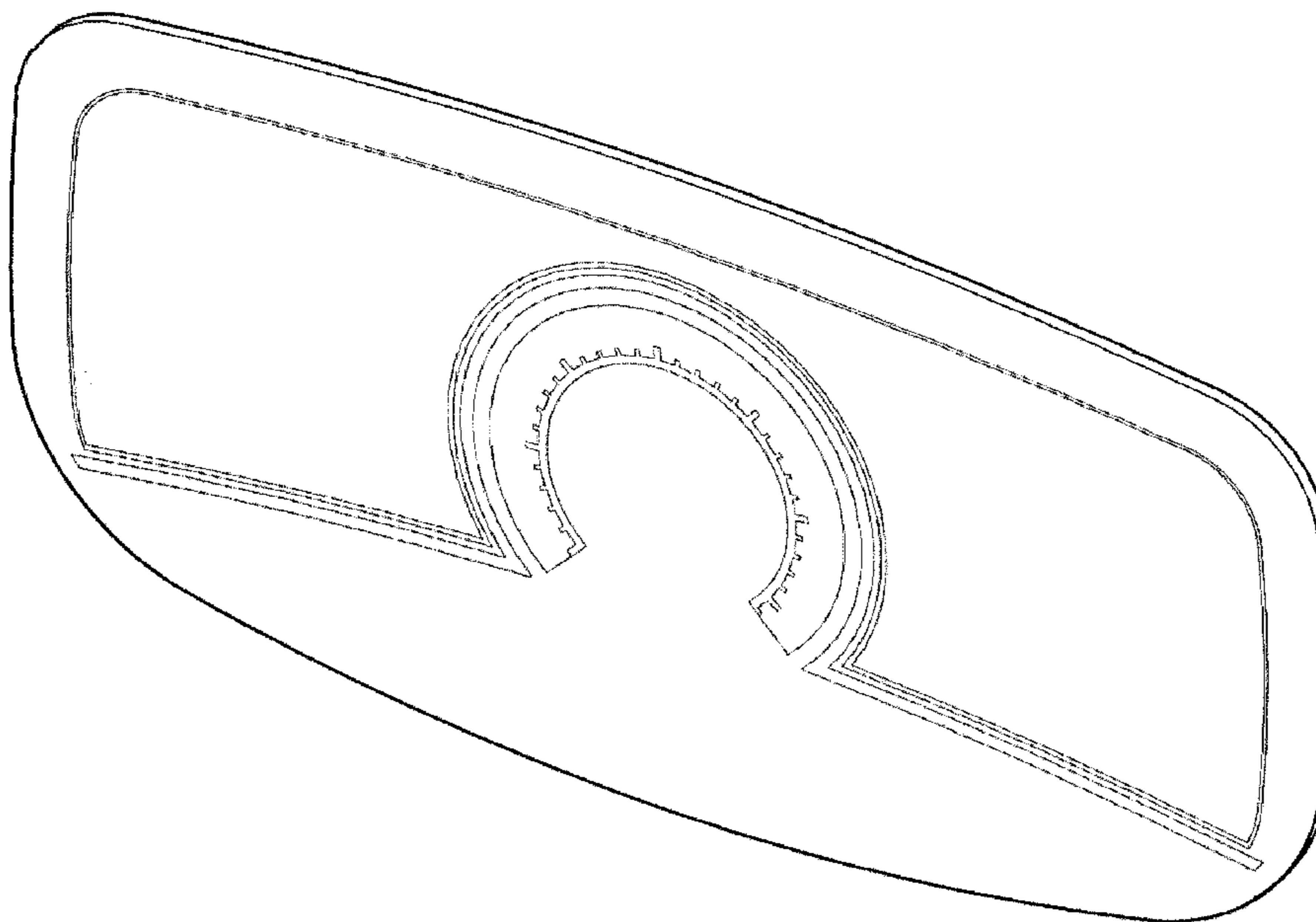

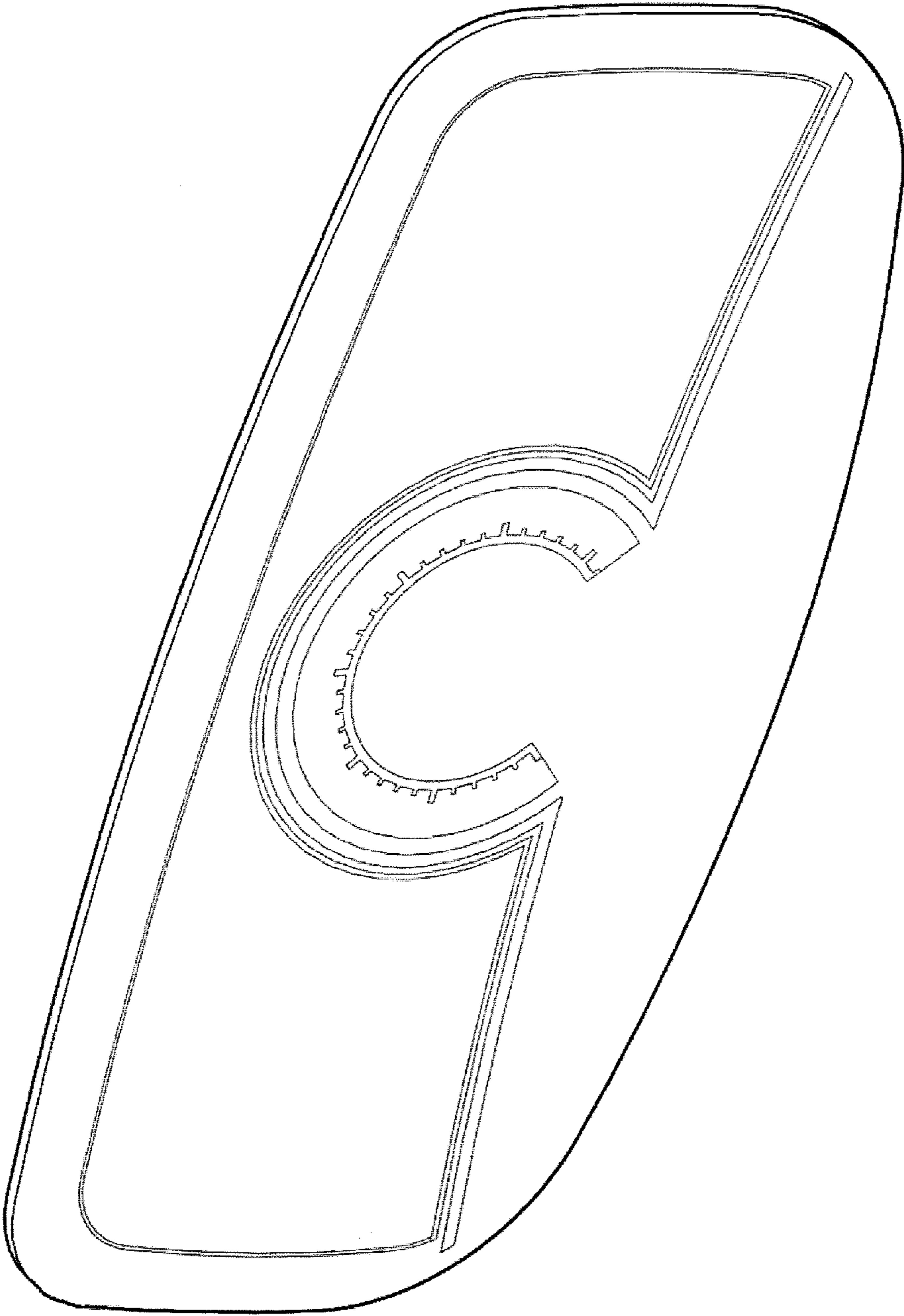

FIG. 1

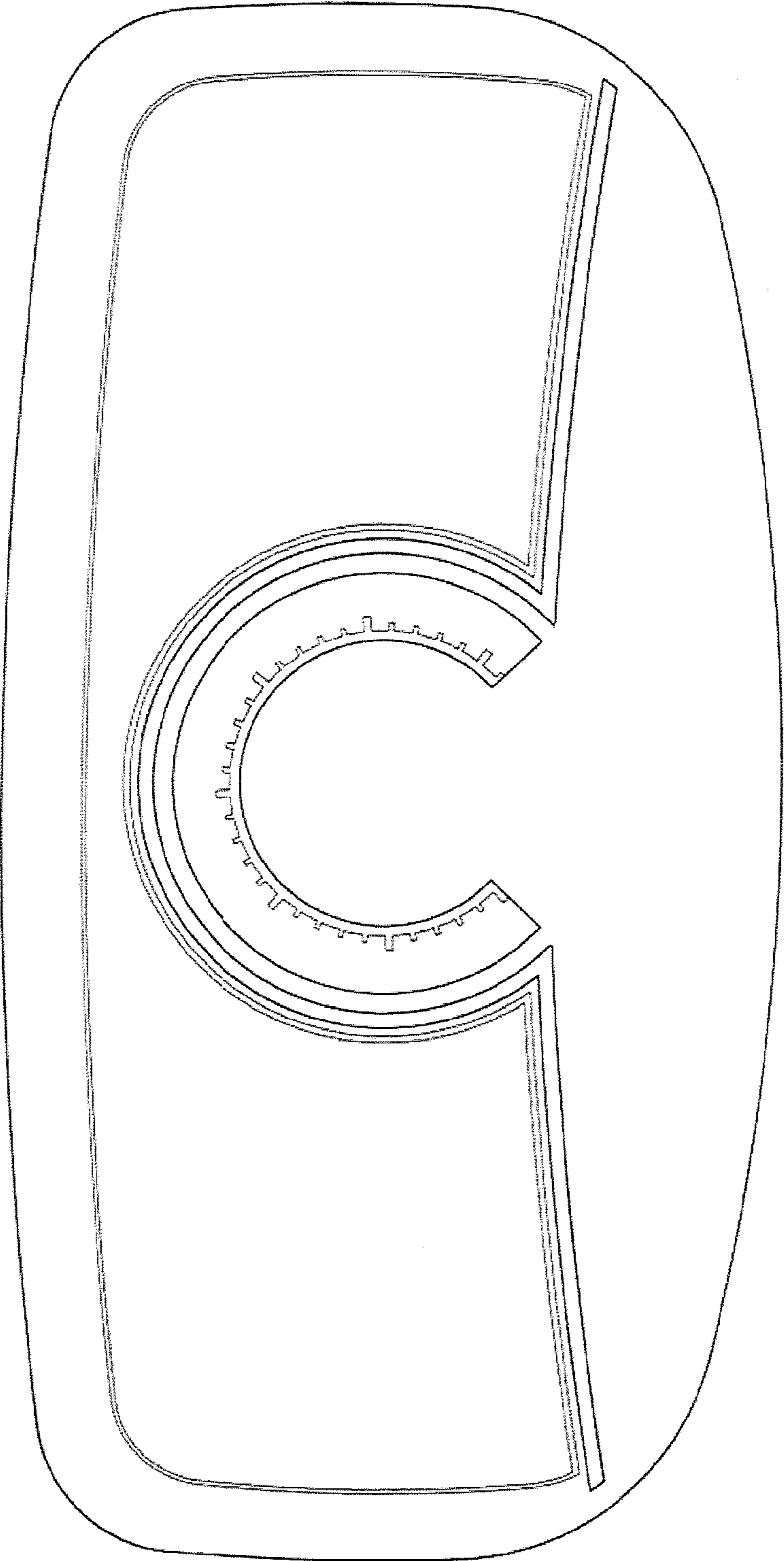
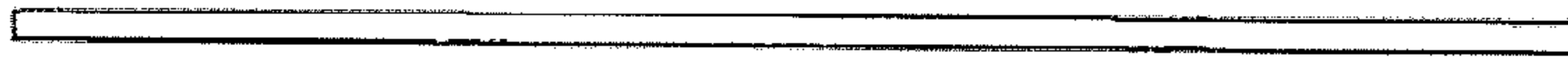
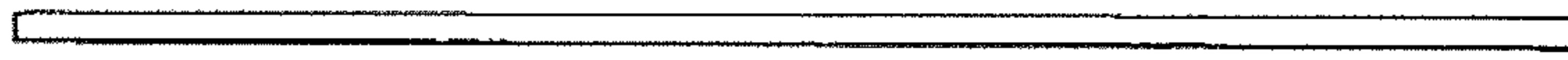

FIG. 2



**FIG. 3**



**FIG. 4**

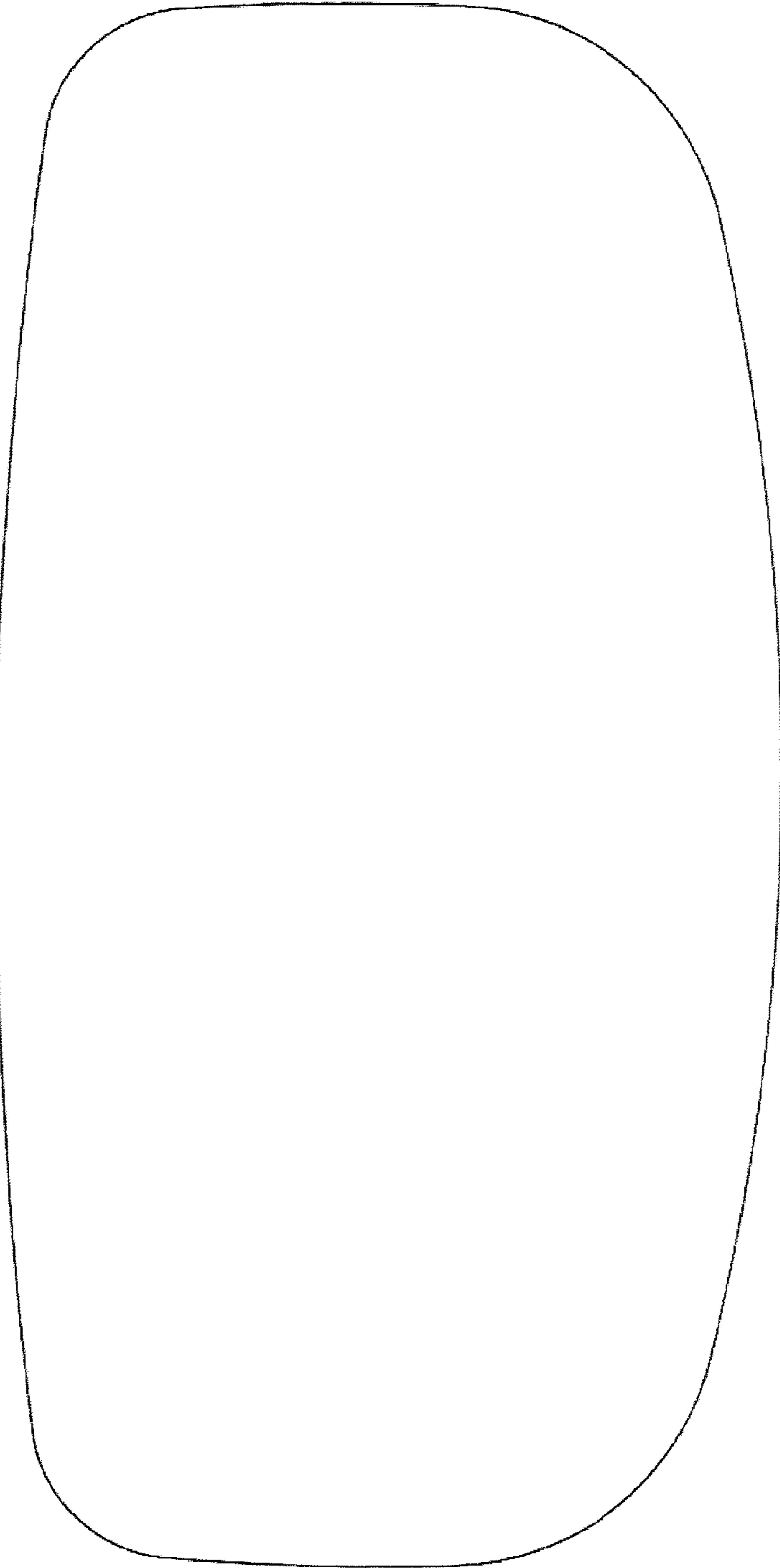

**FIG. 5**



**FIG. 6**



**FIG. 7**



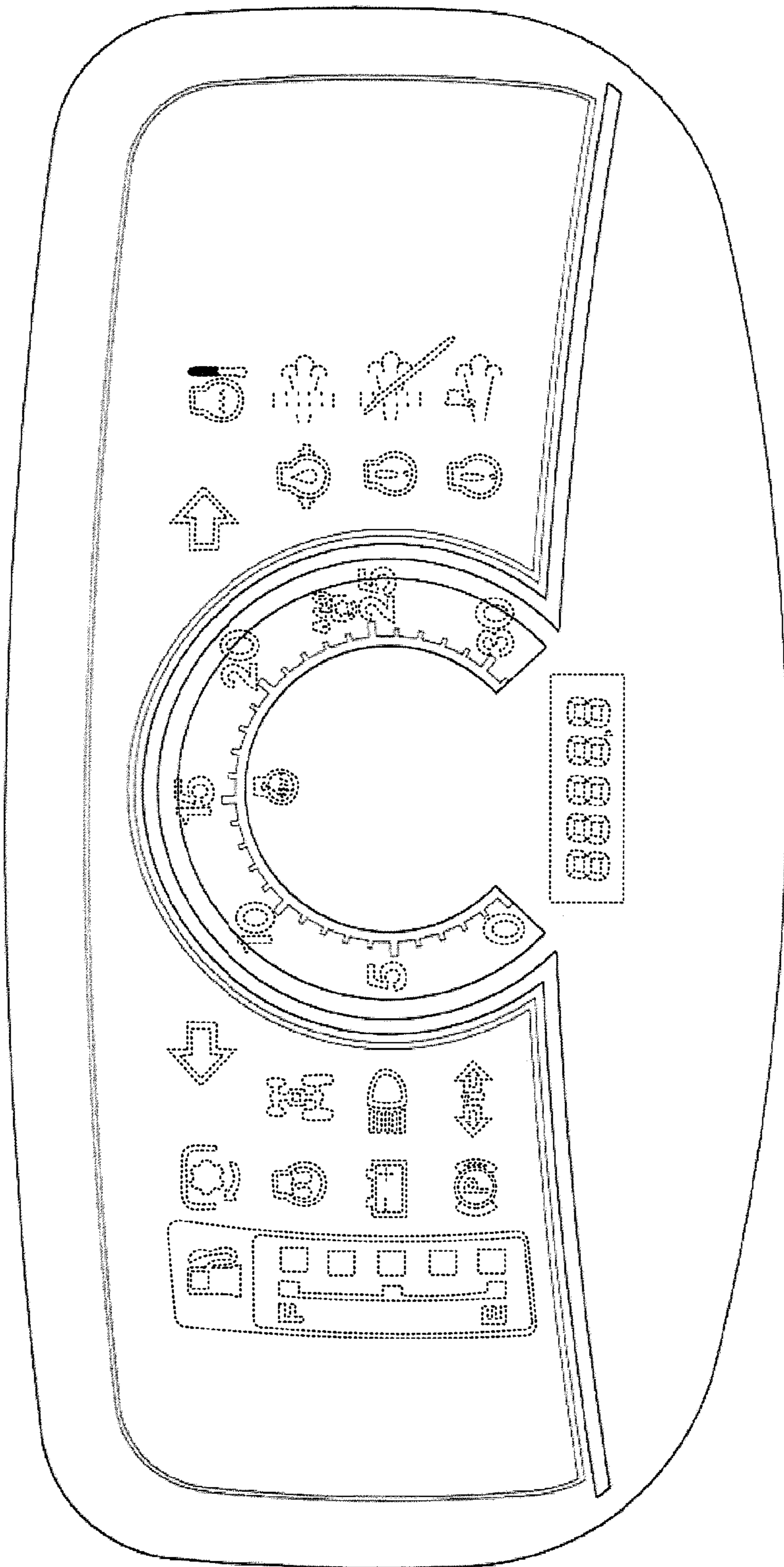

FIG. 8