



US00D726159S

(12) **United States Design Patent**
Swendseid et al.

(10) **Patent No.:** **US D726,159 S**
(45) **Date of Patent:** **** Apr. 7, 2015**

(54) **CONTROL KNOB**

(71) Applicants: **Kent Swendseid**, Woodinville, WA (US); **Timothy E. Cochran**, Woodinville, WA (US)

(72) Inventors: **Kent Swendseid**, Woodinville, WA (US); **Timothy E. Cochran**, Woodinville, WA (US)

(73) Assignee: **LOUD Technologies Inc**, Woodinville, WA (US)

(**) Term: **14 Years**

(21) Appl. No.: **29/446,273**

(22) Filed: **Feb. 21, 2013**

(51) **LOC (10) Cl.** **14-03**

(52) **U.S. Cl.**
USPC **D14/217; D8/311**

(58) **Field of Classification Search**
USPC D14/162, 167, 168, 175, 188, 196–198, D14/217, 257, 258, 388, 389, 434, 453–456, D14/496; D13/163, 164; 84/625, 660, 697; 381/119; 455/350; D8/307, 310, 311, D8/313, 322
See application file for complete search history.

(56) **References Cited**

U.S. PATENT DOCUMENTS

D289,544 S * 4/1987 Doman D23/250
D344,440 S * 2/1994 Oakley D8/311

(Continued)

OTHER PUBLICATIONS

“Alesis MultiMix 8 USB: Multichannel Mixer/Audio Interface,” photograph, 2007, Alesis, Cumberland, R.I., <<http://www.alesis.com/multimix8usb>> [retrieved Jul. 22, 2012], 1 page.

(Continued)

Primary Examiner — Keli L Hill

(74) *Attorney, Agent, or Firm* — Christensen O’Connor Johnson Kindness PLLC

(57) **CLAIM**

The ornamental design for a control knob, as shown and described.

DESCRIPTION

FIG. 1 is a top perspective view of the design of the present application;
FIG. 2 is a front elevational view of FIG. 1;
FIG. 3 is a rear elevational view of FIG. 1;
FIG. 4 is a side elevational view of FIG. 1;
FIG. 5 is an opposite side elevational view of FIG. 1;
FIG. 6 is a top view of the design of FIG. 1;
FIG. 7 is a bottom view of the design of FIG. 1;
FIG. 8 is a bottom perspective view of the design of FIG. 1;
FIG. 9 is a top perspective view of the two components of the design of FIG. 1, shown as disassembled;
FIG. 10 is a top perspective view of a further embodiment of the present design;
FIG. 11 is a front elevational view of the design of FIG. 10;
FIG. 12 is a rear elevational view of the design of FIG. 10;
FIG. 13 is a side elevational view of the design of FIG. 10;
FIG. 14 is an opposite side elevational view of the design of FIG. 10;
FIG. 15 is a top view of the design of FIG. 10;
FIG. 16 is a bottom view of the design of FIG. 10;
FIG. 17 is a bottom perspective view of the design of FIG. 10;
and,
FIG. 18 is a top perspective view of the two components of the design of FIG. 10, shown as disassembled.
The broken lines shown are included for the purpose of illustrating portions of the control knob that form no part of the claim.

1 Claim, 6 Drawing Sheets

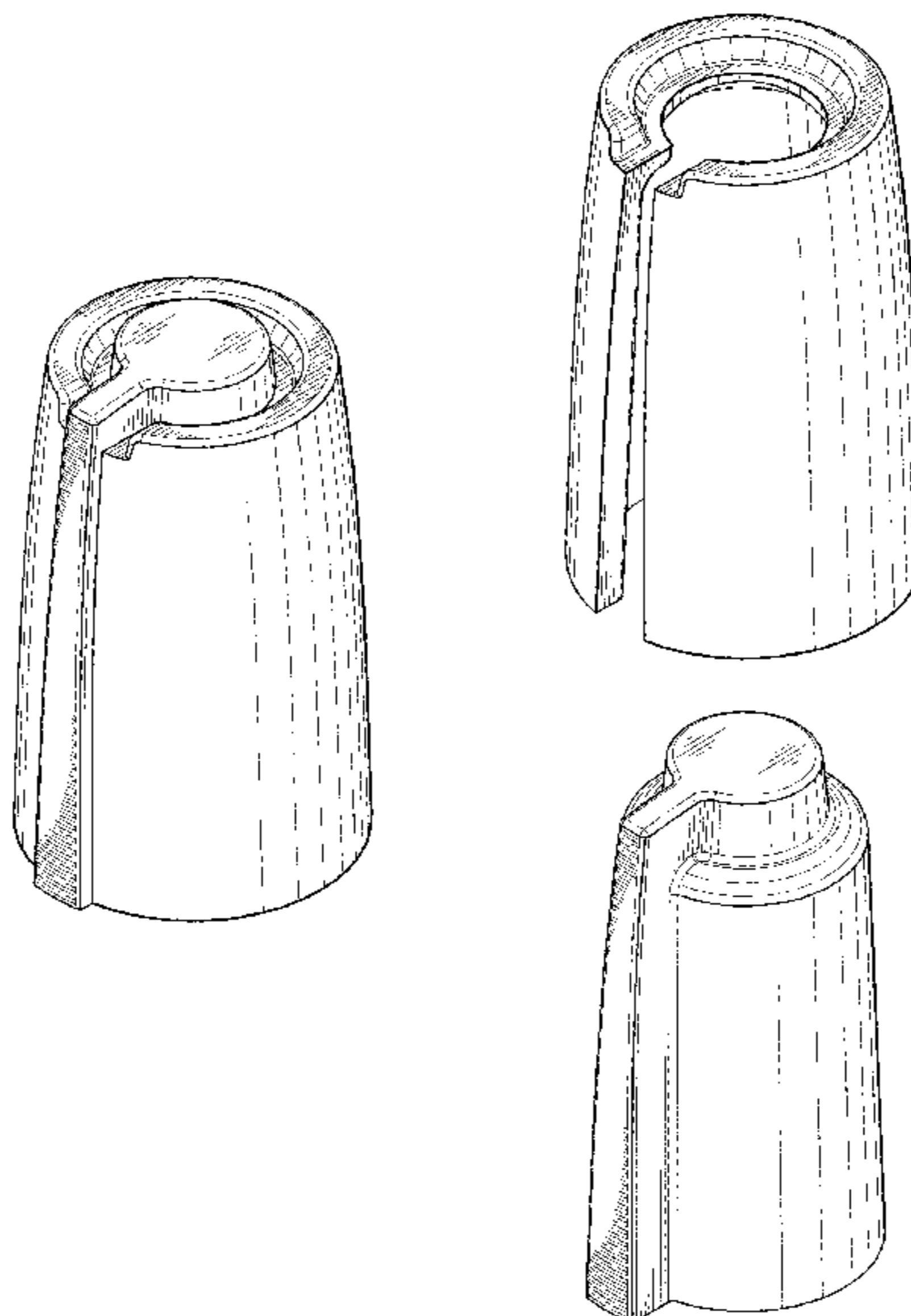

(56)

References Cited

U.S. PATENT DOCUMENTS

D424,056	S	*	5/2000	Ito et al.	D14/162
D444,460	S	*	7/2001	Kitazawa et al.	D14/217
D489,709	S		5/2004	Amiya	
D490,800	S		6/2004	Kitazawa	
D493,162	S		7/2004	Amiya	
D511,767	S	*	11/2005	Ishizaki et al.	D14/217
D518,470	S		4/2006	Takita	
D555,640	S	*	11/2007	Amiya	D14/217
D556,739	S		12/2007	Suzuki	
D573,587	S		7/2008	Amiya	
D578,513	S	*	10/2008	Mazur	D14/217
D610,518	S	*	2/2010	Aglassinger	D12/220
D615,993	S	*	5/2010	Ho	D14/496
D616,867	S	*	6/2010	Ito	D14/217
D616,868	S	*	6/2010	Ito	D14/217
D628,563	S	*	12/2010	Maruska et al.	D14/218
D630,617	S		1/2011	Ayres	
D633,782	S	*	3/2011	Tompkins	D8/382
D654,345	S	*	2/2012	McCune et al.	D8/312
D676,424	S	*	2/2013	Ohashi et al.	D14/217
D677,247	S	*	3/2013	Iijima et al.	D14/217
D680,519	S	*	4/2013	Ito	D14/217

OTHER PUBLICATIONS

“Allen & Heath MixWizard WZ³ 20S: Desk / Rack Mount Stereo Source Console,” Product Guide, 2005, Allen & Heath, Penryn, U.K.,

<<http://www.allen-heath.com/uk/Products/Pages/ProductDetails.aspx?catId=&ProductId=MixWizard320S&SubCatId=>>, 3 pages.
 “Mackie 1604-VLZ3 Professional Compact Mixer,” Specification Sheet, Part No. SW0773 Rev. B, Dec. 2010, Mackie, Woodinville, Wash., <http://www.mackie.com/products/1604vlz3/pdf/1604VLZ3_SS.pdf>, 7 pages.
 “PV@6 USB Mixing Console,” Specifications, Peavey, Meridian, Miss., <<http://www.peavy.com>>, May 2011, 4 pages.
 “Samson MDR624 Maximum Dynamic Range Six Channel Mixer,” Specification Sheet, May 2006, Samson Technologies, Hauppauge, N.Y., <<http://www.samsontech.com/samson/products/mixers/mdr-series/mdr624/>> [retrieved Jul. 22, 2013], 1 page.
 “Soundcraft EFX8 8-Channel Mixer With 24-Bit Lexicon Digita,” photograph, Soundcraft by Harman, 5 pages.
 “Xenyx X1204USB Premium 12-Input 2/2-Bus Mixer,” photograph, Behringer, <<http://www.behringer.com/EN/Products/X1204USB.aspx>> [retrieved Jul. 22, 2013], 1 page.
 “Yamaha MG102C Stereo Mixer,” photograph, Yamaha Corporation, <http://usa.yamaha.com/products/live_sound/mixers/analog-mixers/mg_series_c_models/mg102c/?mode=model> [retrieved Jul. 22, 2013], 1 page.
 “Yamaha MGP12X: 12-Channel Premium Mixing Console,” photograph, Yamaha Corporation, <http://usa.yamaha.com/products/live_sound/mixers/analog-mixers/mgp/mgp12x/?mode=model> [retrieved Jul. 22, 2013], 1 page.
 “Alto ZMX862: 6-Channel Compact Mixer,” photograph, Alto Professional, 1 page.

* cited by examiner

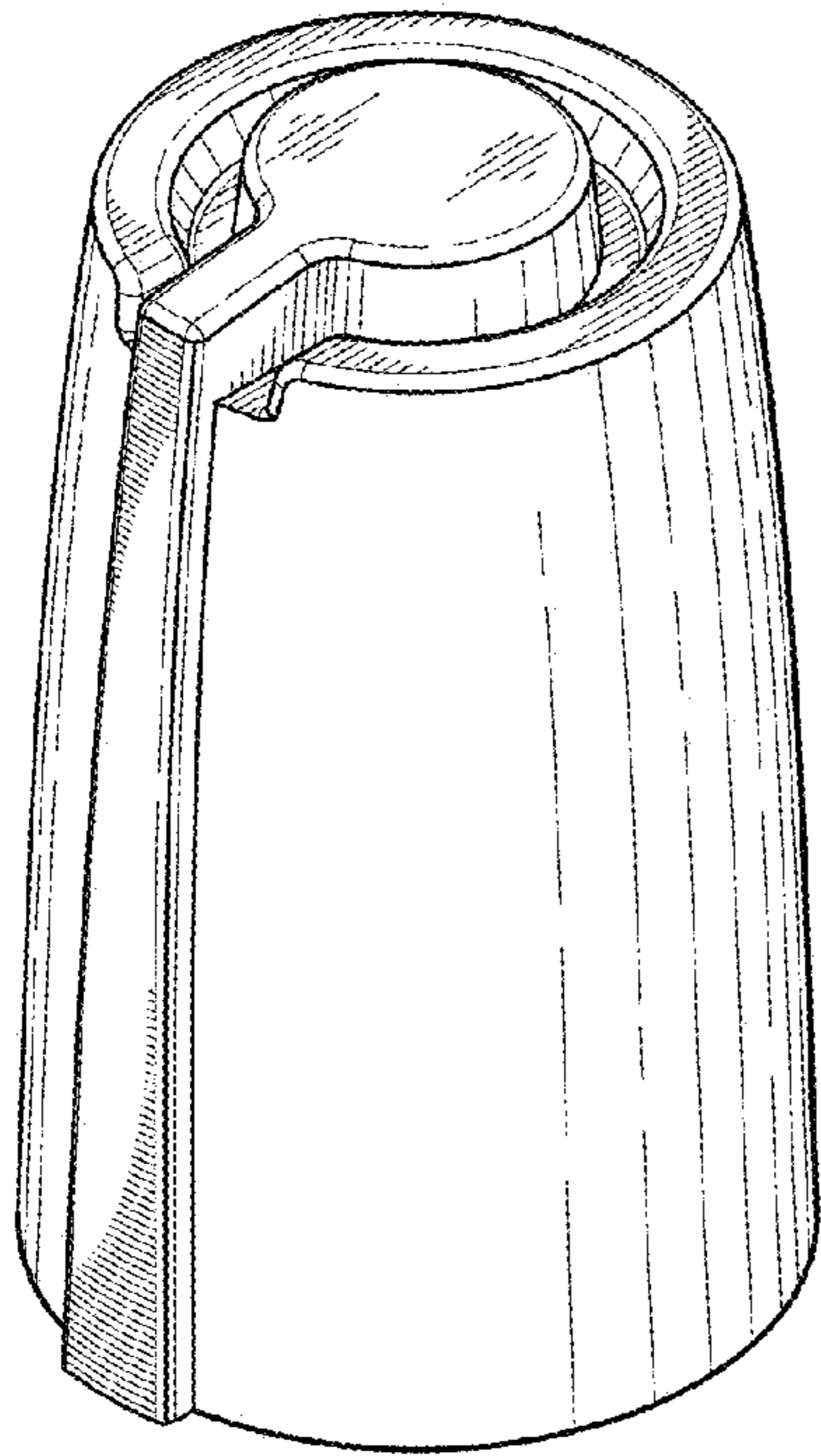

Fig. 1.

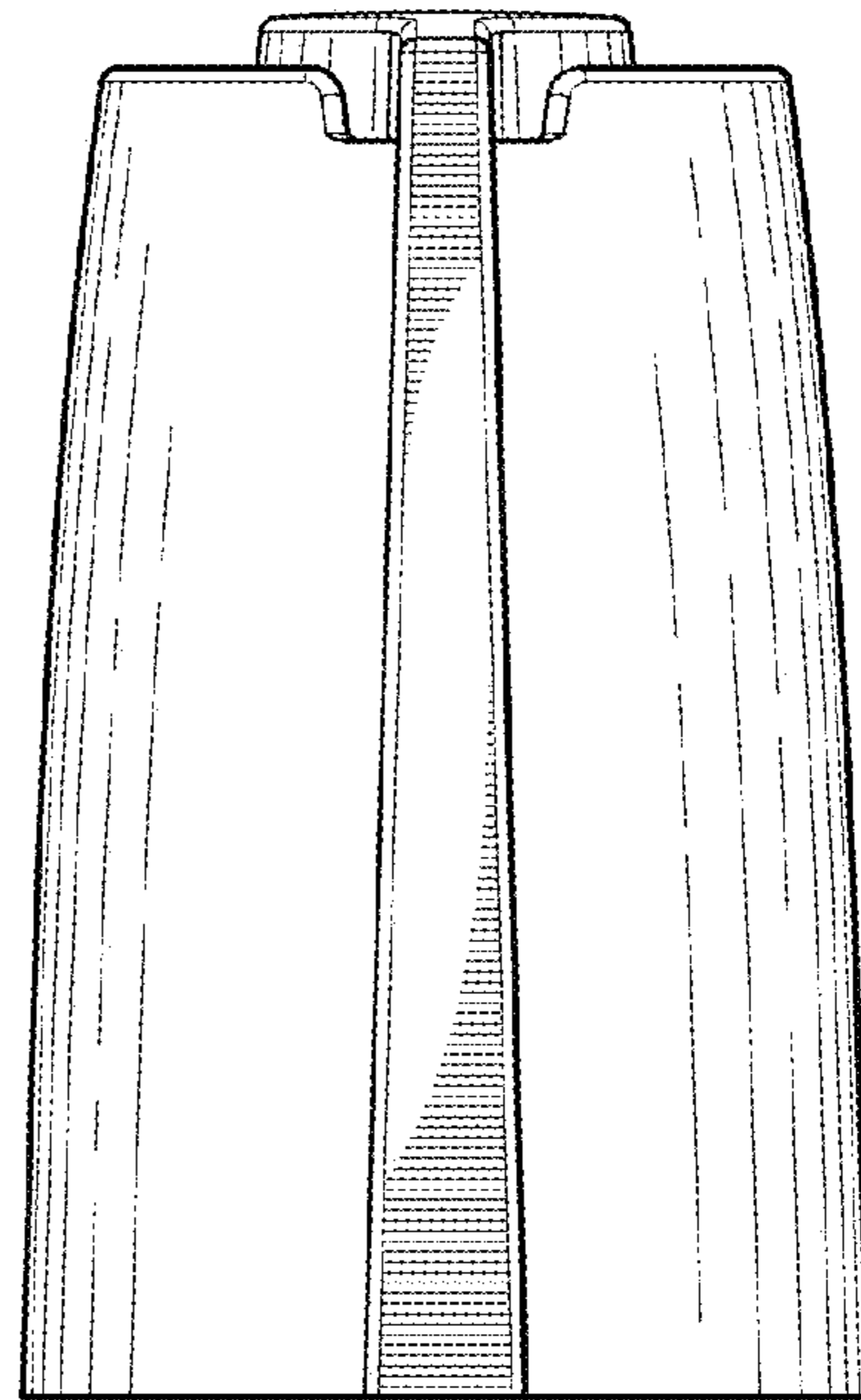

Fig. 2.

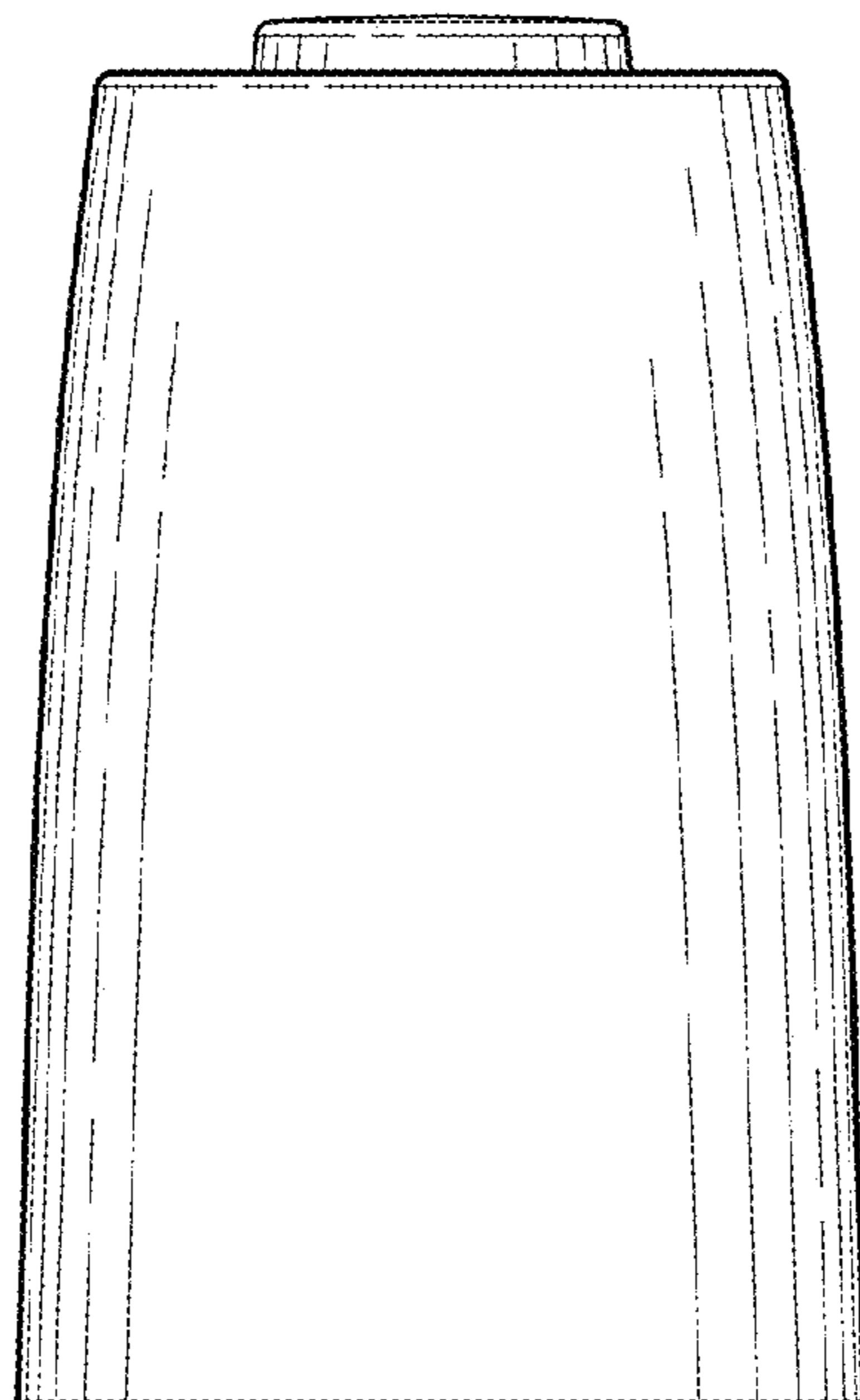

Fig. 3.

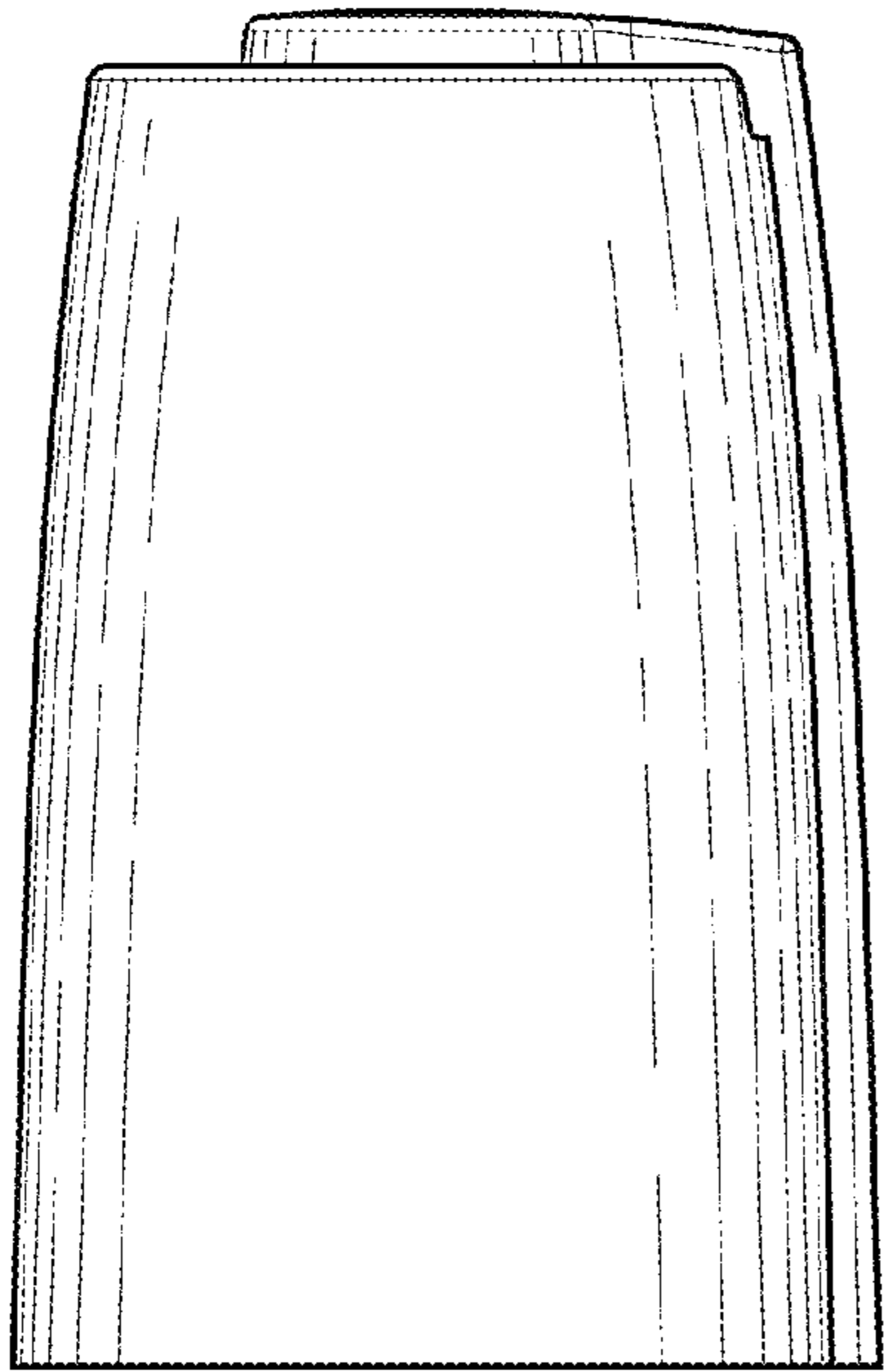

Fig. 4.

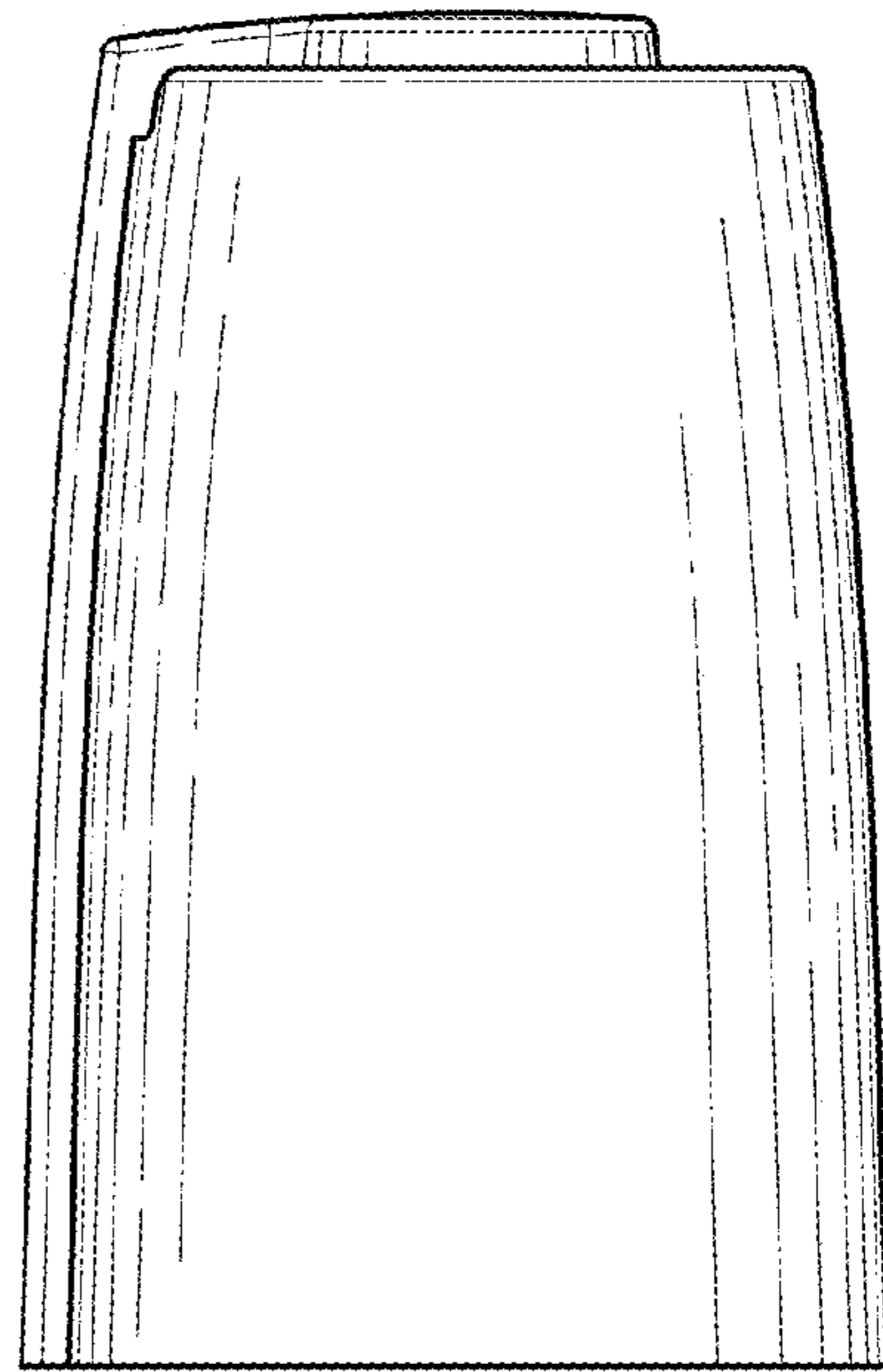

Fig. 5.

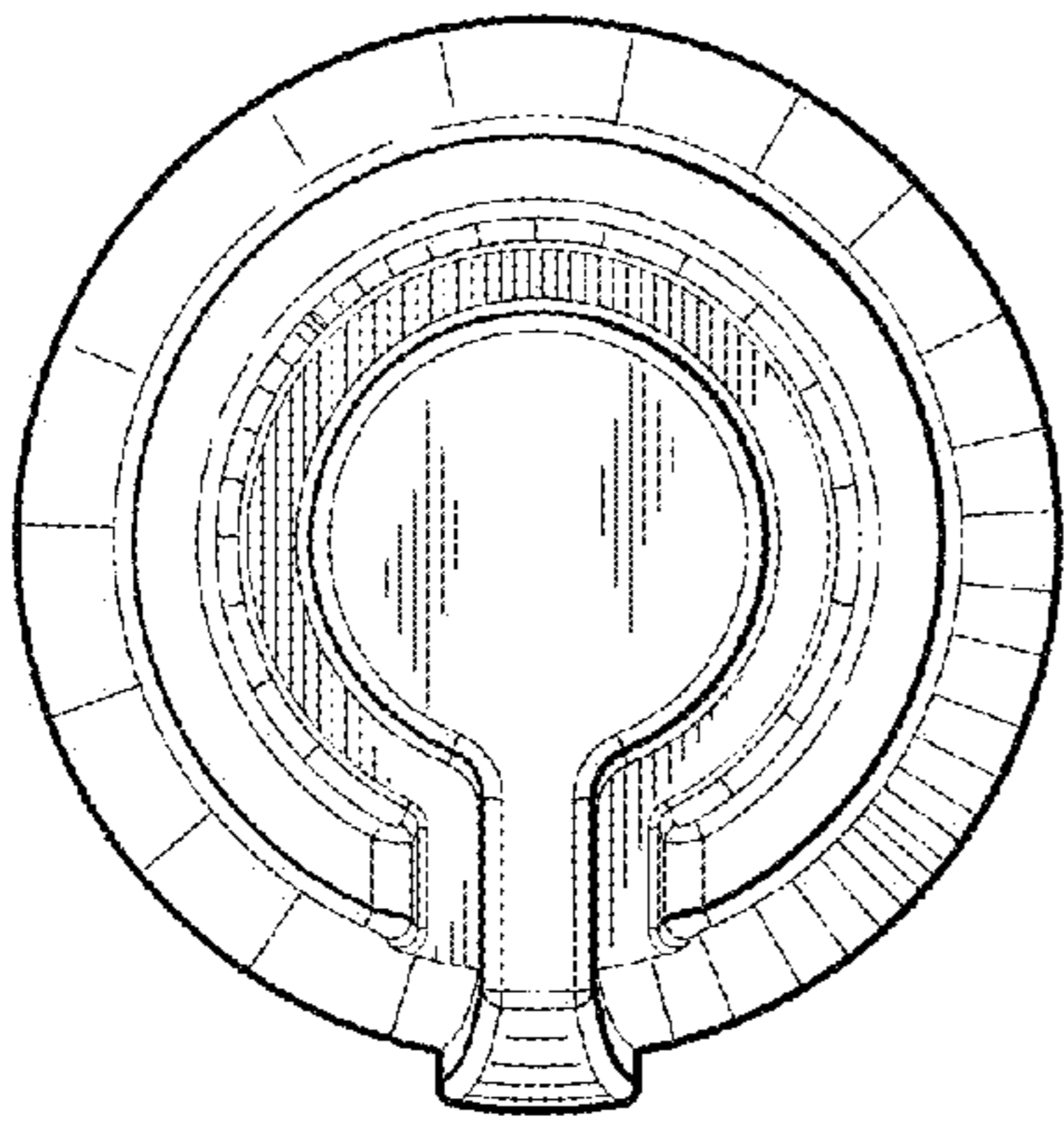

Fig. 6.

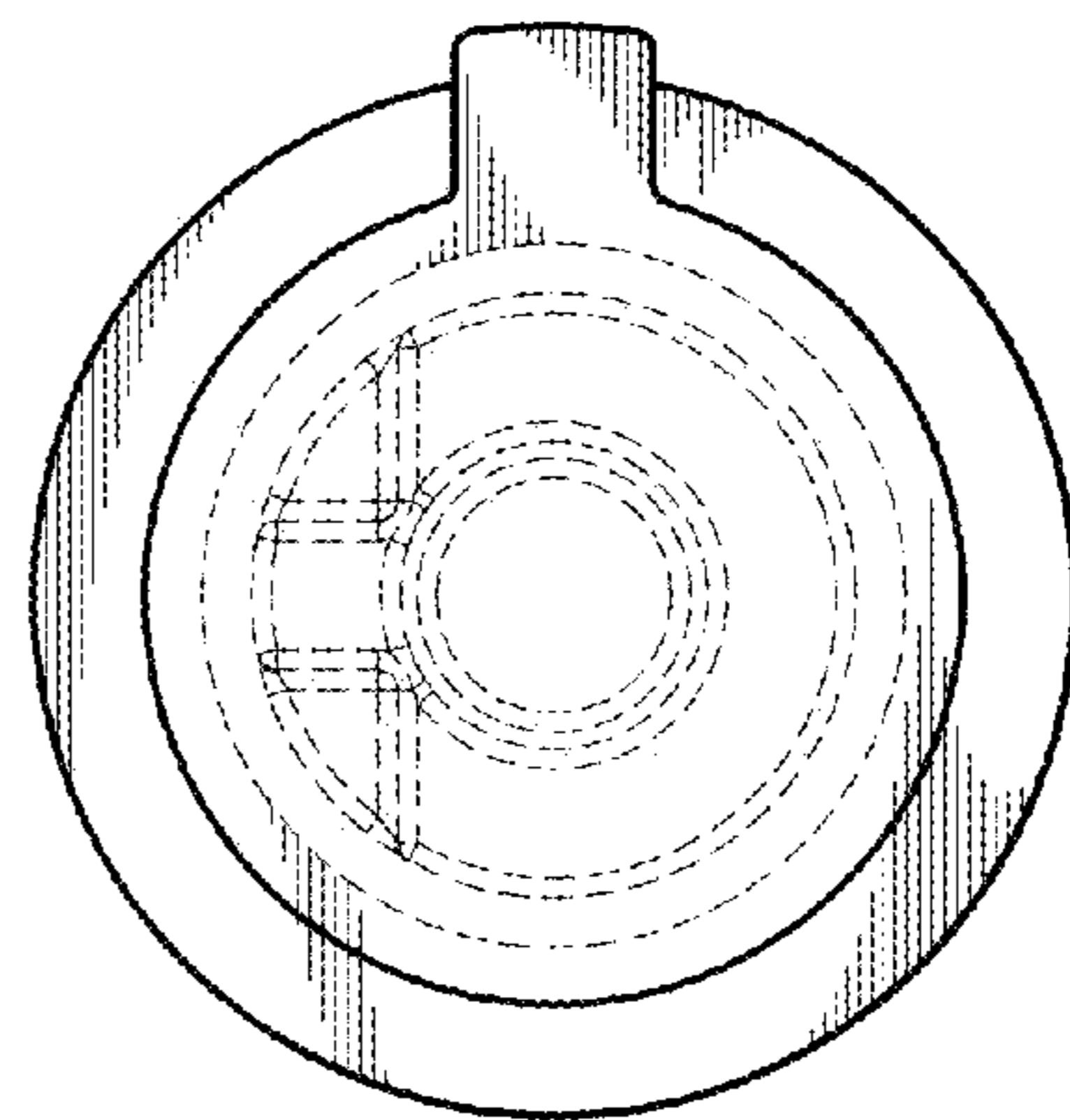

Fig. 7.

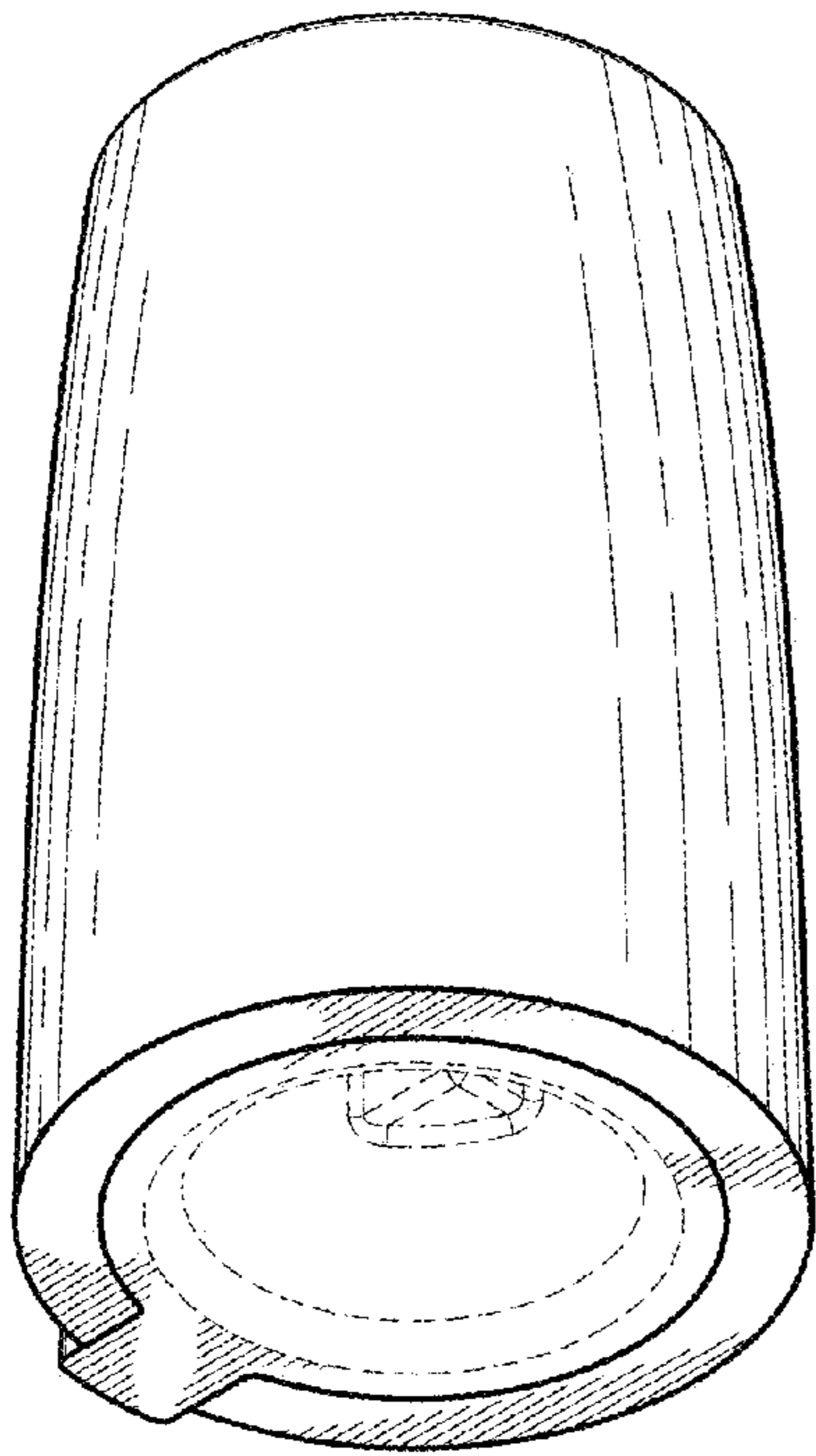

Fig. 8.

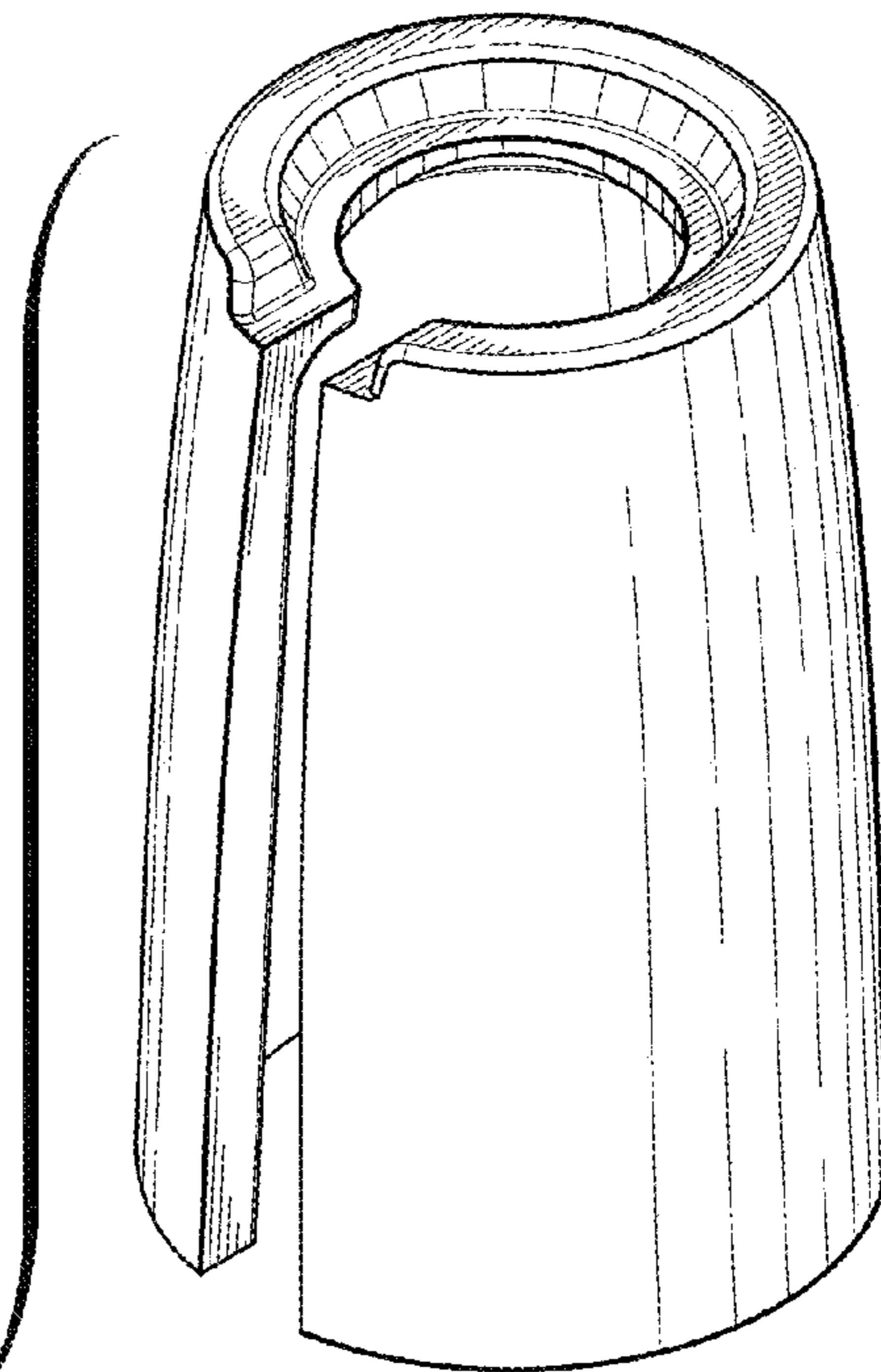
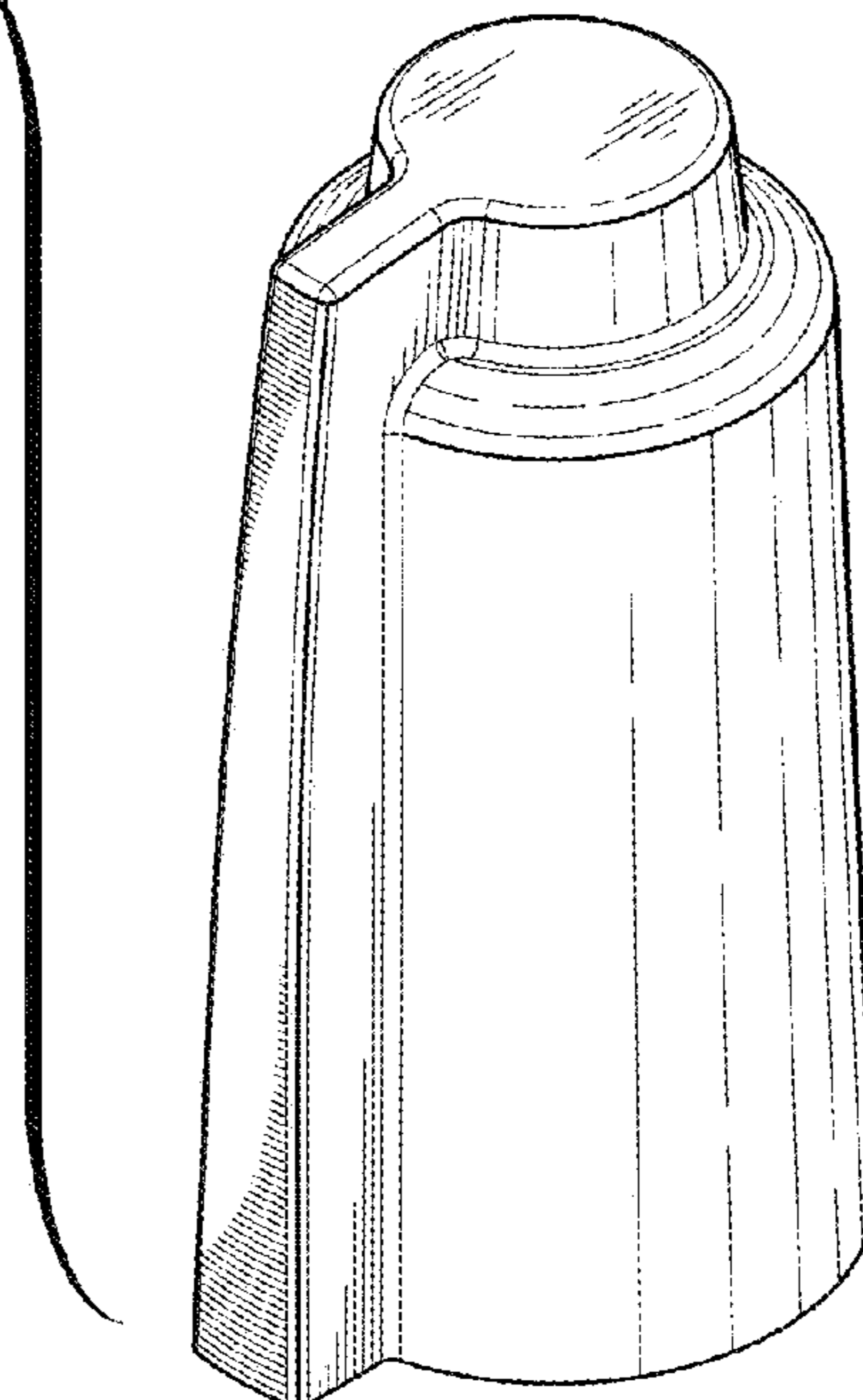

Fig. 9.



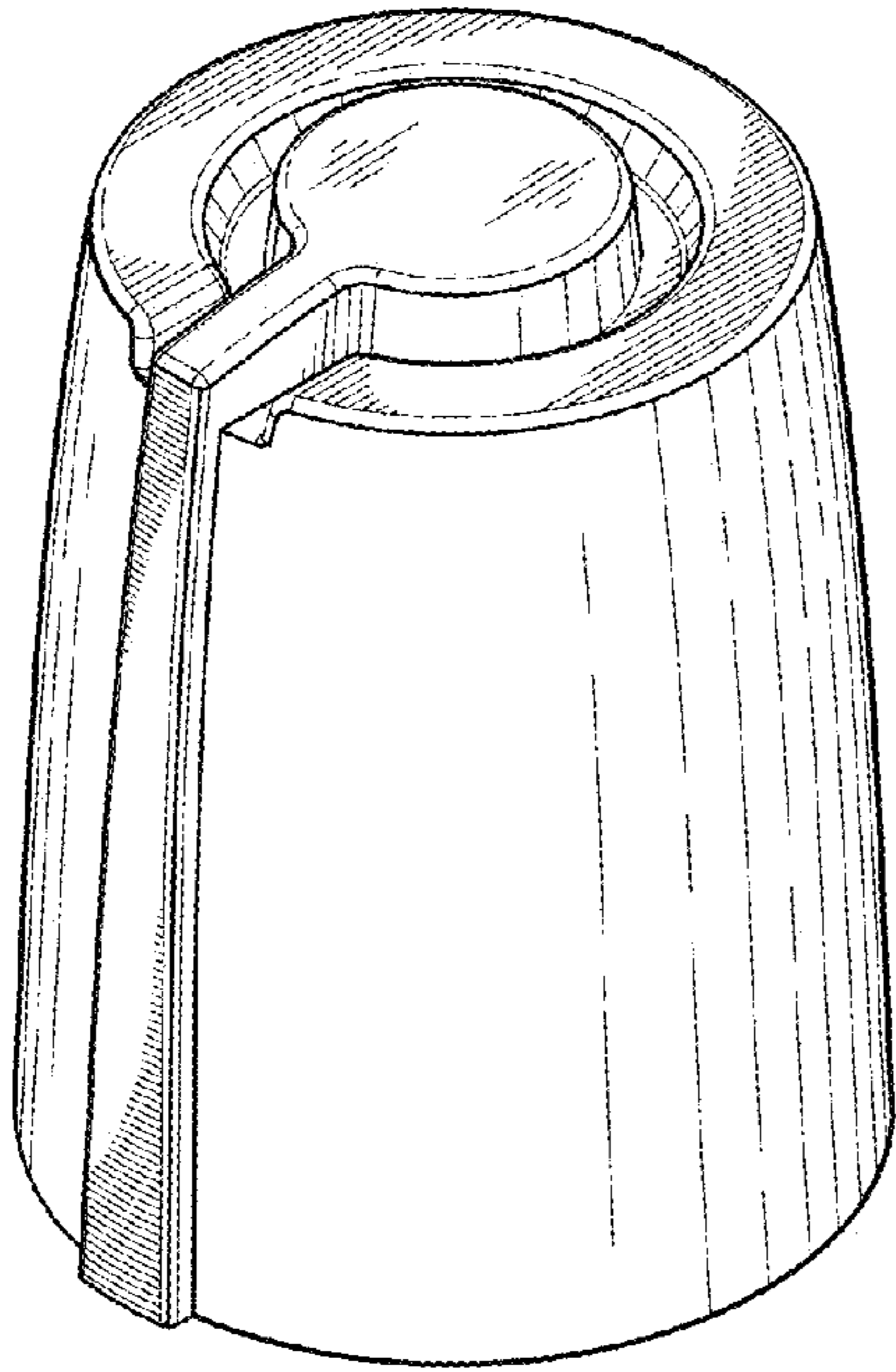

Fig. 10.

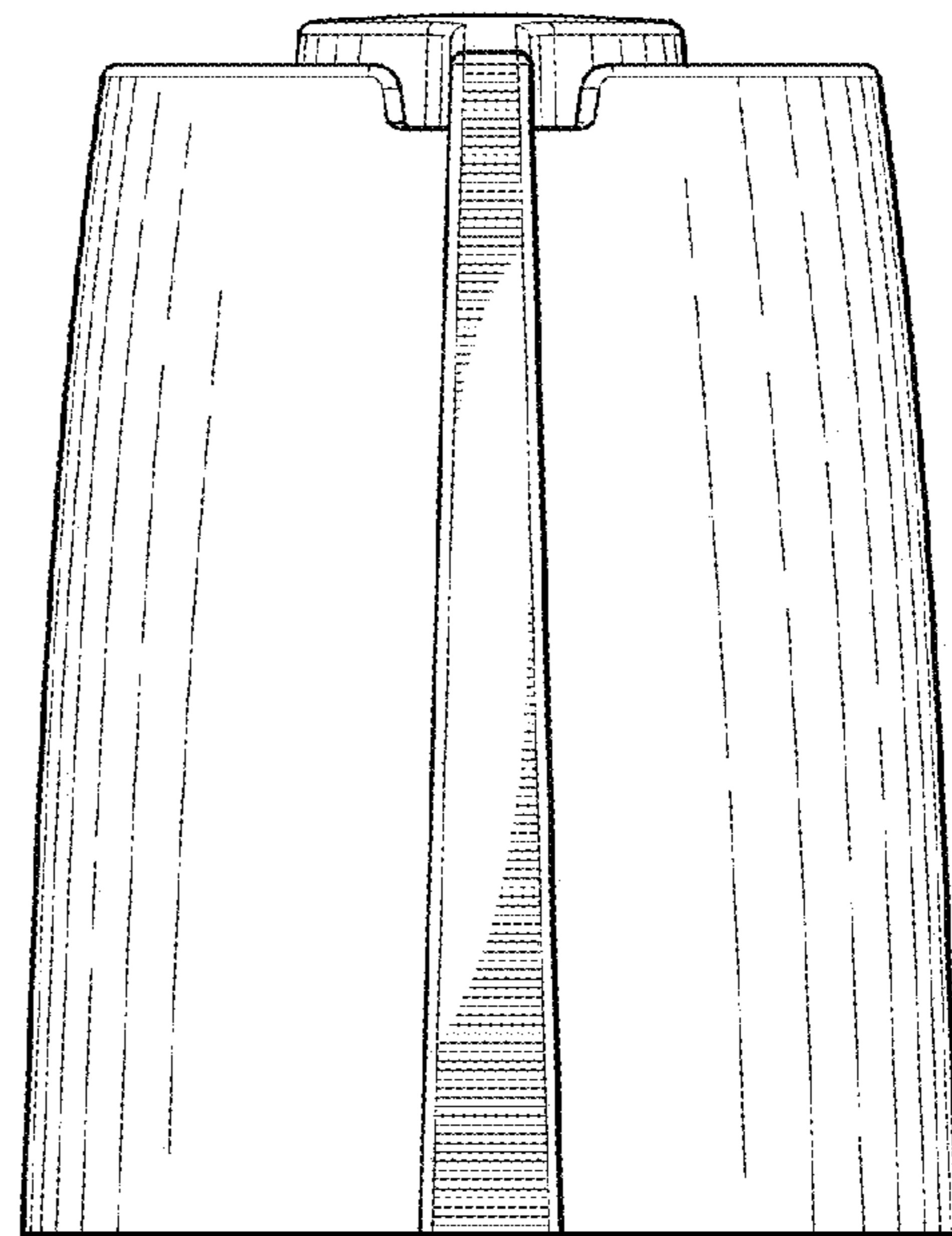

Fig. 11.

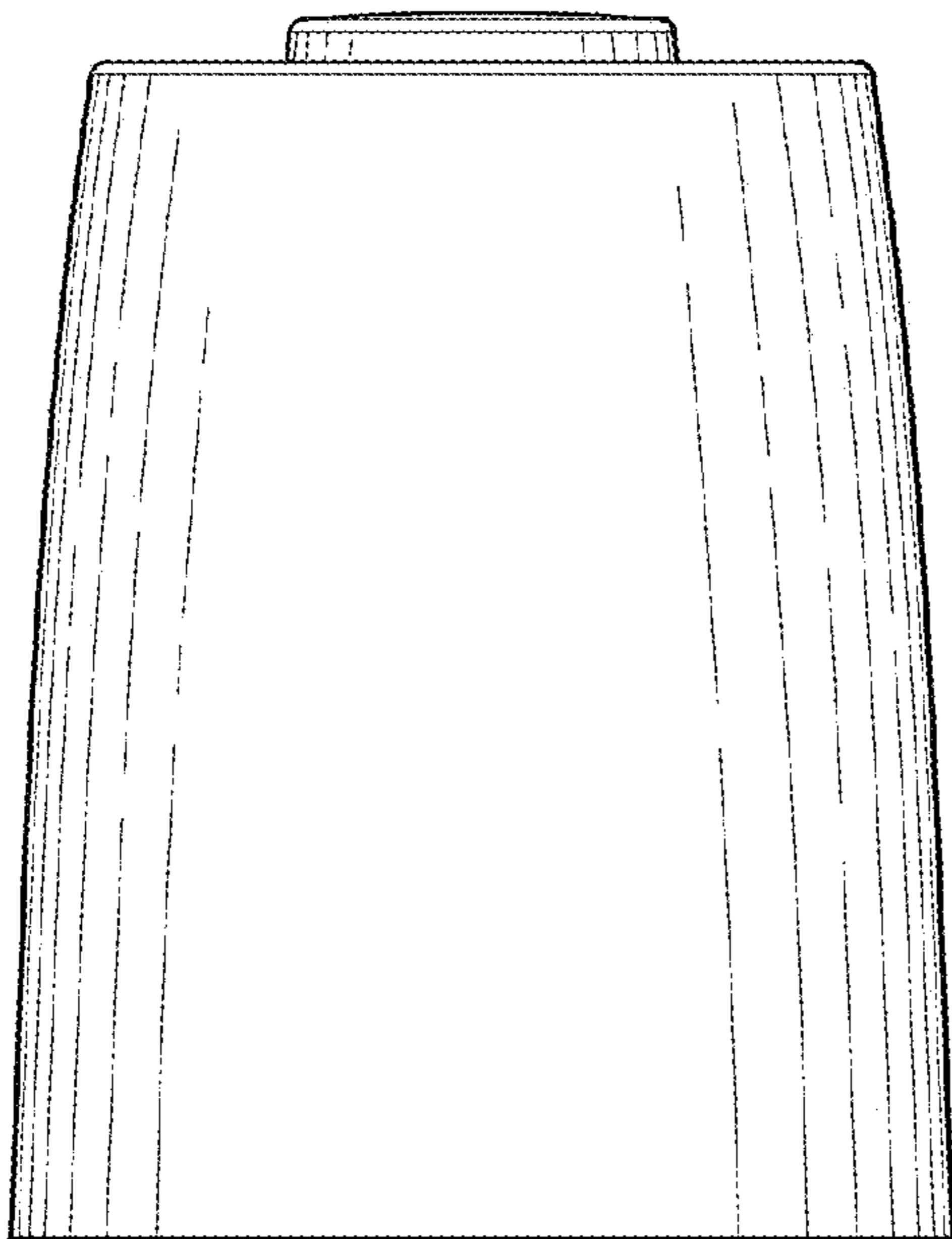

Fig. 12.

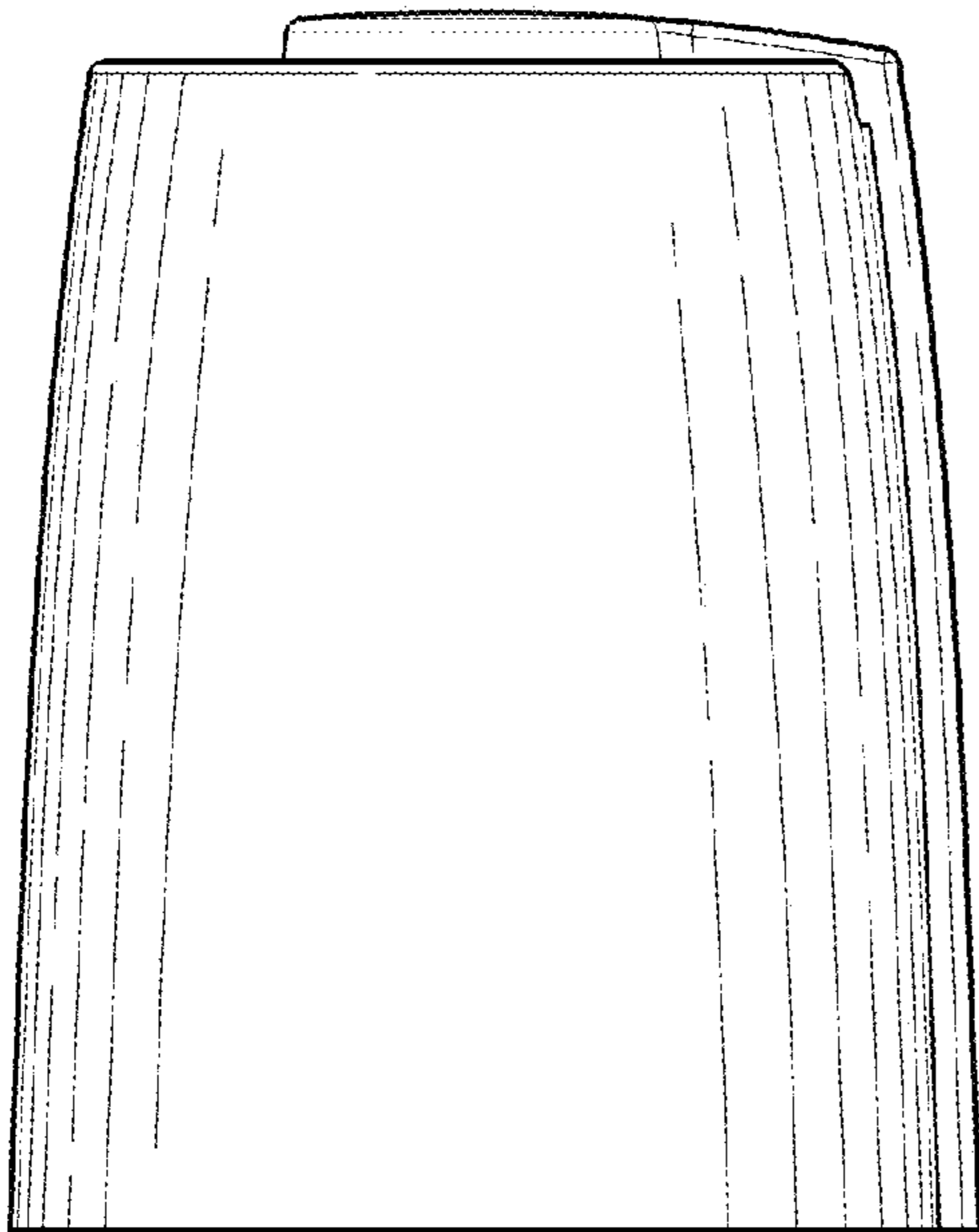

Fig. 13.

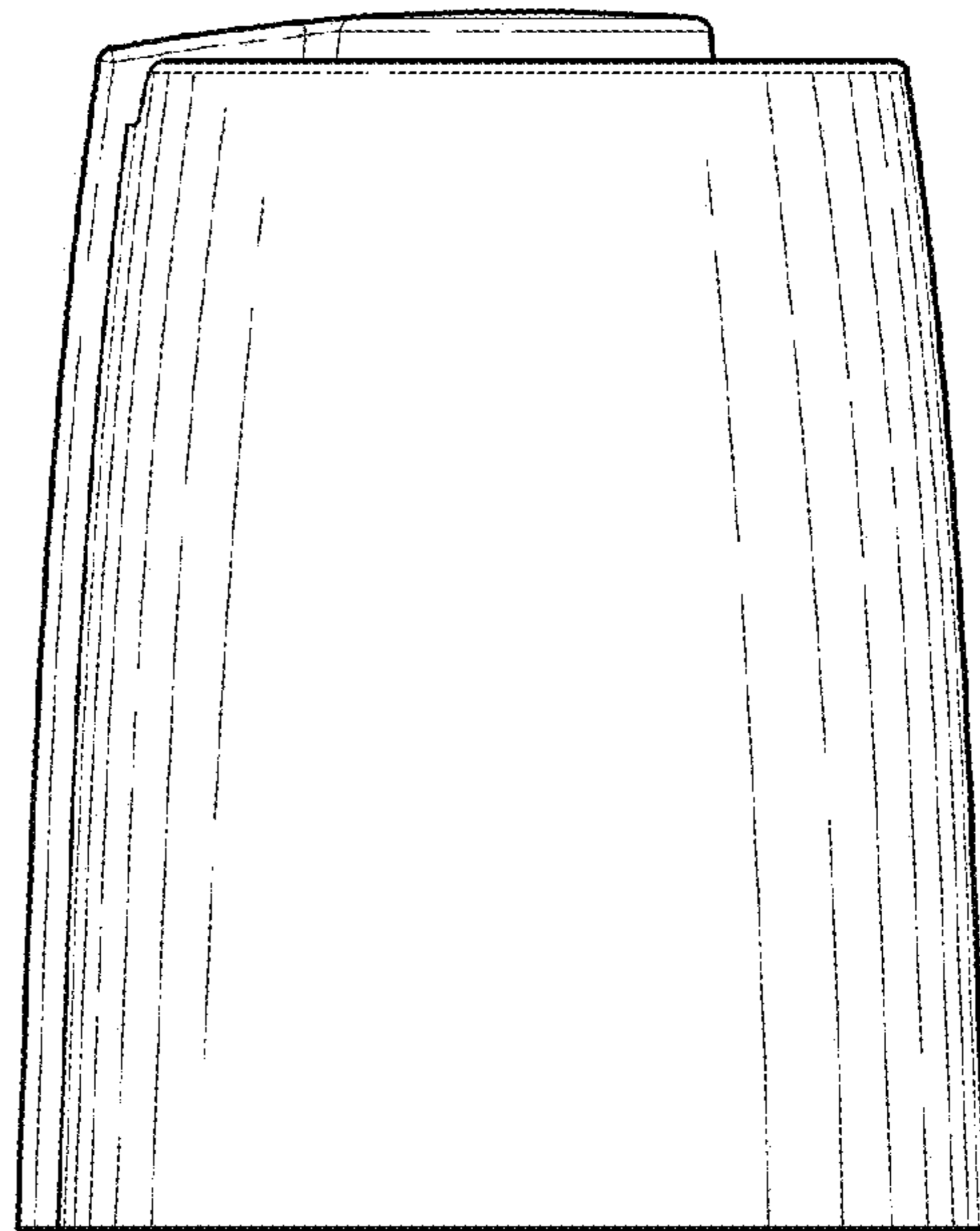

Fig. 14.

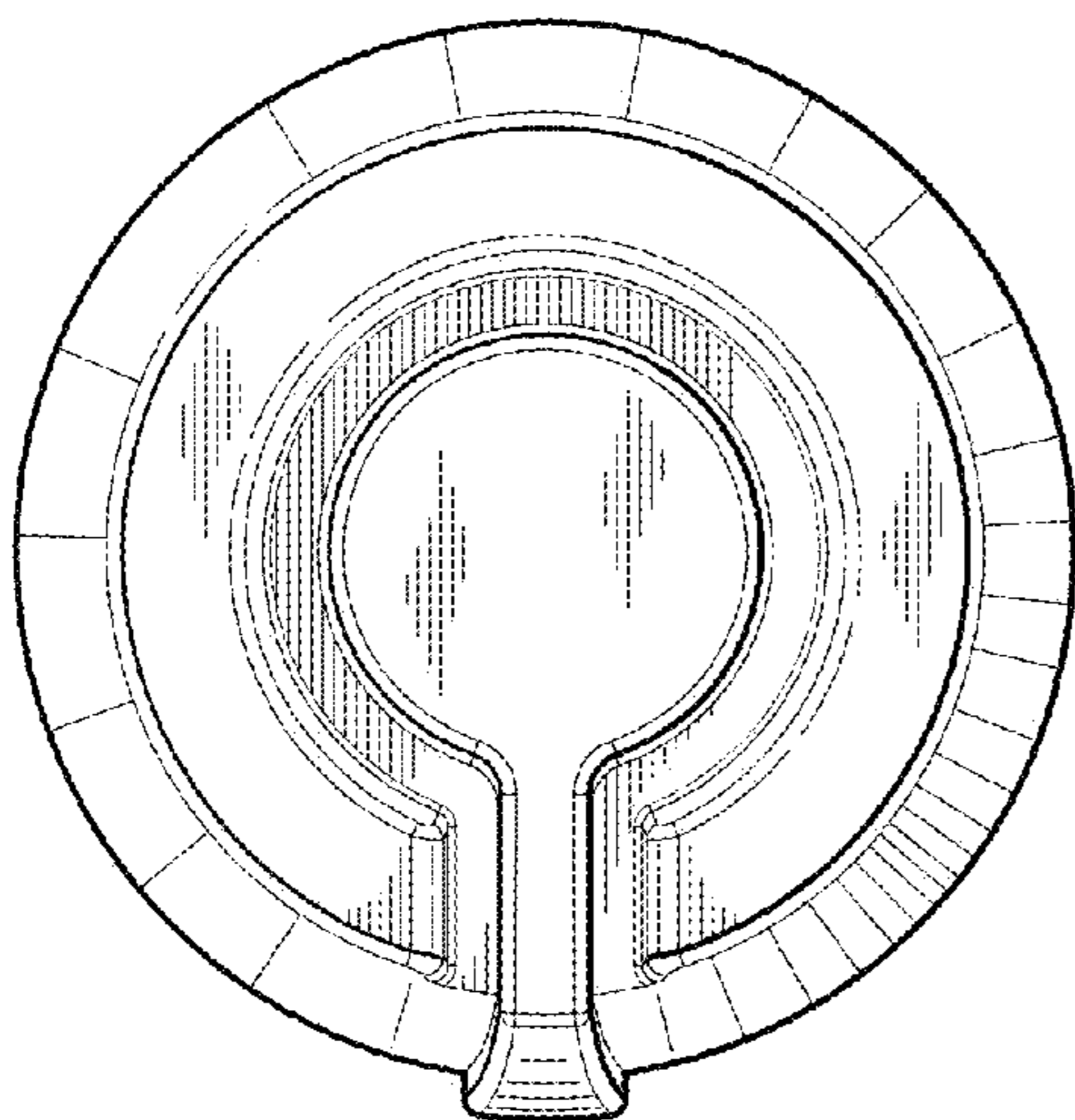

Fig. 15.

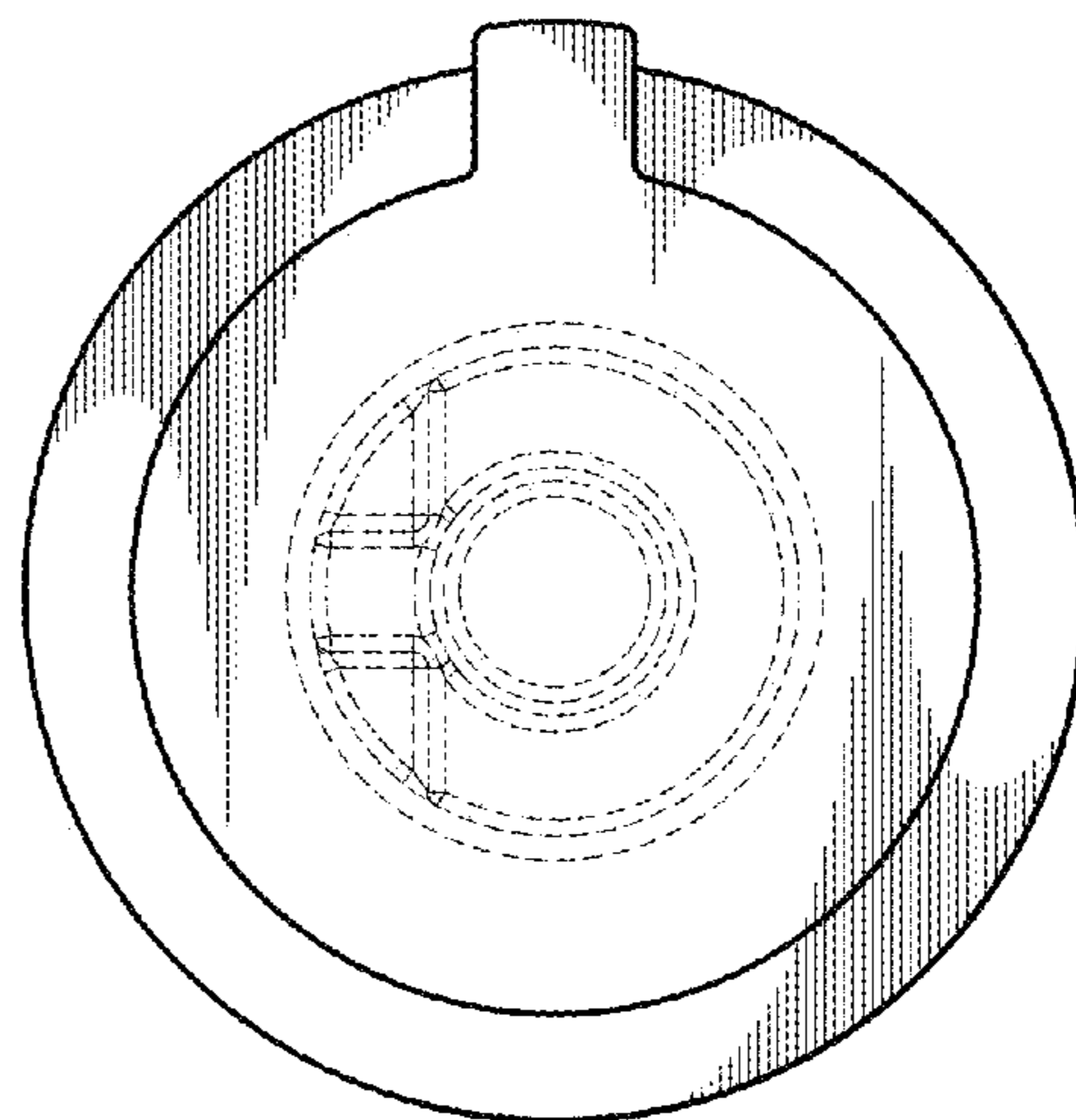

Fig. 16.

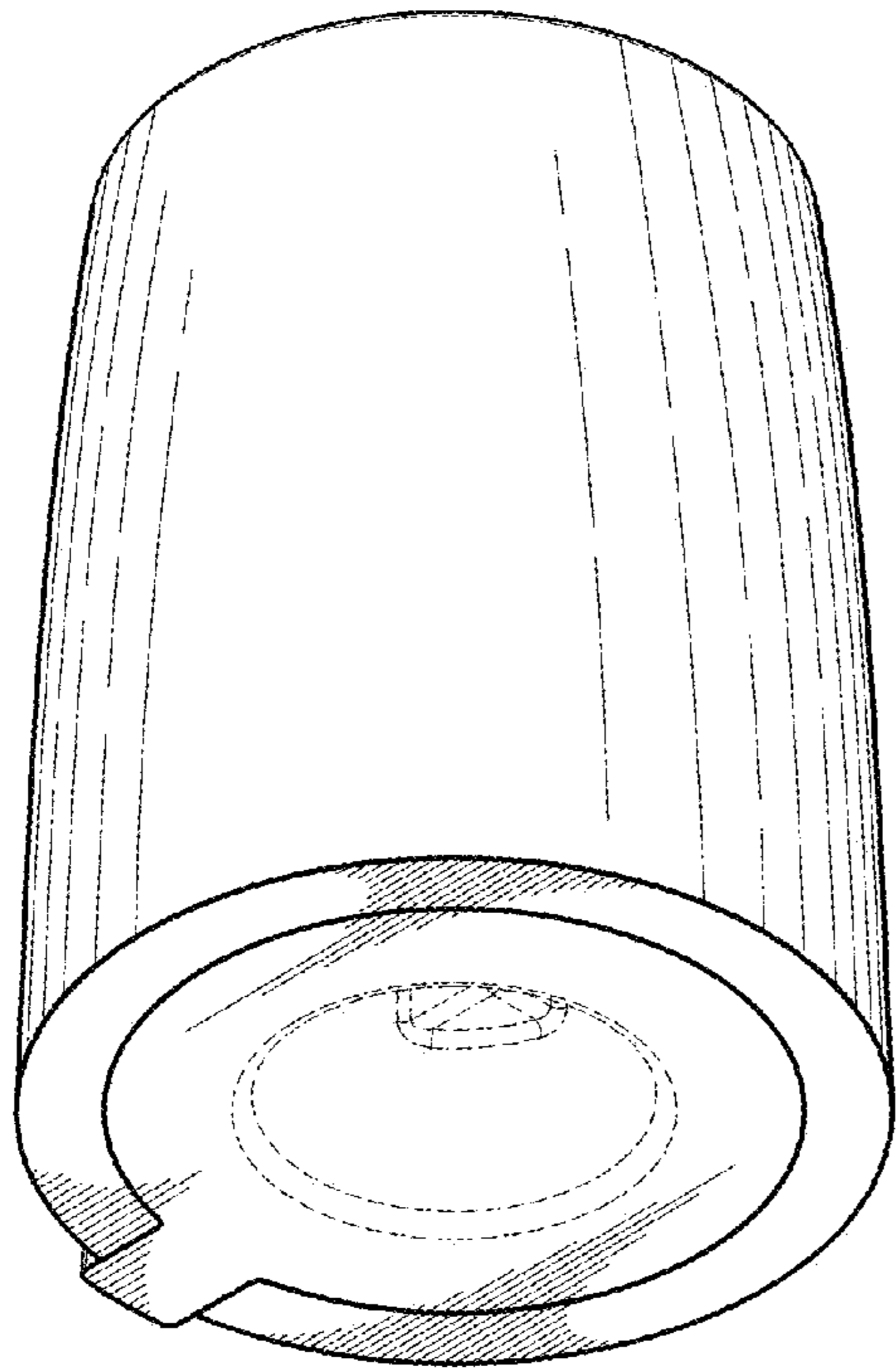

Fig. 17.

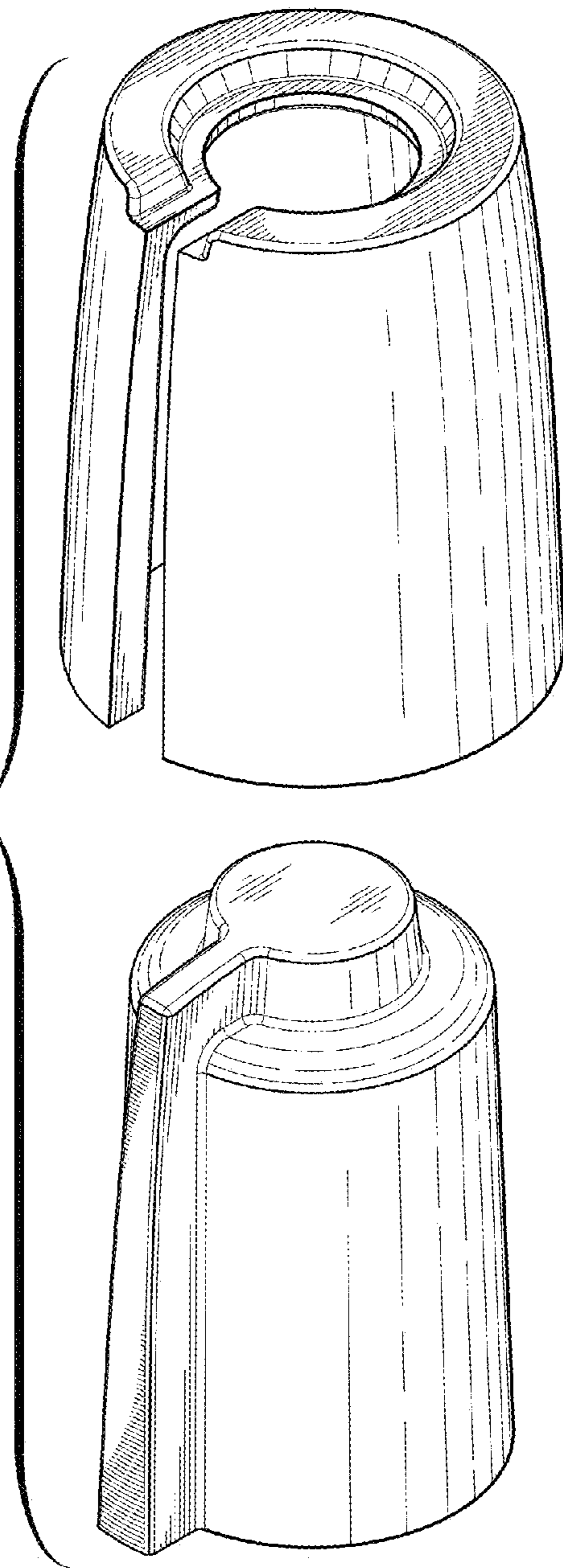

Fig. 18.