



US00D726121S

(12) **United States Design Patent**
Nook et al.

(10) **Patent No.:** **US D726,121 S**
(45) **Date of Patent:** **** Apr. 7, 2015**

- (54) **ELECTRICAL CONNECTOR**
- (71) Applicant: **The Noco Company**, Glenwillow, OH (US)
- (72) Inventors: **Jonathan Lewis Nook**, Gates Mills, OH (US); **William Knight Nook, Sr.**, Shaker Heights, OH (US); **James Richard Stanfield**, Peoria, AZ (US); **Derek Michael Underhill**, Tempe, AZ (US)
- (73) Assignee: **The Noco Company**, Glenwillow, OH (US)

5,342,222 A *	8/1994	Tanaka	439/708
D361,745 S *	8/1995	Geroux et al.	D13/120
D411,983 S *	7/1999	Awbrey	D13/148
D444,772 S *	7/2001	Milan	D13/154
D465,205 S *	11/2002	Orpilla et al.	D13/154
D473,194 S *	4/2003	Lee	D13/154
D542,224 S *	5/2007	Victor	D13/154
D543,154 S *	5/2007	Suckle et al.	D13/154
D567,184 S *	4/2008	Victor	D13/156
D573,536 S *	7/2008	Hariharsan et al.	D13/133
D604,251 S *	11/2009	Hwang	D13/154
8,491,341 B2 *	7/2013	Bower et al.	439/638
D708,140 S *	7/2014	Nook et al.	D13/133

* cited by examiner

(**) Term: **14 Years**

Primary Examiner — Derrick Holland
Assistant Examiner — Jennifer O King

(21) Appl. No.: **29/486,666**

(74) *Attorney, Agent, or Firm* — Vorys, Sater, Seymour and Pease LLP; William L. Klima

(22) Filed: **Apr. 1, 2014**

(51) **LOC (10) Cl.** **13-03**

(52) **U.S. Cl.**
USPC **D13/148; D13/120**

(58) **Field of Classification Search**
USPC D13/107, 110, 120, 133, 146, 148, 149, D13/184, 199, 156; 439/248, 258, 274, 447, 439/603, 660, 607.01, 677, 680, 682, 686, 439/755; 174/74 R, 84 C
See application file for complete search history.

(56) **References Cited**

U.S. PATENT DOCUMENTS

3,794,957 A *	2/1974	Winkler	439/295
3,895,851 A *	7/1975	Bolton et al.	439/387

(57) **CLAIM**

The ornamental design for an electrical connector, as shown and described.

DESCRIPTION

FIG. 1 is a perspective view for a electrical connector;
FIG. 2 is a front elevational view thereof;
FIG. 3 is a rear elevational view thereof;
FIG. 4 is a left-side view thereof;
FIG. 5 is a right-side view thereof;
FIG. 6 is a top plan view thereof; and,
FIG. 7 is a bottom plan view thereof.

1 Claim, 5 Drawing Sheets

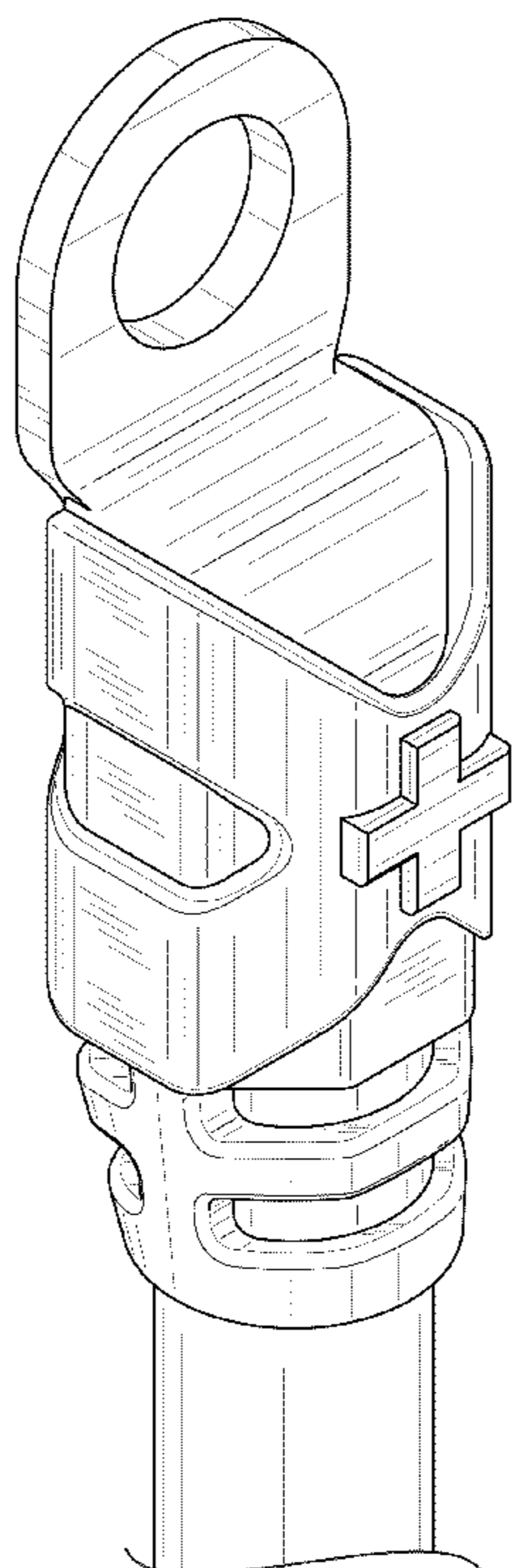

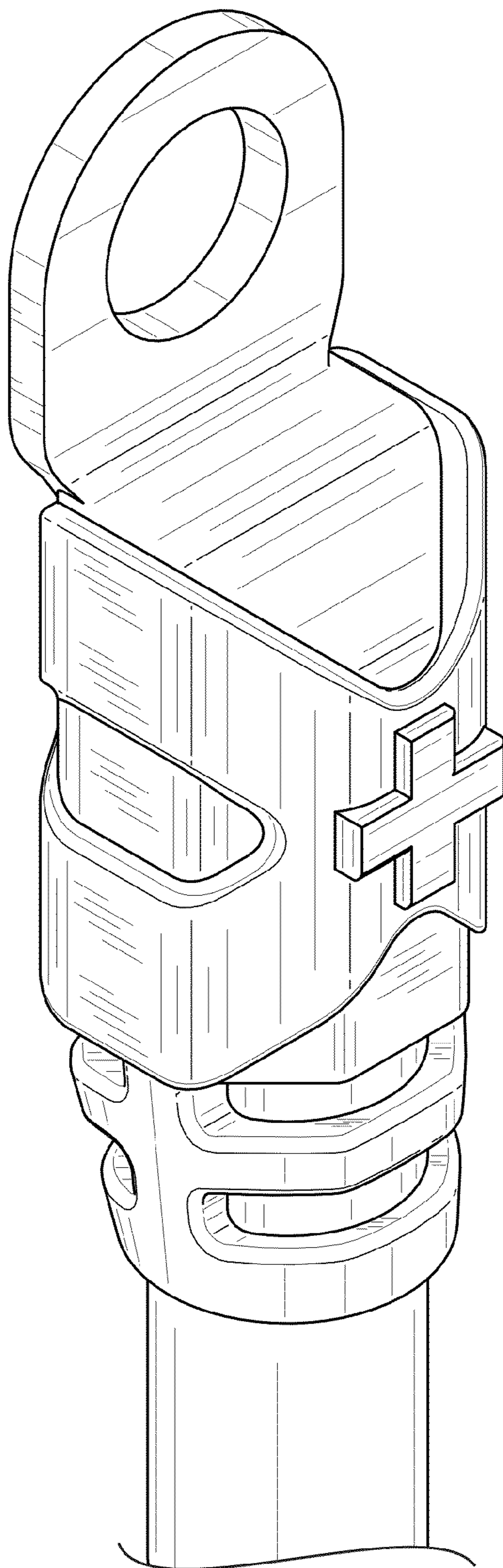

FIG. 1

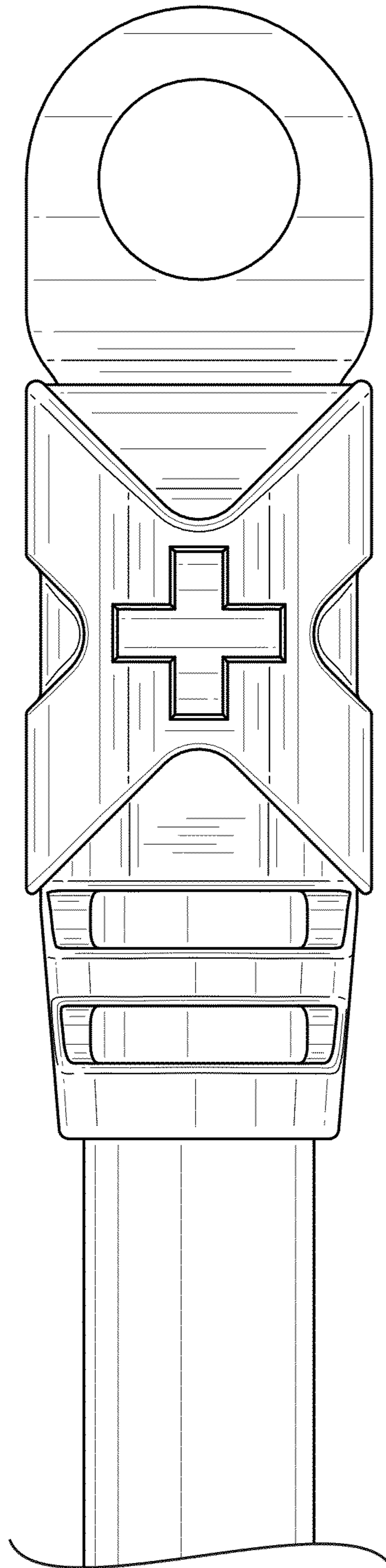

FIG. 2

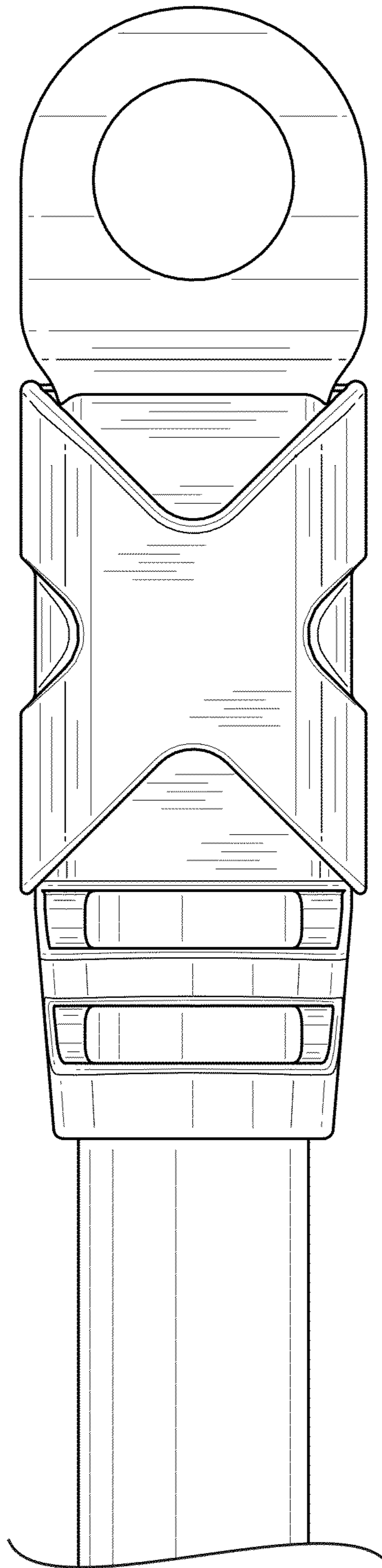

FIG. 3

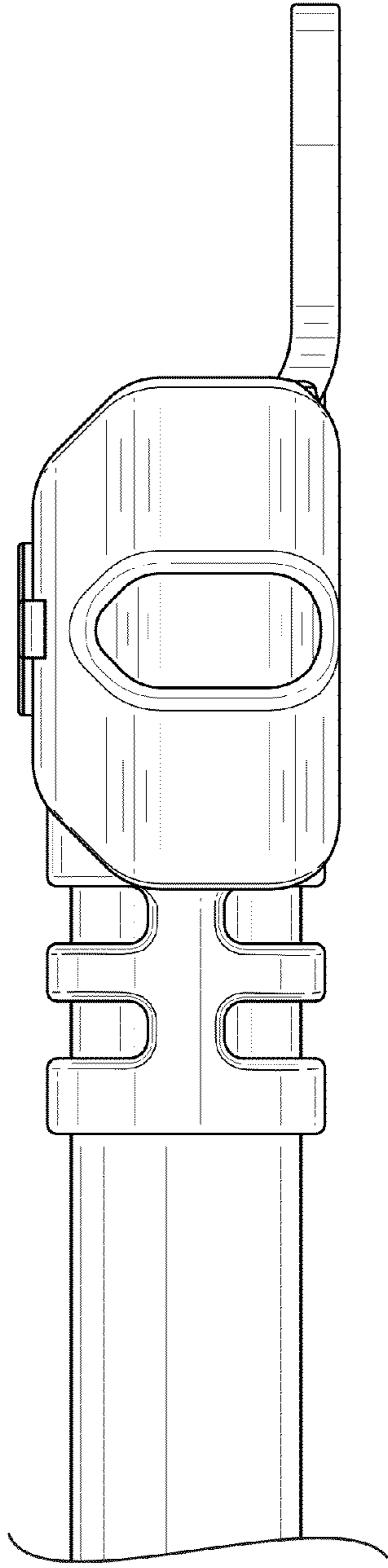

FIG. 4

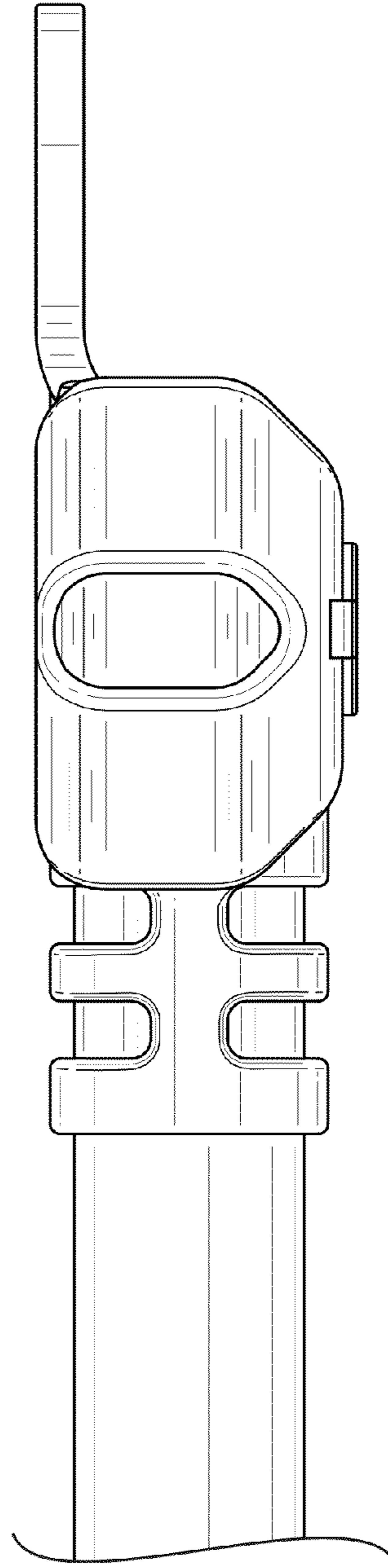

FIG. 5

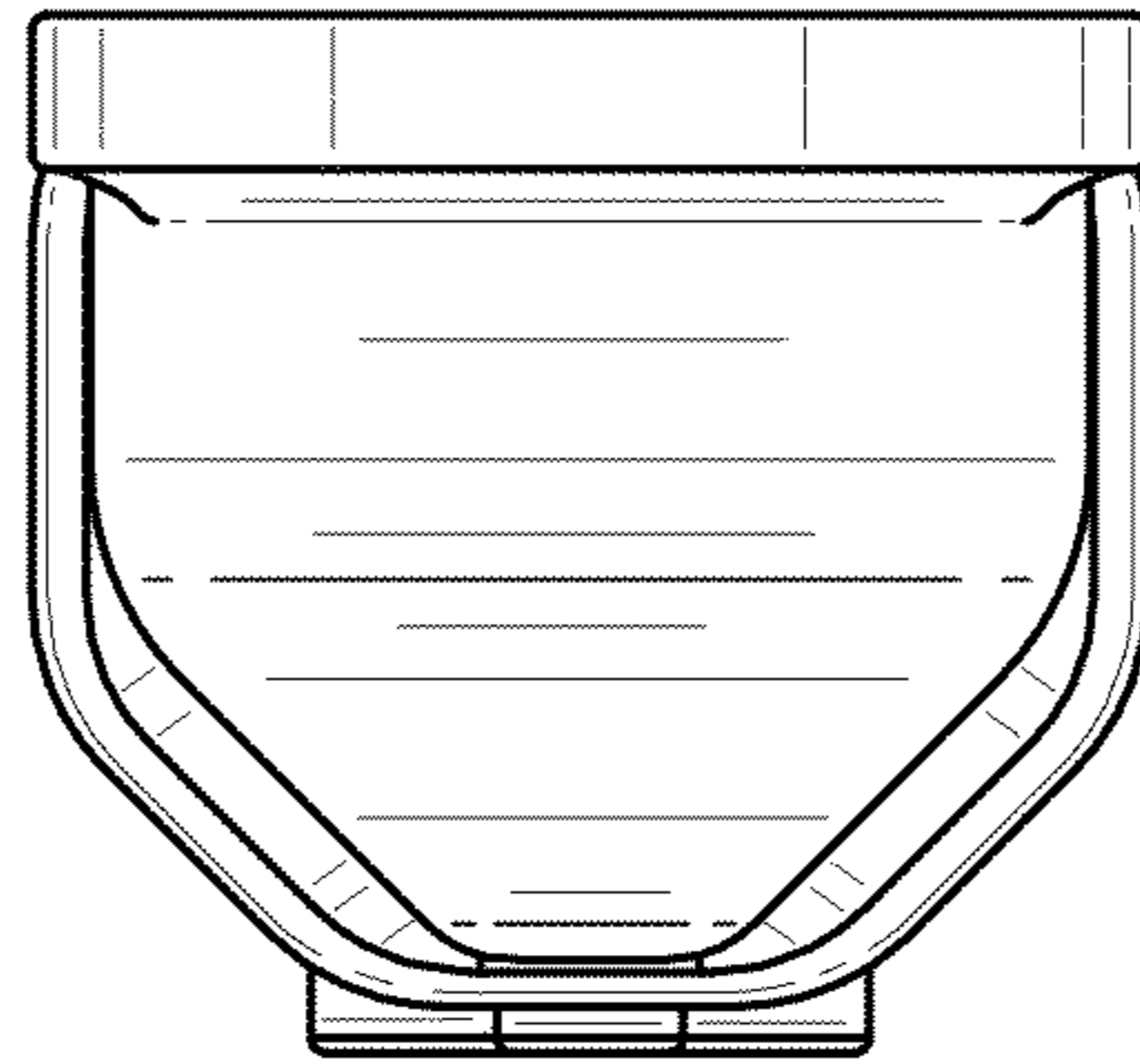

FIG. 6

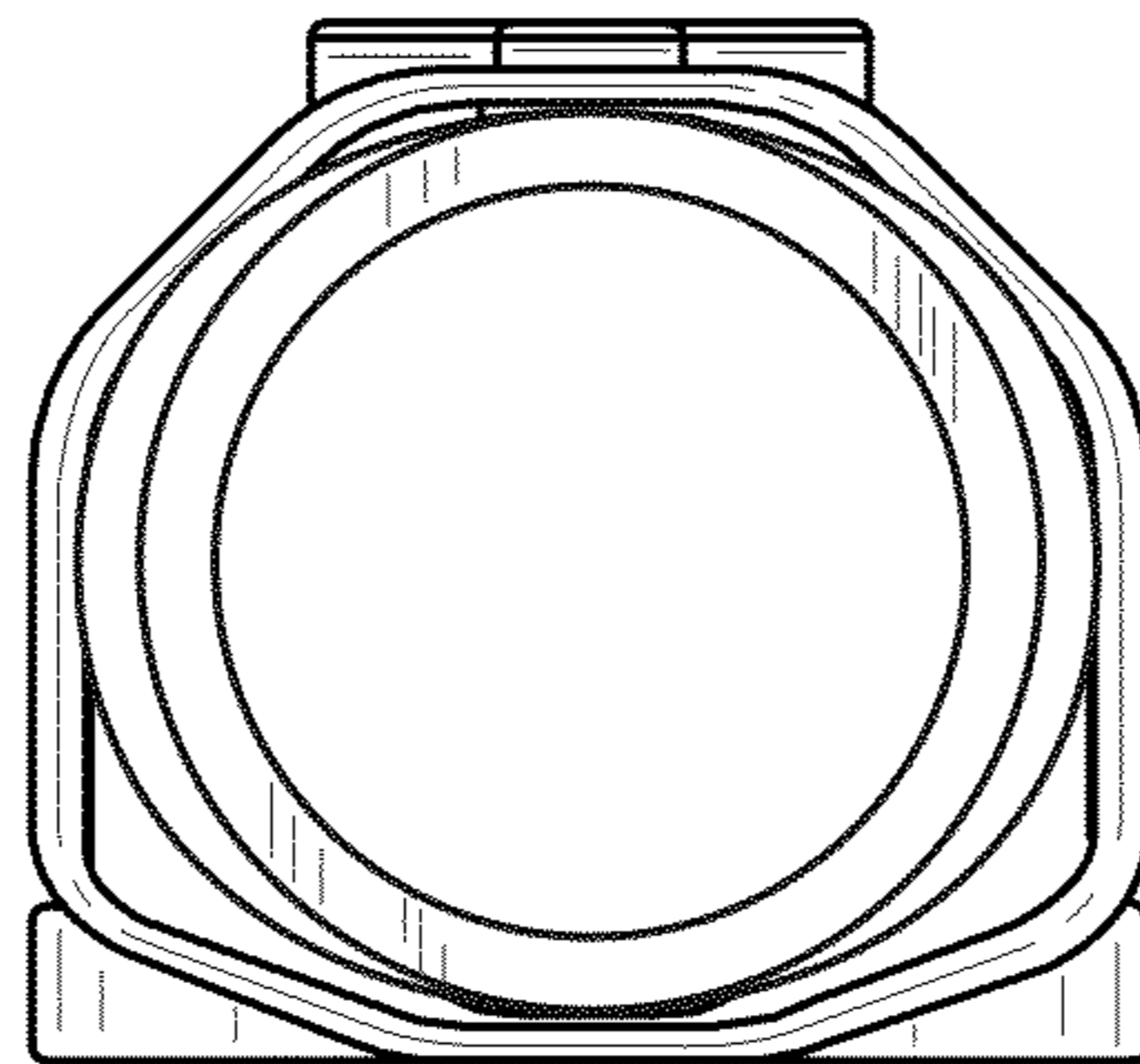

FIG. 7