



US00D725644S

(12) **United States Design Patent**  
**Schulter**

(10) **Patent No.:** **US D725,644 S**  
(45) **Date of Patent:** **\*\* Mar. 31, 2015**

(54) **QUICK RELEASE APPARATUS FOR A PORTABLE DEVICE**

(71) Applicant: **Michael Schulter**, Spring, TX (US)

(72) Inventor: **Michael Schulter**, Spring, TX (US)

(\*\*) Term: **14 Years**

(21) Appl. No.: **29/488,946**

(22) Filed: **Apr. 24, 2014**

**Related U.S. Application Data**

(63) Continuation-in-part of application No. 29/472,254, filed on Nov. 11, 2013.

(51) **LOC (10) Cl.** ..... **14-03**

(52) **U.S. Cl.**  
USPC ..... **D14/253**

(58) **Field of Classification Search**

USPC ..... D3/215, 218, 328; D8/355; D12/223, D12/415; D14/217, 238.1, 251, 253, 344, D14/432, 433, 439, 447, 451, 452, 483; D16/214, 242, 243; 248/121, 125.1, 248/176.1, 177.1, 178.1, 179.1, 180.1, 248/181.1, 181.2, 201, 205.1, 309.1, 310, 248/314, 450, 454, 682, 686, 688; 361/679.01, 679.02, 679.21, 679.26, 361/679.3, 679.55, 679.56, 808, 809  
See application file for complete search history.

(56) **References Cited**

**U.S. PATENT DOCUMENTS**

D337,333	S	*	7/1993	Turk	.....	D14/251
8,672,374	B1	*	3/2014	Webber	.....	294/25
8,740,270	B1	*	6/2014	Mizell et al.	.....	294/25
D719,961	S	*	12/2014	Xiang et al.	.....	D14/447
2012/0068043	A1	*	3/2012	Daigle et al.	.....	248/682
2013/0083507	A1	*	4/2013	Guirlinger	.....	361/809

\* cited by examiner

*Primary Examiner* — Susan Bennett Hattan

*Assistant Examiner* — Leanne Was

(74) *Attorney, Agent, or Firm* — Locke Lord LLP

(57) **CLAIM**

The ornamental design for a quick release apparatus for a portable device, as shown and described.

**DESCRIPTION**

FIG. 1 is a perspective view of a quick release apparatus for a portable device, embodying principles of the present invention, the quick release system having a first portion of the quick release system showing a clasp and a slide forming a slide path, and a mating second portion of the quick release system showing an insert for the slide path.

FIG. 2 is a front view of the mating second portion of the quick release system.

FIG. 3 is a rear view of the mating second portion of the quick release system.

FIG. 4 is a left side view of the mating second portion of the quick release system.

FIG. 5 is a right side view of the mating second portion of the quick release system.

FIG. 6 is a top view of the mating second portion of the quick release system.

FIG. 7 is a bottom view of the mating second portion of the quick release system.

FIG. 8 is a perspective assembly view of the quick release system.

FIG. 9 is a perspective view of the slide forming the slide path from FIG. 1; and,

FIG. 10 is an end view of the slide forming the slide path from FIG. 1.

The broken lines shown in the figures are for the purpose of illustrating portions of the quick release system or the environmental structure that form no part of the claimed design.

**1 Claim, 7 Drawing Sheets**

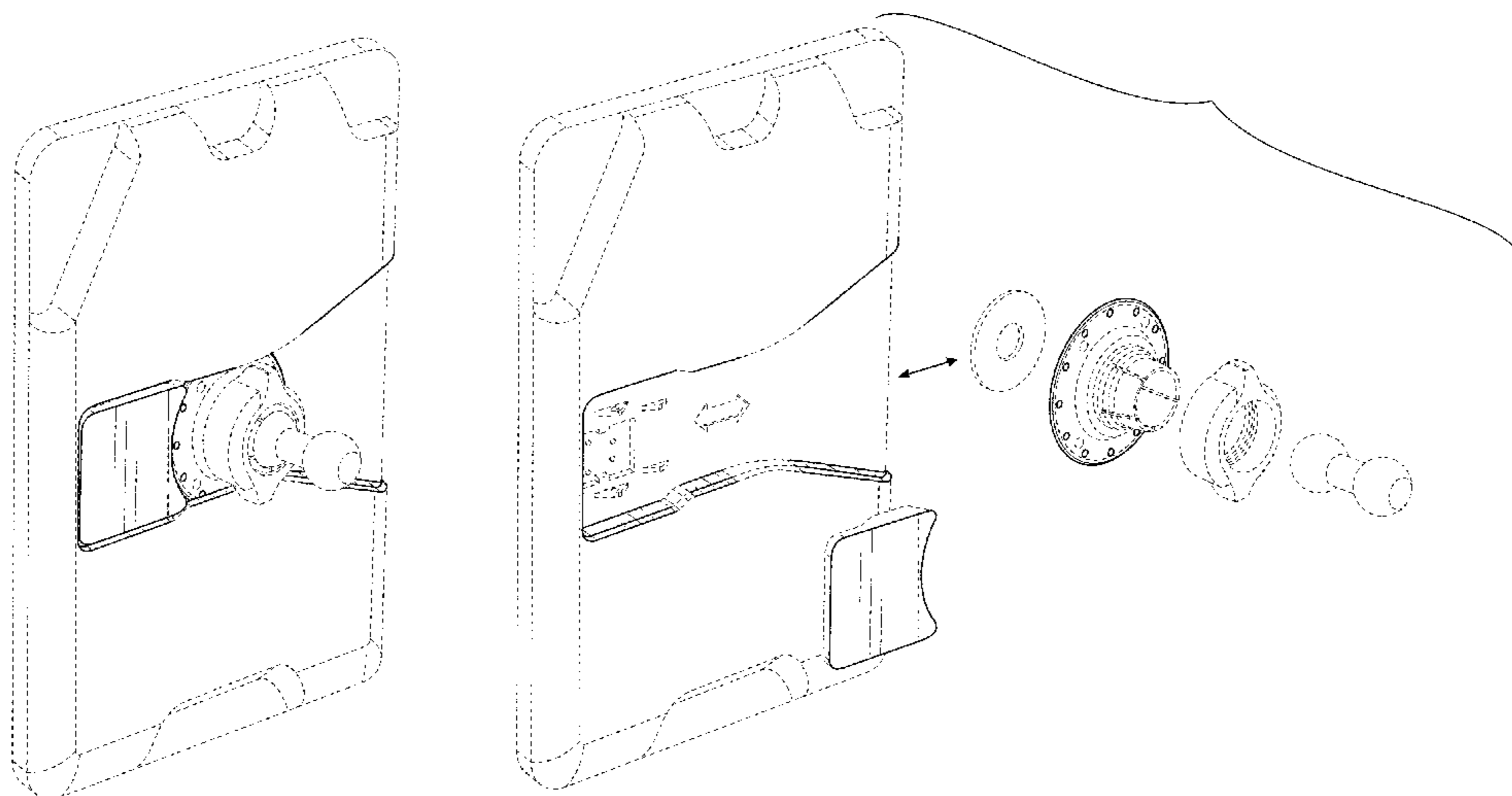

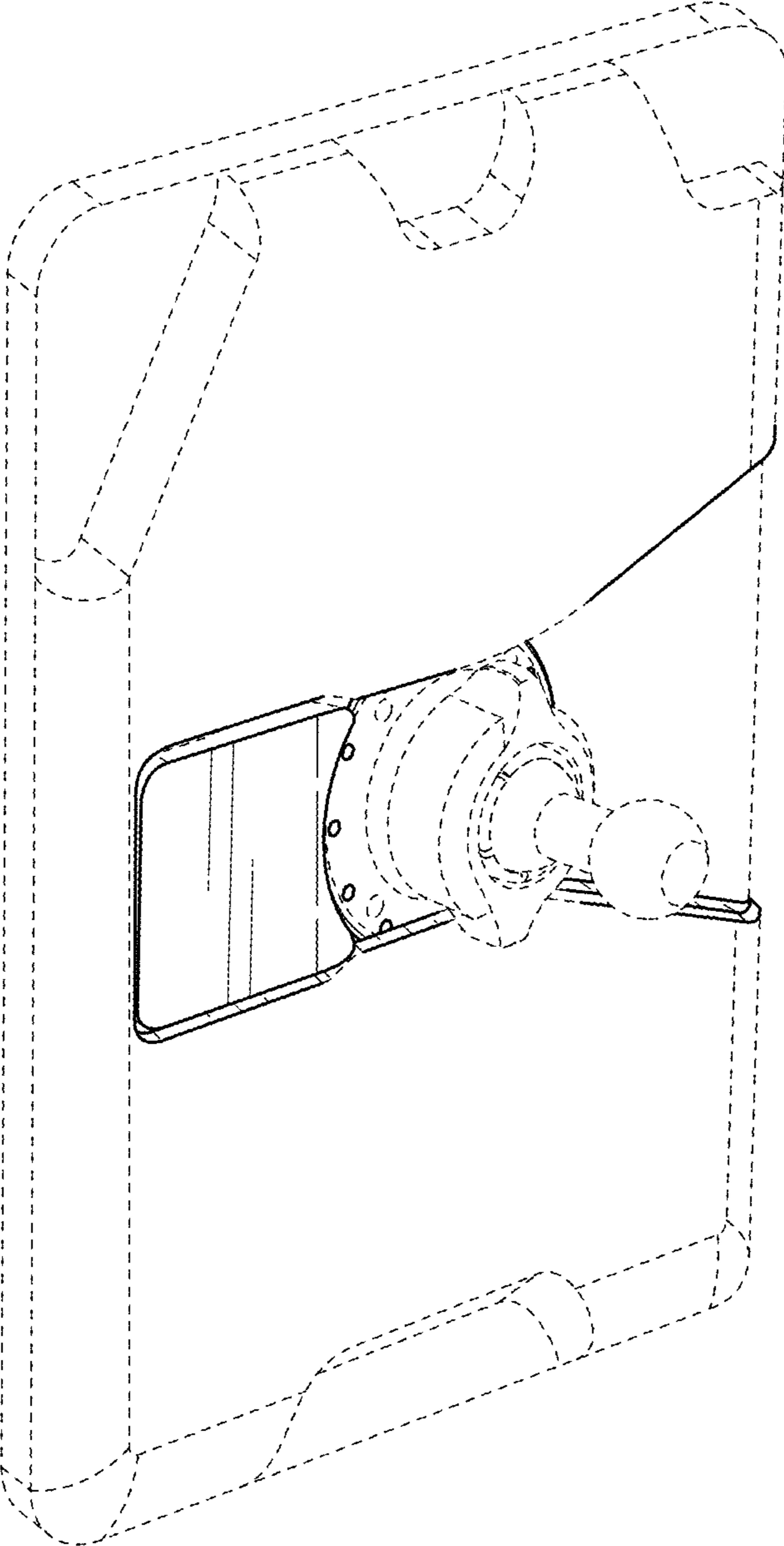

FIG. 1

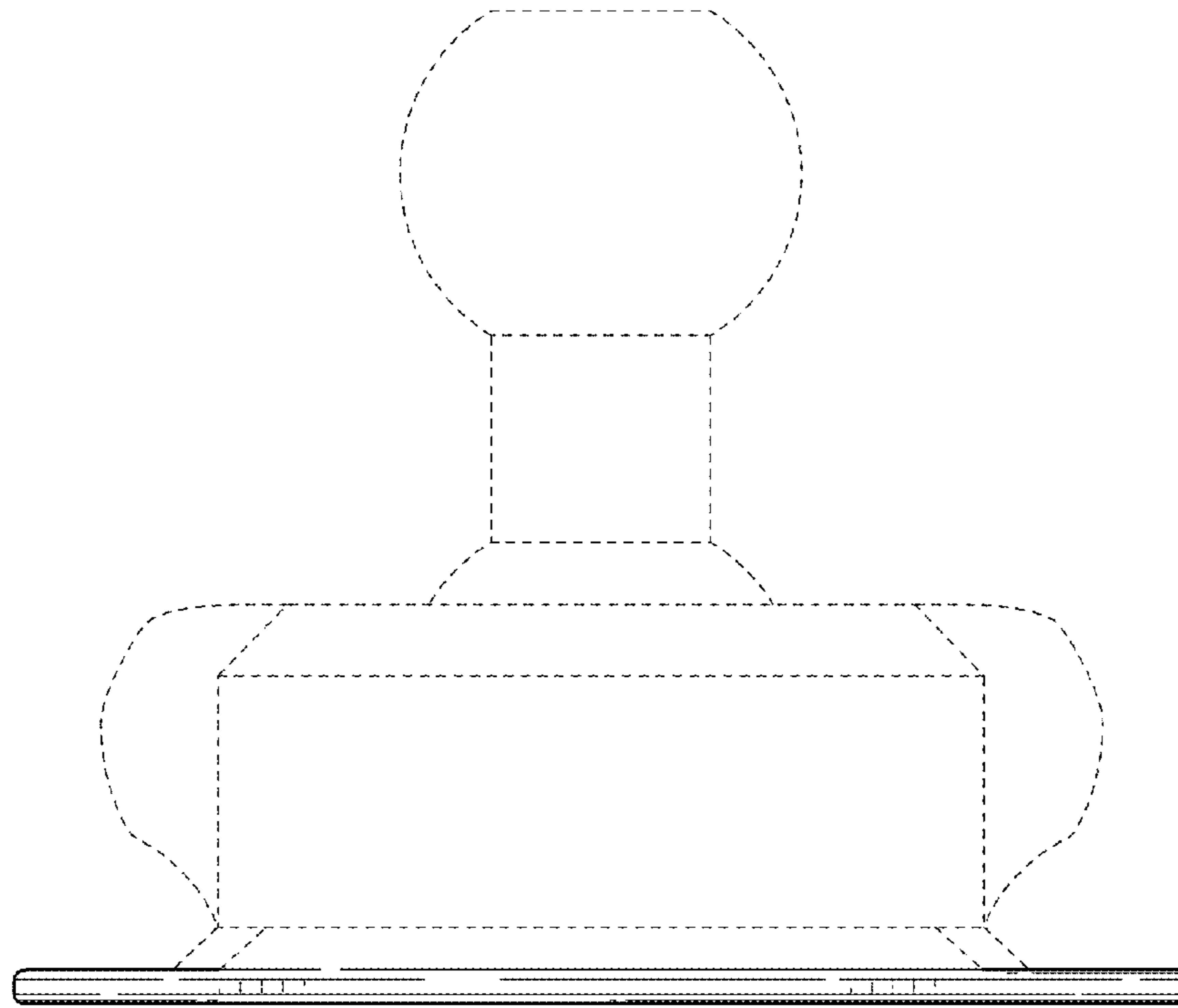

FIG. 2

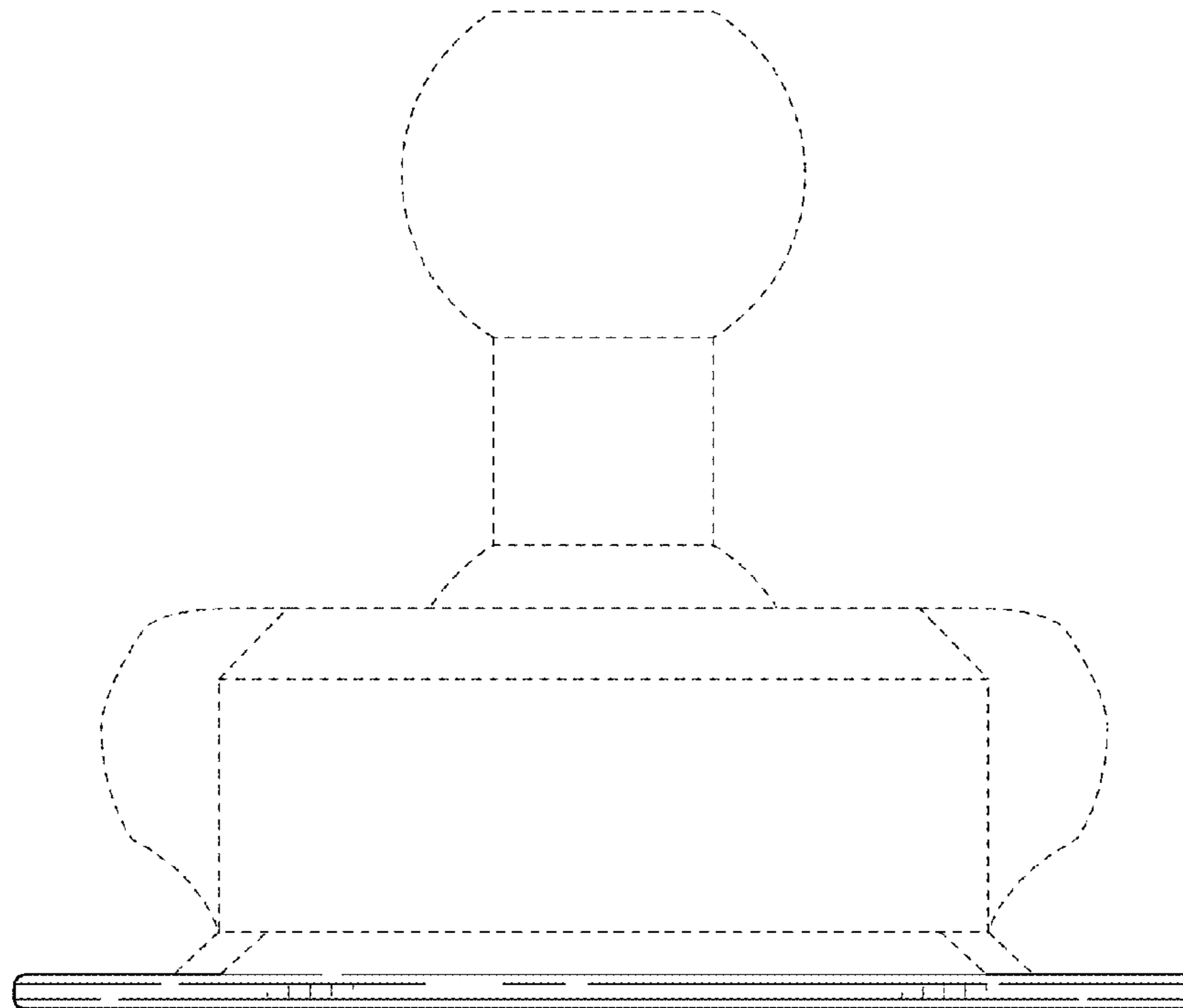

FIG. 3

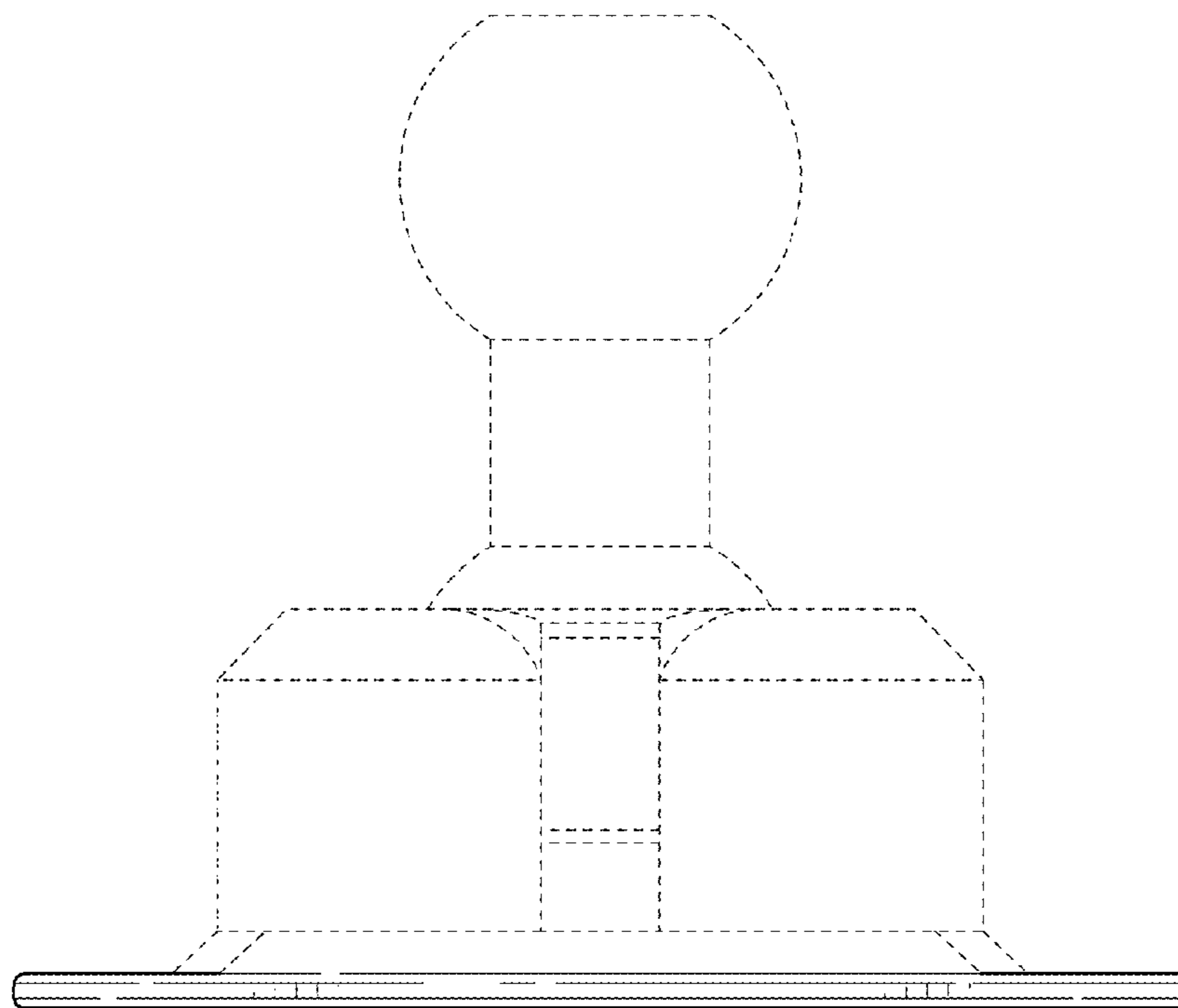

FIG. 4

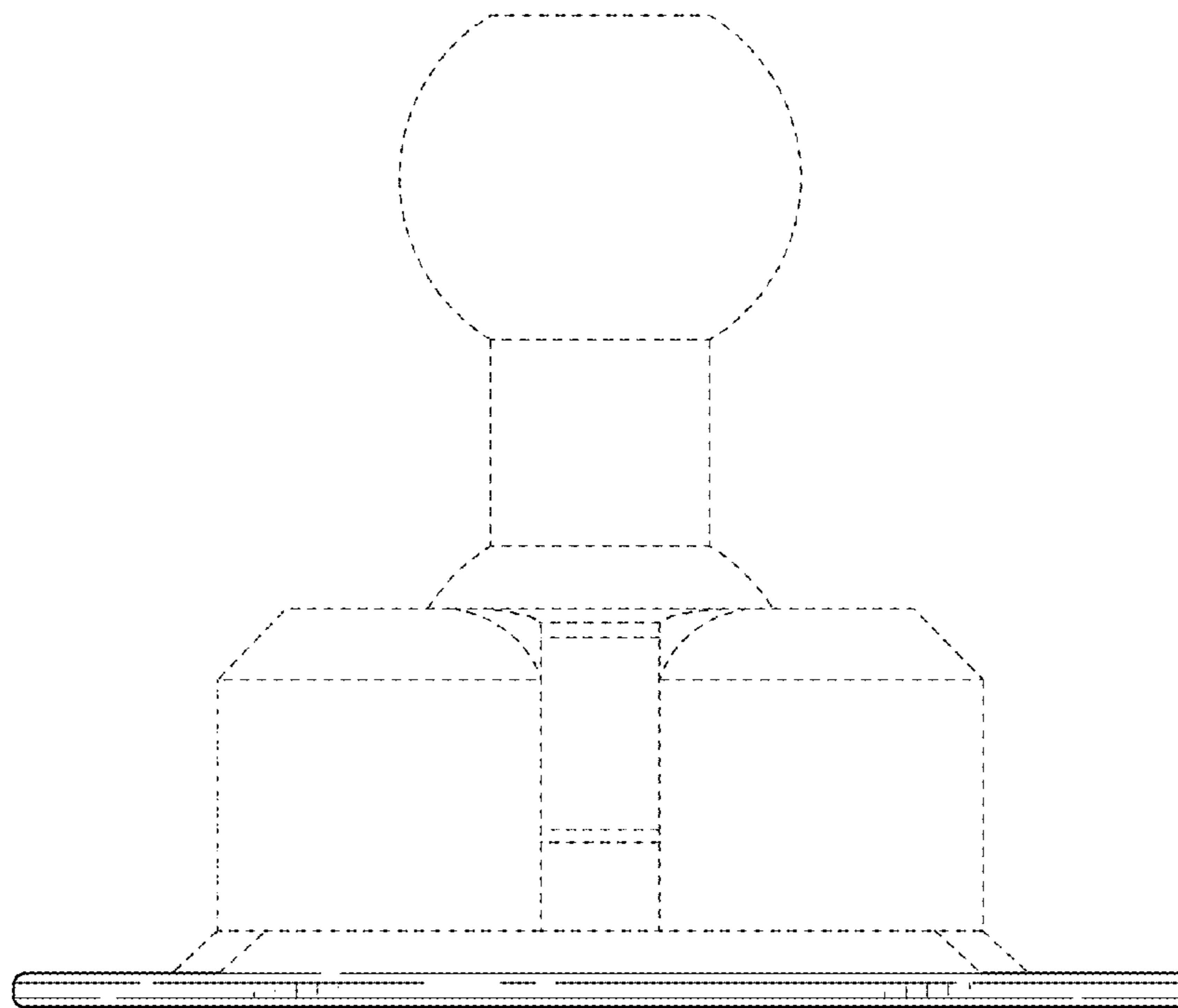

FIG. 5

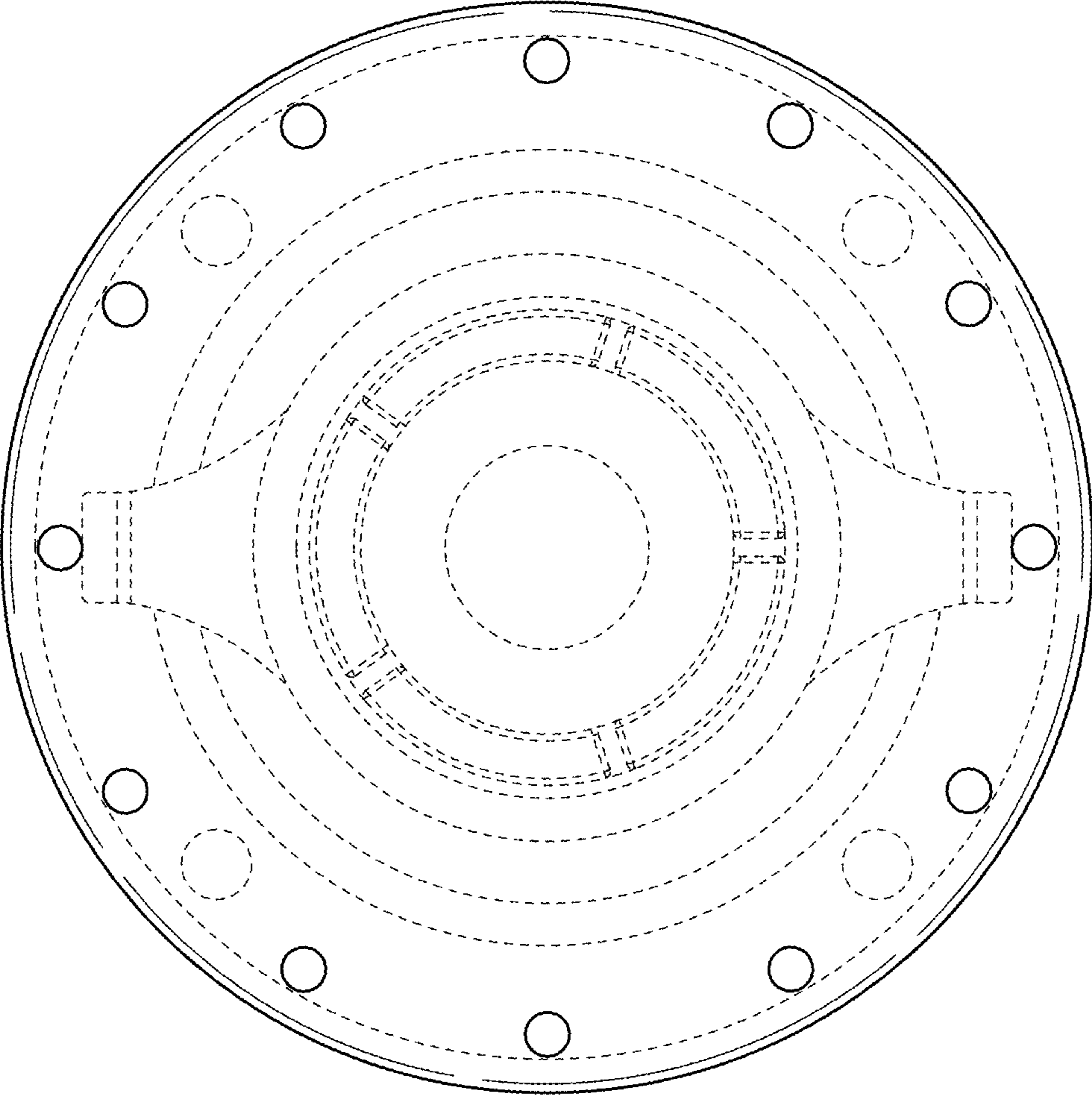

FIG. 6

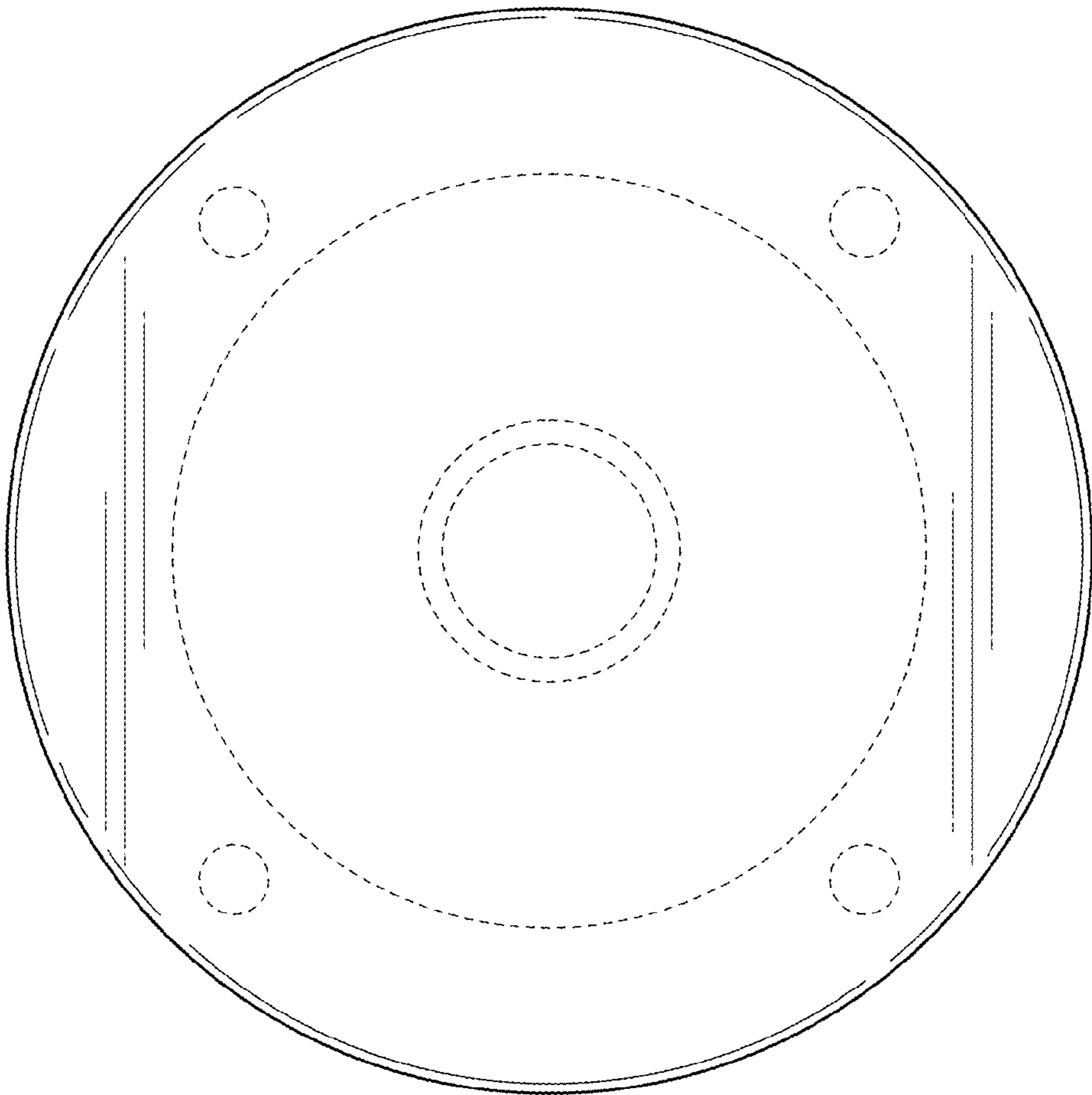

FIG. 7

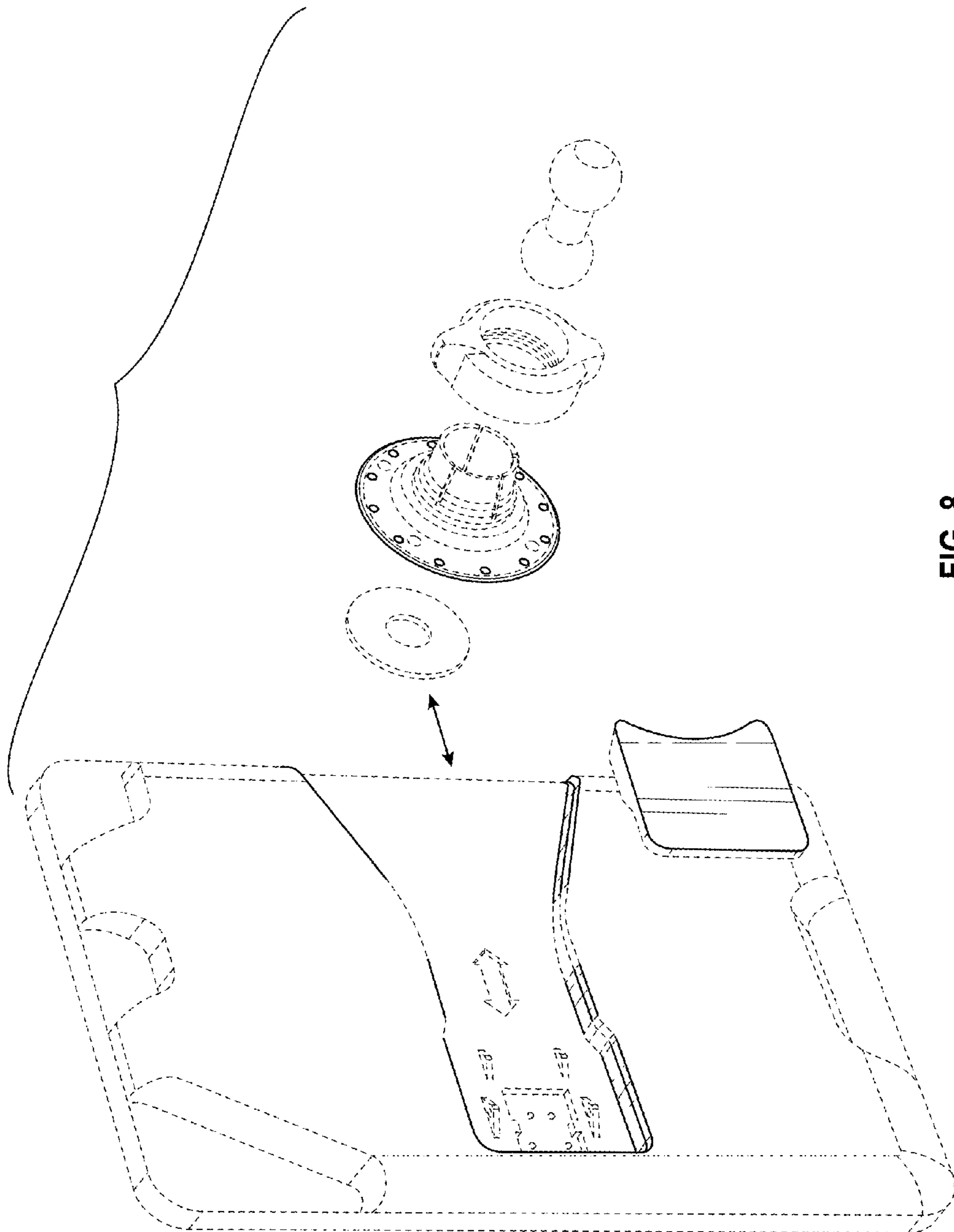

FIG. 8

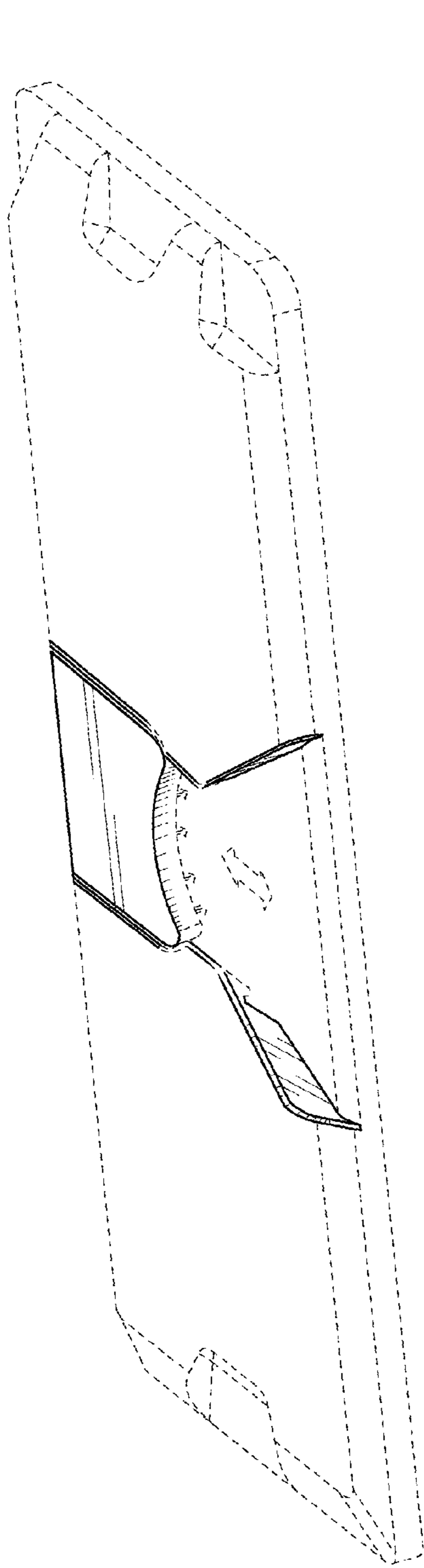

FIG. 9

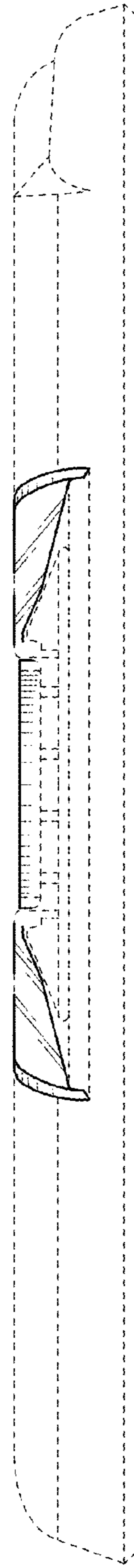

FIG. 10