



US00D725577S

(12) **United States Design Patent**
Vickers

(10) **Patent No.:** **US D725,577 S**

(45) **Date of Patent:** **** *Mar. 31, 2015**

(54) **AIRCRAFT WITH FOLDING WINGS**

(56) **References Cited**

(71) Applicant: **Paul W. Vickers**, Hamilton (NZ)

U.S. PATENT DOCUMENTS

(72) Inventor: **Paul W. Vickers**, Hamilton (NZ)

D137,661	S	*	4/1944	Sheffield	D12/344
D178,584	S	*	8/1956	Toth	D12/324
4,121,791	A	*	10/1978	Taylor et al.	244/120
4,962,978	A	*	10/1990	Weston	244/105
D325,021	S	*	3/1992	Mouton, Jr.	D12/324
D392,937	S	*	3/1998	Brichard et al.	D12/324
5,913,493	A	*	6/1999	Labouchere	244/105
6,113,028	A	*	9/2000	Lohse et al.	244/13
D613,202	S	*	4/2010	Rodriguez et al.	D12/3
D620,392	S	*	7/2010	Rodriguez et al.	D12/3
D620,838	S	*	8/2010	Miralles et al.	D12/3
8,177,162	B2	*	5/2012	Karkow et al.	244/105
2006/0255208	A1	*	11/2006	Hawkins	244/105

(*) Notice: This patent is subject to a terminal disclaimer.

(**) Term: **14 Years**

* cited by examiner

(21) Appl. No.: **29/470,792**

(22) Filed: **Oct. 25, 2013**

Primary Examiner — Martie K Holtje

(51) **LOC (10) Cl.** **12-07**

(52) **U.S. Cl.**
USPC **D12/324**; D12/3; D12/344

(74) *Attorney, Agent, or Firm* — Law Offices of Michael L. Wise, LLC

(58) **Field of Classification Search**
 CPC B64C 35/00; B64C 35/001; B64C 35/008;
 B64C 3/56; B64C 1/00; B64C 1/065; B64C
 1/14; B64C 2001/00; B64C 2005/543
 USPC D12/2, 3, 4, 16.1, 319, 324, 326–334,
 D12/337, 338, 339, 341, 344, 345;
 D21/430, 436, 441, 442, 446–450, 451,
 D21/452, 453; 244/2, 5, 6, 7 R, 7 C, 7 A, 8,
 244/13, 55, 56, 101, 105, 106, 120, 125,
 244/17.19; 280/1.12, 1.21; 446/34–38,
 446/57–59, 61, 62, 230–236

See application file for complete search history.

(57) **CLAIM**
The ornamental design for an aircraft with folding wings, as shown.

DESCRIPTION

FIG. 1 is a top, right front perspective view of an aircraft with folding wings showing my new design;
 FIG. 2 is a right side elevational view thereof;
 FIG. 3 is a left side elevational view thereof;
 FIG. 4 is a front elevational view thereof;
 FIG. 5 is a rear elevational view thereof;
 FIG. 6 is a top plan view drawn to a reduced scale; and,
 FIG. 7 is a bottom plan view of FIG. 6.

1 Claim, 4 Drawing Sheets

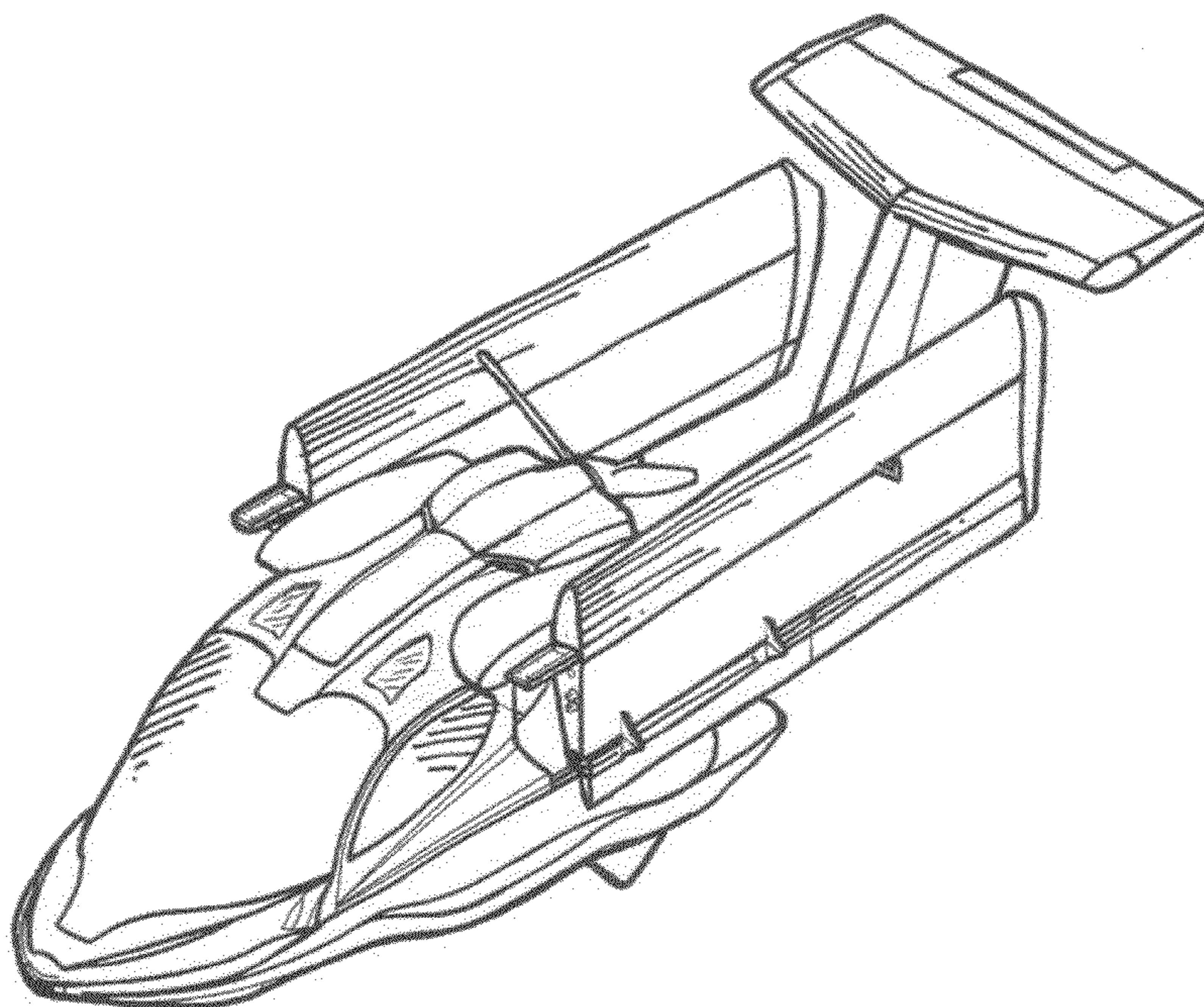

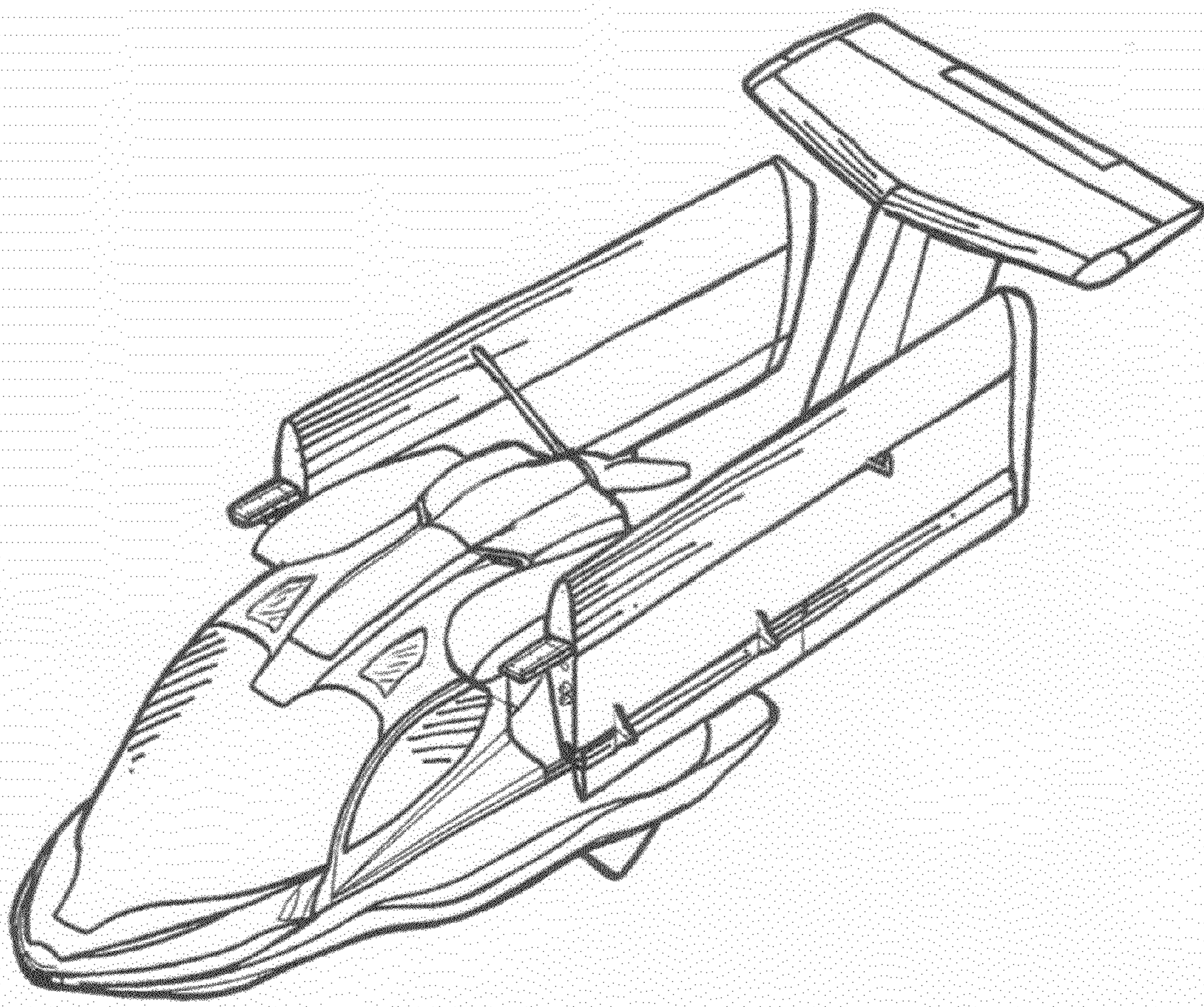

FIG. 1

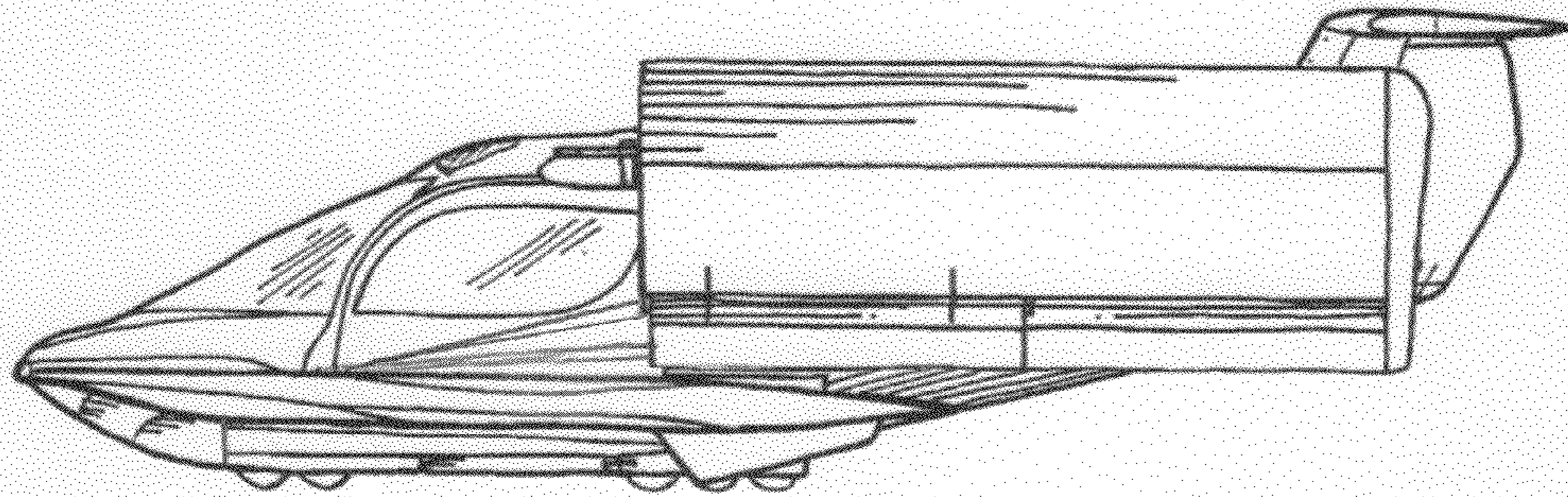

FIG. 2

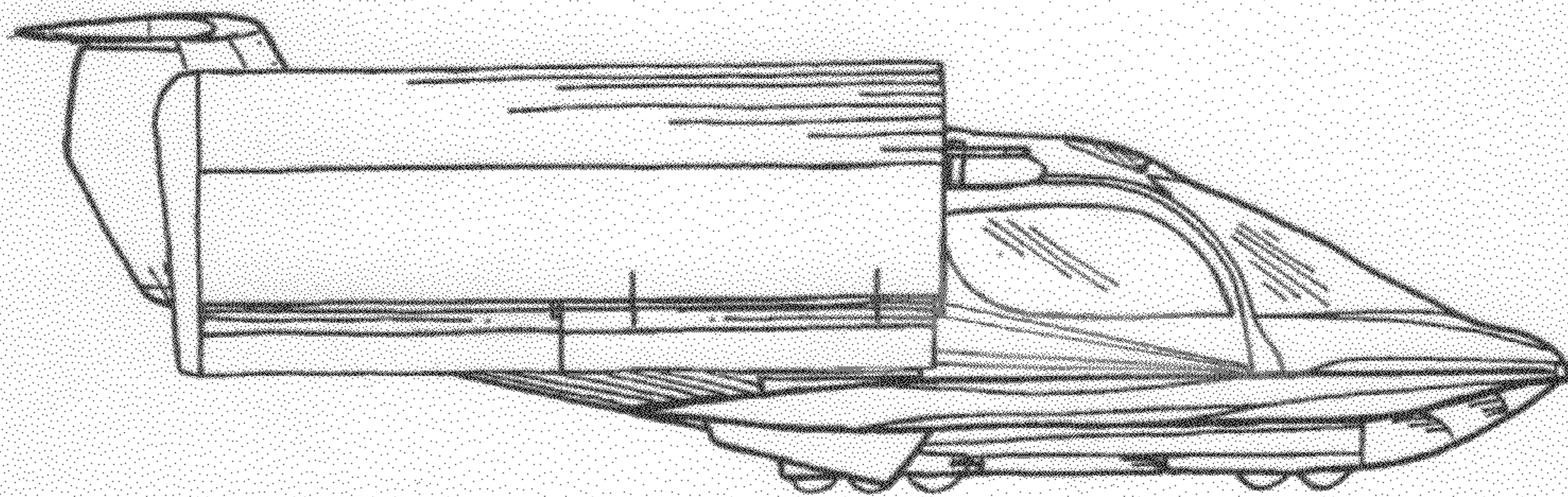

FIG. 3

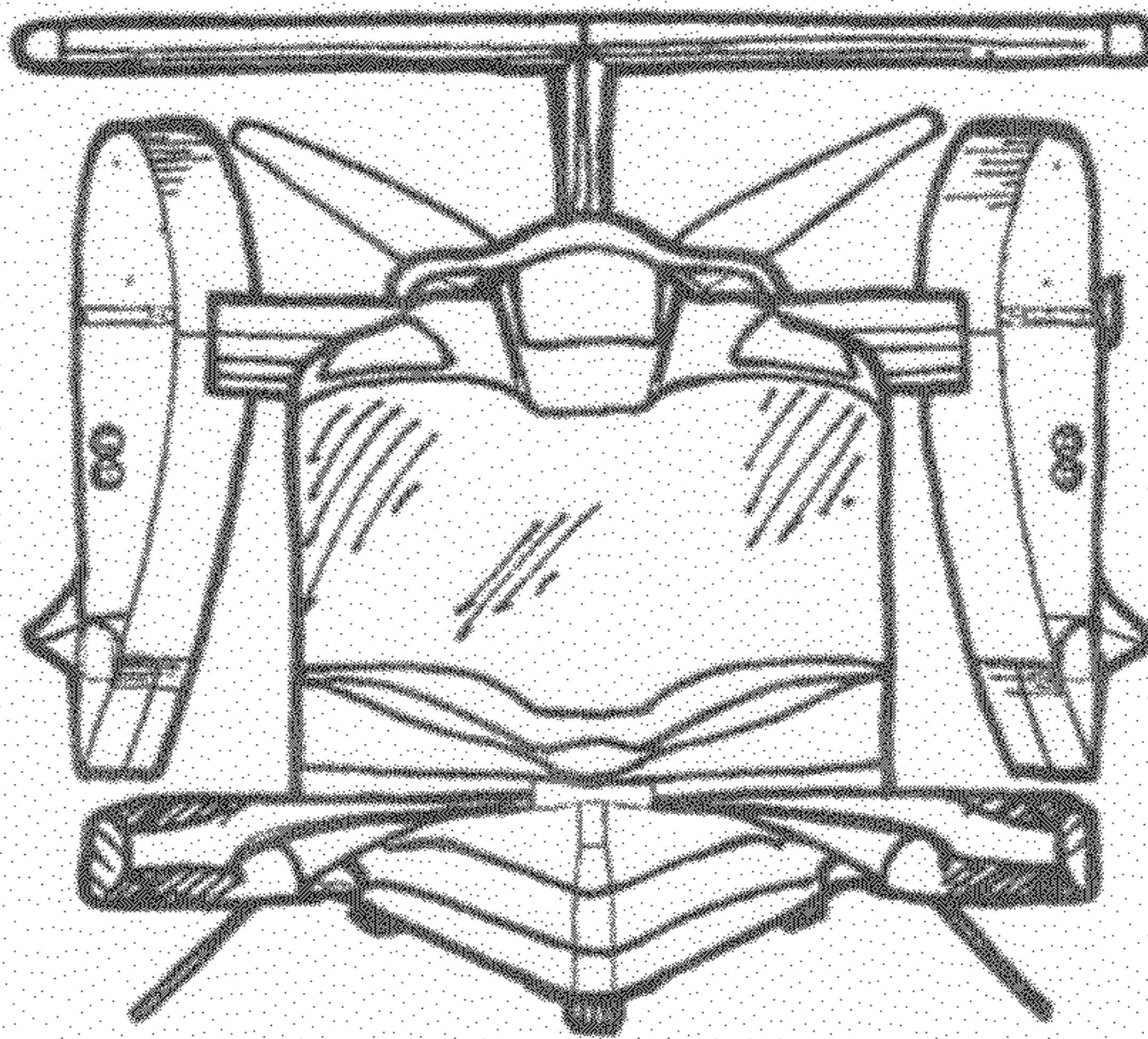

FIG. 4

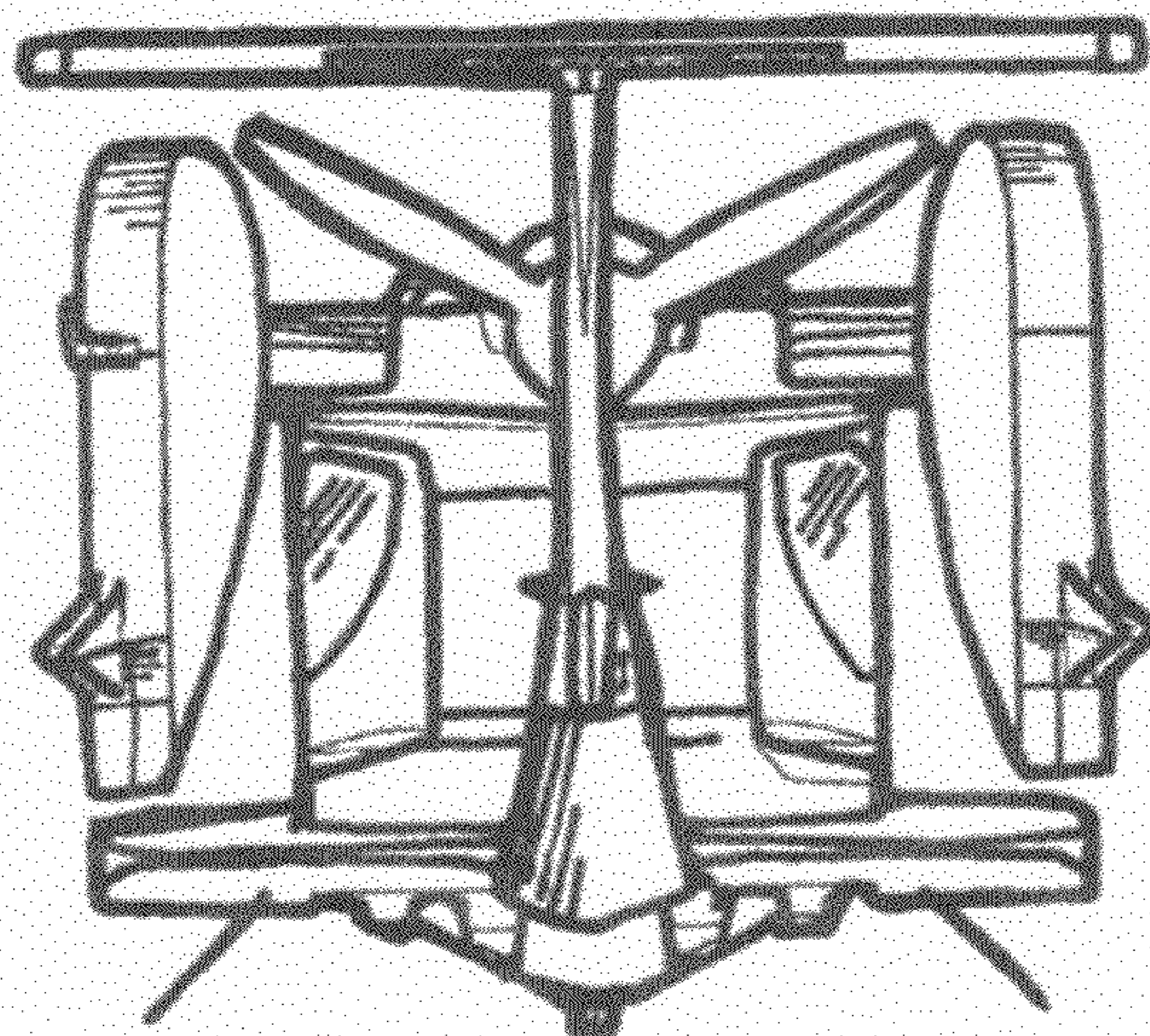

FIG. 5

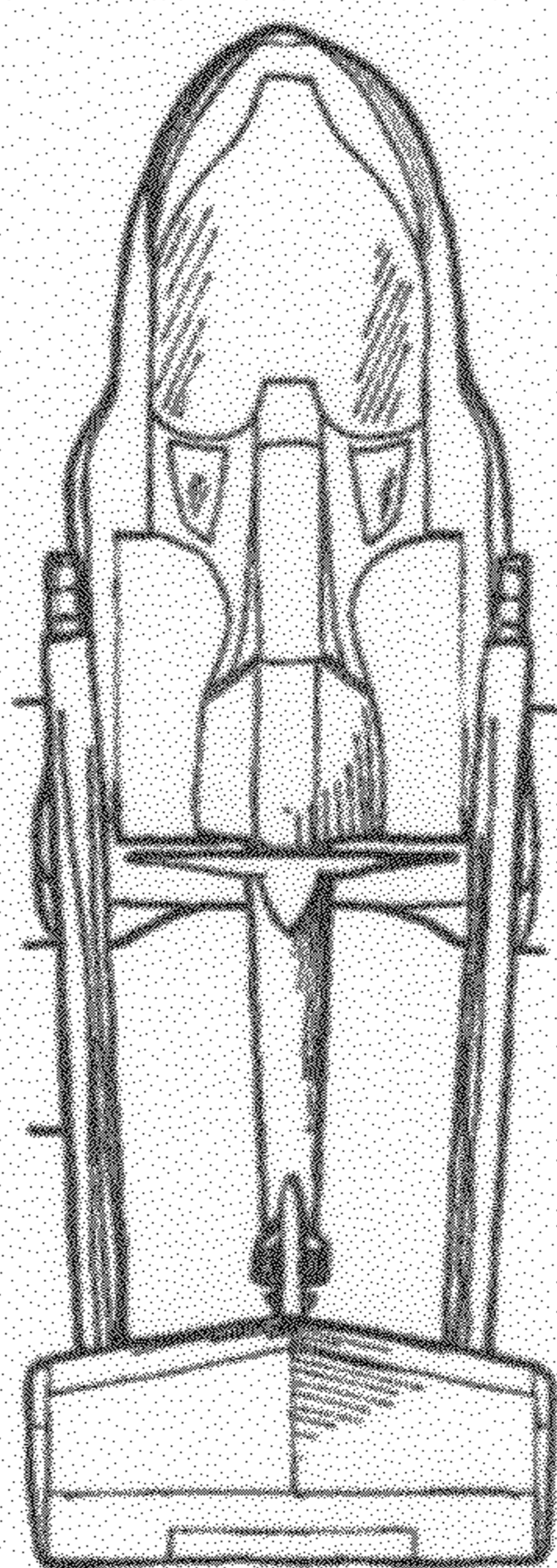

FIG. 6

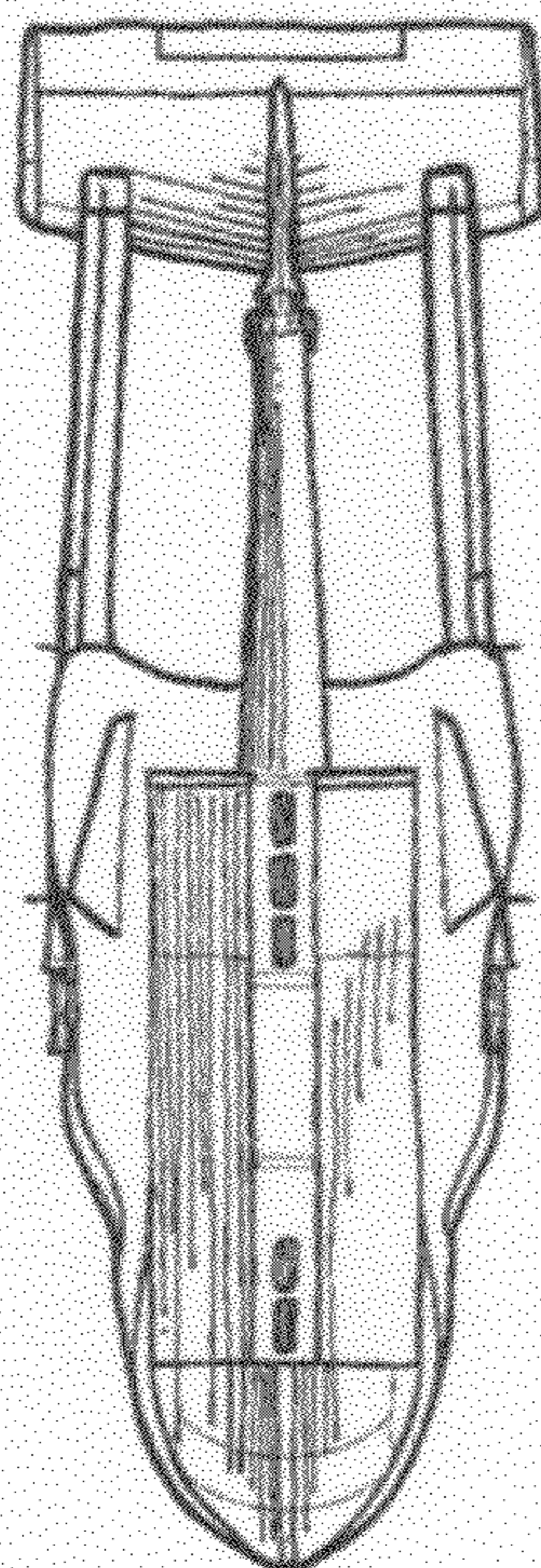

FIG. 7