



US00D725455S

(12) **United States Design Patent**
Carlini

(10) **Patent No.:** **US D725,455 S**
(45) **Date of Patent:** **** Mar. 31, 2015**

(54) **HANDLEBAR**

(74) *Attorney, Agent, or Firm* — John F. Rollins

(71) Applicant: **Carlini Enterprises Inc.**, Santa Ana, CA
(US)

(57) **CLAIM**
The ornamental design for a handlebar, as shown and described.

(72) Inventor: **Anthony J. Carlini**, Newport Beach, CA
(US)

DESCRIPTION

(**) Term: **14 Years**

FIG. 1 is a right front perspective of a handlebar showing our new design;
FIG. 2 is right side view of the handlebar of FIG. 1;
FIG. 3 is left side view of the handlebar of FIG. 1;
FIG. 4 is a front view of the handlebar of FIG. 1;
FIG. 5 is a rear view of the handlebar of FIG. 1;
FIG. 6 is a top view of the handlebar of FIG. 1;
FIG. 7 is a bottom view of the handlebar of FIG. 1;
FIG. 8 is a right front perspective of a handlebar according to a second embodiment;
FIG. 9 is right side view of the handlebar of FIG. 8;
FIG. 10 is left side view of the handlebar of FIG. 8;
FIG. 11 is a front view of the handlebar of FIG. 8;
FIG. 12 is a rear view of the handlebar of FIG. 8;
FIG. 13 is a top view of the handlebar of FIG. 8;
FIG. 14 is a bottom view of the handlebar of FIG. 8;
FIG. 15 is a right front perspective of a handlebar according to a third embodiment;
FIG. 16 is right side view of the handlebar of FIG. 15;
FIG. 17 is left side view of the handlebar of FIG. 15;
FIG. 18 is a front view of the handlebar of FIG. 15;
FIG. 19 is a rear view of the handlebar of FIG. 15;
FIG. 20 is a top view of the handlebar of FIG. 15; and,
FIG. 21 is a bottom view of the handlebar of FIG. 15.
The broken lines are for environmental purposes only and form no part of the claimed design.

(21) Appl. No.: **29/460,712**

(22) Filed: **Jul. 12, 2013**

(51) **LOC (10) Cl.** **08-06**

(52) **U.S. Cl.**
USPC **D8/303**

(58) **Field of Classification Search**
CPC B62K 21/12
USPC D8/303, 300, 315, 312, 321, 306;
74/551.1, 551.8, 551.9; 411/500;
16/421, 430; D21/432, 682; D12/107,
D12/111, 114, 117, 118
See application file for complete search history.

(56) **References Cited**

U.S. PATENT DOCUMENTS

5,199,322 A *	4/1993	Wu	74/551.1
D458,566 S	6/2002	Carlini	
D477,798 S	7/2003	Bean	
D483,307 S	12/2003	Gibson	

(Continued)

Primary Examiner — George D Kirschbaum
Assistant Examiner — Kendra L Hamilton

1 Claim, 9 Drawing Sheets

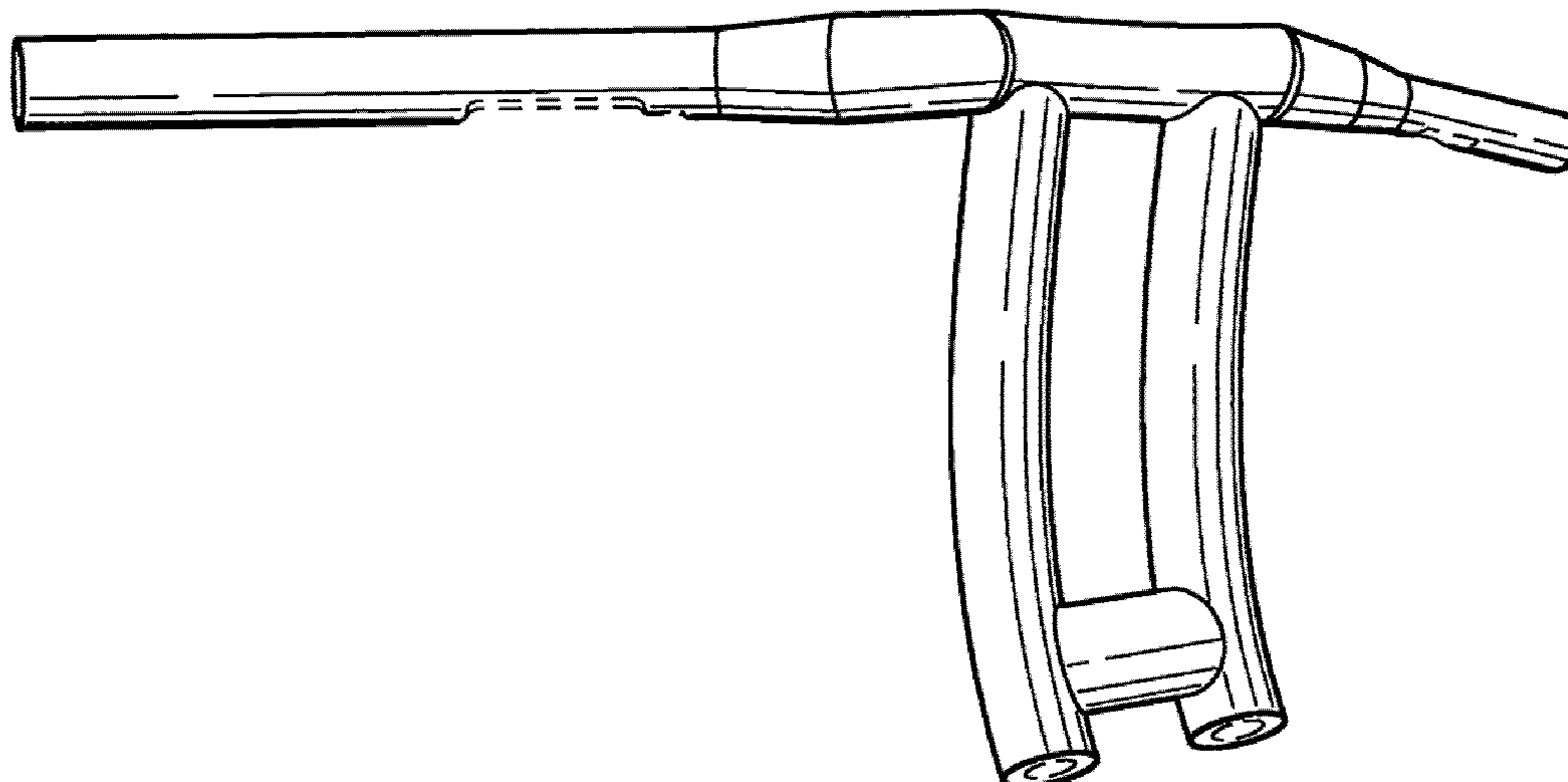

(56)

References Cited

U.S. PATENT DOCUMENTS

6,668,681	B2 *	12/2003	Flum et al.	74/551.1	D621,755	S	8/2010	Carlini	
D487,416	S *	3/2004	Lin	D12/179	D624,858	S	10/2010	Carlini	
D496,893	S	10/2004	Sieve et al.		D629,343	S	12/2010	Carlini	
D497,858	S	11/2004	Fabian		D686,547	S *	7/2013	Neilson	D12/178
7,093,698	B1 *	8/2006	Chen	188/379	D689,409	S *	9/2013	Yap	D12/111
D542,197	S	5/2007	Carlini		8,739,653	B2 *	6/2014	Hissam	74/551.2
D559,748	S	1/2008	Welch		2009/0044658	A1 *	2/2009	Yen	74/551.1
7,350,437	B2 *	4/2008	Mangano et al.	74/551.1	2009/0049949	A1 *	2/2009	Chen	74/551.1
D604,212	S	11/2009	Carlini		2009/0056495	A1 *	3/2009	Bischoff et al.	74/551.9
					2011/0219909	A1 *	9/2011	Galstad et al.	74/551.9
					2014/0174246	A1 *	6/2014	Chiang	74/551.1

* cited by examiner

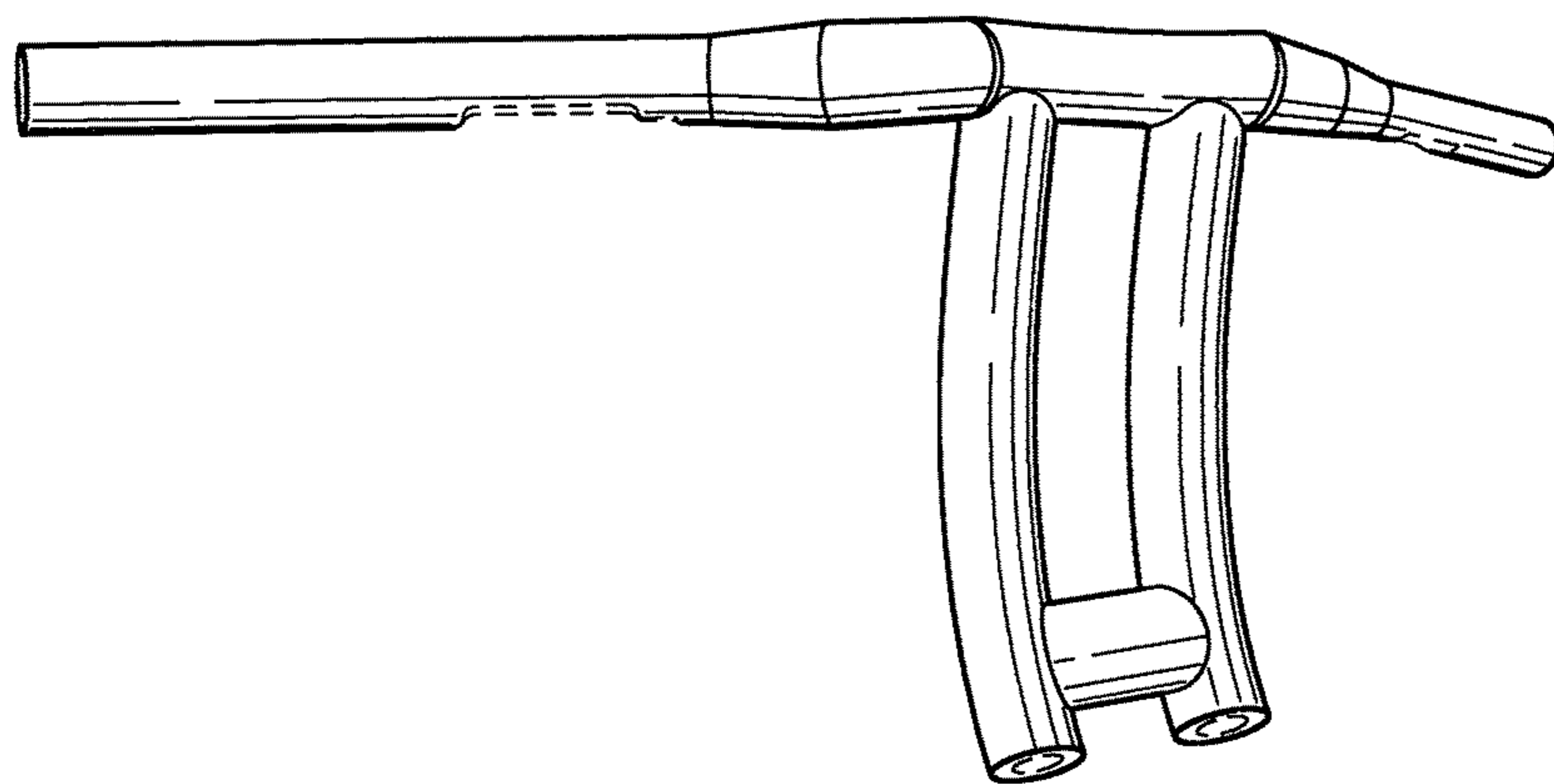

FIG. 1

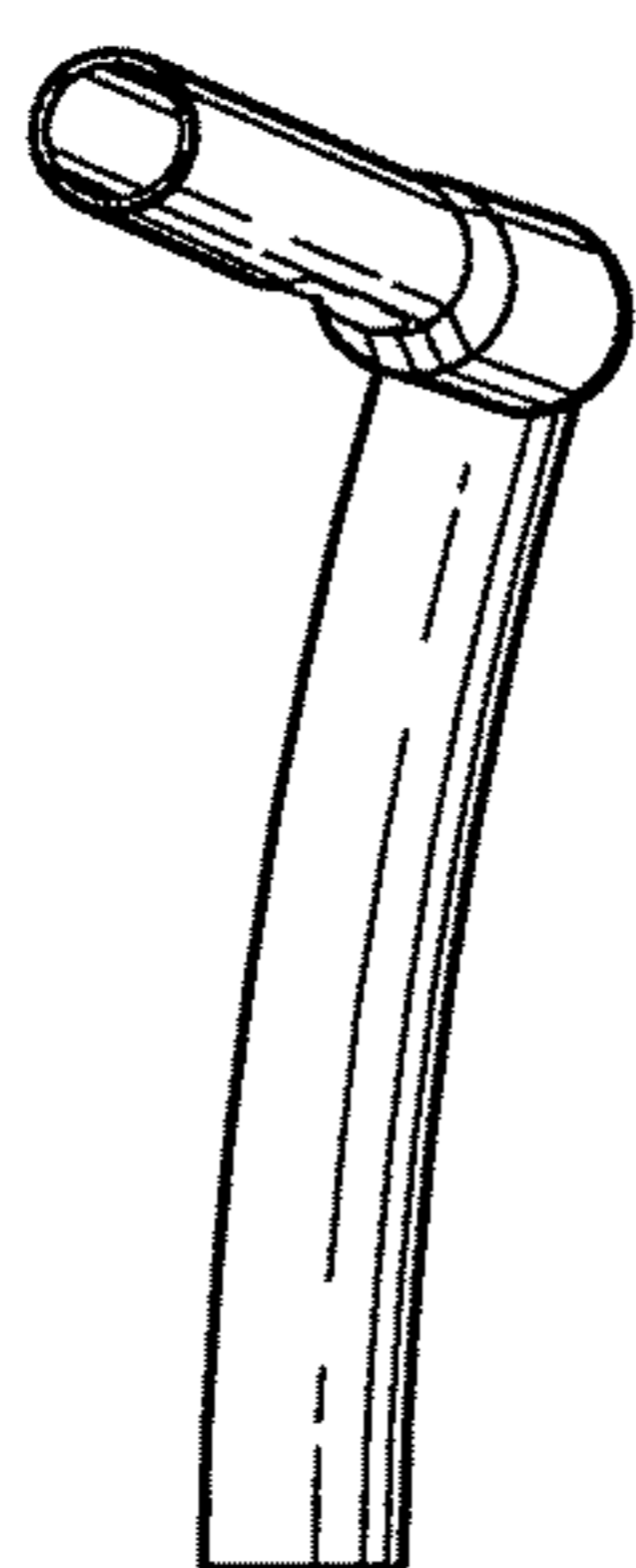

FIG. 2

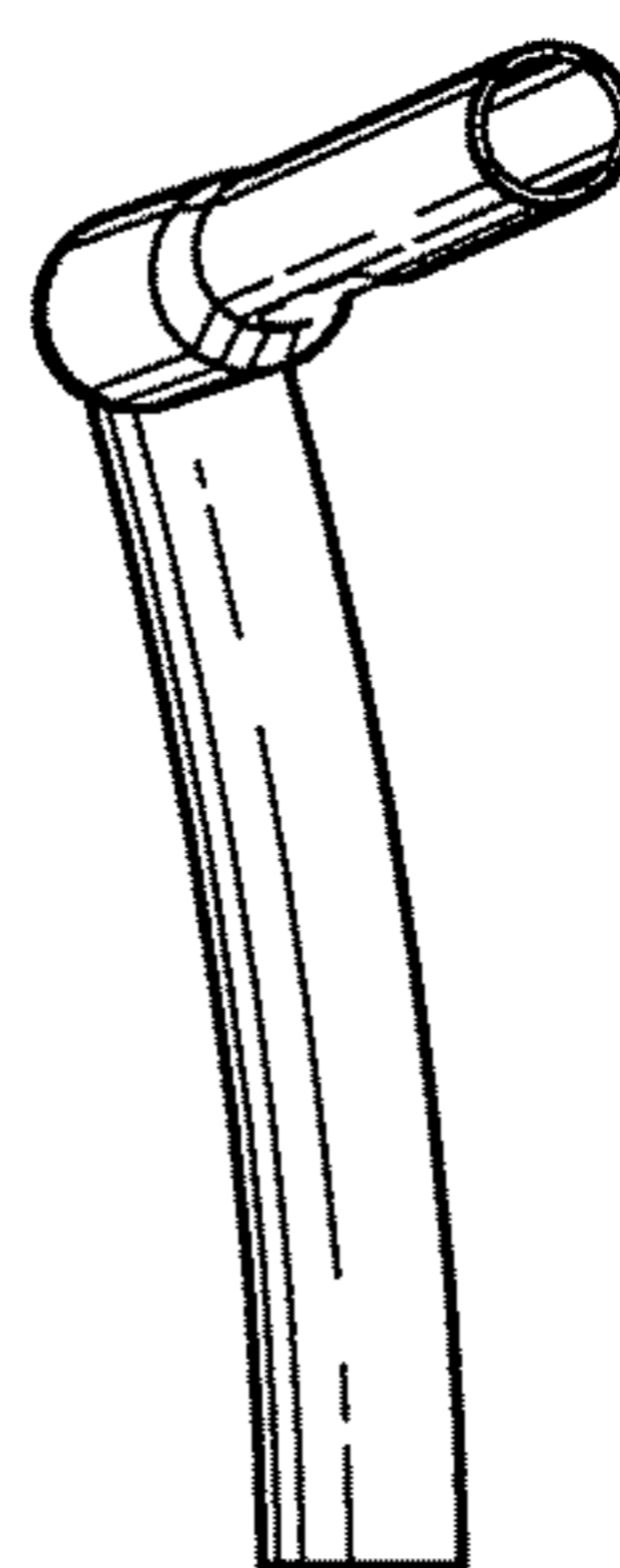

FIG. 3

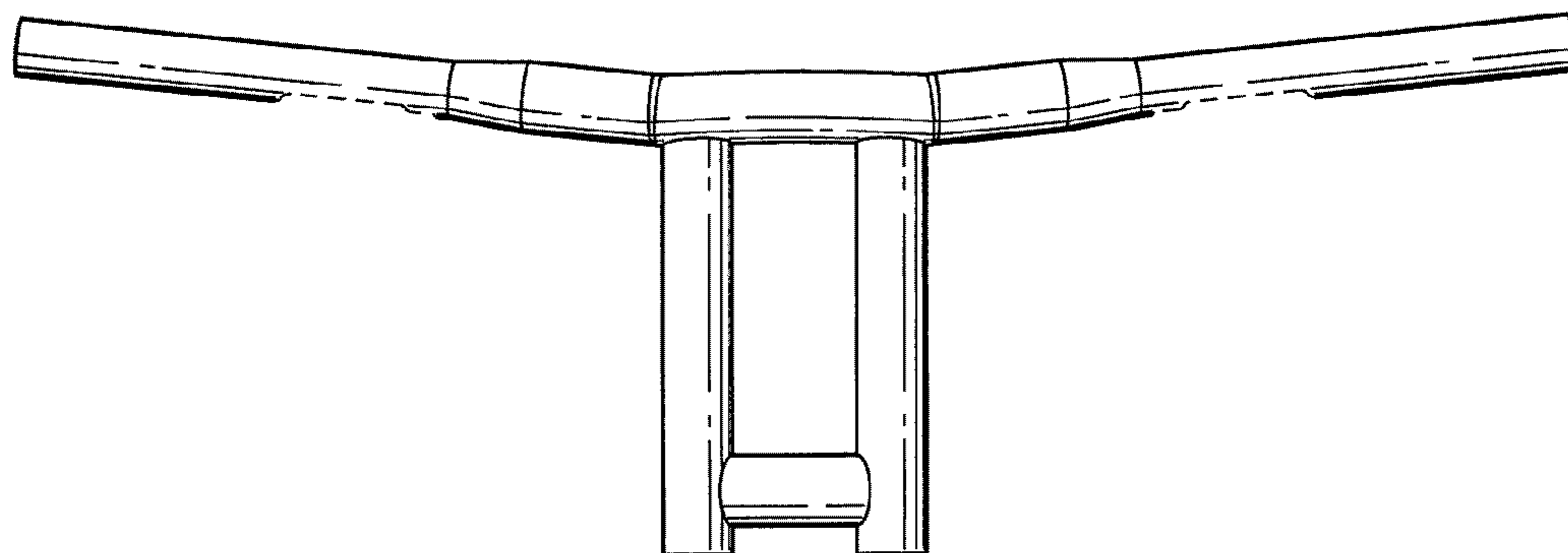

FIG. 4

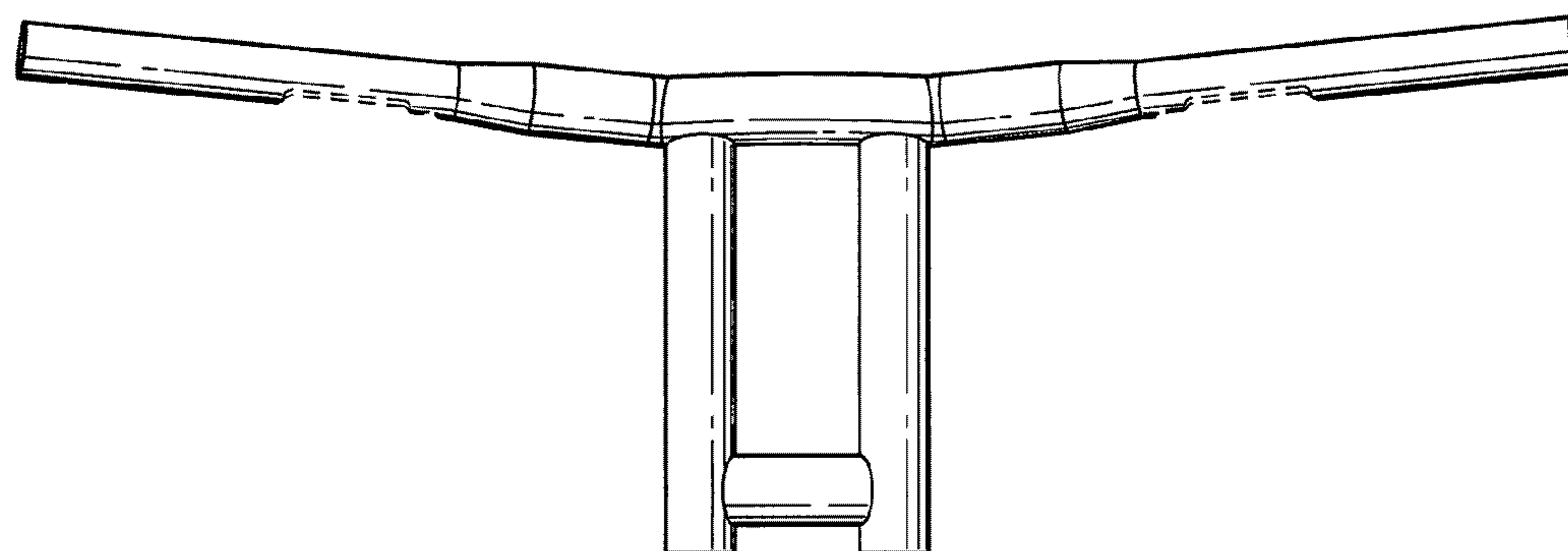

FIG. 5

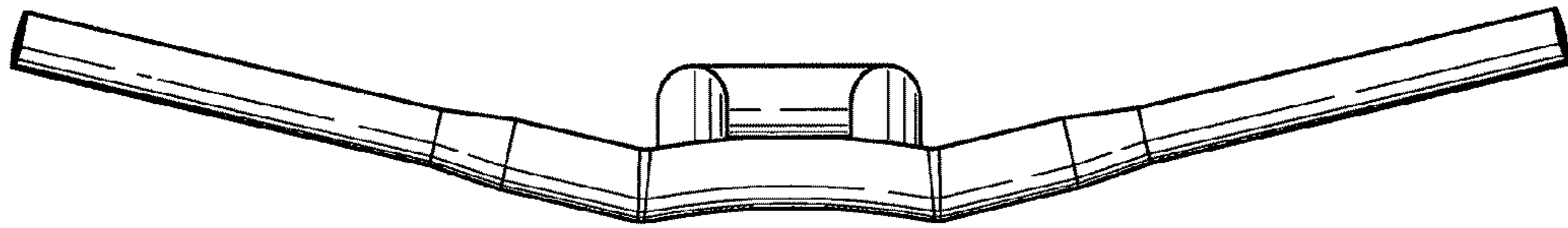

FIG. 6

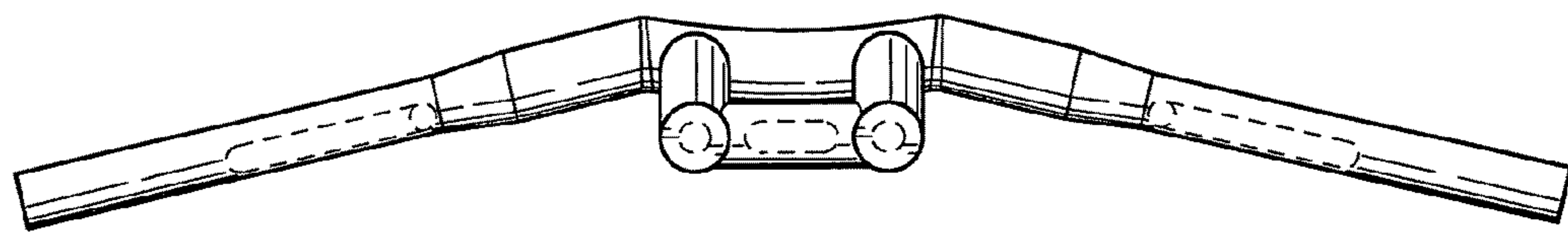

FIG. 7

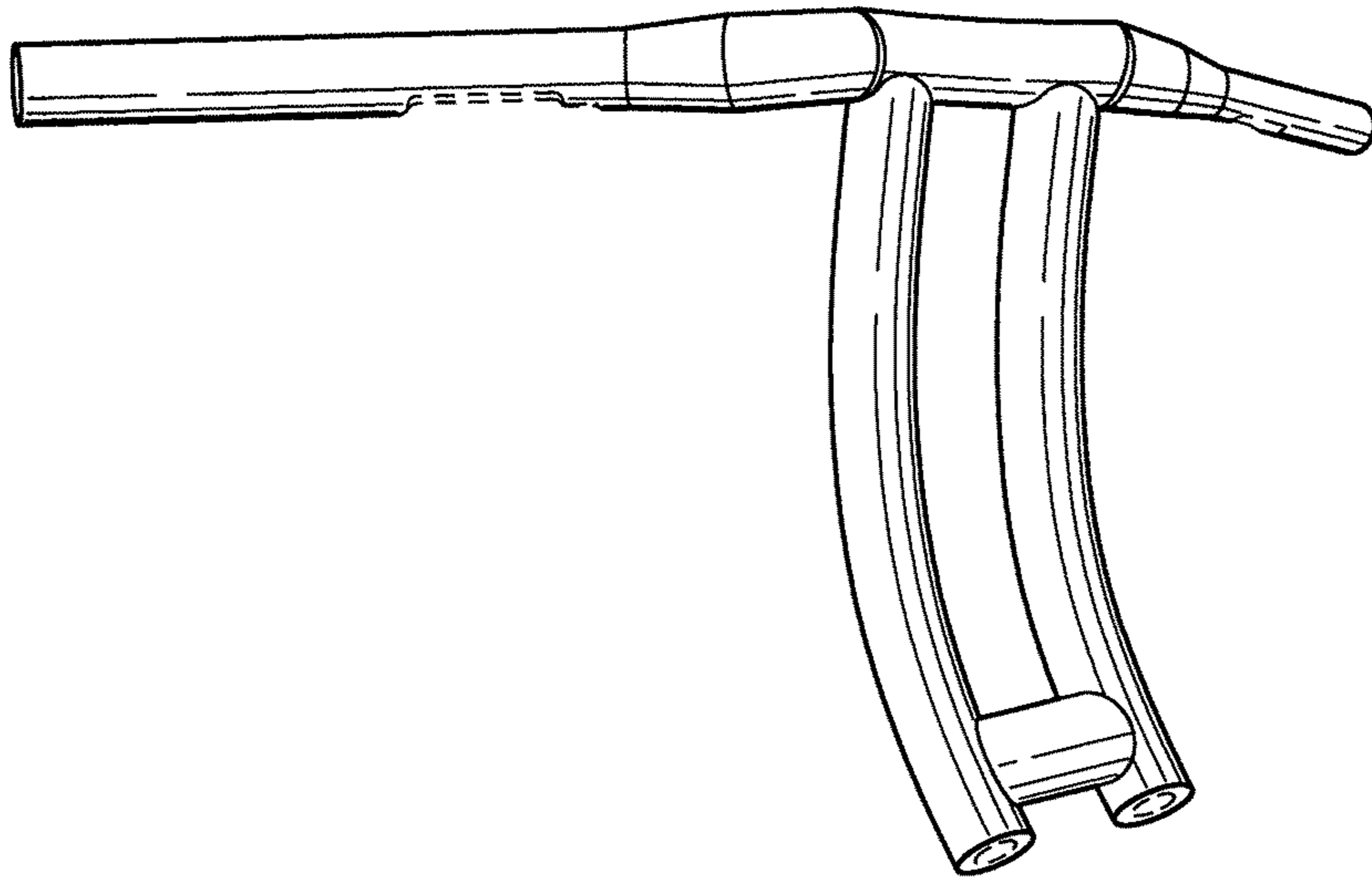

FIG. 8

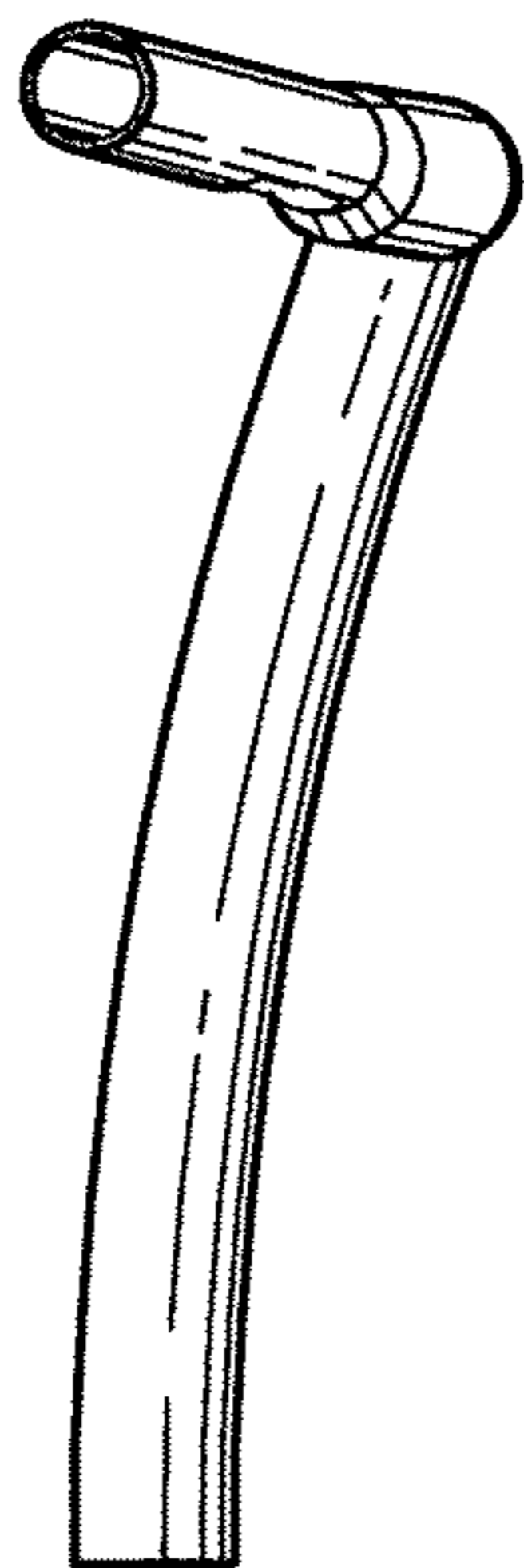

FIG. 9

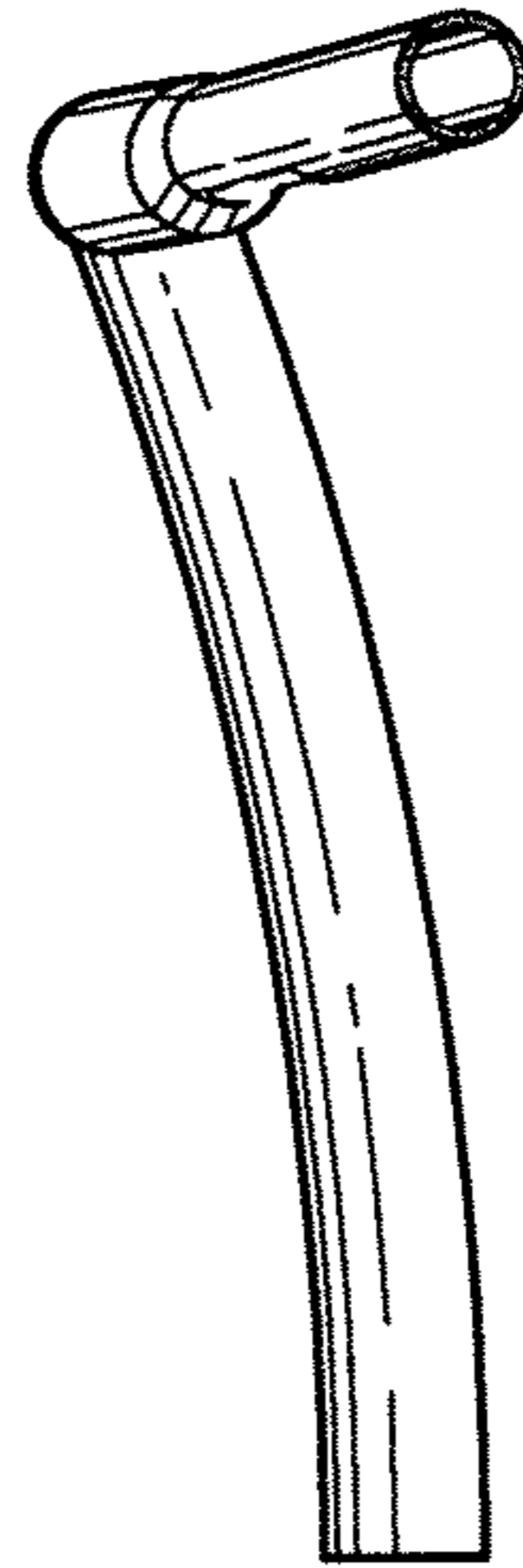

FIG. 10

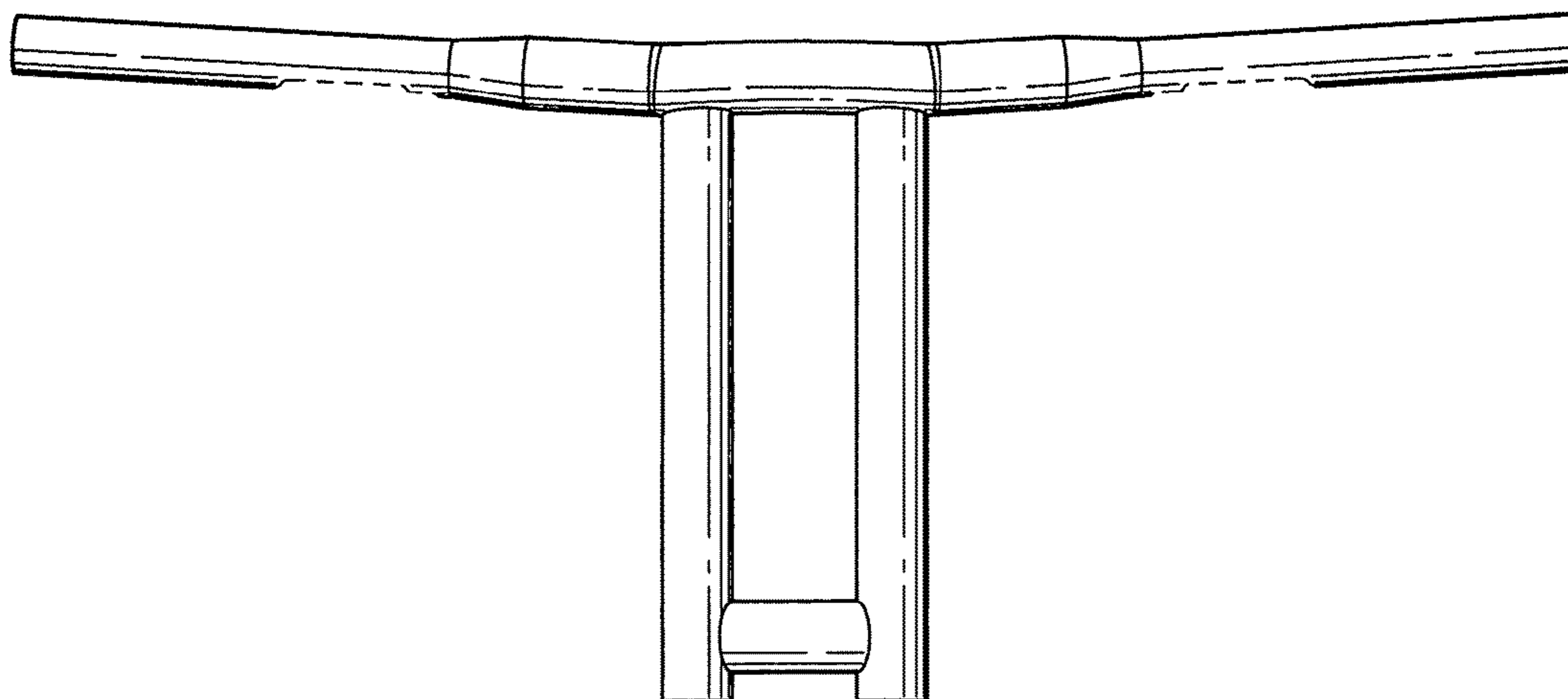

FIG. 11

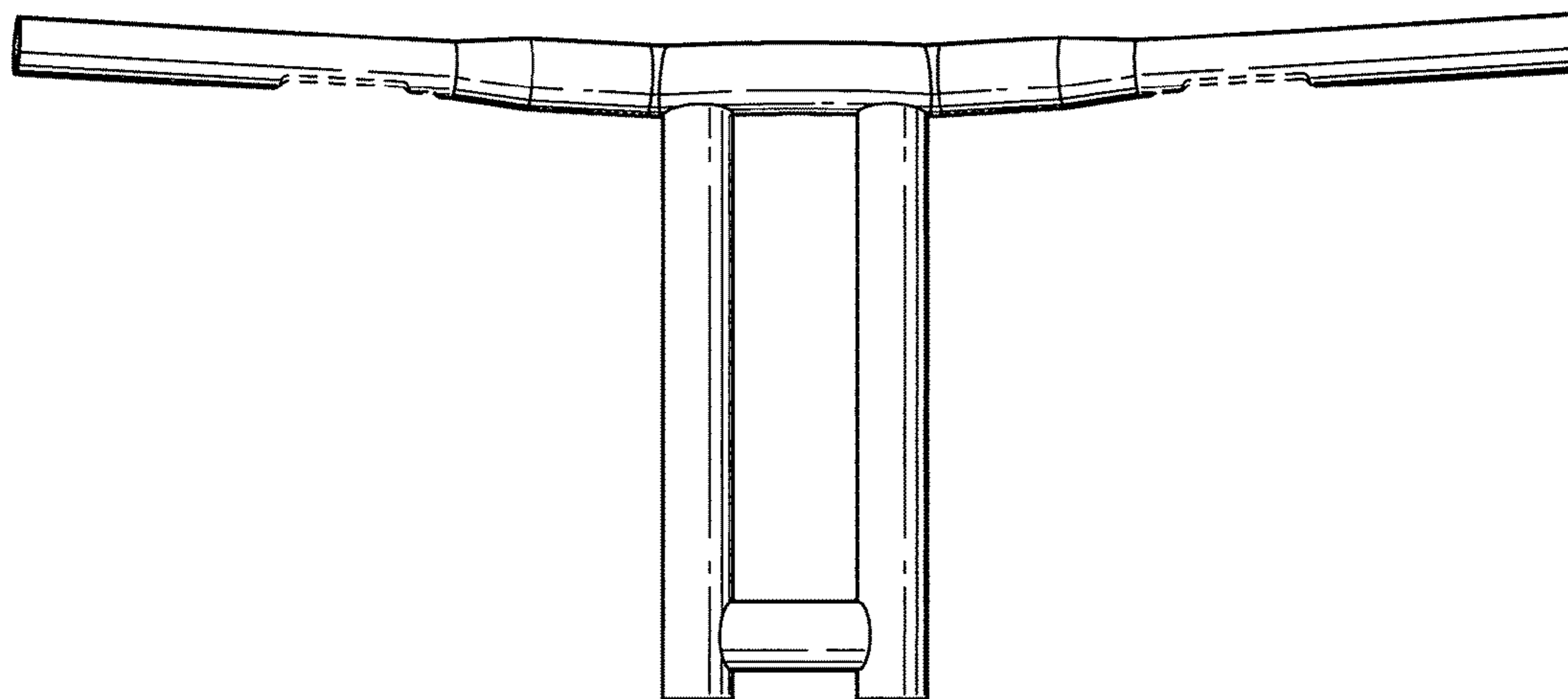

FIG. 12

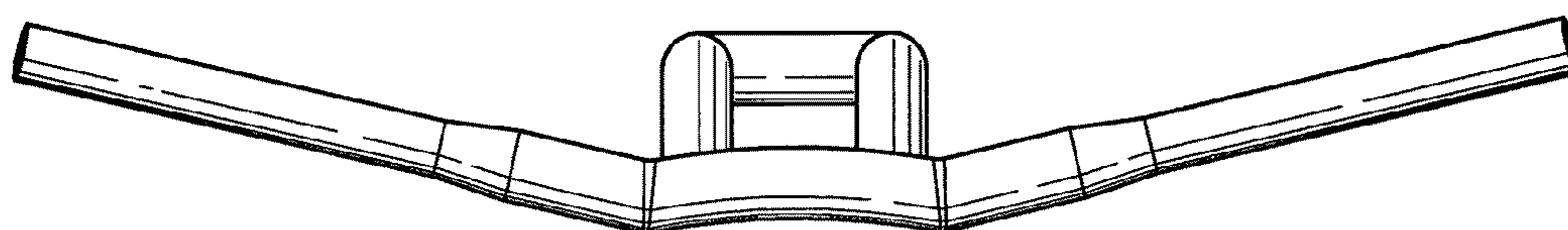

FIG. 13

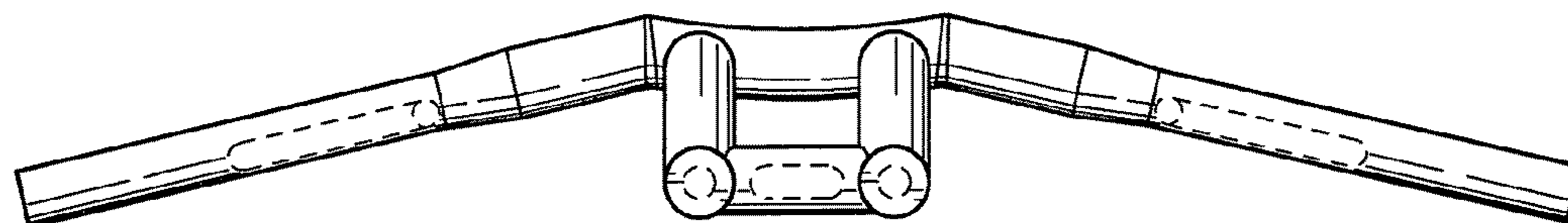

FIG. 14

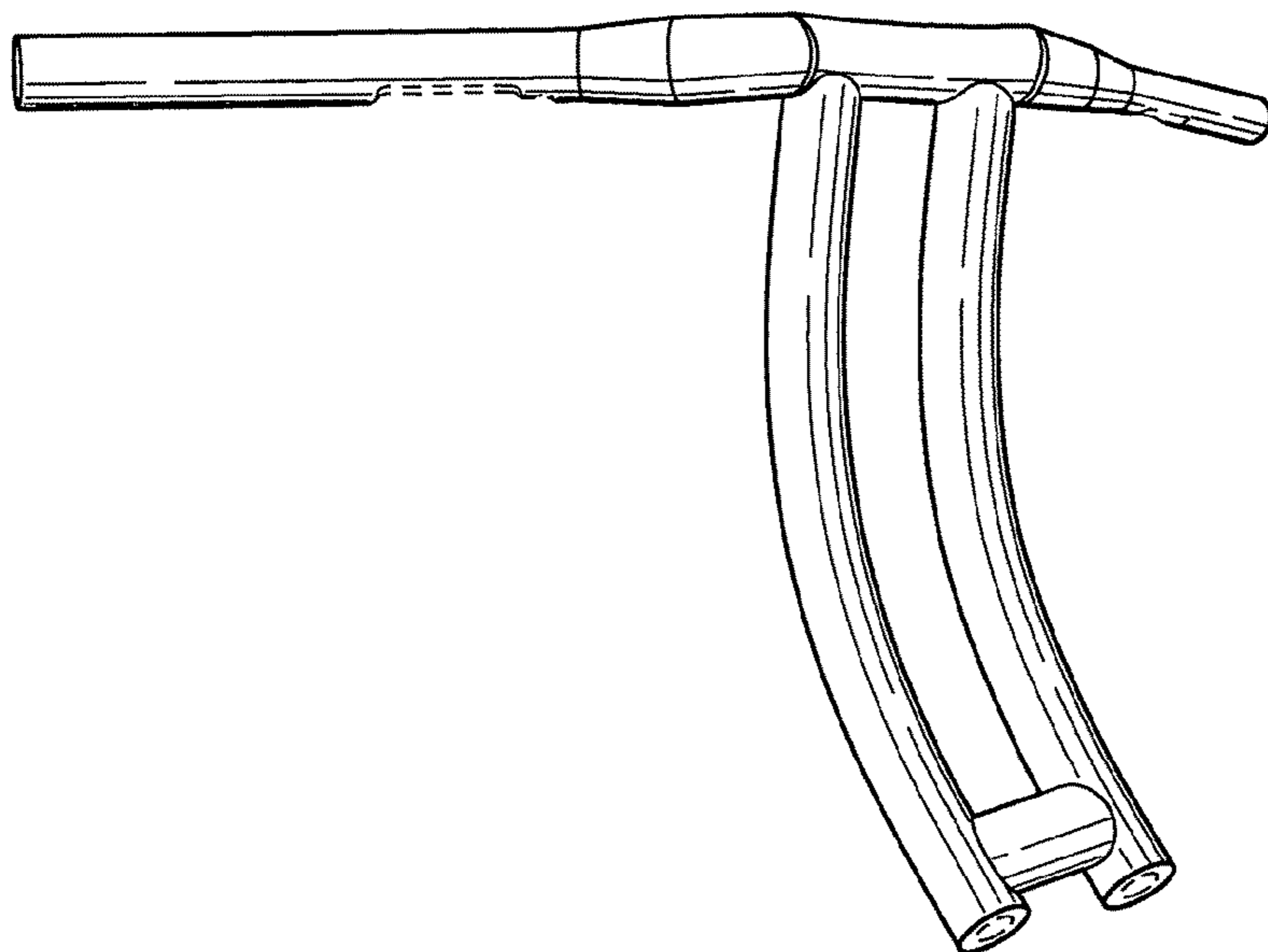

FIG. 15

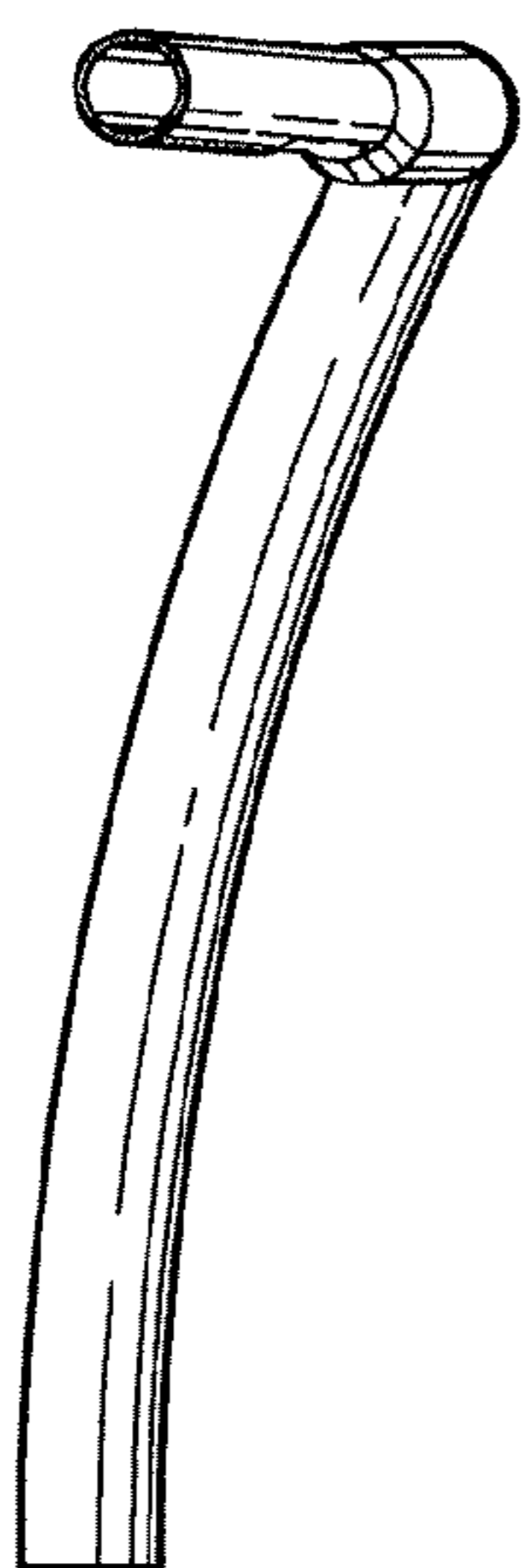

FIG. 16



FIG. 17

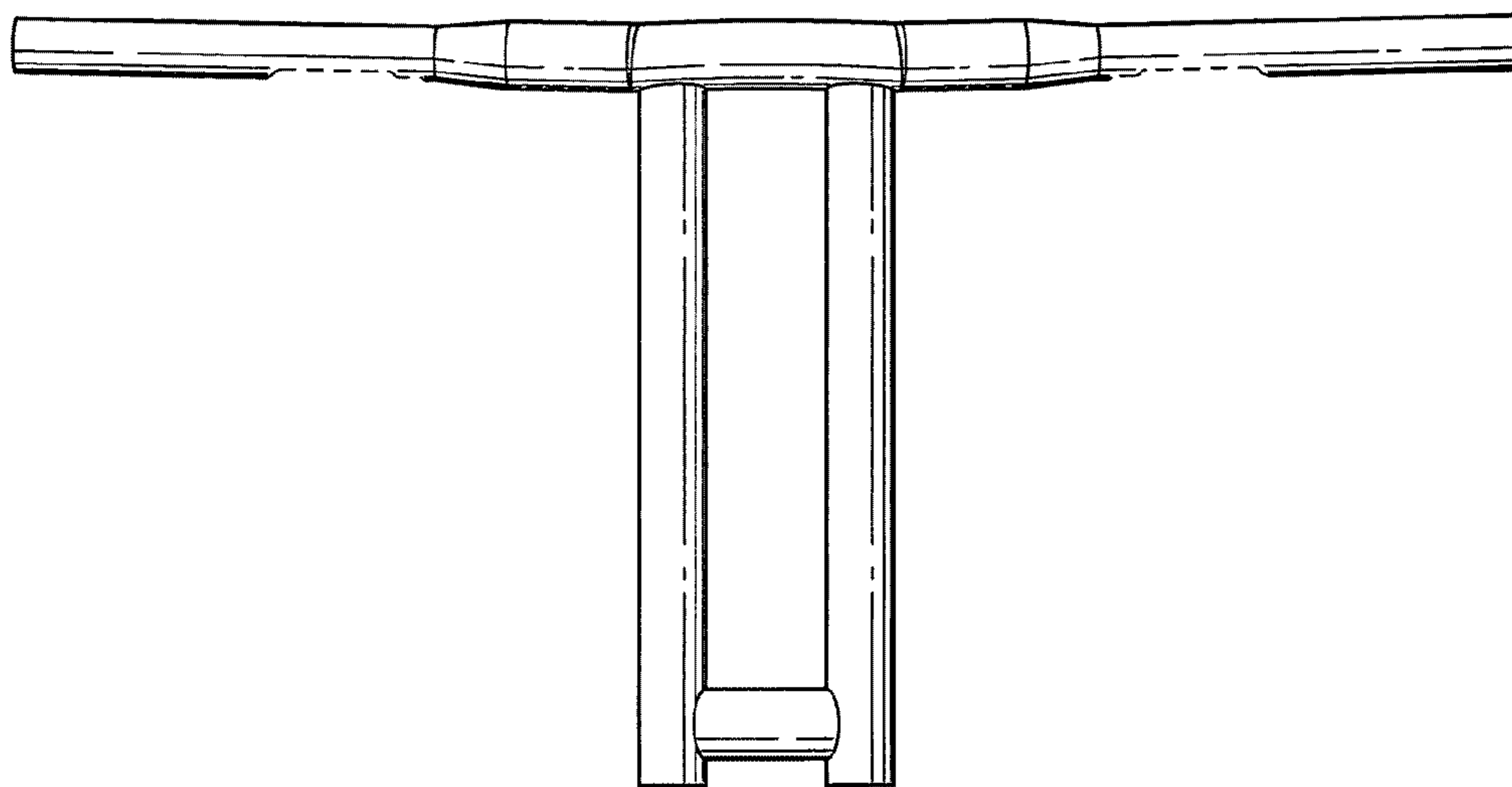

FIG. 18

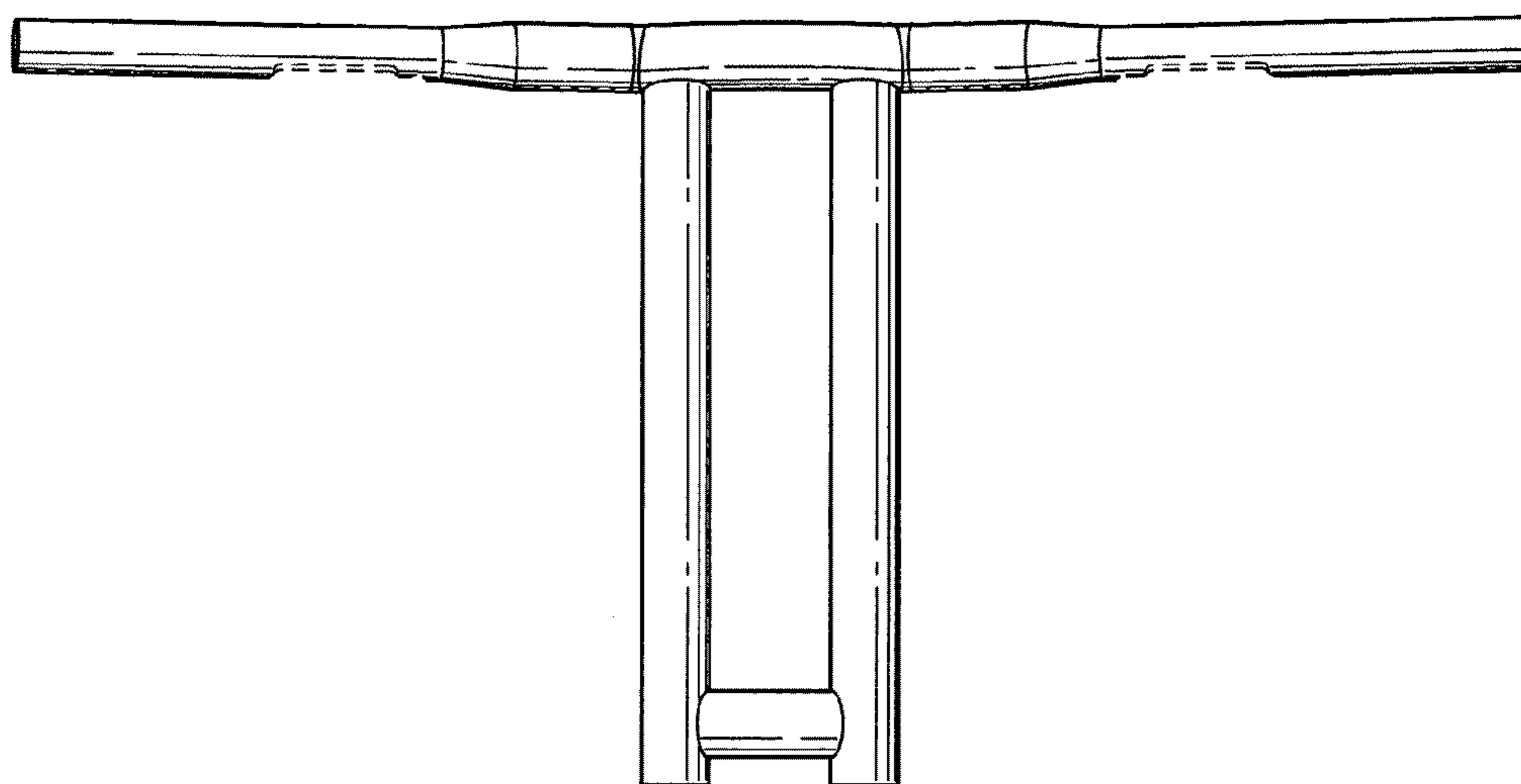

FIG. 19

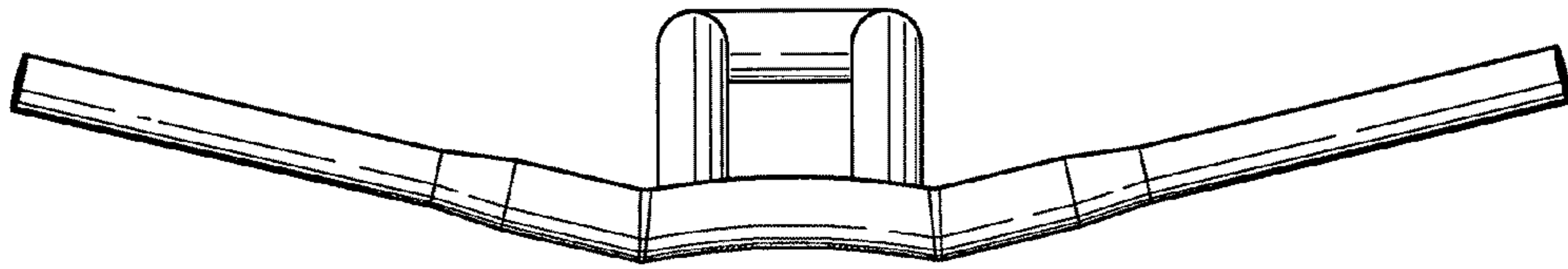

FIG. 20

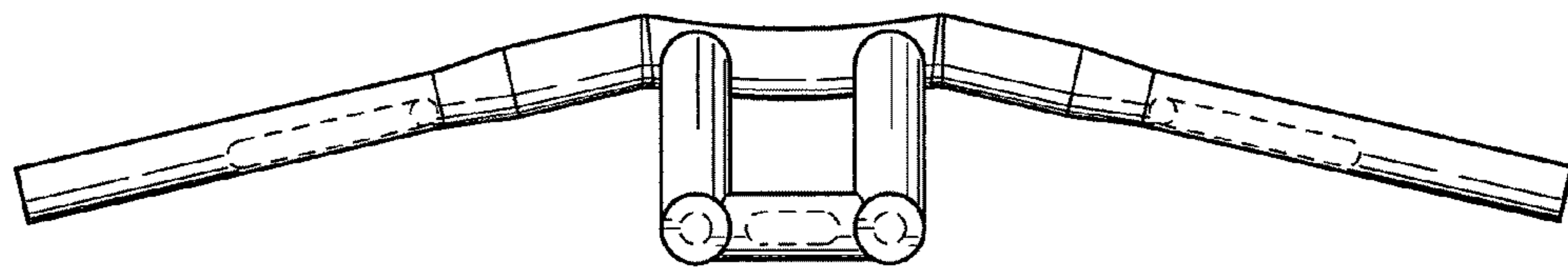

FIG. 21