



US00D725361S

(12) **United States Design Patent**
Osorio

(10) **Patent No.:** **US D725,361 S**
(45) **Date of Patent:** **** Mar. 31, 2015**

(54) **STRAP ARRANGEMENT**

(71) Applicant: **Aquazzura Italia SRL**, Florence (IT)

(72) Inventor: **Edgardo Osorio**, Florence (IT)

(73) Assignee: **Aquazzura Italia SRL**, Florence (IT)

(**) Term: **14 Years**

(21) Appl. No.: **29/488,438**

(22) Filed: **Apr. 18, 2014**

(51) **LOC (10) Cl.** **02-99**

(52) **U.S. Cl.**
USPC **D2/971**

(58) **Field of Classification Search**
USPC D2/896, 916–918, 925–942, 946,
D2/964–967, 969, 971; 36/1, 7.5–783, 8.1,
36/11.5, 45–58, 104, 108, 34 R–34 B
See application file for complete search history.

(56) **References Cited**

U.S. PATENT DOCUMENTS

D80,576 S *	2/1930	Morali	D2/935
D84,741 S *	7/1931	Grossman	D2/935
D84,742 S *	7/1931	Grossman	D2/935
D93,196 S *	9/1934	Benjamin	D2/931
D94,064 S *	12/1934	Arkin	D2/939
D94,437 S *	1/1935	Napier	D2/935
D94,450 S *	1/1935	Simon	D2/935
D95,491 S *	5/1935	Doring	D2/937
D95,887 S *	6/1935	Wood	D2/935
D492,096 S *	6/2004	Sanchez et al.	D2/926
D613,052 S *	4/2010	Guers-Neyraud	D2/971
D702,033 S *	4/2014	Zito	D2/971

* cited by examiner

Primary Examiner — Dominic Simone

(74) *Attorney, Agent, or Firm* — Leason Ellis LLP

(57) **CLAIM**

The ornamental design for a strap arrangement, as shown and described.

DESCRIPTION

FIG. 1 is a front perspective view of the strap arrangement showing features of my new design, in which portions of the shoe are illustrated as a first environment; FIG. 2 is a side view of FIG. 1; FIG. 3 is a rear view of FIG. 1; FIG. 4 is a front view of FIG. 1; FIG. 5 is a front view of FIG. 1, in which portions of the shoe now illustrate a second environment for my new design; FIG. 6 is a front view of FIG. 1, in which portions of the shoe now illustrate a third environment for my new design; and, FIG. 7 is a side view of FIG. 1, in which portions of the shoe now illustrate a fourth environment for my new design.

The dash-dot-dash broken lines define boundaries of the claimed design and form no part thereof. Meanwhile, the broken lines (dash-dash-dash) illustrate environmental structure and form no part of the claimed design.

A shoe lace of the claimed strap arrangement is shown broken away, in part, in FIGS. 1, 2 and 4 through 7, it being understood that the shoe lace has a uniform shape and appearance throughout its length. The appearance of any portion of the article between the break lines forms no part of the claimed design.

1 Claim, 7 Drawing Sheets

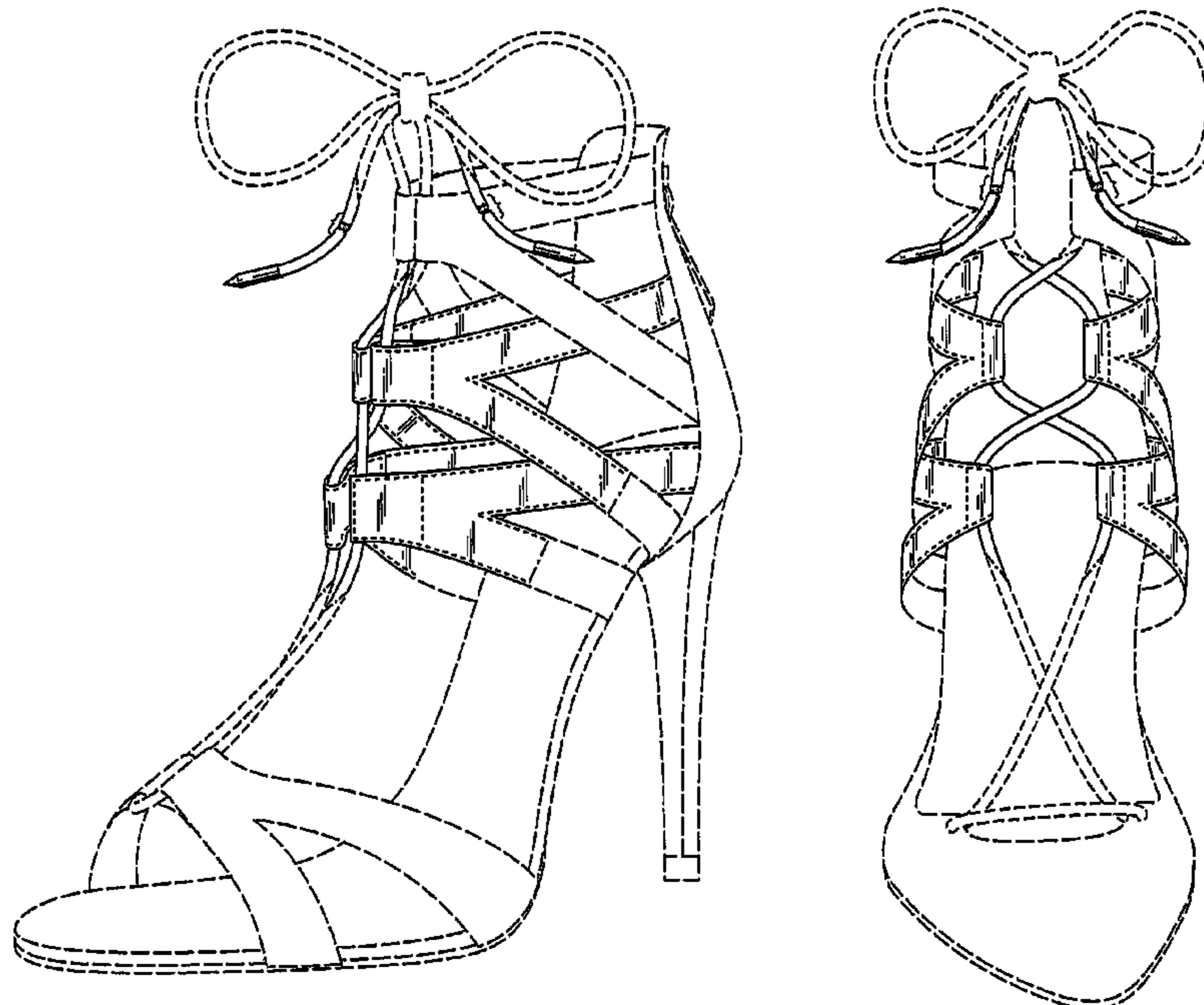

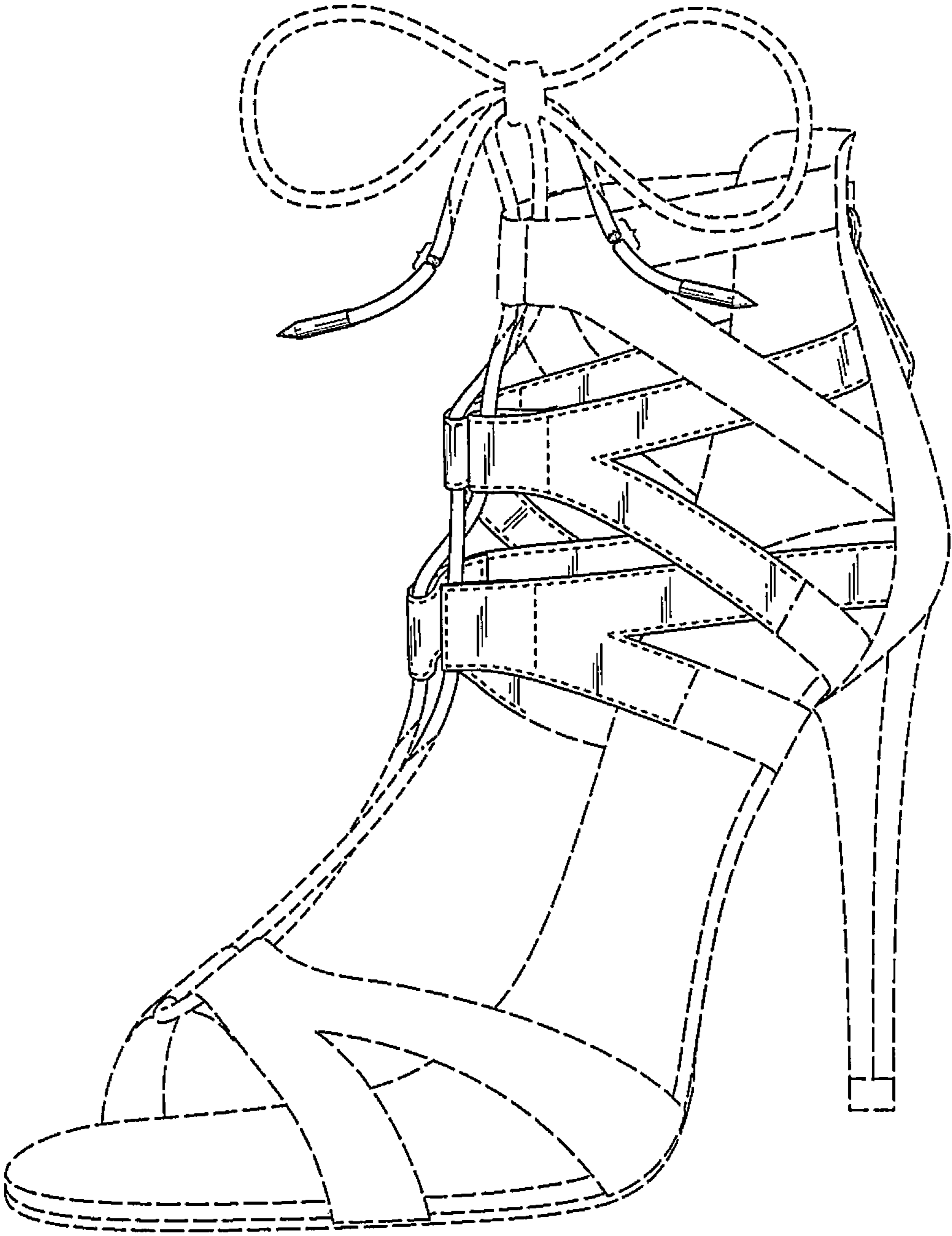

Fig. 1

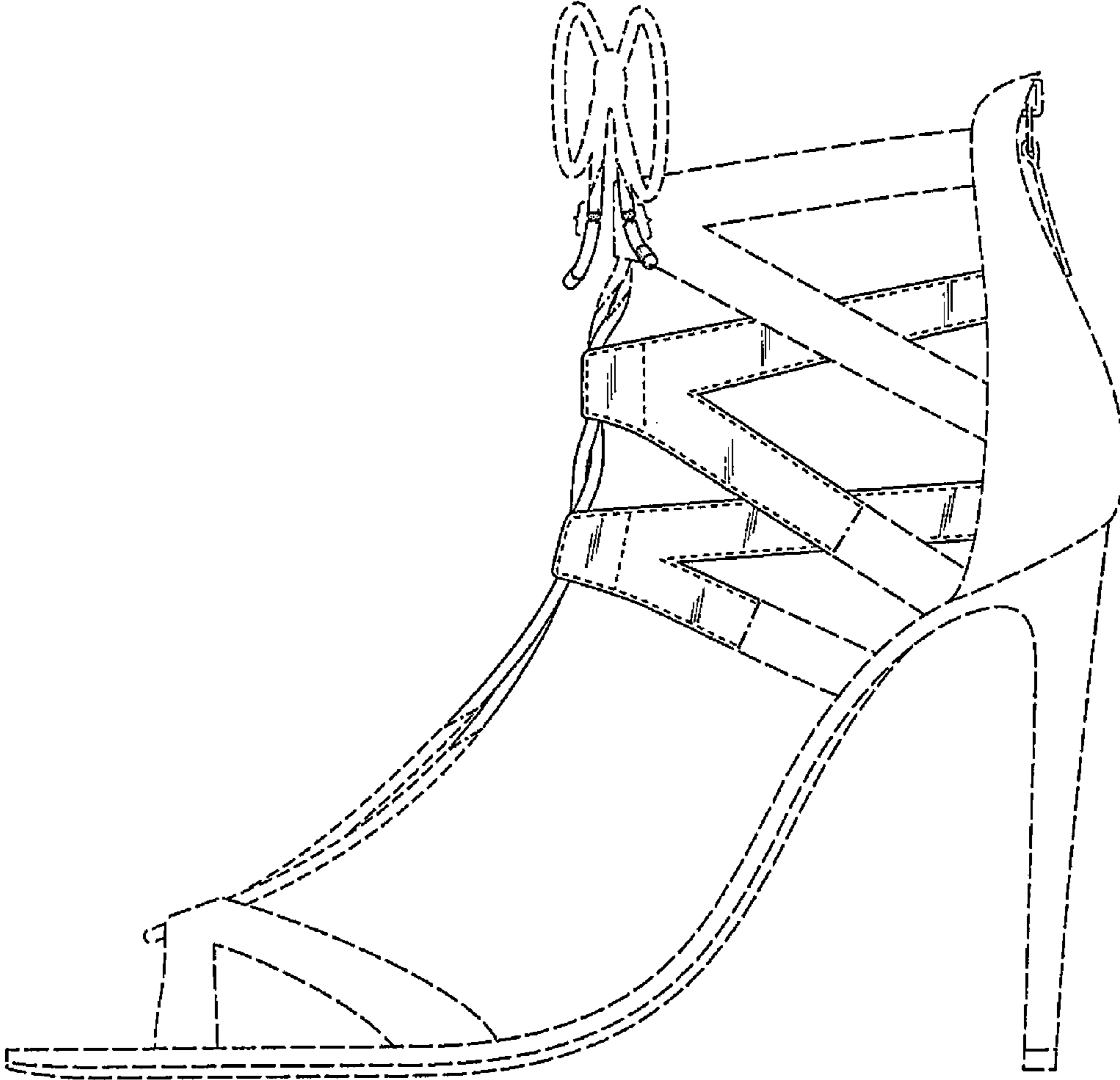

Fig. 2

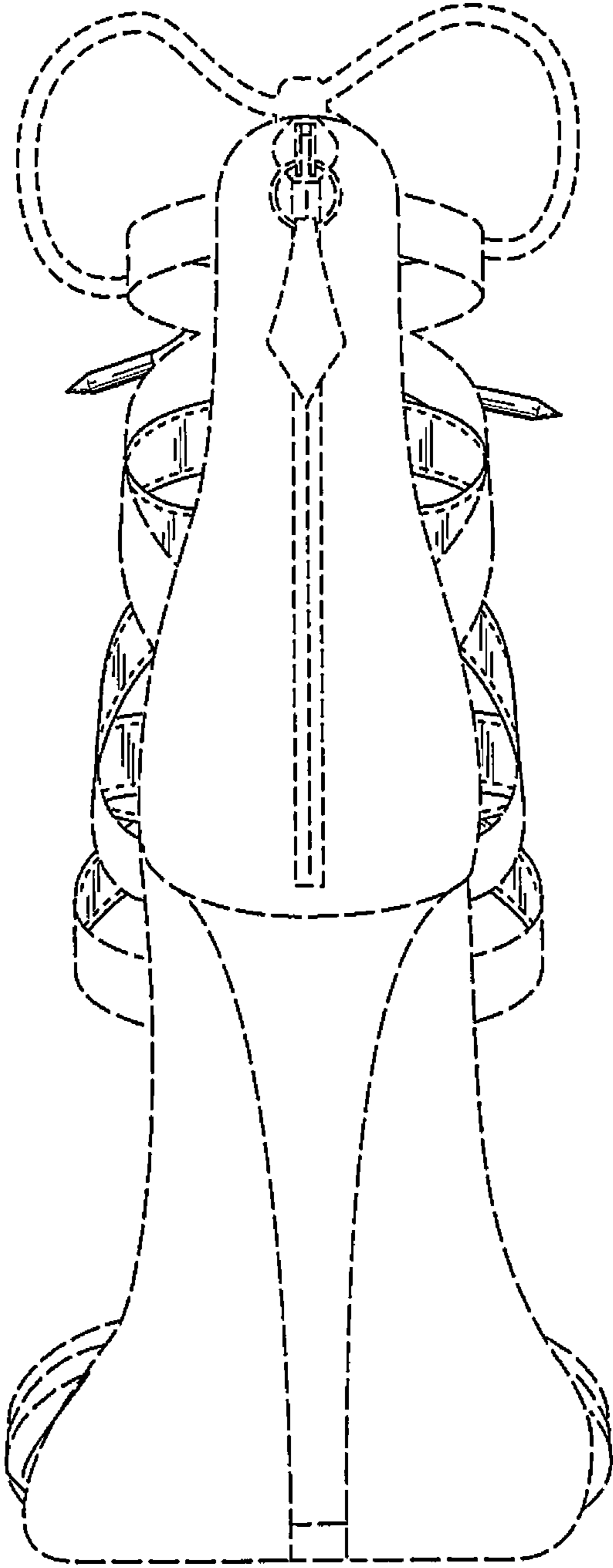

Fig. 3

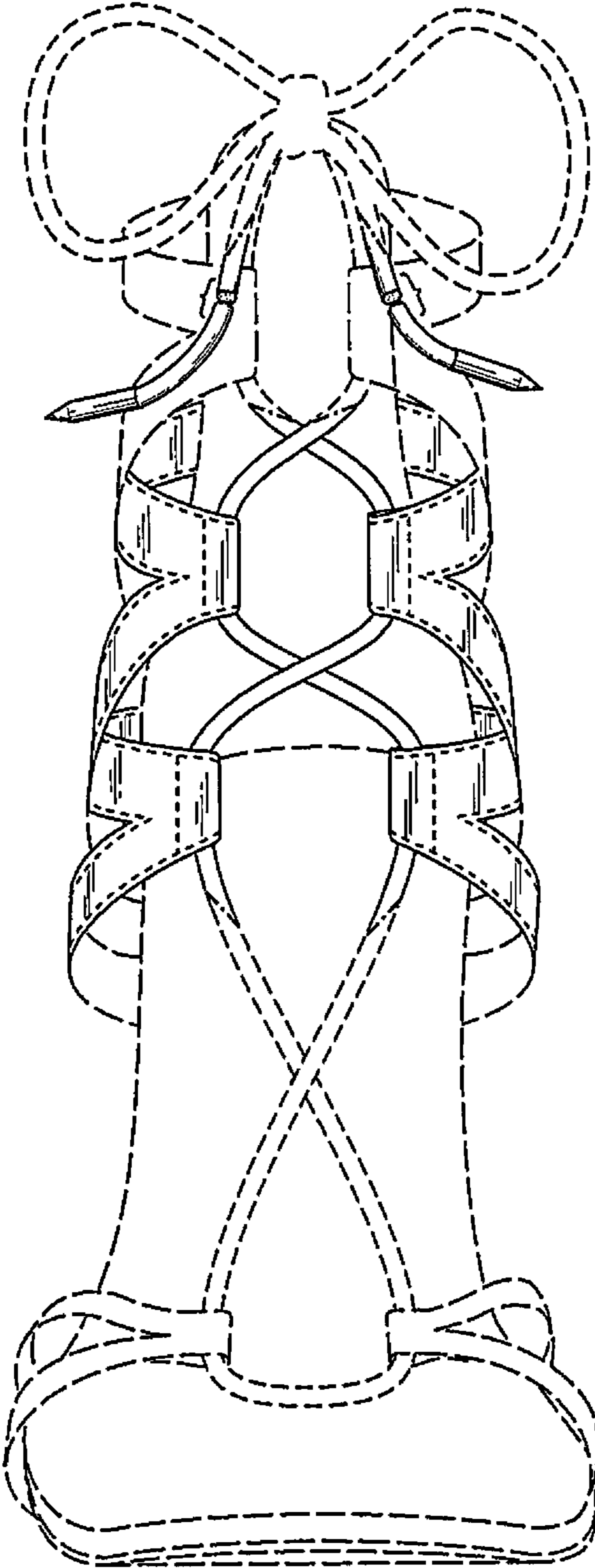

Fig. 4

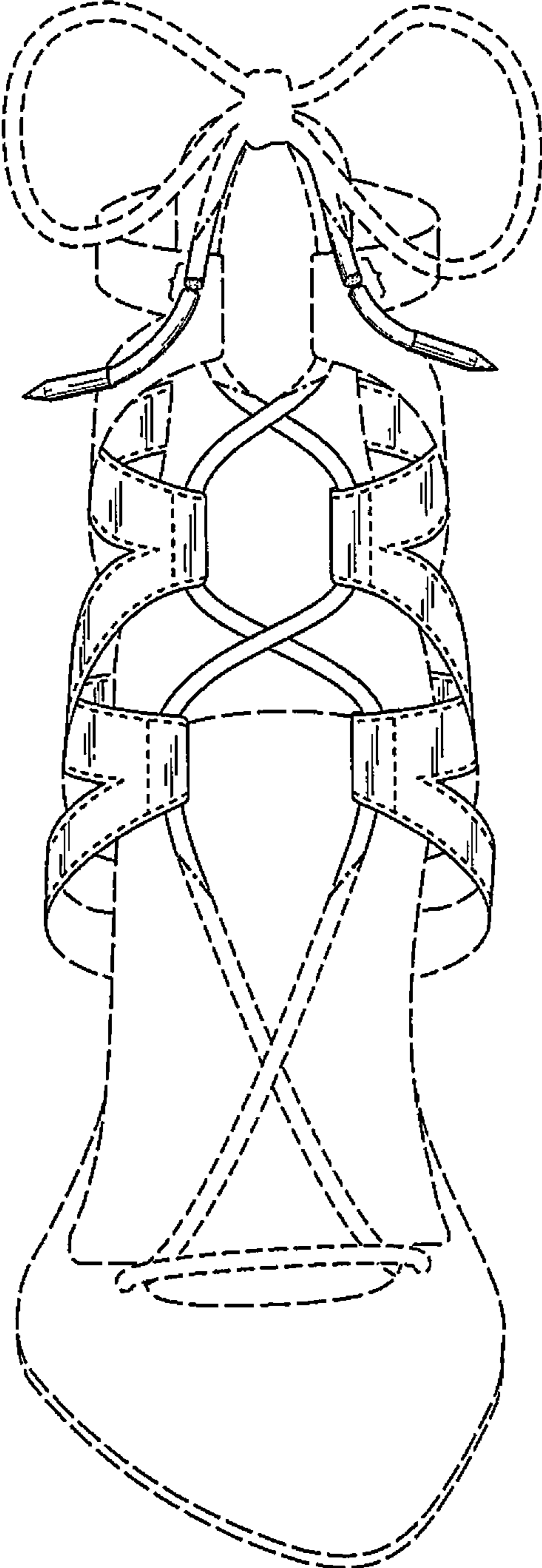

Fig. 5

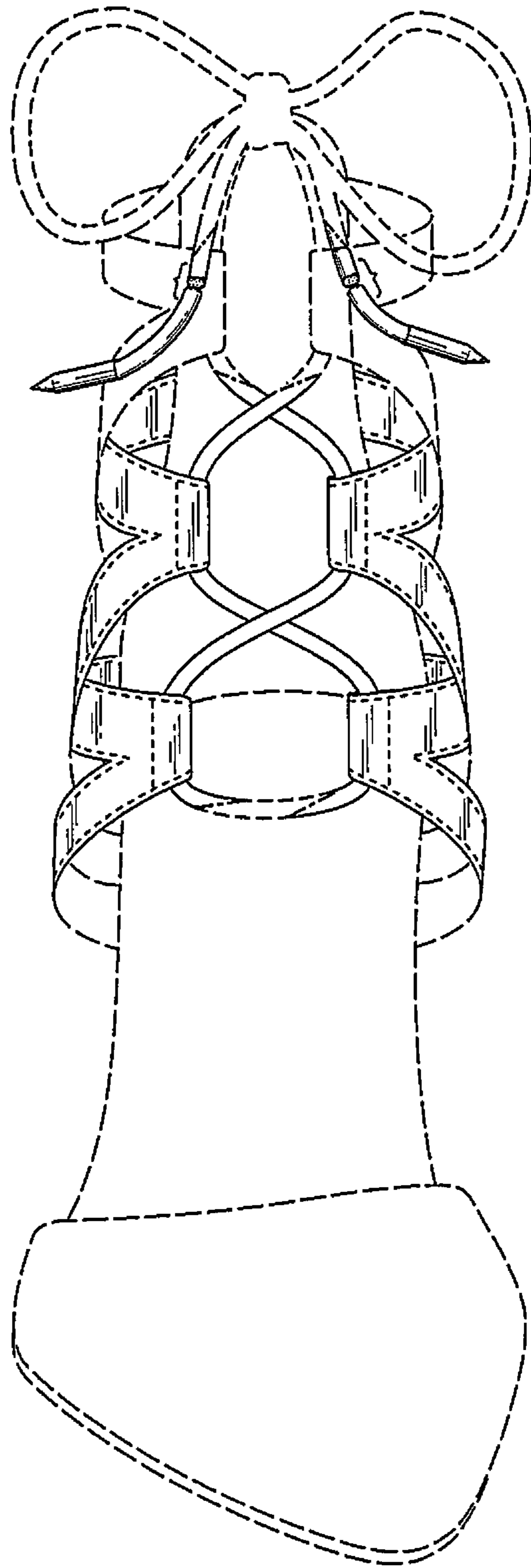

Fig. 6

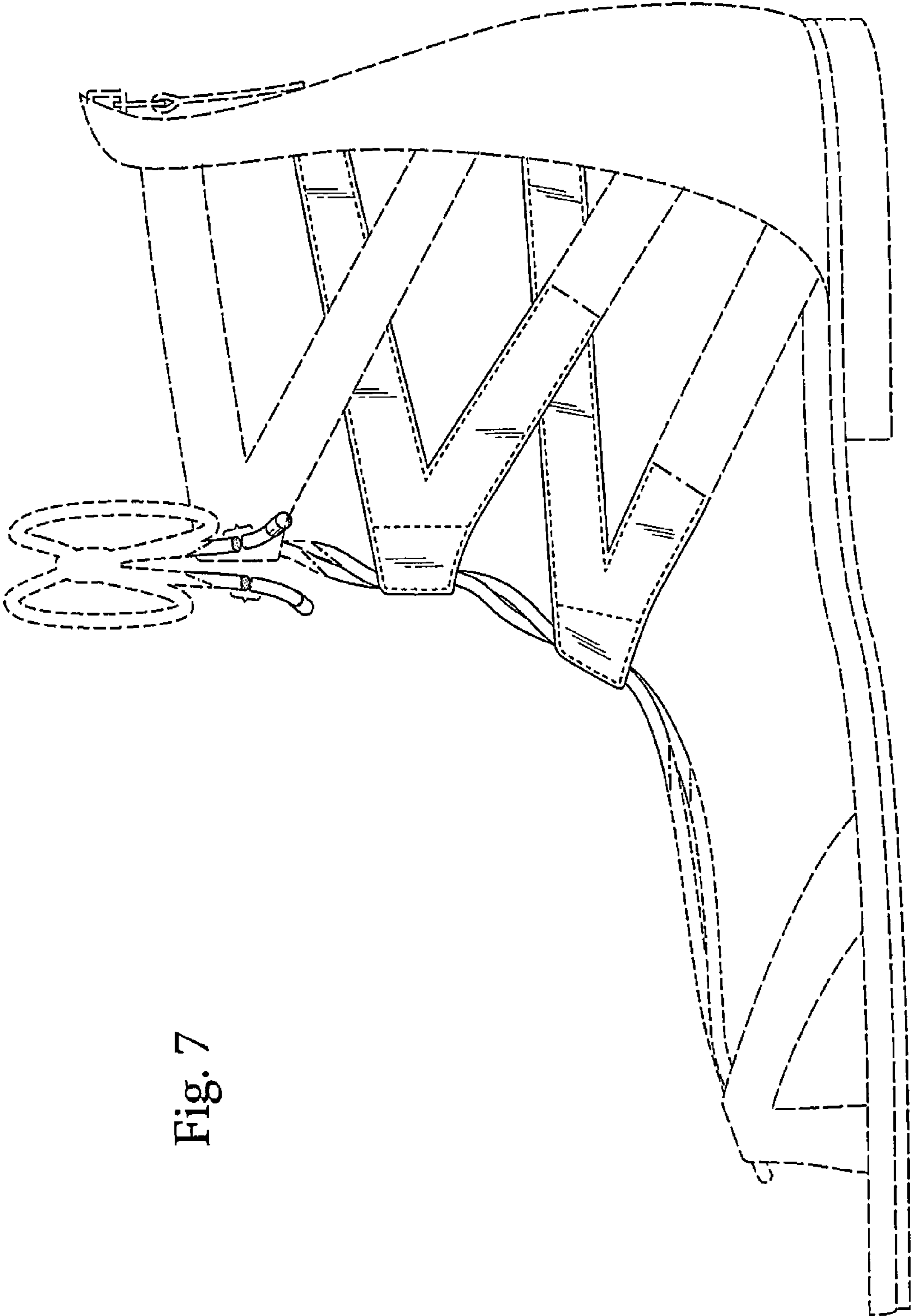

Fig. 7