



US00D725287S

(12) **United States Design Patent**
Allen

(10) **Patent No.:** **US D725,287 S**
(45) **Date of Patent:** **** Mar. 24, 2015**

(54) **SHOPPING CART CORRAL HAVING AN ENTRY PORTION TO WHICH ADVERTISEMENTS ARE AFFIXED**

FOREIGN PATENT DOCUMENTS

CA 2848905 3/2013
CN 203054922 7/2013

(71) Applicant: **Joseph Allen**, Murrieta, CA (US)

(Continued)

(72) Inventor: **Joseph Allen**, Murrieta, CA (US)

OTHER PUBLICATIONS

(73) Assignee: **Starlite Media, LLC**, New York, NY (US)

RFID Technology [online], [retrieved Feb. 14, 2014]. Retrieved from the Internet: <URL: <http://www.vorelco.com/services/rfid-technology>>, 16 pages.

(**) Term: **14 Years**

(Continued)

(21) Appl. No.: **29/432,660**

Primary Examiner — Garth Rademaker

(22) Filed: **Sep. 18, 2012**

Assistant Examiner — Samantha Q Lawrence

(74) *Attorney, Agent, or Firm* — Bryan Cave LLP

Related U.S. Application Data

(60) Division of application No. 29/405,487, filed on Nov. 2, 2011, now Pat. No. Des. 667,504, which is a continuation of application No. 29/387,041, filed on Mar. 8, 2011, now Pat. No. Des. 653,709, which is a continuation of application No. 29/364,404, filed on Jun. 23, 2010, now abandoned, which is a continuation of application No. 29/314,253, filed on Mar. 17, 2009, now abandoned.

(57) **CLAIM**

The ornamental design for a shopping cart corral having an entry portion to which advertisements are affixed, as shown and described.

(51) **LOC (10) Cl.** **25-03**

(52) **U.S. Cl.**
USPC **D25/22**

(58) **Field of Classification Search**
USPC D25/1-33; 52/36.1, 79.1-79.5, 169.6, 52/80.1, 80.2, 90.1, 90.2, 91.1, 91.2, 91.3, 52/92.1-92.3, 93.1, 93.2; D20/10, 17-19, D20/39, 41-43, 99; 211/17; 256/25
See application file for complete search history.

DESCRIPTION

FIG. 1 is a top isometric view of a roofed shopping cart corral having an entry portion to which advertisements may be affixed;
FIG. 2 is a side view thereof;
FIG. 3 is a front view thereof;
FIG. 4 is a top view thereof;
FIG. 5 is a top isometric view of a roofed shopping cart corral having an entry portion to which advertisements may be affixed;
FIG. 6 is a side view thereof;
FIG. 7 is a front view thereof; and,
FIG. 8 is a top view thereof.
The broken lines depict portions of the shopping cart corral having an entry portion to which advertisements are affixed which form no part of the claimed design.

(56) **References Cited**

U.S. PATENT DOCUMENTS

D31,832 S 11/1899 Marcus
1,927,997 A 9/1933 Weston
2,165,724 A 7/1939 Page et al.
2,985,316 A 5/1961 Ruhnke

(Continued)

1 Claim, 8 Drawing Sheets

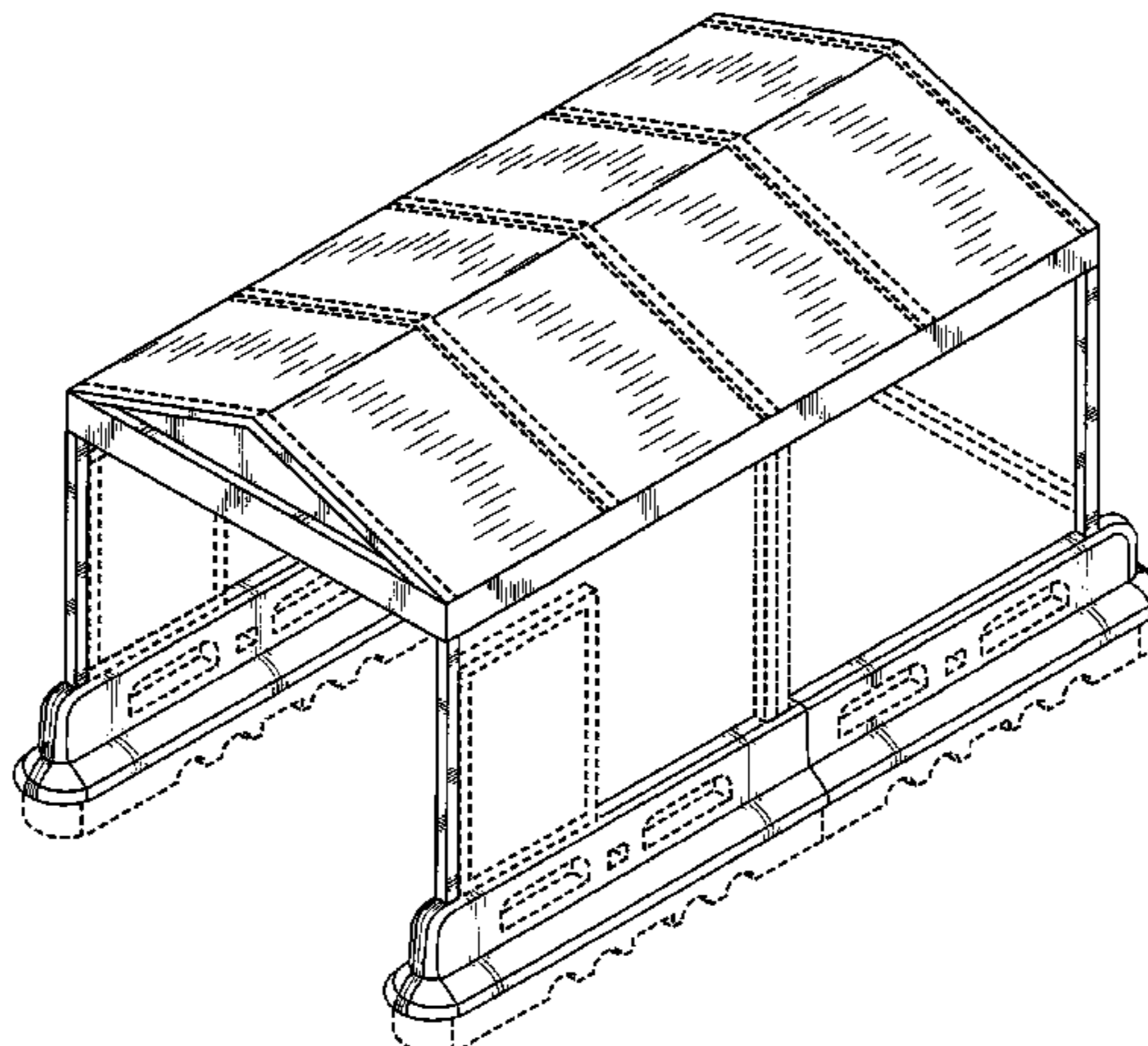

(56)

References Cited

U.S. PATENT DOCUMENTS

3,323,655 A 6/1967 Foran et al.
D219,946 S 2/1971 Birnberg
3,722,702 A 3/1973 Marker, Jr.
4,236,697 A 12/1980 Savino
4,292,352 A 9/1981 Singer
4,364,192 A 12/1982 Lloyd
D269,978 S 8/1983 Dickson
4,609,183 A 9/1986 Ulmer
D286,074 S 10/1986 Corte
4,777,750 A 10/1988 Garfinkle
4,884,353 A 12/1989 Taylor
4,918,878 A 4/1990 Paschke et al.
4,957,256 A 9/1990 Boeding
D321,798 S 11/1991 Buckley
D334,301 S 3/1993 Buckley
5,201,426 A 4/1993 Cruwell
5,220,740 A 6/1993 Brault
5,279,085 A 1/1994 DiPaolo et al.
D350,038 S 8/1994 Buckley
D361,448 S 8/1995 Buckley
5,551,578 A 9/1996 McCue et al.
D376,854 S 12/1996 DiPaolo et al.
5,626,926 A 5/1997 Roberts
5,862,921 A 1/1999 Venegas
5,875,578 A 3/1999 Grewe
5,878,518 A 3/1999 Grewe
6,298,997 B1 10/2001 Jarrett et al.
6,449,888 B1 9/2002 Gibbs
6,493,997 B2 12/2002 Cohen
6,581,616 B1 6/2003 Venegas
D488,904 S 4/2004 Unnerstall et al.
D492,732 S 7/2004 Herbst
D495,011 S 8/2004 Trubiano
D497,167 S 10/2004 Ozolins et al.
6,975,205 B1 12/2005 French et al.
7,044,446 B2 5/2006 Hempen et al.
7,140,581 B1 11/2006 White
D537,952 S 3/2007 Anton
D540,472 S 4/2007 Van Es
7,210,270 B1 5/2007 King et al
7,237,360 B2 7/2007 Moncho et al.
D587,761 S 3/2009 Grimshaw
D588,201 S 3/2009 Kohagen et al.
7,660,747 B2 2/2010 Brice et al.
D615,129 S 5/2010 Allen
D620,531 S 7/2010 Allen
7,895,782 B2 3/2011 Farrell
8,015,737 B2 9/2011 Venegas, Jr.
8,104,671 B2 1/2012 Besecker et al.
D653,709 S 2/2012 Allen
RE43,233 E 3/2012 Venegas, Jr.
8,205,757 B2 6/2012 Allen
D663,779 S 7/2012 Lueken
D667,504 S 9/2012 Allen
8,332,272 B2 12/2012 Fisher
8,424,690 B2 4/2013 Allen
D682,944 S 5/2013 Lueken
D695,835 S * 12/2013 Lueken D20/19
D695,836 S * 12/2013 Lueken D20/19
D695,837 S * 12/2013 Lueken D20/19
D699,789 S * 2/2014 Allen D20/19
D701,322 S * 3/2014 McCue et al. D25/32
D703,271 S * 4/2014 Lueken D20/19
2004/0079934 A1 4/2004 Hempen et al.

2008/0040962 A1 2/2008 Gurren
2008/0120877 A1 5/2008 Farrell
2010/0114683 A1 5/2010 Wessels et al.
2010/0327245 A1 12/2010 Allen
2011/0047023 A1 2/2011 Lieblang et al.
2011/0218942 A1 9/2011 Scheffer
2012/0029998 A1 2/2012 Aversano et al.
2012/0066068 A1 3/2012 Pan
2012/0123826 A1 5/2012 French et al.
2012/0209686 A1 8/2012 Horowitz et al.
2012/0271715 A1 10/2012 Morton et al.
2013/0085835 A1 4/2013 Horowitz
2013/0090999 A1 4/2013 Lellouche
2013/0091002 A1 4/2013 Christie et al.
2013/0159090 A1 6/2013 Boal
2013/0204697 A1 8/2013 Boal
2013/0332253 A1 12/2013 Shiffert et al.
2013/0332258 A1 12/2013 Shiffert et al.
2013/0332274 A1 12/2013 Faith et al.
2013/0332283 A1 12/2013 Faith et al.
2014/0108108 A1 4/2014 Artman et al.

FOREIGN PATENT DOCUMENTS

EP 2273444 1/2011
EP 2487875 8/2012
WO WO 2013/040591 3/2013
WO WO 2013/126894 8/2013

OTHER PUBLICATIONS

Thinaire Launches the First Ever NFC Enterprise Marketing Platform [online], Sep. 12, 2012, [retrieved Jul. 31, 2014]. Retrieved from the Internet <URL: <http://globenewswire.com/news-release/2012/09/12/490308/10004878/en/Thinaire-TM-Launches-the-First-Ever-NFC-Enterprise-Marketing-Platform.html>>.
Kraft NFC pilot delivers 12 times the engagement level of QR codes [online], Oct. 18, 2012, [retrieved Jul. 31, 2014]. Retrieved from the Internet <URL: <http://www.mobilecommercedaily.com/kraft-nfc-pilot-delivers-12-times-the-engagement-level-of-qr-codes>>.
Valassis Launches Electronic Coupon Clearing Platform [online], Oct. 20, 2011, [retrieved Jul. 31, 2014]. Retrieved from the Internet <URL: <http://news.thomasnet.com/fullstory/Coupon-Redemption-Software-performs-real-time-validation-604347>>.
RFID-Enabled Cart Set to Provide Shoppers With Product Info, Ads [online], Jan. 31, 2007, [retrieved Jul. 31, 2014]. Retrieved from the Internet <URL: <http://rfidjournal.com/articles/view?3013>>.
Meijer's Smart Carts [online], Nov. 8, 2006, [retrieved Jul. 31, 2014]. Retrieved from the Internet <URL: <http://www.retailwire.com/discussion/11786/meijers-smart-carts>>.
Store logistics and payment with NFC [online], Jul. 1, 2006, [retrieved Jul. 31, 2014]. Retrieved from the Internet <URL: <http://www.ist-world.org/ProjectDetails.aspx?ProjectId=e89323fb585a4b798bf211f044c71b54&SourceDatabaseId=7cff9226e582440894200b751bab883f>>.
Stop & Shop, Scan It! & Scan It! Mobile [online], [retrieved Aug. 1, 2014]. Retrieved from the Internet <URL: <http://www.stopandshop.com/scanitmobile>>.
Brand.net brochure, Mobile Ads: Any Device / Instant Action, Apr. 2013.
Stop and Shop, Login [online], [retrieved Aug. 1, 2014]. Retrieved from the Internet <URL: https://www.stopandshop.com/login/?__requestid=88655>.

* cited by examiner

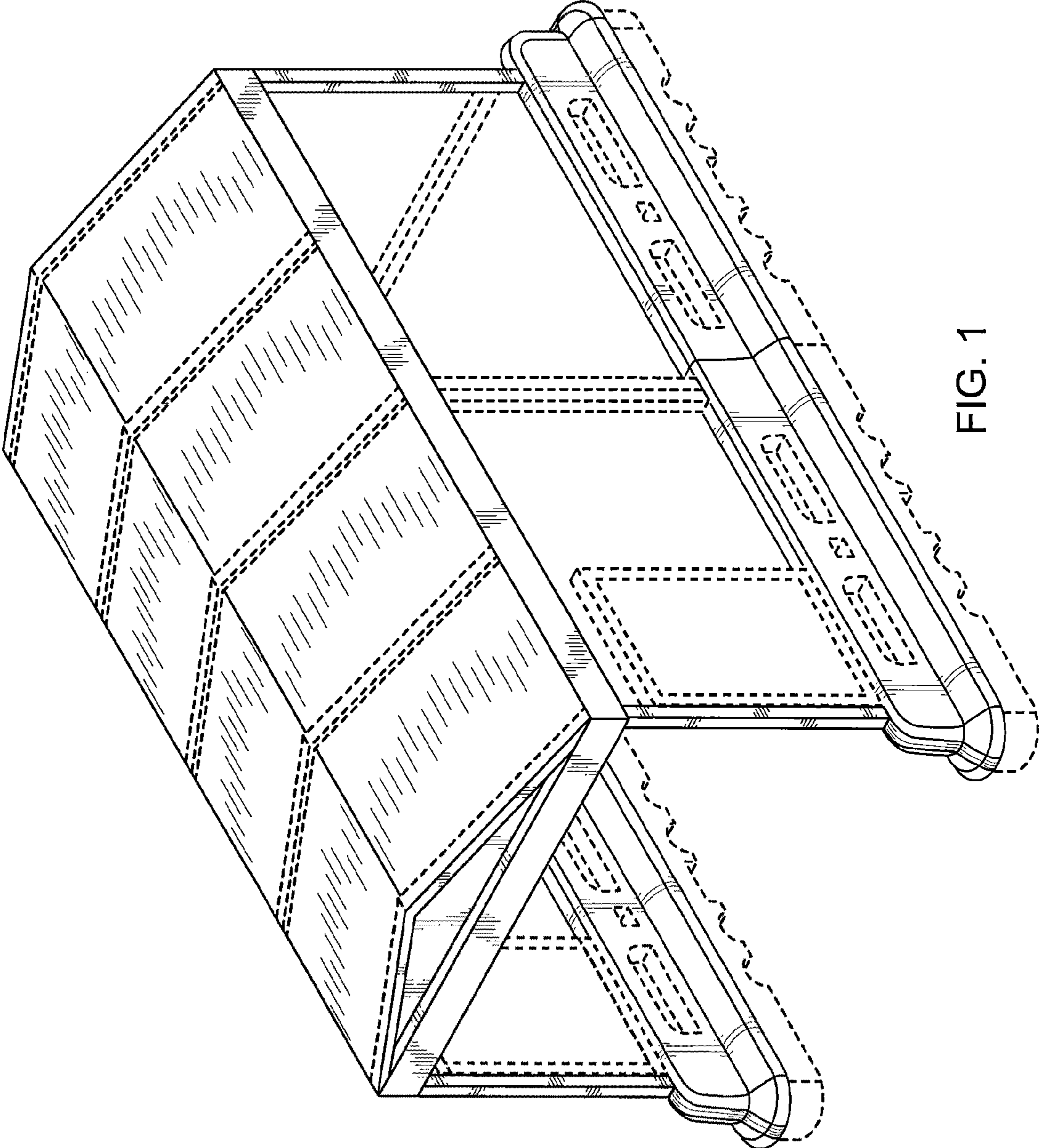

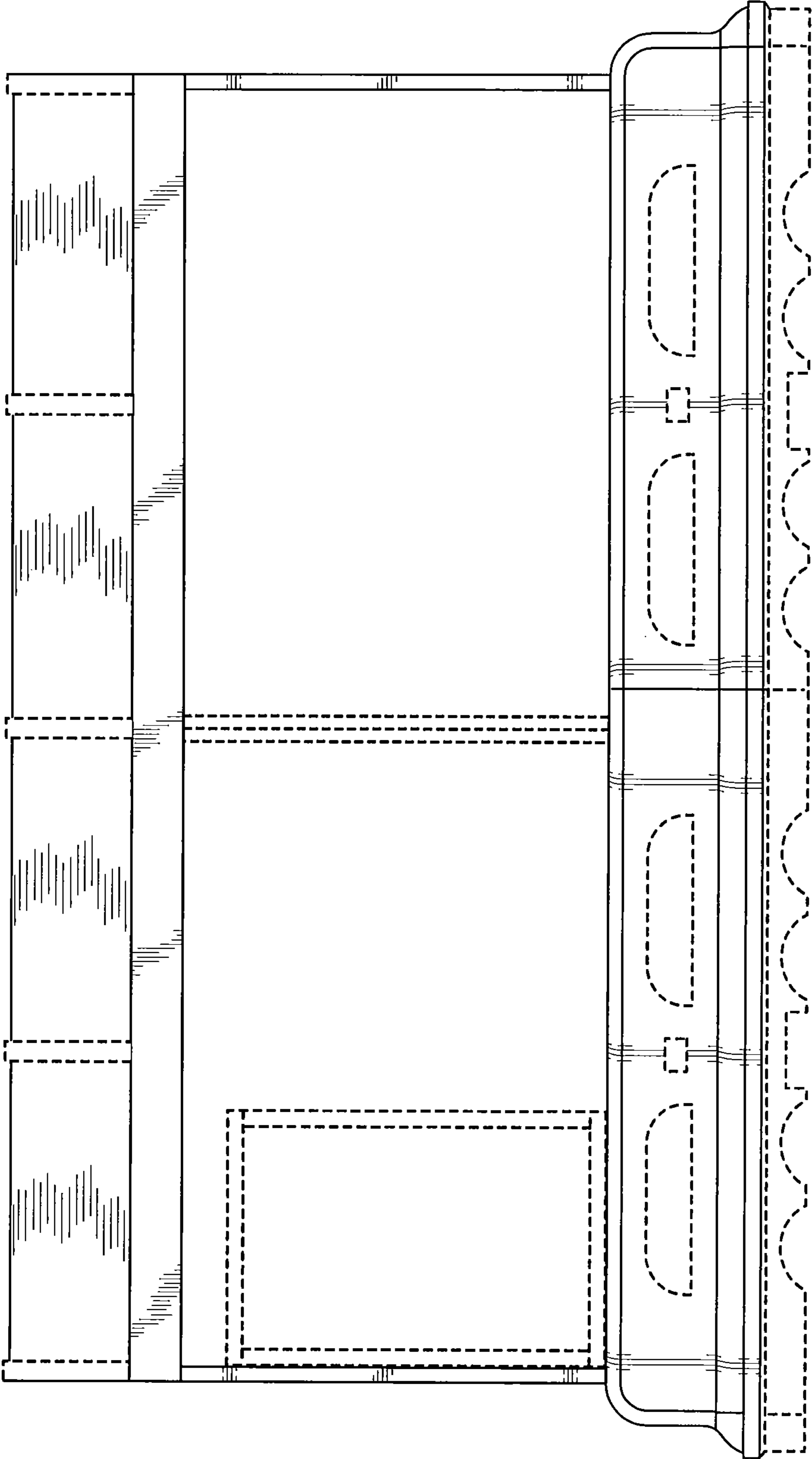

FIG. 2

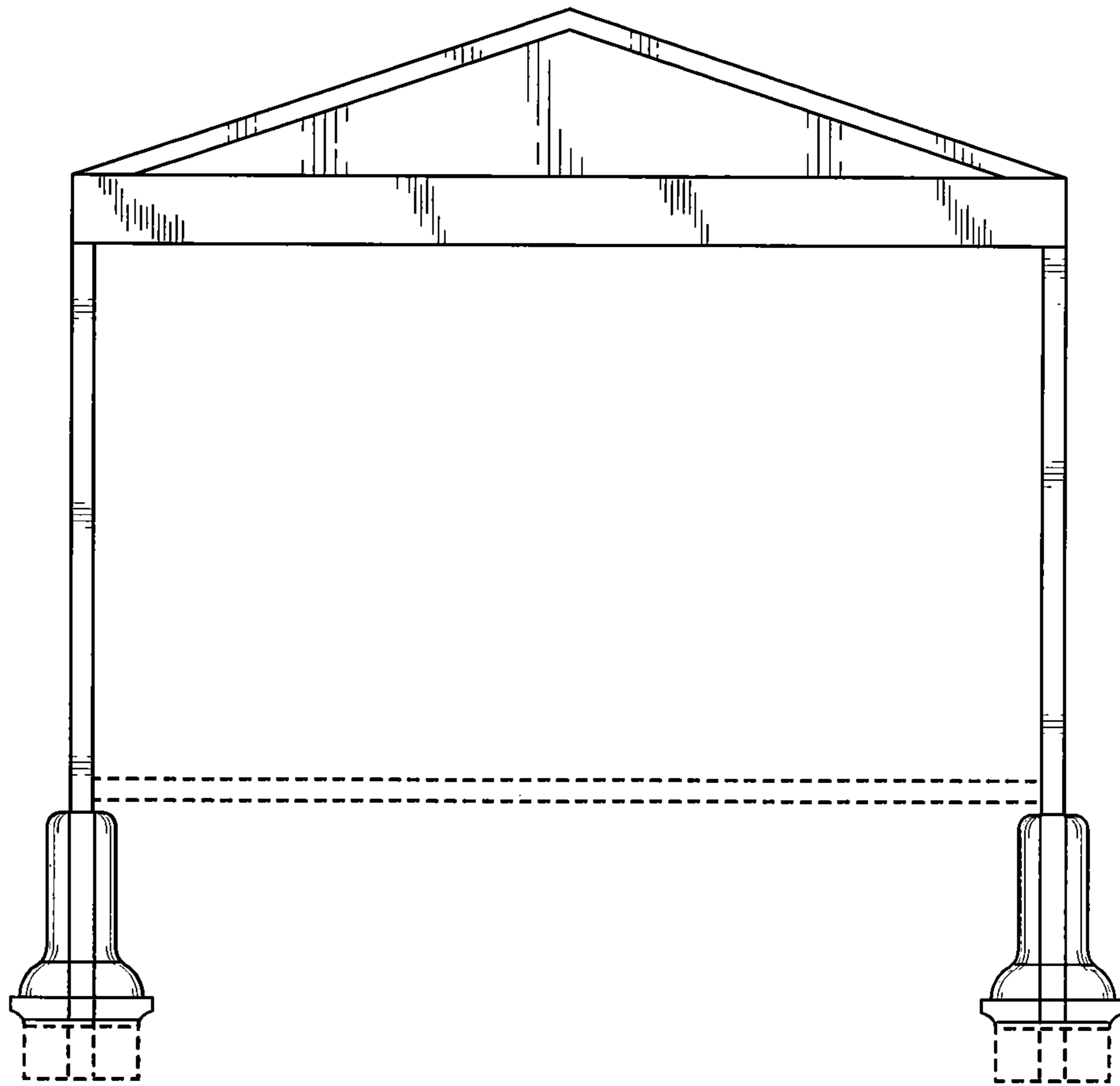

FIG. 3

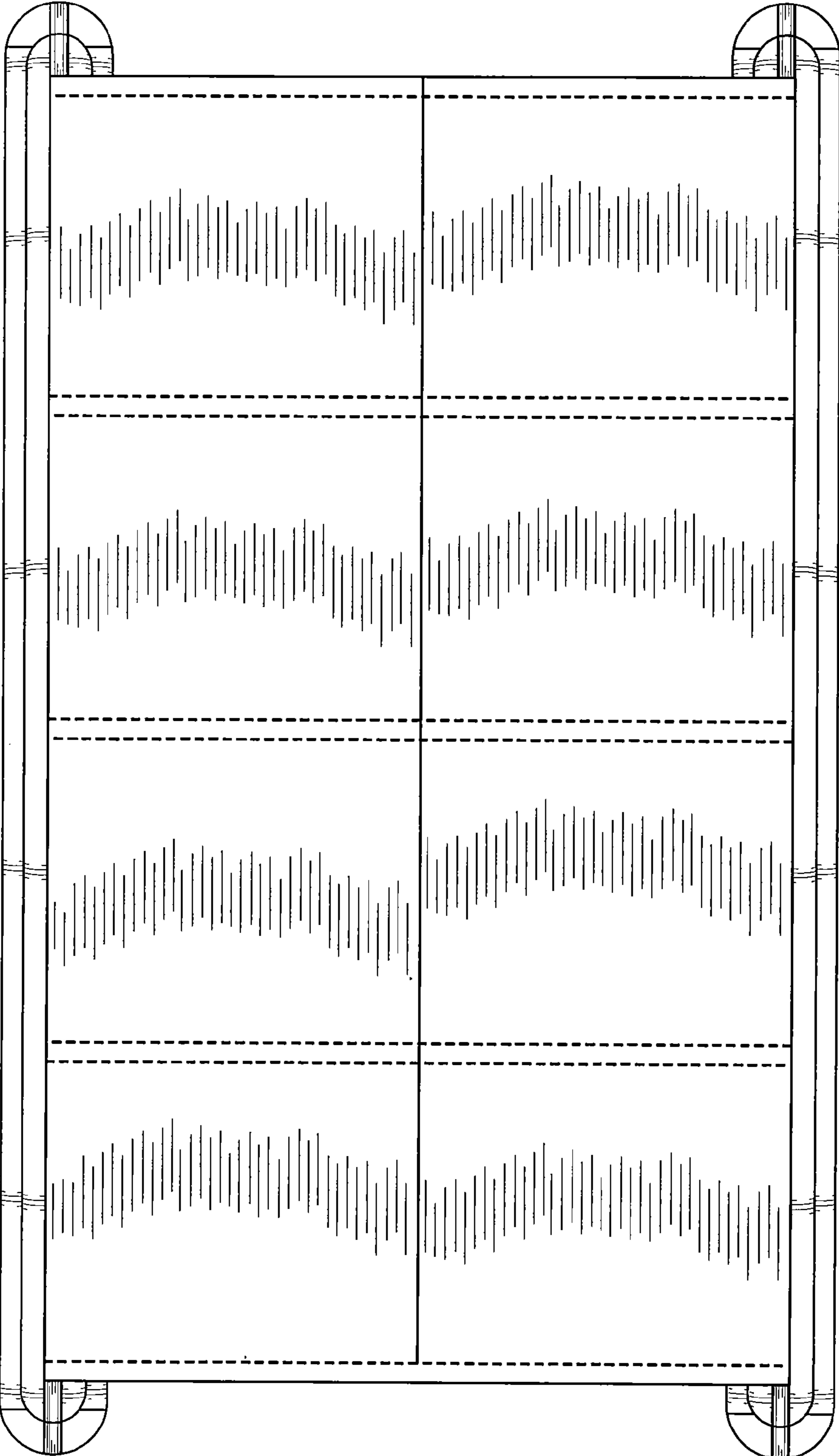

FIG. 4

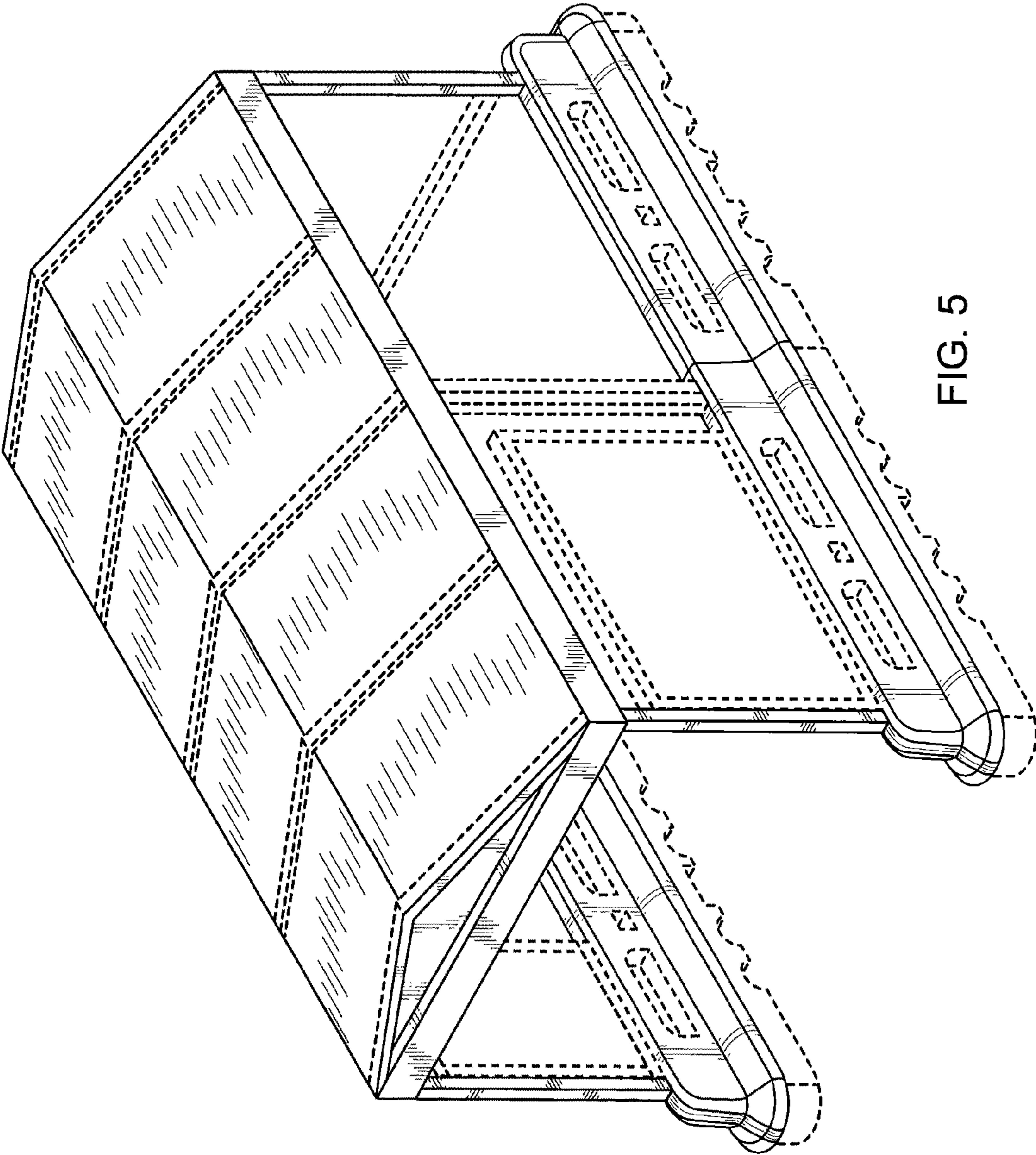

FIG. 5

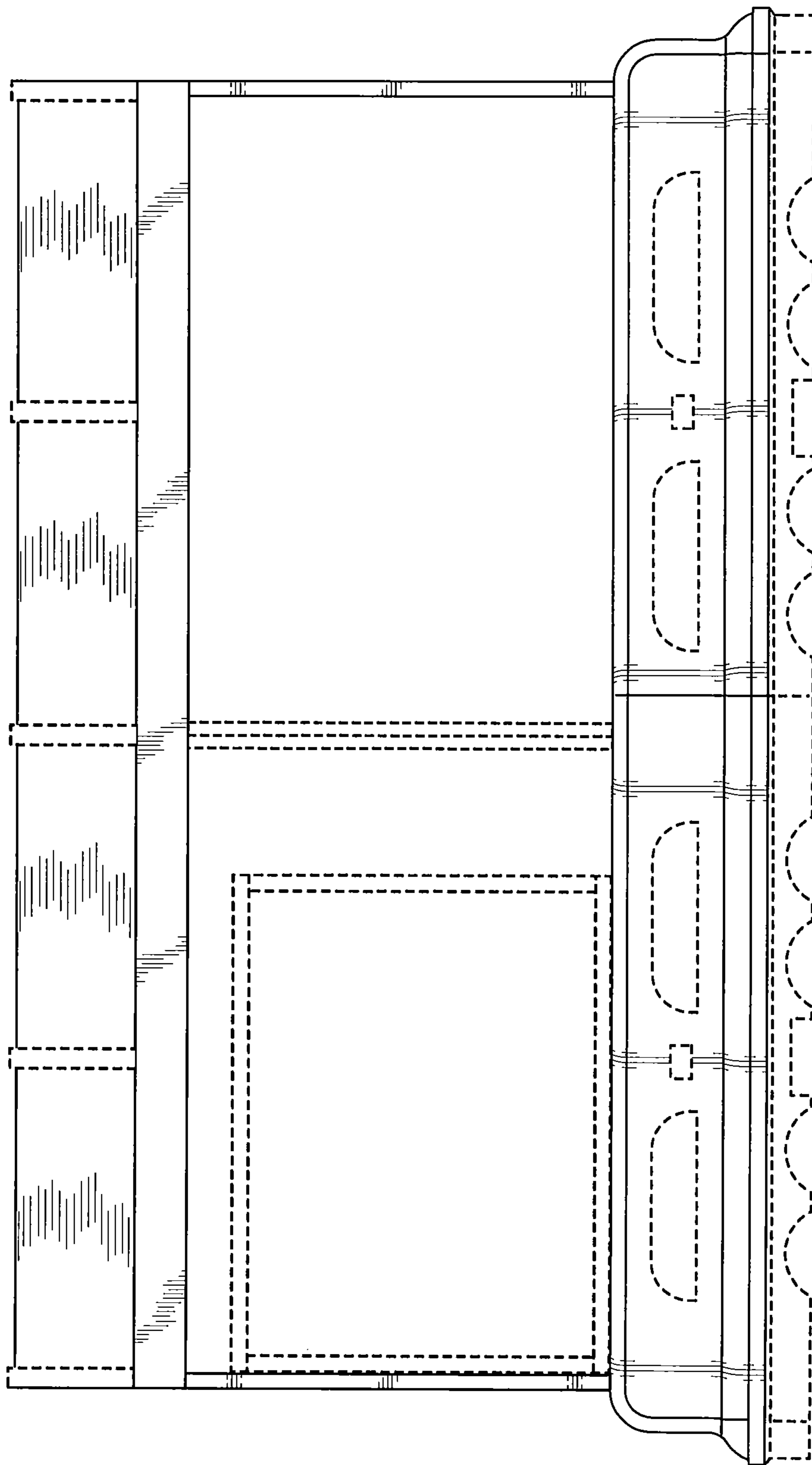

FIG. 6

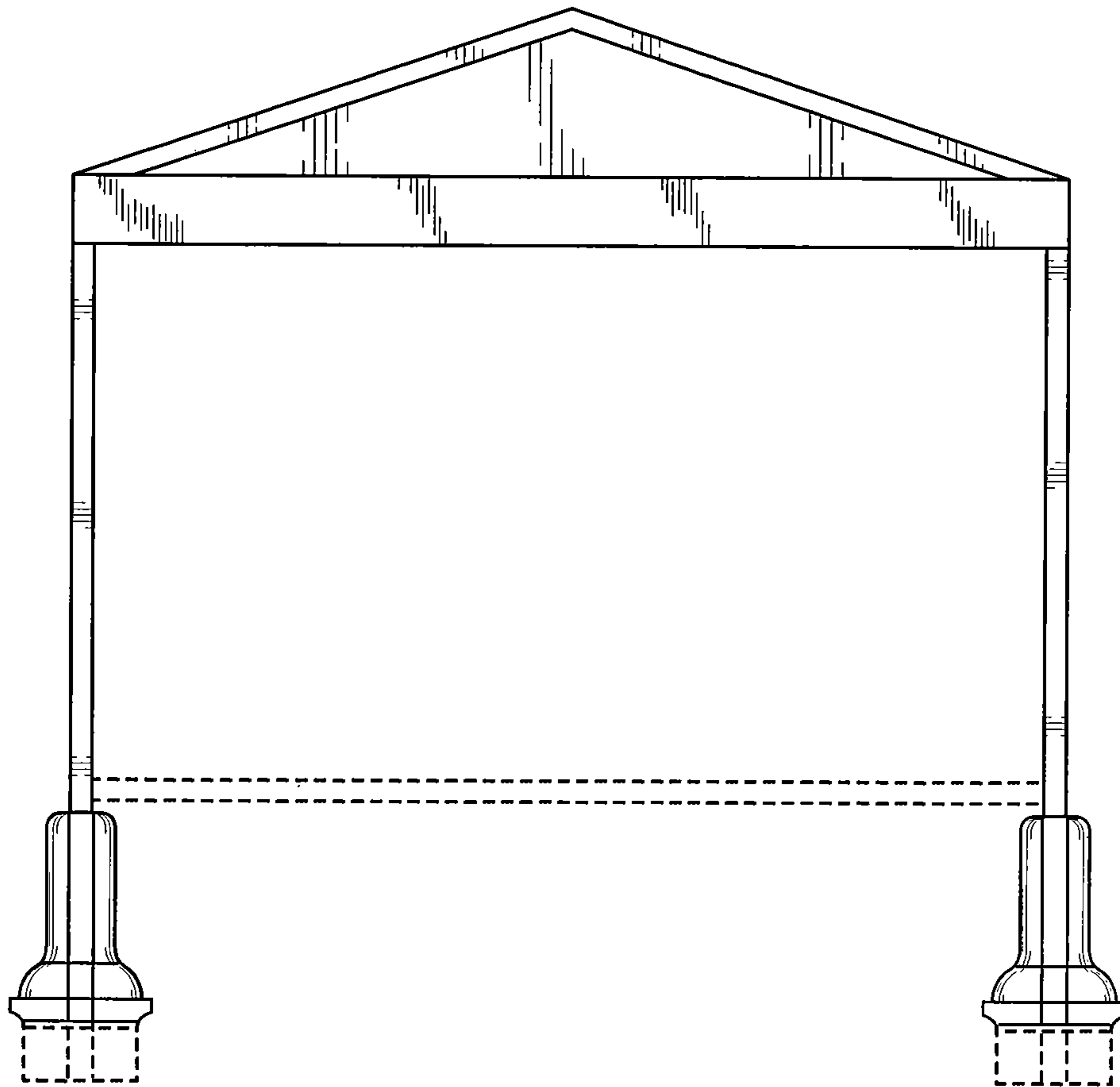

FIG. 7

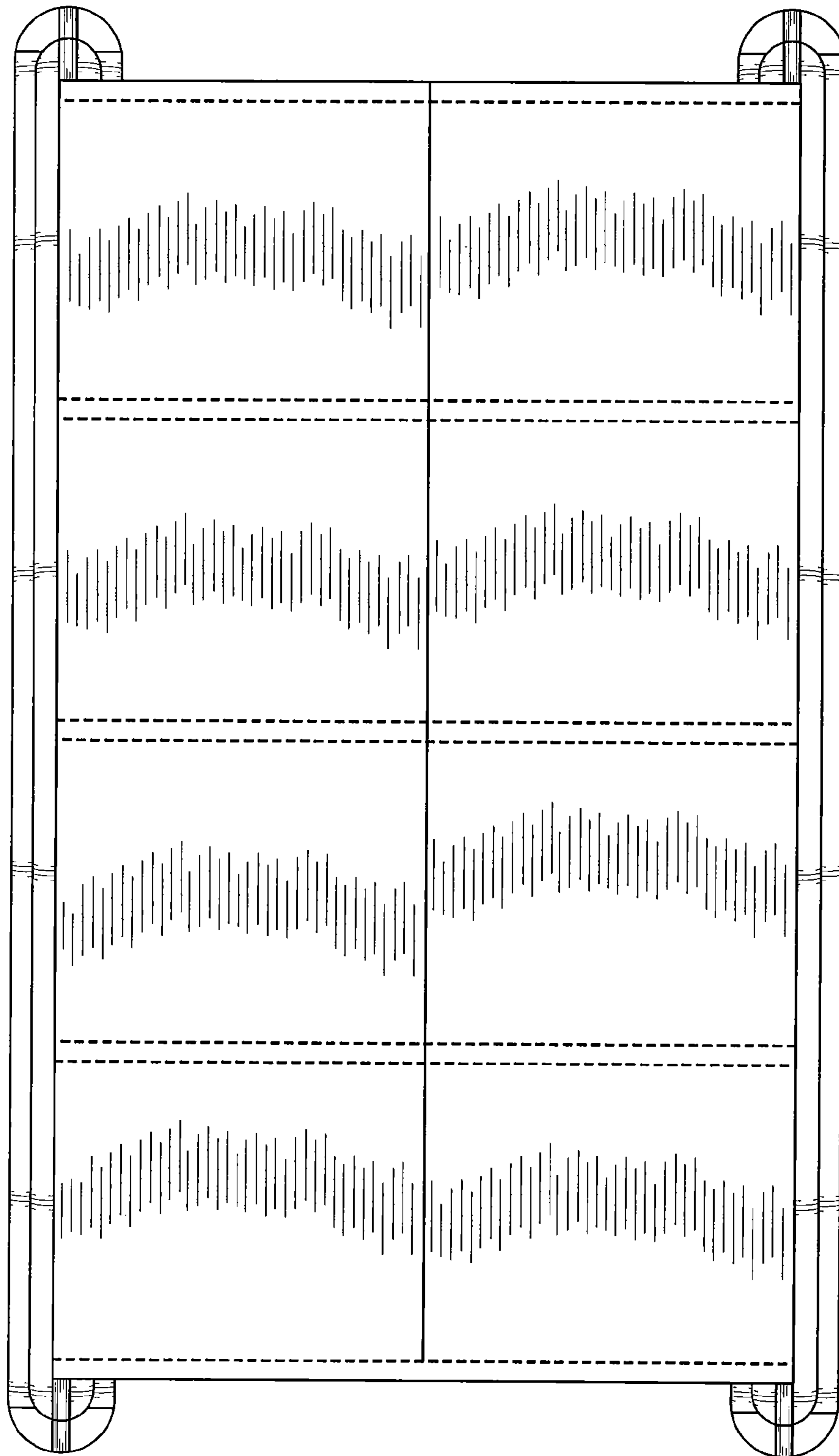

FIG. 8